

# mass integrated

global part distribution • product lifecycle partner  
excess inventory management • value-ad service provider



Data sheet provided by Mass Integrated

[massintegrated.com](http://massintegrated.com) • [displayalliance.com](http://displayalliance.com)

Please call +1.978.465.6190  
Email: [sales@massintegrated.com](mailto:sales@massintegrated.com)



ISO 9001: 2008

Mass Integrated complies with all DMCA takedown notices. Please send a formal DMCA Takedown Notice to Mass Integrated Systems, Inc. • 18 Henry Graf Jr. Road, Unit 1 • Newburyport, MA 01950.



Doc. version :	0.7
Total pages :	32
Date :	Aug. 23, 2004

# Product Specifications

## 2.0" COLOR LTPS TFT-LCD MODULE

MODEL NAME: A020BL01

<◆>Preliminary Specifications

< > Final Specifications

Note: The content of the specifications is subject to change.

© 2004 AU Optonics  
All Rights Reserved,





**Contents:**

<b>A. Physical specifications</b> .....	<b>P2</b>
<b>B. Electrical specifications</b> .....	<b>P3</b>
1. Pin assignment. ....	<b>P3</b>
2. Absolute maximum ratings. ....	<b>P4</b>
3. Electrical characteristics. ....	<b>P5</b>
4. AC Timing.....	<b>P6</b>
5. Serial Control Interface.....	<b>P13</b>
<b>C. Optical specifications</b> .....	<b>P21</b>
<b>D. Reliability test items</b> .....	<b>P22</b>
<b>E. Outline dimension</b> .....	<b>P23</b>
<b>F. Packaging Form</b> .....	<b>P24</b>
<b>G. Application Notes</b> .....	<b>P25</b>

### A. Physical specifications

NO.	Item	Specification	Remark
1	Display resolution(dot)	640(W) × 240(H)	
2	Active area(mm)	40.64(W) × 30.48(H)	
3	Screen size(inch)	2.0 (Diagonal)	
4	Dot pitch(mm)	0.0635(W) × 0.127(H)	
5	Color configuration	R. G. B. delta	
6	Overall dimension(mm)	48.5(W) × 39.8(H) × 3.3(D)	Note 1
7	Weight(g)	20	
8	Panel Surface treatment	Hard coating (3H)	

Note 1: Refer to Fig. 7

## B. Electrical specifications

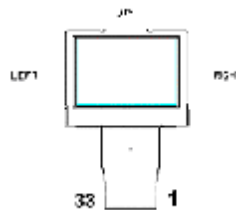
### 1. Pin assignment

Pin no	Symbol	I/O	Description	Remark
1	CS	I	Serial command enable signal	Note 1
2	SDA	I	Serial command data input	Note 1
3	SCL	I	Serial command clock input	Note 1
4	HSYNC	I	Horizontal sync input	
5	VSYNC	I	Vertical sync input	
6	DCLK	I	Input data clock	
7	D7	I	Data input; MSB	
8	D6	I	Data input	
9	D5	I	Data input	
10	D4	I	Data input	
11	D3	I	Data input	
12	D2	I	Data input	
13	D1	I	Data input	
14	D0	I	Data input; LSB	
15	DRV	O	VLED boost transistor driving signal	
16	VLED	P	LED power: anode	
17	FB	I / P	LED power: cathode	
18	AVDD	C	Power setting capacitor	
19	AGND	P	Ground for analog circuit	
20	GND	P	Ground for digital circuit	
21	VCC	P	Power supply for integrated LCD driver IC	
22	V1	C	Power setting capacitor	
23	V2	C	Power setting capacitor	
24	V3	C	Power setting capacitor	
25	V4	C	Power setting capacitor~	

26	V5	C	Power setting capacitor	
27	V6	C	Power setting capacitor	
28	V7	C	Power setting capacitor	
29	V8	C	Power setting capacitor	
30	FRP	O	VCOM driving signal	Note 2
31	VGL	C	Power setting capacitor	
32	VGH	C	Power setting capacitor	
33	VCOM	I	Common voltage	

I: Input; O: Output; P: Power; C: Capacitor.

Note1: For pin sequence arrangement and scan direction, please refer to the figure as below:



Note 2: 3-wire serial control interface is operational after VCC power on reset, but execution of programmed commands is synchronized at front edge of next VSYNC pulse.

Note 3: FRP is the output of Vcom driver. It is the same phase and amplitude with common electrode driving signal (Vcom). The Vcom amplitude and DC level setting can be adjusted through serial control. External Vcom DC adjustment is also achievable. Please refer to the application note for details.

## 2. Absolute maximum ratings

Item	Symbol	Condition	Min.	Max.	Unit	Remark
Power voltage	V <sub>CC</sub>	GND=0	-0.5	5	V	
Operating temperature	T <sub>opa</sub>	-	0	60	°C	Ambient temperature
Storage temperature	T <sub>stg</sub>	-	-25	80	°C	Ambient temperature

### 3. Electrical Specifications

#### a. Recommended operating conditions (GND=AGND=0V)

Item	Symbol	Min.	Typ.	Max.	Unit	Remark	
Power supply	$V_{CC}$	3.0	3.3	3.6	V	Note 1	
Input Signal voltage	H Level	$V_{IH}$	2.4	-	$V_{CC}$	V	
	L Level	$V_{IL}$	GND	-	0.8	V	

Note 1: A build-in power on reset circuit for  $V_{CC}$  is provided within the integrated LCD driver IC. The LCD module is in power save mode in default, and a standby releasing is required after  $V_{CC}$  power on through serial control. Please refer to the register STB setting for detail.

#### b. Electrical Characteristics (GND=AGND=0V)

Parameter	Symbol	Condition	Min.	Typ.	Max.	Unit	Remark
Input Current for $V_{CC}$	$I_{CC}$	$V_{CC}=3.3V$	-	14.5	-	mA	Note 1
	$I_{CC(STANDBY)}$	$V_{CC}=3.3V$	-	0.13	-	mA	
DC-DC voltage	$V_{GH}$	$V_{CC}=3.3V$	8	8.5	9	V	Note 2
	$V_{GL}$	$V_{CC}=3.3V$	-6.5	-6	-5.5	V	Note 2
VCOM voltage	$V_{CAC}$		5.0	5.6	6.4	Vp-p	AC component, Note 3
	$V_{CDC}$		0.7	-	1.5	V	DC component, Note 4
DRV output voltage	$V_{DRV}$		0	-	$V_{CC}$	V	
DRV output current	$I_{DRV}$		-	0.2	10	mA	Note 5
Feedback voltage	$V_{FB}$		0.57	0.6	0.63	V	

Note 1: Test condition: UPS052 mode, DCLK = 27MHz, black pattern. Total power consumption: 47.85mW (typ.)

Note 2:  $V_{GH}$  and  $V_{GL}$  are output voltages of integrated LCD driver IC.

Note 3: The brightness of LCD panel could be adjusted by the adjustment of the AC component of VCOM.

Note 4:  $V_{CDC}$  could be adjusted so as to minimize flicker and maximum contrast on each module.

Note 5:  $I_{DRV}$ (typ.)based on the recommend application circuit

#### c. Recommended Capacitance Values of External Capacitor

The recommended capacitance values of the external capacitor are shown below. These values should be finally determined only after performing sufficient evaluation on the module.

Pin name	Recommended value of capacitors ( $\mu F$ )	Voltage range(V)			Withstanding voltage (V)
		Min	Typ	Max	
AVDD	4.7	5.0	5.5	$2 \cdot V_{CC}$	16 or more
VGH	4.7				16 or more

VGL	4.7		16 or more
V1(+), V2(-)	1	Note1	16 or more
V3(-), V4(+)	1	Note1	16 or more
V5(+), V6(-)	1	Note1	16 or more
V7(-), V8(+)	1	Note1	16 or more

Note 1:V1~V8 are charge pump voltage, no described.

#### d. Backlight driving conditions

Parameter	Symbol	Min.	Typ.	Max.	Unit	Remark
LED current	$I_L$	19.5	20	20.5	mA	
LED voltage	$V_L$	9.6	10.8	12	V	
LED Life Time	$T_L$	10000	-	-	Hr	Note 1,2

Note 1 :  $T_a = 25^\circ\text{C}$ ,  $I_L = 20\text{mA}$

Note 2 : Brightness to be decreased to 50% of the initial value.

## 4. AC Timing

### a. UPS051 timing specifications (refer to Fig. 1, Fig. 2)

Parameter	Symbol	Min.	Typ.	Max.	Unit.	Remark	
DCLK Frequency	$1/t_{\text{DCLK}}$	11.29(*)	13.5	13.59	MHz		
HSYNC	Period	$t_H$	768	858	864	$t_{\text{DCLK}}$	Note 1
	Display period	$t_{\text{hdisp}}$	640			$t_{\text{DCLK}}$	
	Blanking	$t_{\text{hblk}}$	25	30	121	$t_{\text{DCLK}}$	
	Front porch	$t_{\text{hfp}}$	103	188	—	$t_{\text{DCLK}}$	
	Pulse width	$t_{\text{hsw}}$	1	1	$t_{\text{hblk}} - 1$	$t_{\text{DCLK}}$	
VSYNC	Period	$t_V$	245	262.5	265	$t_H$	Note 2
	Display period	$t_{\text{vdisp}}$	240			$t_H$	
	Blanking	$t_{\text{vblk}}$	3	21	31	$t_H$	
	Pulse width	$t_{\text{vsw}}$	1	1	$t_{\text{hblk}} - 1$	$t_{\text{DCLK}}$	
Data set-up time	$t_{\text{ds}}$	12	-	-	ns		
Data hold time	$t_{\text{dh}}$	12	-	-	ns		
Vsync-to-Hsync set-up time	$t_{\text{vhs}}$	1	-	-	$t_{\text{DCLK}}$		

(\*)when  $t_H = 68\mu\text{s}$ ,  $t_V = 245t_H$

Note 1: UPS051 Horizontal blanking time ( $t_{\text{hblk}}$ ) is adjustable by setting register HBLK; requirement of minimum blanking time and minimum front porch time must be satisfied.

Note 2: UPS051 Vertical blanking time ( $t_{\text{vblk}}$ ) is adjustable by setting register VBLK. UPS051 accepts odd-field-only or even-field-only vertical input format.



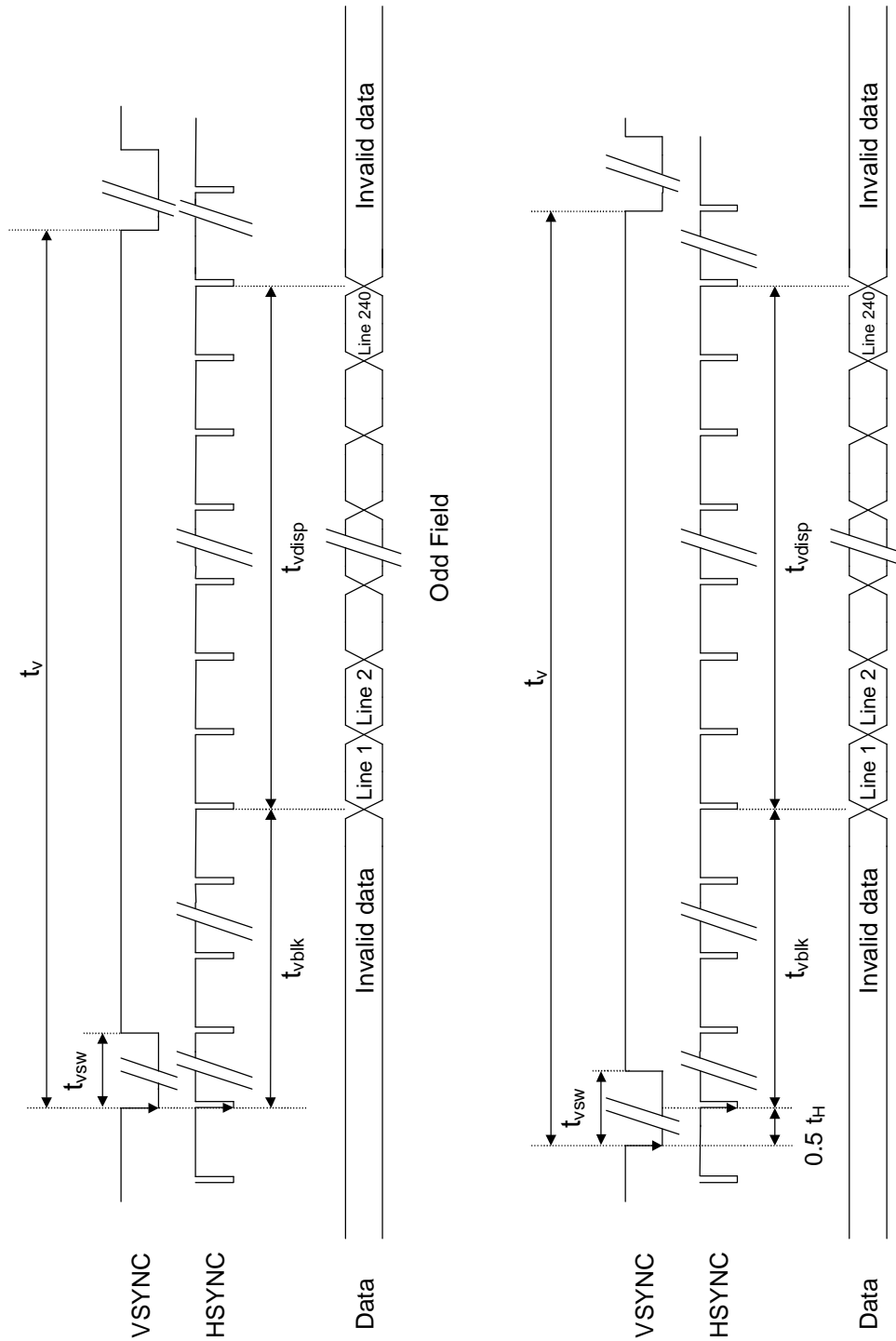


Fig.2 UPS051 Input Vertical Signal

b - 1. UPS052 (320 mode/NTSC/24.545MHz) timing specifications (refer to Fig. 3, Fig. 4)

Parameter		Symbol	Min.	Typ.	Max.	Unit.	Remark
DCLK Frequency		$1/t_{DCLK}$		24.535		MHz	
HSYNC	Period	$t_H$		1560		$t_{DCLK}$	
	Display period	$t_{hdisp}$	1280			$t_{DCLK}$	
	Blanking	$t_{hblk}$	241			$t_{DCLK}$	
	Pulse width	$t_{hsw}$		1		$t_{DCLK}$	
VSYNC	Period	$t_V$		262.5		$t_H$	
	Display period	$t_{vdisp}$	240			$t_H$	
	Blanking	$t_{vblk}$	21			$t_H$	
	Pulse width	$t_{vsw}$		1		$t_{DCLK}$	

b - 2. UPS052 (320 mode/PAL/24.375MHz) timing specifications (refer to Fig. 3, Fig. 4)

Parameter		Symbol	Min.	Typ.	Max.	Unit.	Remark
DCLK Frequency		$1/t_{DCLK}$		24.375		MHz	
HSYNC	Period	$t_H$		1560		$t_{DCLK}$	
	Display period	$t_{hdisp}$	1280			$t_{DCLK}$	
	Blanking	$t_{hblk}$	241			$t_{DCLK}$	
	Pulse width	$t_{hsw}$		1		$t_{DCLK}$	
VSYNC	Period	$t_V$		312.5		$t_H$	
	Display period	$t_{vdisp}$	288			$t_H$	
	Blanking	$t_{vbp}$	24			$t_H$	
	Pulse width	$t_{vsw}$		1		$t_{DCLK}$	

c - 1. UPS052 (352 mode/NTSC/27MHz) timing specifications (refer to Fig. 3, Fig. 4)

Parameter		Symbol	Min.	Typ.	Max.	Unit.	Remark
DCLK Frequency		$1/t_{DCLK}$		27		MHz	
HSYNC	Period	$t_H$		1716		$t_{DCLK}$	
	Display period	$t_{hdisp}$	1408			$t_{DCLK}$	
	Blanking	$t_{hblk}$	241			$t_{DCLK}$	
	Pulse width	$t_{hsw}$		1		$t_{DCLK}$	
VSYNC	Period	$t_V$		262.5		$t_H$	
	Display period	$t_{vdisp}$	240			$t_H$	
	Blanking	$t_{vblk}$	21			$t_H$	
	Pulse width	$t_{vsw}$		1		$t_{DCLK}$	

c - 2. UPS052 (352 mode/PAL/27MHz) timing specifications (refer to Fig. 3, Fig. 4)

Parameter		Symbol	Min.	Typ.	Max.	Unit.	Remark
DCLK Frequency		$1/t_{DCLK}$		27		MHz	
HSYNC	Period	$t_H$		1728		$t_{DCLK}$	
	Display period	$t_{hdisp}$	1408			$t_{DCLK}$	
	Blanking	$t_{hblk}$	241			$t_{DCLK}$	
	Pulse width	$t_{hsw}$		1		$t_{DCLK}$	
VSYNC	Period	$t_V$		312.5		$t_H$	
	Display period	$t_{vdisp}$	288			$t_H$	
	Blanking	$t_{vbp}$	24			$t_H$	
	Pulse width	$t_{vsw}$		1		$t_{DCLK}$	

d - 1. UPS052 (360 mode/NTSC/27MHz) timing specifications (refer to Fig. 3, Fig. 4)

Parameter		Symbol	Min.	Typ.	Max.	Unit.	Remark
DCLK Frequency		$1/t_{DCLK}$		27		MHz	
HSYNC	Period	$t_H$		1716		$t_{DCLK}$	
	Display period	$t_{hdisp}$	1440			$t_{DCLK}$	
	Blanking	$t_{hblk}$	241			$t_{DCLK}$	
	Pulse width	$t_{hsw}$		1		$t_{DCLK}$	
VSYNC	Period	$t_V$		262.5		$t_H$	
	Display period	$t_{vdisp}$	240			$t_H$	
	Blanking	$t_{vblk}$	21			$t_H$	
	Pulse width	$t_{vsw}$		1		$t_{DCLK}$	

d - 2. UPS052 (360 mode/PAL/27MHz) timing specifications (refer to Fig. 3, Fig. 4)

Parameter		Symbol	Min.	Typ.	Max.	Unit.	Remark
DCLK Frequency		$1/t_{DCLK}$		27		MHz	
HSYNC	Period	$t_H$		1728		$t_{DCLK}$	
	Display period	$t_{hdisp}$	1440			$t_{DCLK}$	
	Blanking	$t_{hblk}$	241			$t_{DCLK}$	
	Pulse width	$t_{hsw}$		1		$t_{DCLK}$	
VSYNC	Period	$t_V$		312.5		$t_H$	
	Display period	$t_{vdisp}$	288			$t_H$	
	Blanking	$t_{vbp}$	24			$t_H$	
	Pulse width	$t_{vsw}$		1		$t_{DCLK}$	

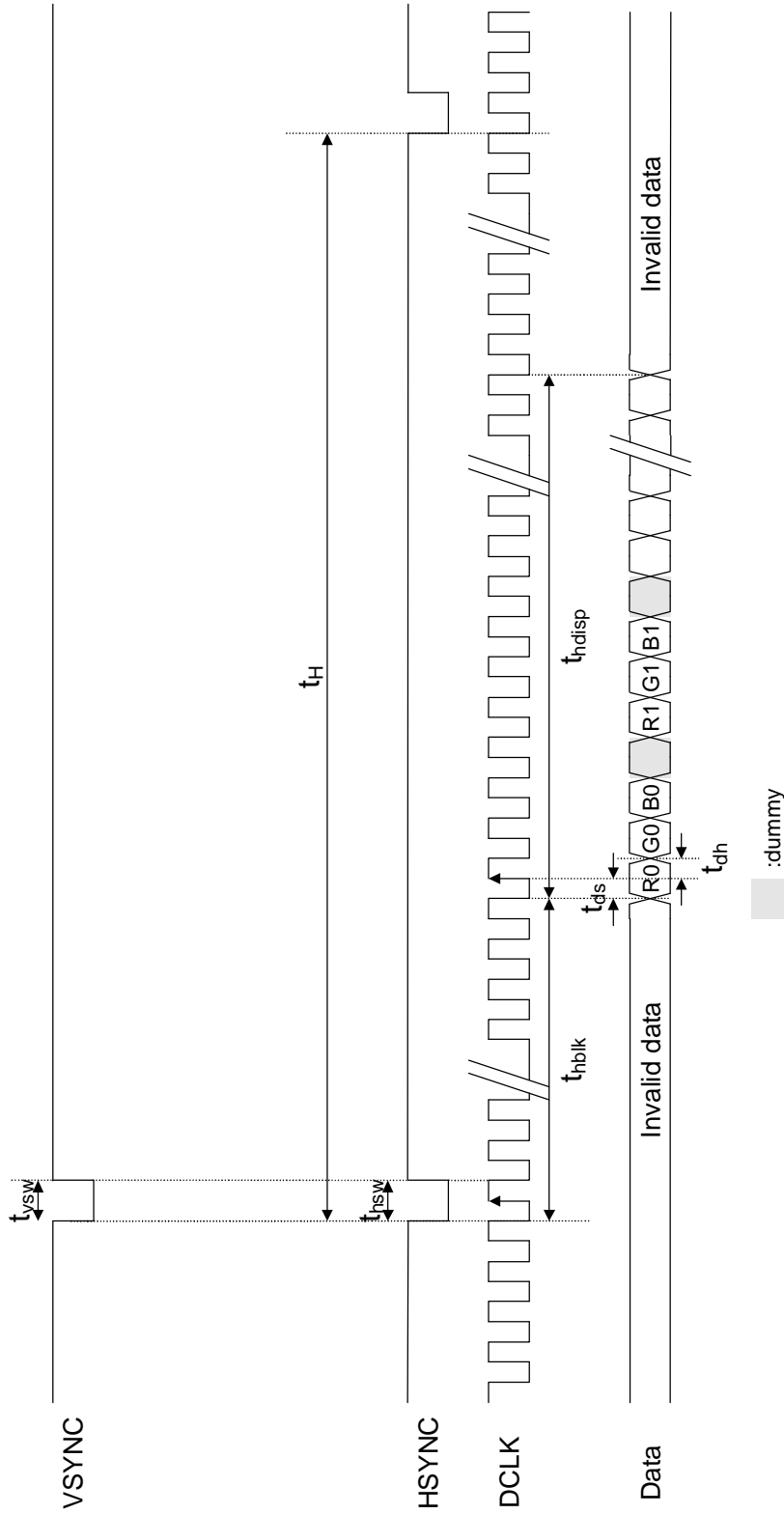
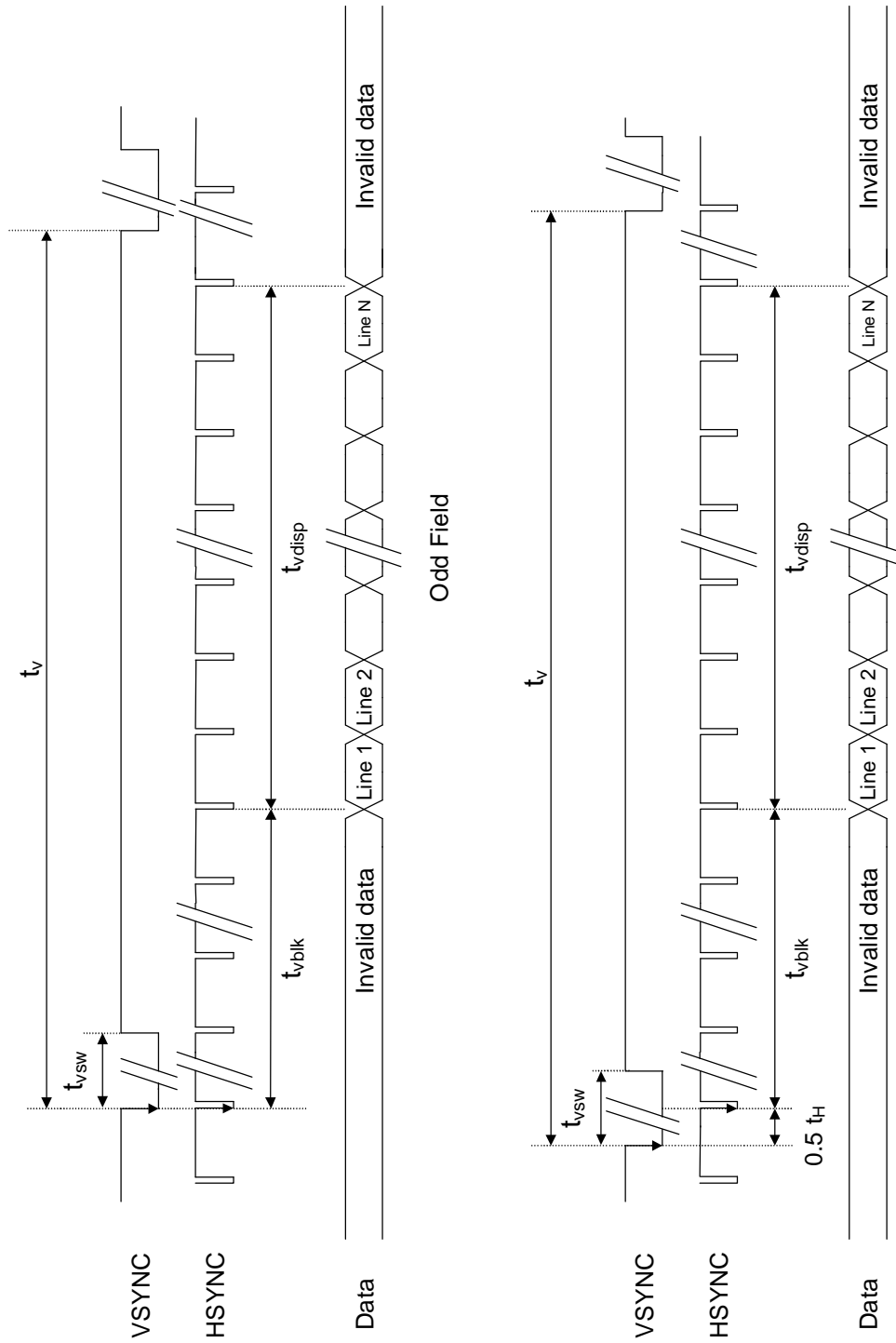


Fig. 3 UPS052 Input Horizontal Signal



**Fig.4 UPS052 Input Vertical Signal**

## 5. Serial Control Interface

### a. Input timing specifications (refer to Fig. 5)

Parameter	Symbol	Min.	Typ.	Max.	Unit.	Remark
Serial load input setup time	$t_{s0}$	150	-	-	ns	
Serial load input hold time	$t_{h0}$	150	-	-	ns	
Serial data input setup time	$t_{s1}$	150	-	-	ns	
Serial data input hold time	$t_{h1}$	150	-	-	ns	
SCL pulse width	$t_{w1L}$	210	-	-	ns	
	$t_{w1H}$	210	-	-	ns	
CS pulse width	$t_{s0W2}$	1	-	-	$\mu$ s	

### b. Serial setting map

No	Test				Register Address				Register Data (Default setting)							
	S15	S14	S13	S12	S11	S10	S9	S8	S7	S6	S5	S4	S3	S2	S1	S0
R0	0	×	×	×	0	0	0	0	×	×	×	×	×	VCOM_AC (011)		
R1	0	×	×	×	0	0	0	1	×	FLK (0)	VCOM_DC (18h)					
R2	0	×	×	×	0	0	1	0	×	×	×	×	CONTRAST (0100)			
R3	0	×	×	×	0	0	1	1	BRIGHT (40h)							
R4	0	×	×	×	0	1	0	0	×	×	SEL (00)	NTSC/PAL (10)		VDIR (1)	HDIR (1)	
R5	0	×	×	×	0	1	0	1	×	GRB (1)	PWMM (1)	PWM_DUTY (10)	SHDB2 (1)	SHDB1 (1)	STB (0)	
R6	0	×	×	×	0	1	1	0	×	×	×	VBLK (15h)				
R7	0	×	×	×	0	1	1	1	HBLK (1Eh)							
R8	0	×	×	×	1	0	0	0	×	×	×	×	×	PSL (000)		

× : Dummy bit

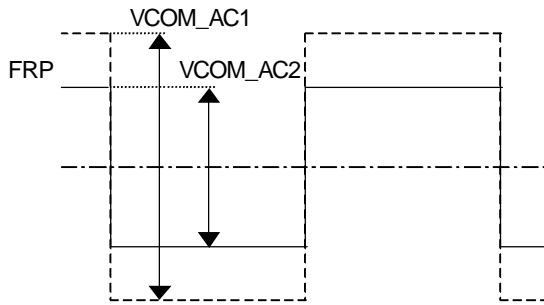
### c. Description of Serial Control Operations

- I Each serial command consists of 16 bits of data which is loaded one bit a time at the rising edge of serial clock SCL
- I Command loading operation starts from the falling edge of CS and is completed at the next rising edge
- I The serial control block is operational after power on reset, but commands are established by the VSYNC signal. If command is transferred multiple times for the same register, the last command before the VSYNC signal is valid. Please refer to Fig. 6.
- I If less than 16 bits of SCL are input while CS is low, the transferred data is ignored.
- I If 16 bits or more of SCL are input while CS is low, the first 16 bits of transferred data before the rising edge of CS pulse are valid data.
- I Serial block operates with the SCL clock and serial data can be accepted in the power save mode

d. Description of serial control data

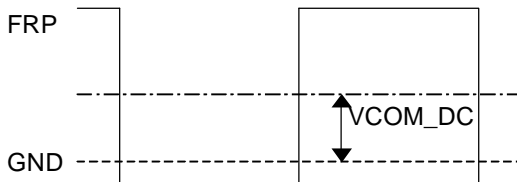
(1) VCOM\_AC: Common voltage AC level selection; 3 bit setting, 0.2V / LSB (deviation  $\pm 4\%$ )

(MSB – LSB)	VCOM AC LEVEL	UNIT
000	5.0	V
001	5.2	
010	5.4	
011	5.6 (Default)	
100	5.8	
101	6.0	
110	6.2	
111	6.4	



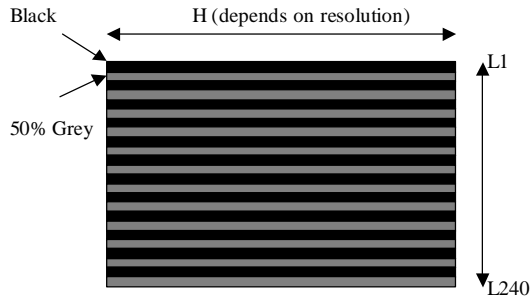
(2) VCOM\_DC : Common voltage DC level selection; 6 bit setting

(MSB – LSB)	VCOM AC LEVEL	UNIT
00h	1.75	V
18h	1.1(Default)	
3Fh	0	



(3) FLK : flicker pattern output

FLK	Function
0	Normal operation (Default)
1	Flicker pattern output



(4) CONTRAST : RGB contrast level setting; 4-bit setting

(MSB-LSB)	Function
0000	Low contrast
0100	Center (Default)
1111	High contrast

(5) BRIGHTNESS : RGB bright level setting; 8-bit setting

(MSB-LSB)	Function
00h	Dark
40h	Center (Default)
FFh	Bright

(6) HDIR : Horizontal scan direction setting

HDIR	Function
0	Right-to-left scan
1	Left-to-right scan (Default)

(7) VDIR : Vertical scan direction setting

VDIR	Function
0	Down-to-up scan
1	Up-to-down scan (Default)

(8) NTSC/PAL : NTSC or PAL mode selection (for UPS052 input timing)

(MSB-LSB)	Function
00	PAL mode
01	NTSC mode
10	Auto-detection mode (Default)
11	

(9) SEL : Input data timing format selection; please refer to AC timing section for detail specifications.

(MSB-LSB)	Input Timing Format
00	UPS051 (Default)
01	UPS052: 320x240
10	UPS052: 352x240
11	UPS052: 360x240

(10) STB : Standby ( power saving ) mode setting

STB	Function
0	Standby mode (Default)
1	Normal operation

(11) SHDB1: Shut-down of the power boost converter for LED backlight unit

SHDB1	Function
0	The LED power converter is off
1	The LED power converter is controlled by build-in on/off sequence (Default)

(12) SHDB2: Shut-down for VGH/VGL charge pump

SHDB2	Function
0	The VGH/VGL charge pump is off
1	The VGH/VGL charge pump is controlled by build-in on/off sequence (Default)

(13) PWM\_DUTY: PWM duty cycle selection for LED backlight power converter ( valid when PWMM = 0 )

(MSB-LSB)	PWM duty cycle
00	50%
01	60%
10	65% (Default)
11	70%

(14) PWMM: PWM mode selection

PWMM	Function
0	Mode 0: fixed duty cycle
1	Mode 1: increasing duty cycle (Default)

(15) GRB: Register reset setting

GRB	Function
0	Reset all registers to default values
1	Normal operation (Default)

(16) VBLK: Vertical blanking setting for UPS051; 5-bit setting, 1 line/LSB

(MSB-LSB)	V-blanking $t_{vblk}$	UNIT
00h	0	line
15h	21 (Default)	
1Fh	31	

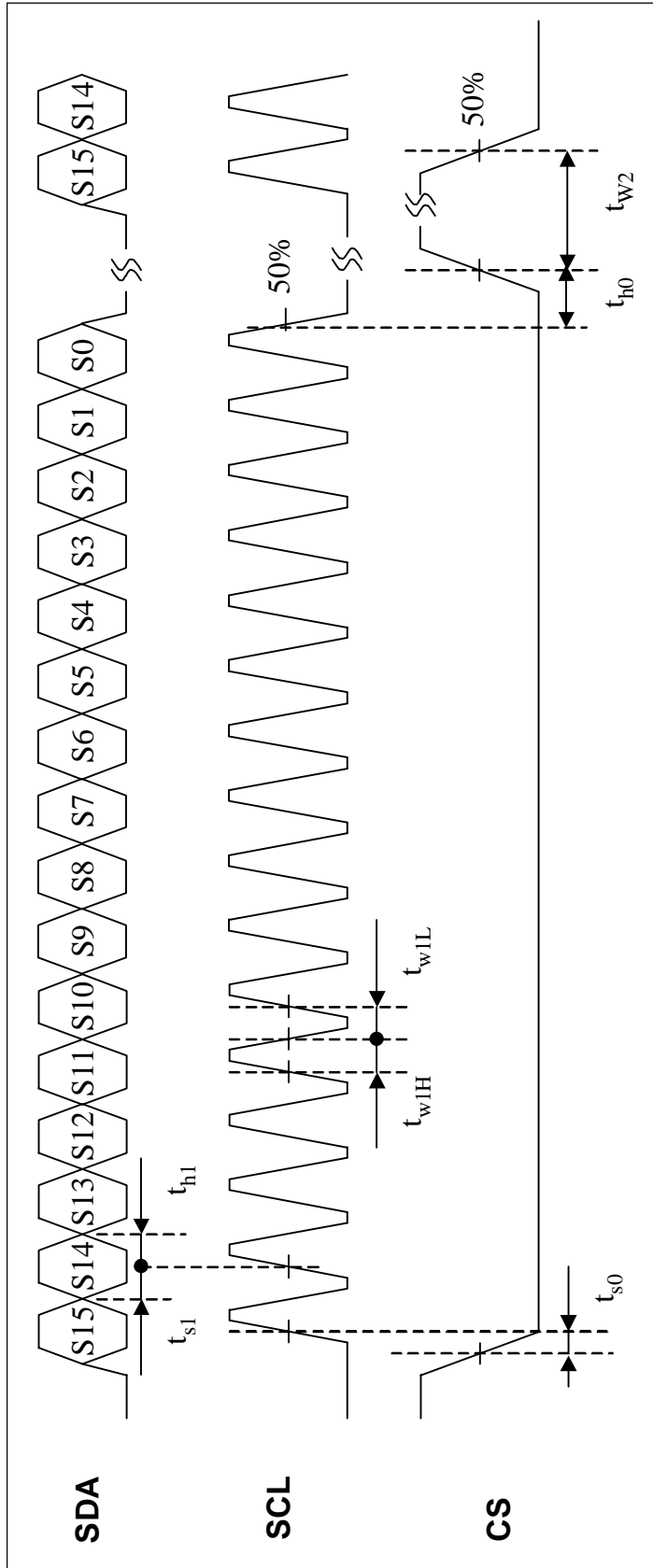
(17) HBLK: Horizontal blanking setting for UPS051; 8-bit setting, 1 DCLK/LSB

(MSB-LSB)	H-blanking $t_{hblk}$	UNIT
00h	0	DCLK
1Eh	30 (Default)	
FFh	255	

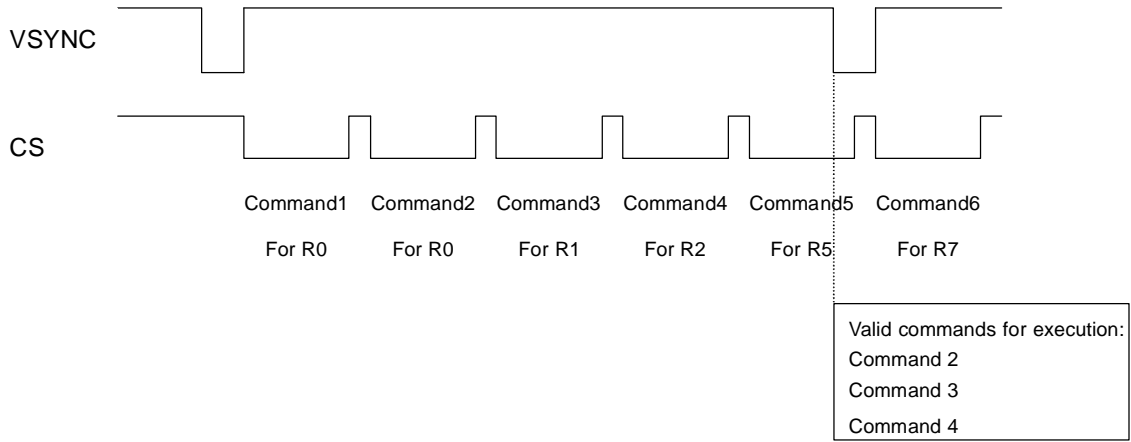
(18) PSL : Panel resolution selection

(MSB-LSB)	Function
0XX	Controlled by driver IC input pins : PSL0, PSL1 (Default)
100	502 * 240 (dots)
101	640 * 240 (dots)
110	720 * 240 (dots)
111	960 * 240 (dots)

Note : "X" is "0" or "1"



**Fig. 5 Serial Control Timing**



**Fig. 6 Example of Serial Command Operation**

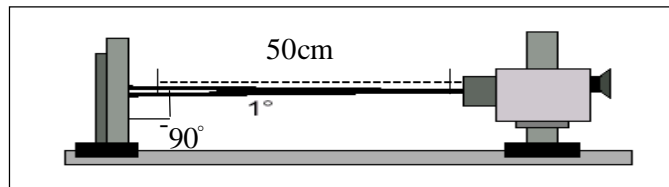
**C. Optical specifications (Note 1,Note 2, Note 3 )**

Item	Symbol	Condition	Min.	Typ.	Max.	Unit	Remark
Response time	Rise	$\theta = 0^\circ$	-	15	25	ms	Note 4
	Fall		-	20	30	ms	
Contrast ratio	CR	At optimized viewing angle	120	200	-		Note 5,6
Viewing angle	Top	$CR \geq 10$	10	-	-	deg.	Note 7
	Bottom		30	-	-		
	Left		40	-	-		
	Right		40	-	-		
Brightness	$Y_L$	$\theta = 0^\circ$	200	240	-	nits	Note 8
White chromaticity	X	$\theta = 0^\circ$	0.27	0.31	0.35		
	y	$\theta = 0^\circ$	0.29	0.35	0.40		
Luminance Uniformity			60			%	Note 9

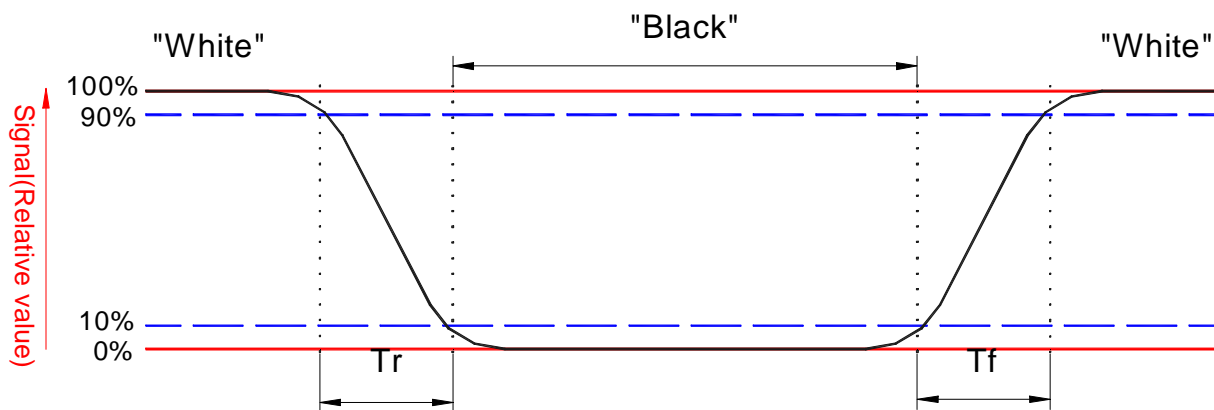
Note 1. Ambient temperature =25°C. And backlight current  $I_L=20$  mA

Note 2. To be measured in the dark room.

Note 3. To be measured on the center area of panel with a field angle of 1° by Topcon luminance meter BM-7, after 10 minutes operation, distance:500±50mm.



Note 4. Definition of response time: The output signals of photo detector are measured when the input signals are changed from “black” to “white”(falling time) and from “white” to “black”(rising time), respectively. The response time is defined as the time interval between the 10% and 90% of amplitudes. Refer to figure as below.



Note 5. Definition of contrast ratio:

Contrast ratio is calculated with the following formula.

$$\text{Contrast ratio (CR)} = \frac{\text{Photo detector output when LCD is at "White" state}}{\text{Photo detector output when LCD is at "Black" state}}$$

Note 6. White  $V_i = V_{i50} \pm 1.5V$

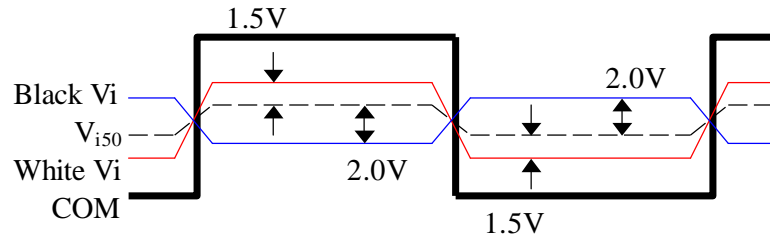
Black  $V_i = V_{i50} + 2.0V$

"±" Means that the analog input signal swings in phase with COM signal.

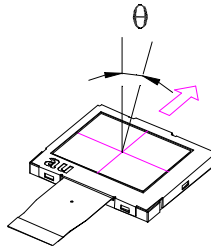
"+" Means that the analog input signal swings out of phase with COM signal.

$V_{i50}$ : The analog input voltage when transmission is 50%

The 100% transmission is defined as the transmission of LCD panel when all the input terminals of module are electrically opened.

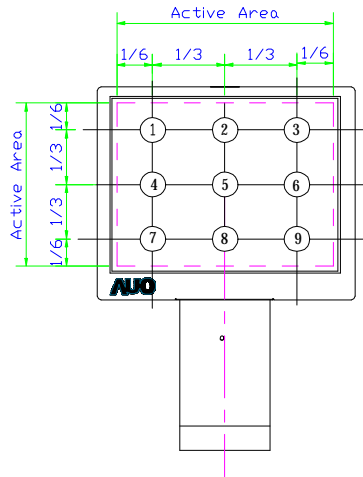


Note 7. Definition of viewing angle:



Note 8. Measured at the center area of the panel when all the input terminals of LCD panel are electrically opened.

Note 9: Definition of luminance uniformity

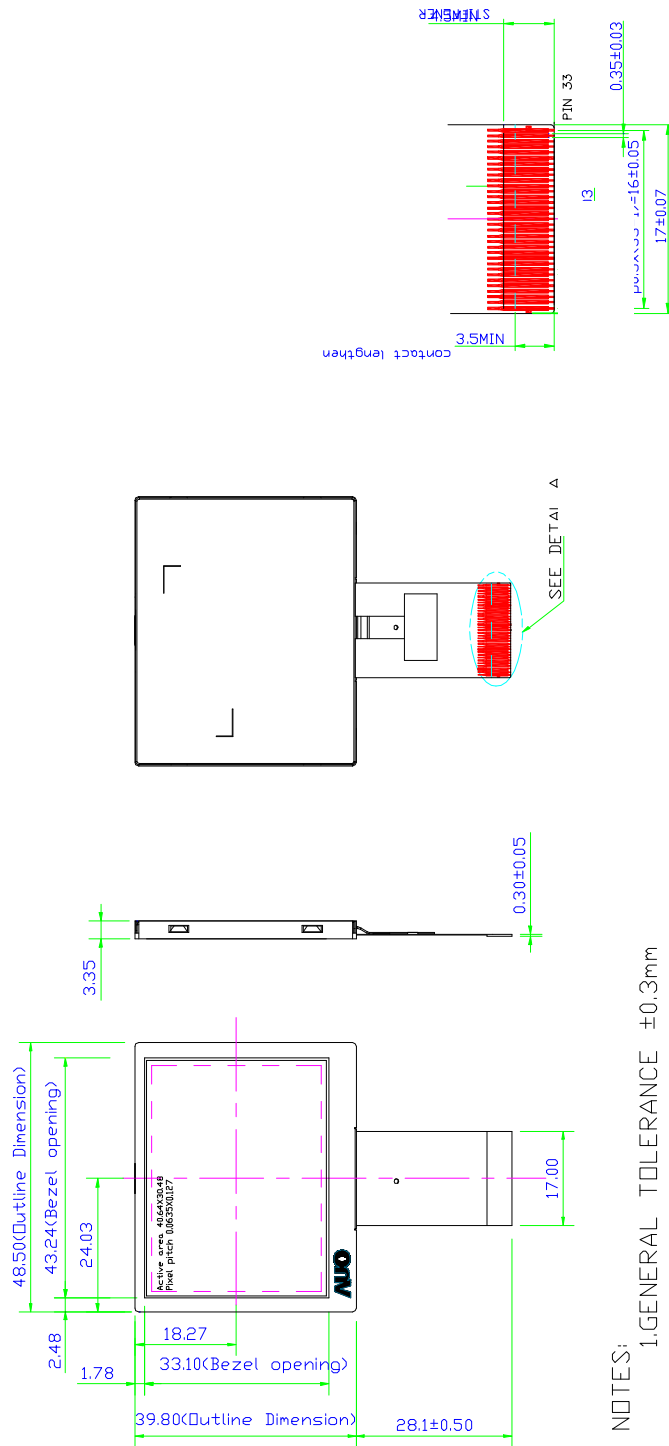


**D. Reliability test items:**

No.	Test items	Conditions	Remark
1	High temperature storage	Ta= 80°C                      240Hrs	
2	Low temperature storage	Ta= -25°C                      240Hrs	
3	High temperature operation	Ta= 60°C                      240Hrs	
4	Low temperature operation	Ta= 0°C                      240Hrs	
5	High temperature and high humidity	Ta= 60°C . 90% RH              240Hrs	Operation
6	Heat shock	-25°C~80°C/50 cycle 2Hrs/cycle	Non-operation
7	Electrostatic discharge	±200V,200pF(0Ω), once for each terminal	Non-operation
8	Vibration	Frequency range : 10~55Hz Stoke : 1.5mm Sweep : 10~55Hz~10Hz 2 hours for each direction of X,Y,Z (6 hours for total)	Non-operation JIS C7021, A-10 condition A
9	Mechanical shock	100G . 6ms, ±X,±Y,±Z 3 times for each direction	Non-operation JIS C7021, A-7 condition C
10	Vibration (with carton)	Random vibration: 0.015G <sup>2</sup> /Hz from 5~200Hz -6dB/Octave from 200~500Hz	IEC 68-34
11	Drop (with carton)	Height: 60cm 1 corner, 3 edges, 6 surfaces	

Note: Ta: Ambient temperature.

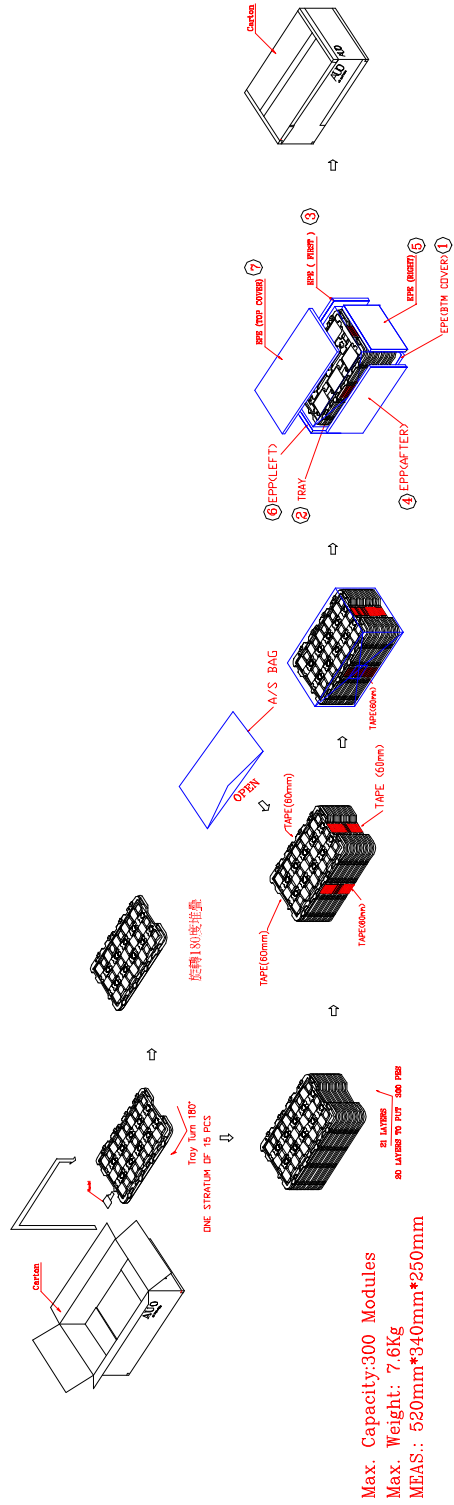
E. Outline dimension



NOTES:  
 1.GENERAL TOLERANCE ±0.3mm

Fig.7 Outline dimension of TFT-LCD module

F. Packing form



## G. Application Notes

This LTPS TFT LCD module is designed for digital still camera application. A COG type LCD driver IC is integrated within this module, makes it much easier to design and cost-effective. The main features of integrated driver are:

- I Accepting digital serial R, G, B 8-bit signal, fewer adjustment, fewer design effort, and lower power consumption compared to other analog LTPS solution.
- I Integrated timing controller for UPS051 and UPS052 input timing formats. For UPS052 input timing, the input signal is always the same for different panel resolution.
- I Integrated LED power converter controller, DC-DC charge pump, and Vcom driver. A design requires less peripheral components and reduces the total system cost.

### 1. Input Data Timing

Two kinds of input timing format are supported: UPS051 and UPS052. In UPS051 input format, the conversion of image data to display dots is controled by the user. In UPS052 input format, the mapping of incoming data to display dots is take cared by built in scaling function of driver IC.

For UPS051 timing, the module accpet one dot video data at the rising edge of DCLK, and display them one dot by one dot. Therefore the input data timing is different according to different panel resolutions and scan directions. Refer to the AC Timing of UPS051 part, you can use the typ. value for a typical case, or you can use the min. value to lower down the power consumption and EMI.

Because of delta color filter arrangement, the RGB data sequence for even and odd lines are different based on scan direction. For the definition of even and odd lines, see Fig. 8.

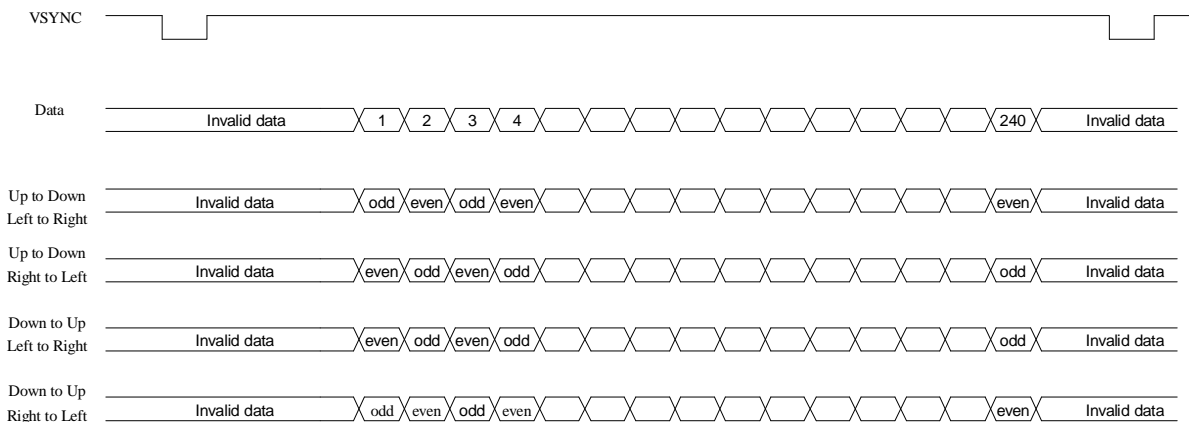


Fig 8. UPS051 even and odd lines definition

For the RGB sequence, see Fig. 9.

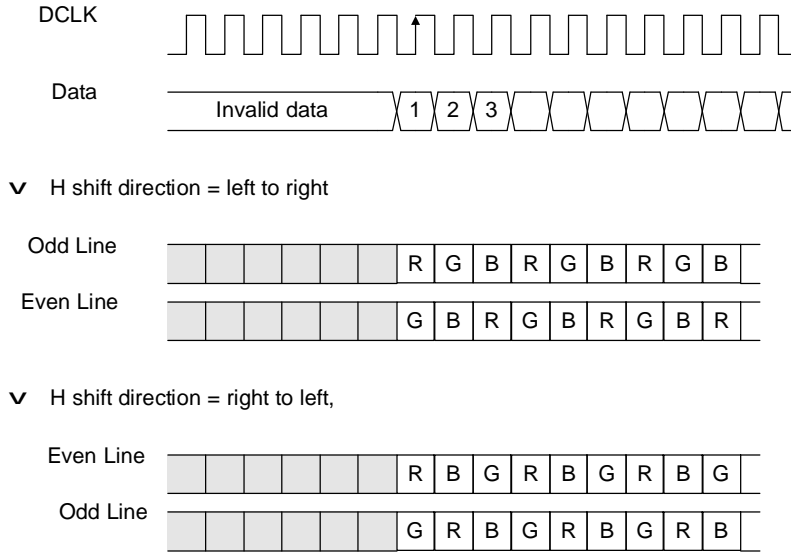


Fig. 9 UPS051 Input RGB sequence

For the color filter arrangement, see Fig. 10.

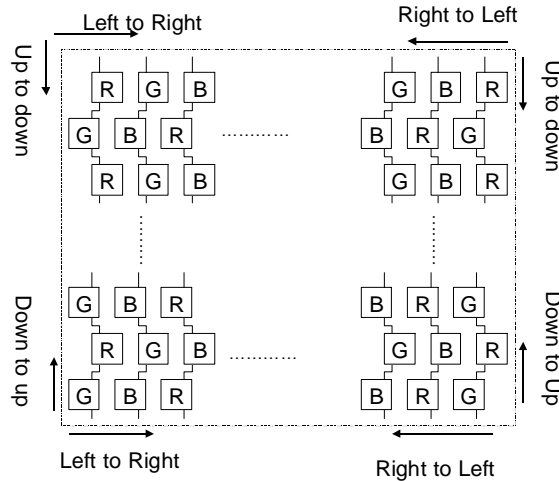


Fig. 10 Color filter arrangement

For UPS052 timing, there are three input RGB data modes to choose from: 320xRGB, 352xRGB, and 360xRGB. Input data is processed and mapped to display dots by integrated driver IC according to panel resolution and scan direction settings. UPS052 input format saves the effort of data scaling for users and keeps a consistent interface for different display resolutions, in the cost of higher input data rate and less image processing elasticity. An additional NTSC/PAL auto-detection function is provided for UPS052 input format. When the function is active, the HSYNC and VSYNC inputs are monitored. If there are more than

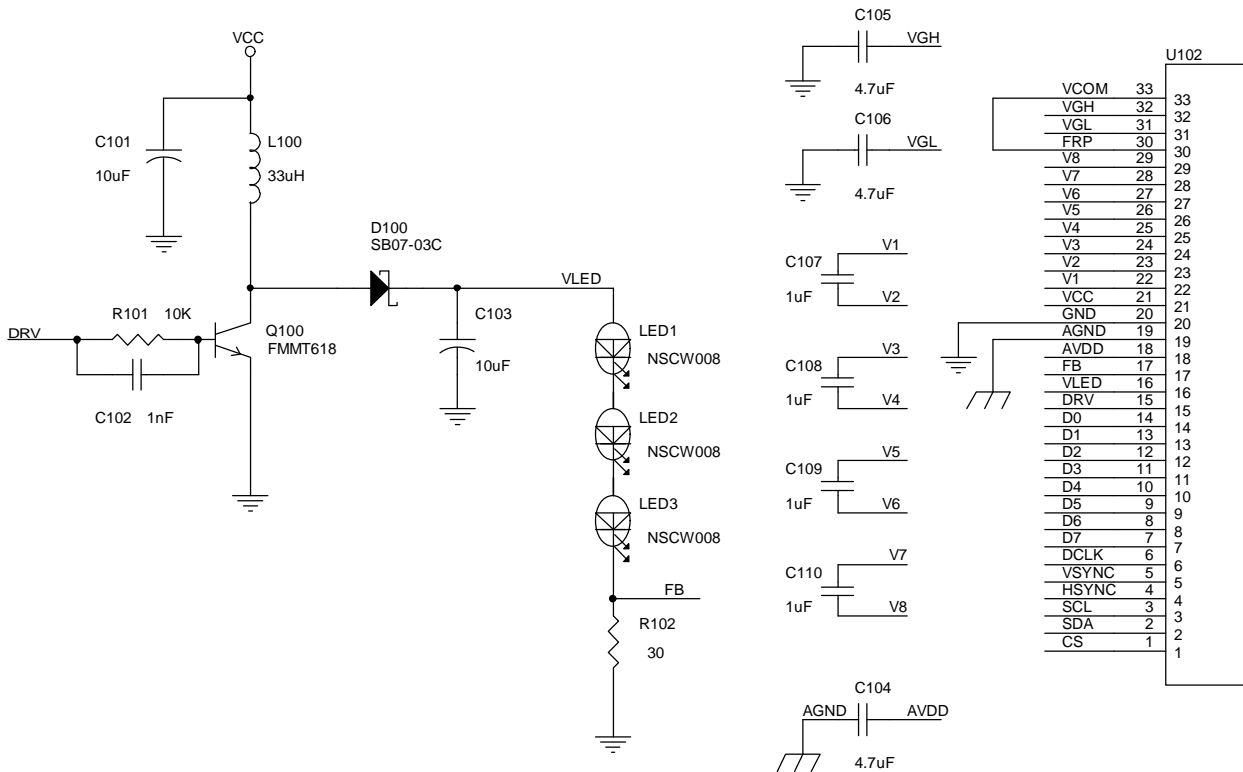
288 HSYNC in a VSYNC period, it is detected as the PAL mode (288 active lines). On the other hand, if there are less than 288 HSYNC in a VSYNC period, it is asserted as the NTSC mode (240 active lines). Please refer to the serial control setting for more details.

For vertical input timing, both UPS051 and UPS052 accept odd / even field switching or single field only input. For detail timing spec., please refer to Fig 2 and Fig 4.

## 2. Typical Application Circuit

### 2-1. Internal LED booster circuit

The integrated driver IC provides build-in LED booster controller, DC-DC charge pump, and Vcom driver. See Fig. 11 for the application circuit.



**Fig.11 Internal LED boost Circuit**

A single 3.3V power supply (VCC) is required to provide driver IC power and generate all necessary voltages for LCD related circuits.

According to Fig. 11, the L100, Q100, D100, and C103 together form the LED boost converter. The converter with 0.6V feedback (FB) and R102 provide a constant 20mA current for LED backlight unit. The boost converter switching signal DRV is generated based on divided frequency of DCLK. Therefore the DCLK input is required for LED driver operation, and the absent of DCLK signal during normal operation will set the driver IC into standby mode. A low ESR capacitor for C103 is recommended in order to reduce voltage ripple of

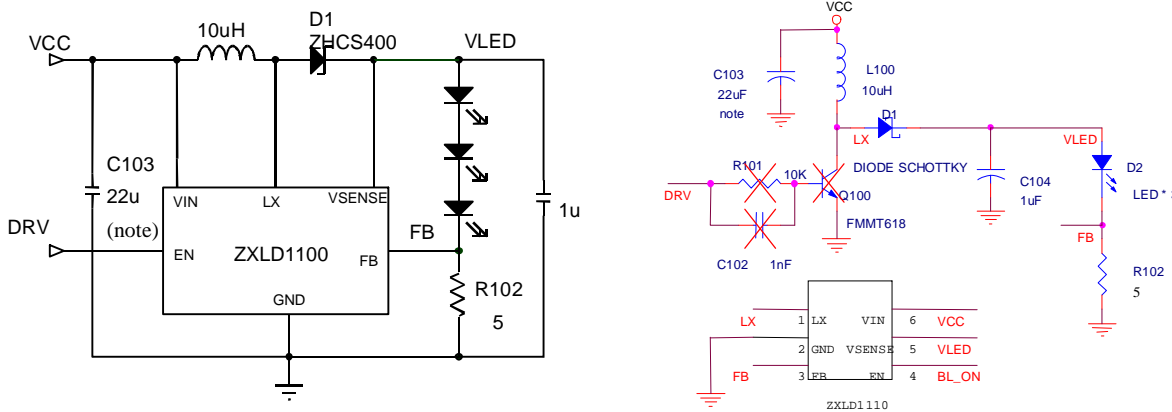
VLED. The build-in LED boost controller is default active, and it is able to be turned off by setting the register SHDB1 to low.

The positive (VGH) and negative (VGL) power supplies for LCD are generated through build-in DC-DC charge pump circuit, an elegant design with only seven passive power-setting capacitors are required.

The LED booster circuit may cause the wave like phenomenon, In order to reduce the phenomenon ,AGND and DGND (system GND) and LED booster circuit GND must be separated.If the phenomenon is still seriously observed,use external LED driver circuit is the other way.

### 2-2. External LED driver circuit

Using external LED driver circuit is the best way to reduce the wave like phenomenon, Adopting external LED driver circuit is recommended , See Fig. 12 for the application circuit.



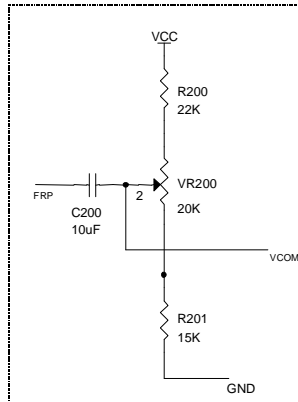
**Fig.12 External LED driver Circuit**

single 3.3V power supply (VCC) is required to provide driver IC power and generate all necessary voltages for LCD related circuits.

According to Fig. 12,the LED driver(ZXLD1100) and R102(5 ohm) with 0.2V feedback (FB) can provide a constant 20mA current for LED backlight unit.To control the back light on/off timing,user should create a control signal BL\_ON(please refer to the ZXLD1100 date sheet). The LCD driver output DRV signal can also be used to drive BL\_ON, in the condition of fine tune the R102 value to get the desired LED current value.

Note:C103 use TAIYO 22uF 1210 type X5R +-20% 6.3VDC

The build-in VCOM driver provides programmable amplitude and DC-level adjustments through serial control interface to optimize image contrast and minimize flicker. Optional external VCOM DC-level adjustment is achievable through external DC bias setting of FRP output (pin30) and VCOM input (pin33). The Fig. 13 is a simple external VCOM DC bias circuit for reference.



**Fig.13 VCOM-DC External Adjustment Circuit**

### 3. Power ON/OFF Sequence

The register setting of standby mode disabling / enabling is used to control the build-in power on / off sequence.

#### 3-1 Power On (Standby Disabling)

After VCC power on reset, VSYNC/HSYNC/DCLK/DATA can be input, and serial control interface is also operational. The LCD driver is in default standby mode after VCC power-on, and **setting register #5 bit #0 to high (STB=1)** to disable the standby mode is required for normal operation. When the standby mode is disabled, a build-in power on sequence is started. The driver IC analog power AVDD is turned on first, and then the LCD positive and negative power supplies VGH/VGL are pumped, and followed by the backlight LED power VLED. Please refer to Fig.14 for the detail timing of power on/off sequence.

Since the LCD driver supports different panel resolutions, setting of output resolution is essential for proper LCD operation. The setting of output resolution is through register "PSL". For 2-inch 640x240 LCD: PSL[2:0] = 101. It is recommended to program essential serial commands first before releasing the LCD module from default standby mode. Please refer to Fig. 15 for recommend serial settings.

**After power on or standby mode disabling, a vertical / horizontal scan direction flipping is required to initializing the bi-direction control circuit of gate driver and data driver. A power on failure might happen, if the LCD is power on without proper scan direction initiation. Please refer to Fig.15 for recommend serial settings.**

### 3-2 Power Off (Standby Enabling)

When the register #5 bit #0 is set to low (STB=0) to enable standby mode, a build-in power off sequence is started. Please refer to Fig.14 for the detail timing. No serial command programming is allowed right after standby mode is enabled, for a time period of minimum 7 fields (1 field: NTSC=16.6msec / PAL=20msec).

### 3-3 Clock Stop Reset

The DCLK signal is required for normal operation. When the DCLK is stopped for more than 5.6 $\mu$ sec (or DCLK frequency < 140KHz) during normal operation, the driver IC will be reset and operated in standby mode. This DCLK stop reset does not affect the serial interface settings.

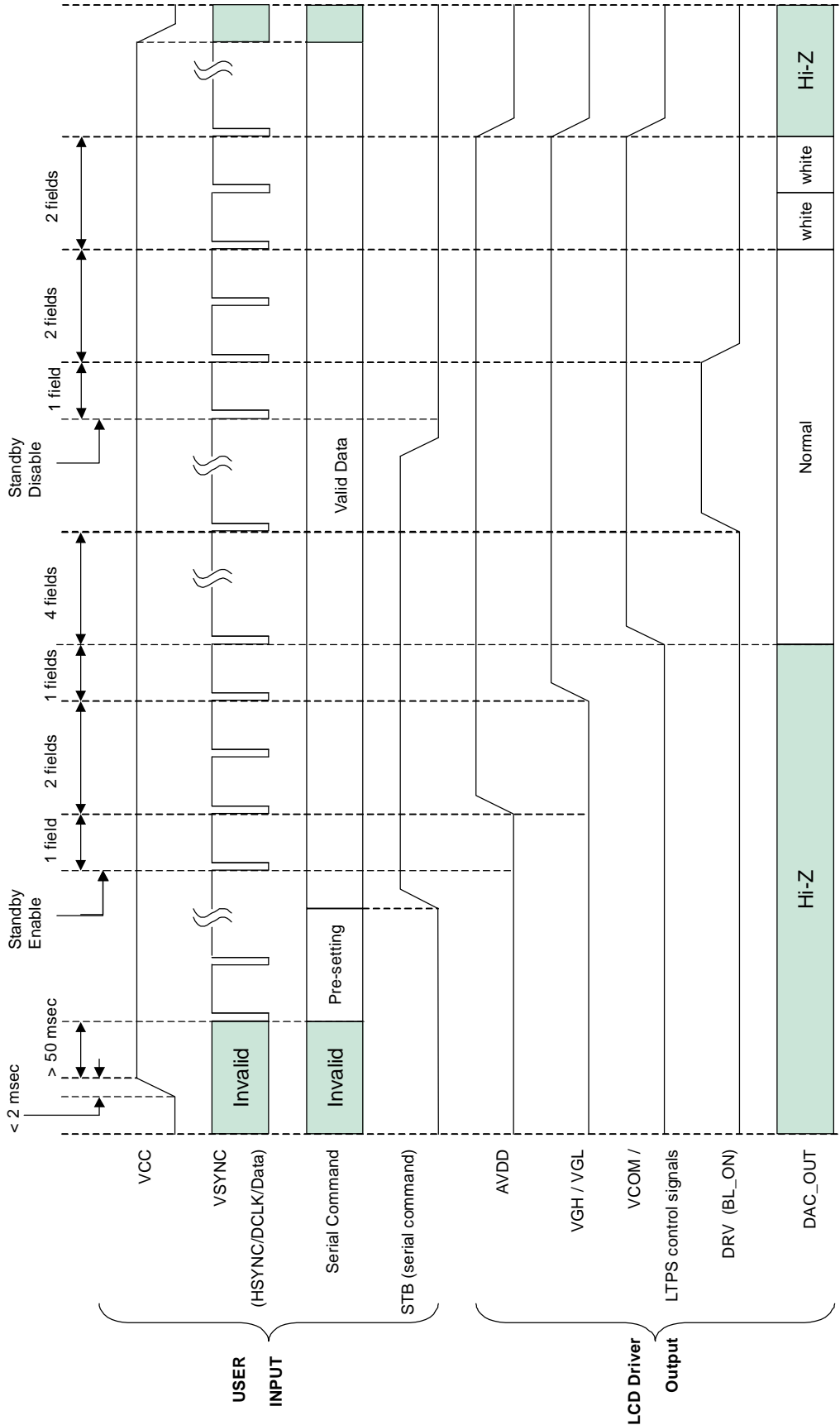
### 3-4 Register#0 Setting

If the applied serial program timing is the same as definition of Fig.5, please ignore this section. If the first edge of serial clock (SCL) is low edge after CS goes low, an unintended command as R0=00h is programmed.

The serial command data (SDA) is latched at each rising edge of SCL. A 4-bit clock counter is used to count the receiving command data. A command is defined as programming completed and loaded under two conditions: (1) the clock counter is 0000'b and (2) SCL low edge is asserted at CS low period.

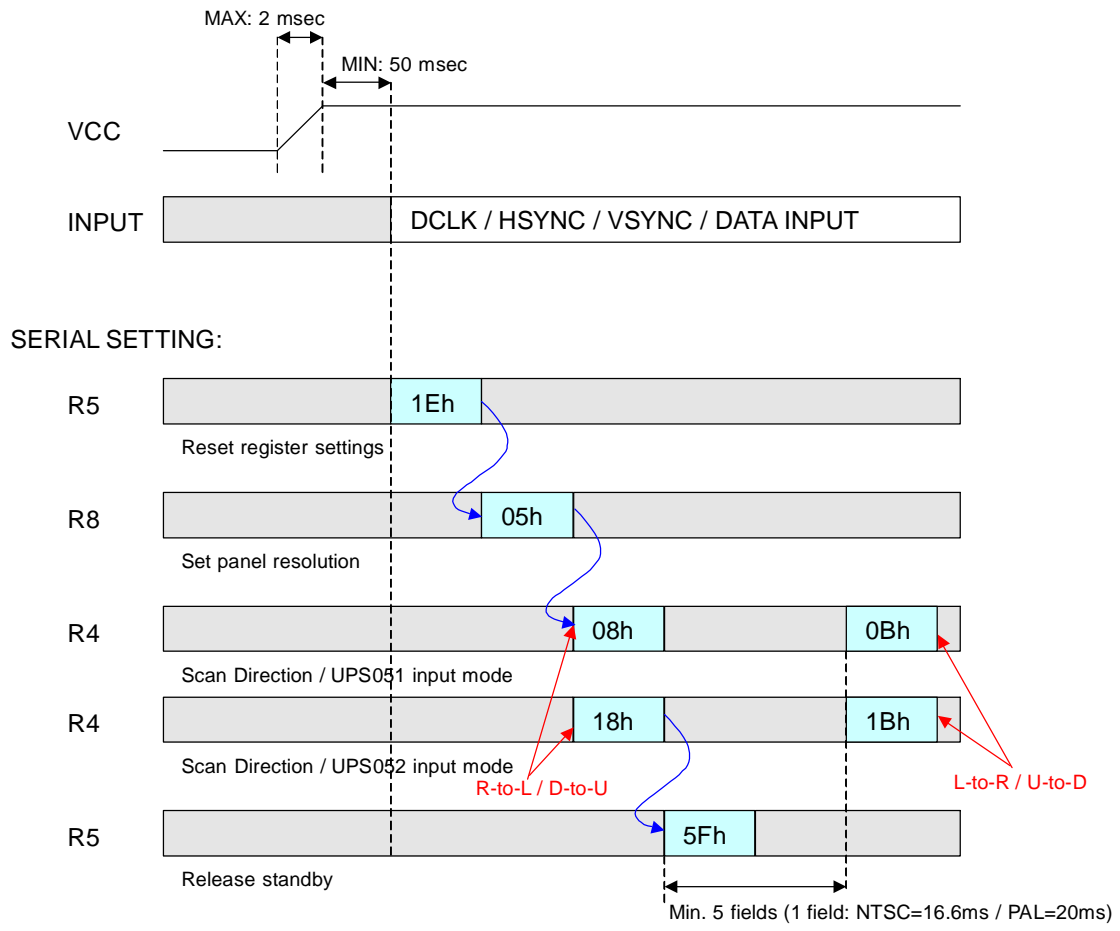
The 4-bit clock counter is set to 0000'b while 16 bits of data are received at CS low or the serial interface block is reset. The initial state of serial interface latching register is address=00h and data=00h (which is R0=00h). Therefore, if the serial clock SCL is normally high and the first edge of SCL is falling edge, an unintended command as R0=00h is loaded. To avoid this unintended R0=00h setting, a R0 setting must be added at the end of multiple serial command setting.

Note: The Power ON/OFF Sequence of Internal and external LED driver circuit are the same.

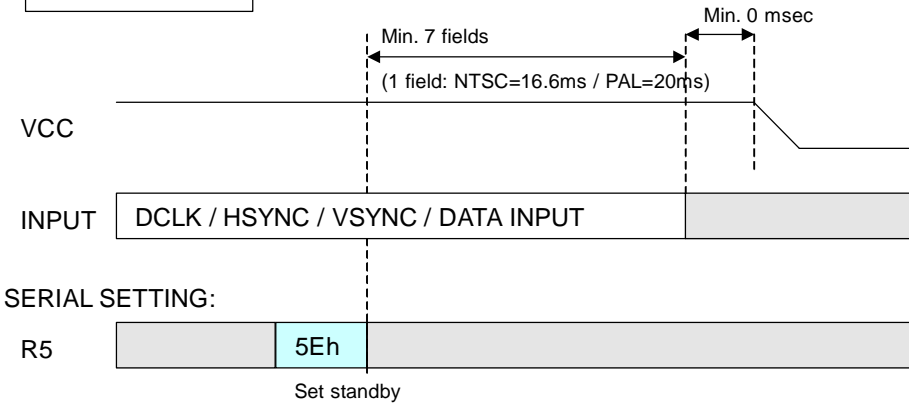


**Fig.14 Power ON / OFF Sequence**

**POWER ON**



**POWER OFF**



**Fig 15. Recommend Serial Command Settings**