

# mass integrated

global part distribution • product lifecycle partner  
excess inventory management • value-ad service provider



Data sheet provided by Mass Integrated

[massintegrated.com](http://massintegrated.com) • [displayalliance.com](http://displayalliance.com)

Please call +1.978.465.6190  
Email: [sales@massintegrated.com](mailto:sales@massintegrated.com)



ISO 9001: 2008

Mass Integrated complies with all DMCA takedown notices. Please send a formal DMCA Takedown Notice to Mass Integrated Systems, Inc. • 18 Henry Graf Jr. Road, Unit 1 • Newburyport, MA 01950.



晶采光電科技股份有限公司  
AMPIRE CO., LTD.

## SPECIFICATIONS FOR LCD MODULE

<b>CUSTOMER</b>	
<b>CUSTOMER PART NO.</b>	
<b>AMPIRE PART NO.</b>	<b>AM-800600C3TMQW-TB1H</b>
<b>APPROVED BY</b>	
<b>DATE</b>	

Approved For Specifications

Approved For Specifications & Sample

**AMPIRE CO., LTD.**

**2F., No.88, Sec. 1, Sintai 5th Rd., Sijhih City, Taipei County 221,  
Taiwan (R.O.C.)台北縣汐止市新台五路一段 88 號 2 樓(東方科學園區 D 棟)**

**TEL:886-2-26967269 , FAX:886-2-26967196 or 26967270**

<b>APPROVED BY</b>	<b>CHECKED BY</b>	<b>ORGANIZED BY</b>

## RECORD OF REVISION

Revision Date	Page	Contents	Editor
2009/12/08	--	New Release	Emil

## 1. Features

8 inch Amorphous-TFT-LCD (Thin Film Transistor Liquid Crystal Display) module. This module is composed of a 8" TFT-LCD panel, LED backlight and power circuit unit and LED driver unit.

- (1) Construction: 8" a-Si TFT active matrix, White LED Backlight.
- (2) Resolution (pixel): 800(R.G.B) X600
- (3) Number of the Colors : 262K colors ( R , G , B 6 bit digital each)
- (4) LCD type : Transmissive , normally White
- (5) Interface: 20 Pin (LVDS interface)
- (6) Power Supply Voltage: 3.3V for logic voltage, 5.0V for LED driver power voltage.
- (7) Viewing Direction: 6 O'clock ( The direction it's hard to be discolored )

## 2. PHYSICAL SPECIFICATIONS

Item	Specifications	unit
LCD size	8 inch (Diagonal)	
Resolution	800 x 3(RGB) x 600	dot
Dot pitch	0.0675(W) x 0.2025(H)	mm
Active area	162.0(W) x 121.5(H)	mm
Module size	183.0(W) x 141.0(H) x 10.46(D)	mm
Surface treatment	Anti-Glare	
Color arrangement	RGB-stripe	
interface	Digital	
Weight	T.B.D	g

### 3. ABSOLUTE MAX. RATINGS

Item	Symbol	Values		UNIT	Note
		Min.	Max.		
Power voltage	VCC	-0.3	+6.0	V	
	VLED	-0.3	6.0		
Input signal voltage	Vi	-0.3	VCC+0.3	V	Note 1
Operation temperature	TOP	-20	70	°C	
Storage temperature	TST	-30	80	°C	

Note 1: The product is subject to be damaged permanently if stresses beyond those absolute maximum ratings listed above.

### 4. ELECTRICAL CHARACTERISTICS

#### 4-1 Typical Operation Conditions

Item	Symbol	Values			Unit	Remark
		MIN	TYP	MAX		
Power Voltage	V <sub>CC</sub>	3.0	3.3	3.6	V	Note 1,2
Power Consumption	I <sub>CC</sub>	--	160	--	mA	Note 1,2 VCC=3.3V
LED Driver Power Voltage	V <sub>LED</sub>	4.5	5.0	5.5	V	
LED Driver Current Consumption	I <sub>LED</sub>	--	410	--	mA	VLED=5V VADJ=3.3V (duty 100%)
Logic input high voltage	V <sub>iH</sub>	0.7 V <sub>CC</sub>	-	V <sub>CC</sub>	V	Note 3
Logic input low voltage	V <sub>iL</sub>	GND	-	0.3 V <sub>CC</sub>	V	Note 3

Note 1: Value for Power Board combined panel.

Note 2: VCC setting should match the signals output voltage (refer to Note 3) of customer's system board.

Note 3: DCLK,HS,VS,RSTB,UPDN,STLR,MODE,DITHB.

## 4-2 Backlight Driving Conditions

Item	Symbol	Values			Unit	Note
		Min.	Typ.	Max.		
LED voltage	VL	9.3	9.9	10.5	V	Note 1
LED current	IL	162	180	198	mA	Note 1
LED life time	--	20,000	--	--	Hr	Note 2

Note 1 : The LED Supply Voltage is defined by the number of LED at  $T_a=25^{\circ}\text{C}$  and  $I_L=180\text{mA}$ .

Note 2 : The "LED life time" is defined as the module brightness decrease to 50% original brightness at  $T_a=25^{\circ}\text{C}$  and  $I_L=180\text{mA}$ . The LED lifetime could be decreased if operating  $I_L$  is larger than 180mA.

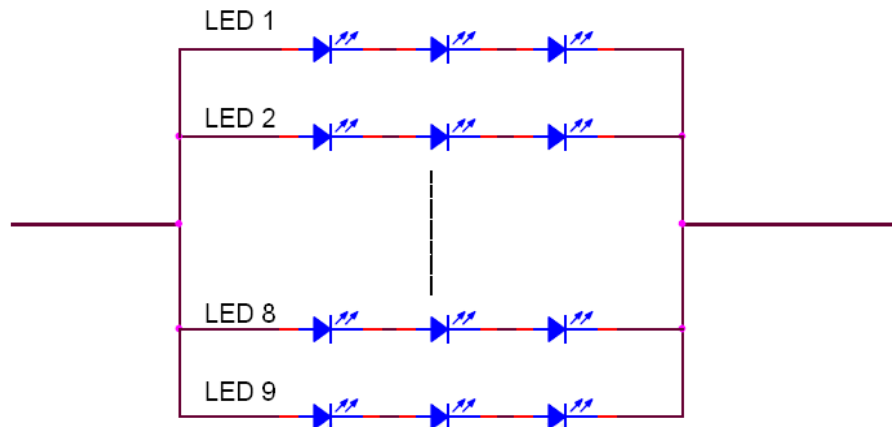

Note 3 : When LCM is operated over  $40^{\circ}\text{C}$  ambient temperature, the  $I_{LED}$  should be follow :

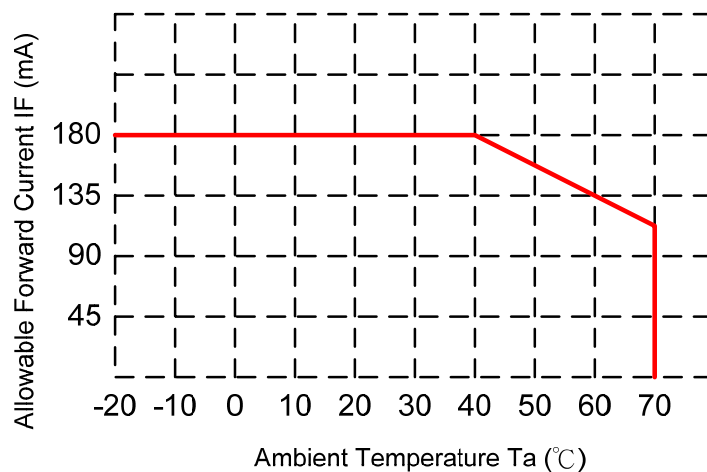

### 4-3 Power Sequence

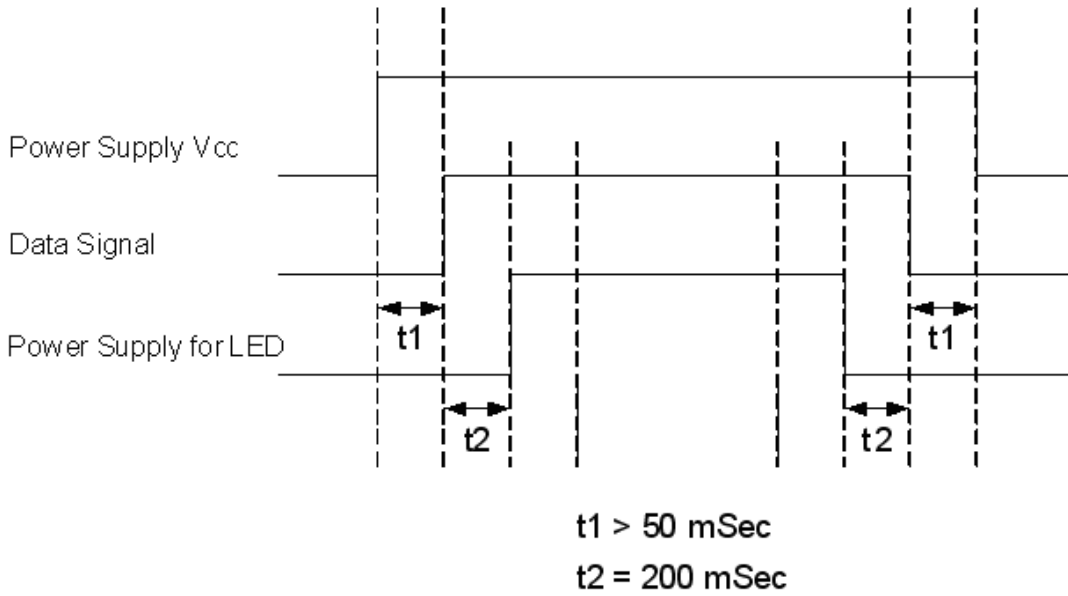

### 4-4 Block Diagram

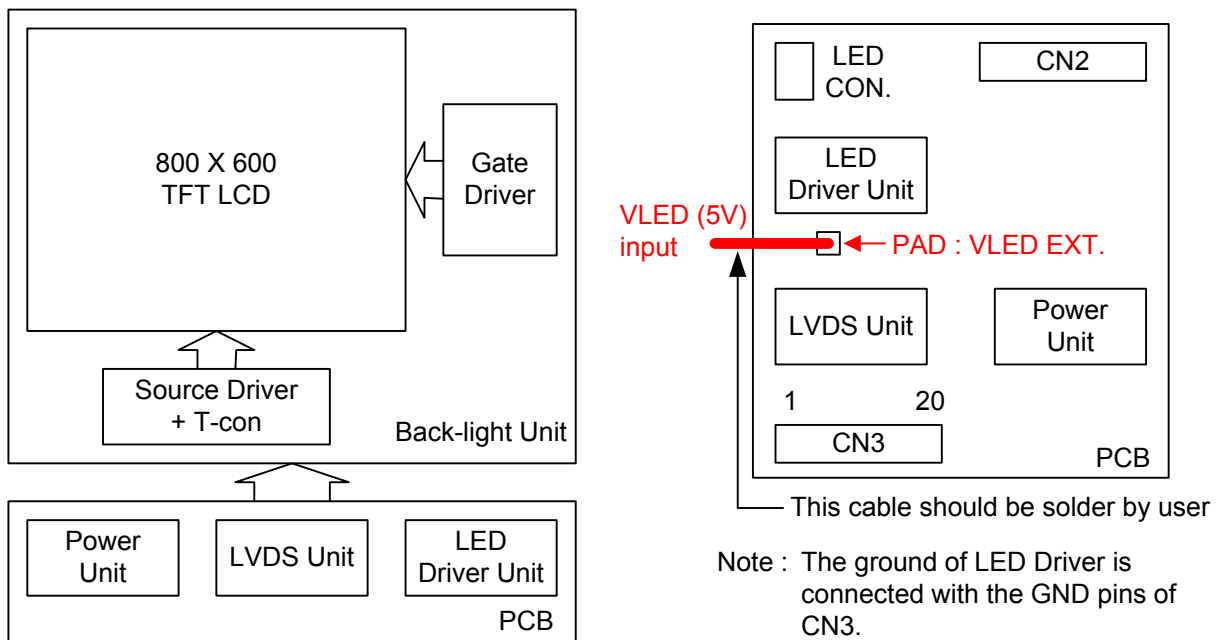

## 5. Optical Specifications

Item	Symbol	Condition	Values			Unit	Note
			Min.	Typ.	Max.		
Viewing angle (CR $\geq$ 10)	$\theta L$	$\Phi = 180^\circ$ (9 o'clock)	60	70	--	degree	Note1
	$\theta R$	$\Phi = 0^\circ$ (3 o'clock)	60	70	--		
	$\theta T$	$\Phi = 90^\circ$ (12 o'clock)	40	50	--		
	$\theta B$	$\Phi = 270^\circ$ (6 o'clock)	60	70	--		
Response time	TON	Normal $\theta = \Phi = 0^\circ$	--	10	20	msec	Note3
	TOFF		--	15	30	msec	
Contrast ratio	CR		320	400	--	--	Note4
Color chromaticity	WX		0.26	0.31	0.36	--	Note5
	WY		0.28	0.33	0.38	--	Note6
Luminance	L		200	250	--	cd/m <sup>2</sup>	Note6
Luminance uniformity	YU		70	75	--	%	Note7

Test Conditions :

1. VCC = 3.3V, I<sub>L</sub> = 180mA (Backlight current), the ambient temperature is 25°C.
2. The test systems refer to Note 2.

Note 1 : Definition of viewing angle range

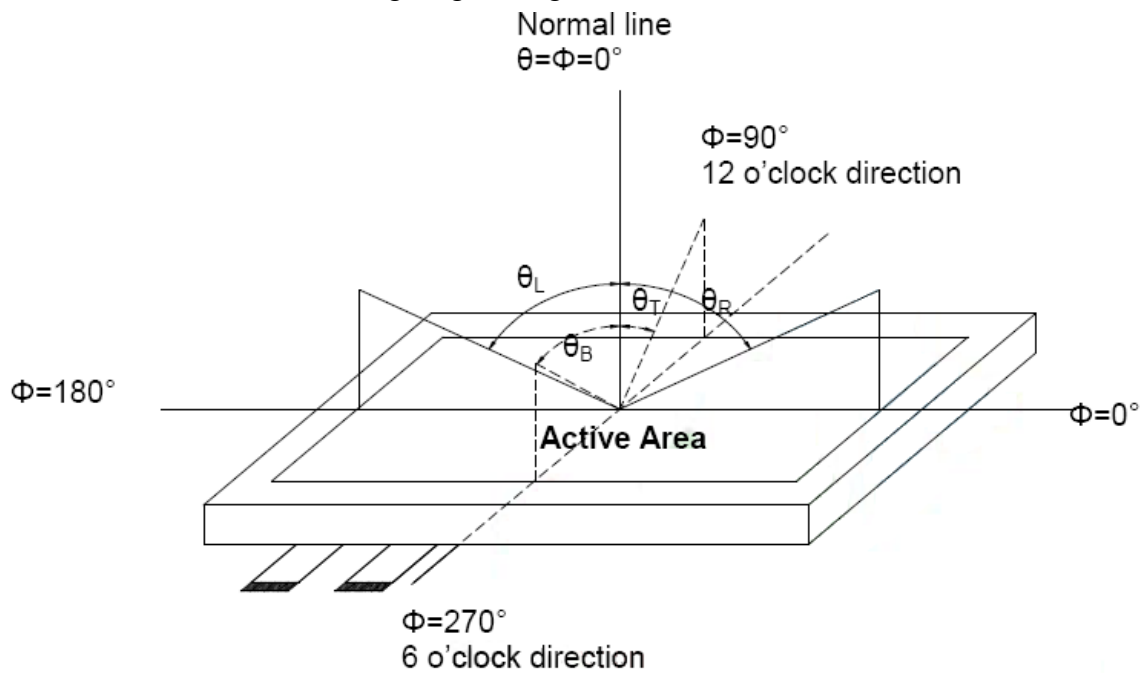

Note 2 : Definition of optical measurement system.

The optical characteristics should be measured in dark room. After 30 minutes operation, the optical properties are measured at the center point of the LCD screen. (Response time is measured by Photo detector TOPCON BM-7, other items are measured by BM-5A/Field of view : 1° / Height : 500mm.)

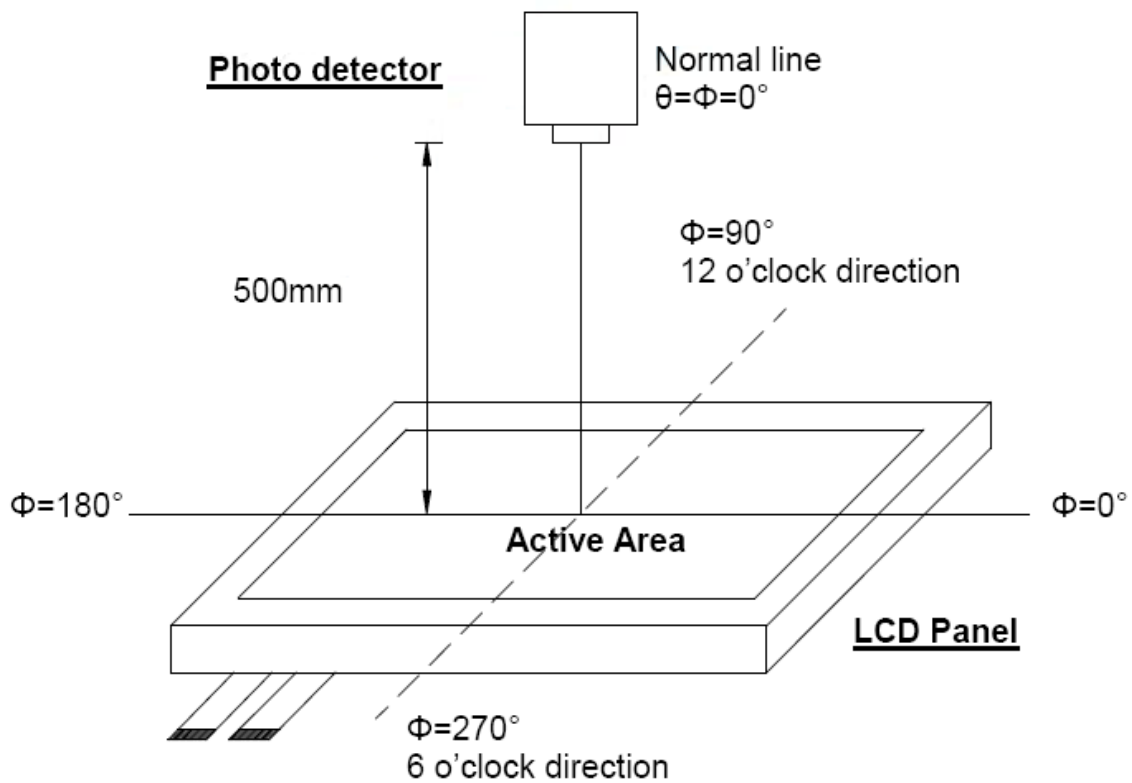

Note 3 : Definition of Response time

The response time is defined as the LCD optical switching time interval between “White” state and “Black” state. Rise time ( $T_{ON}$ ) is the time between photo detector output intensity changed from 90% to 10%. And fall time ( $T_{OFF}$ ) is the time between photo detector output intensity changed from 10% to 90%.

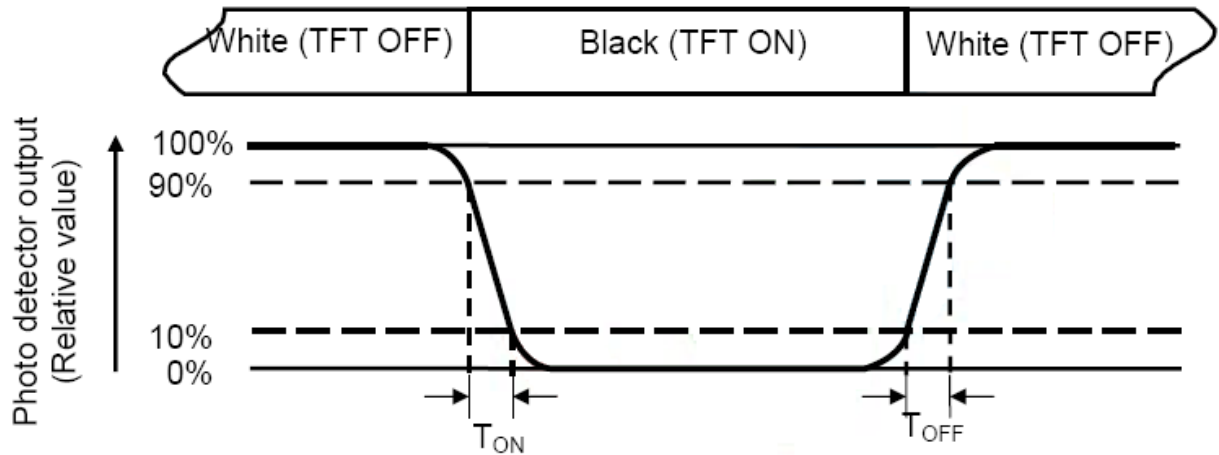

Note 4 : Definition of contrast ratio

$$\text{Contrast ratio (CR)} = \frac{\text{Luminance measured when LCD on the "White" state}}{\text{Luminance measured when LCD on the "Black" state}}$$

Note 5 : Definition of color chromaticity (CIE1931)

Color coordinated measured at center point of LCD.

Note 6 : All input terminals LCD panel must be ground when measuring the center area of the panel.

Note 7 : Definition of Luminance Uniformity

Active area is divided into 9 measuring areas (Refer to bellow figure). Every measuring point is placed at the center of each measuring area.

$$\text{Luminance Uniformity (Yu)} = \frac{B_{\min}}{B_{\max}}$$

L ----- Active area length      W ----- Active area width

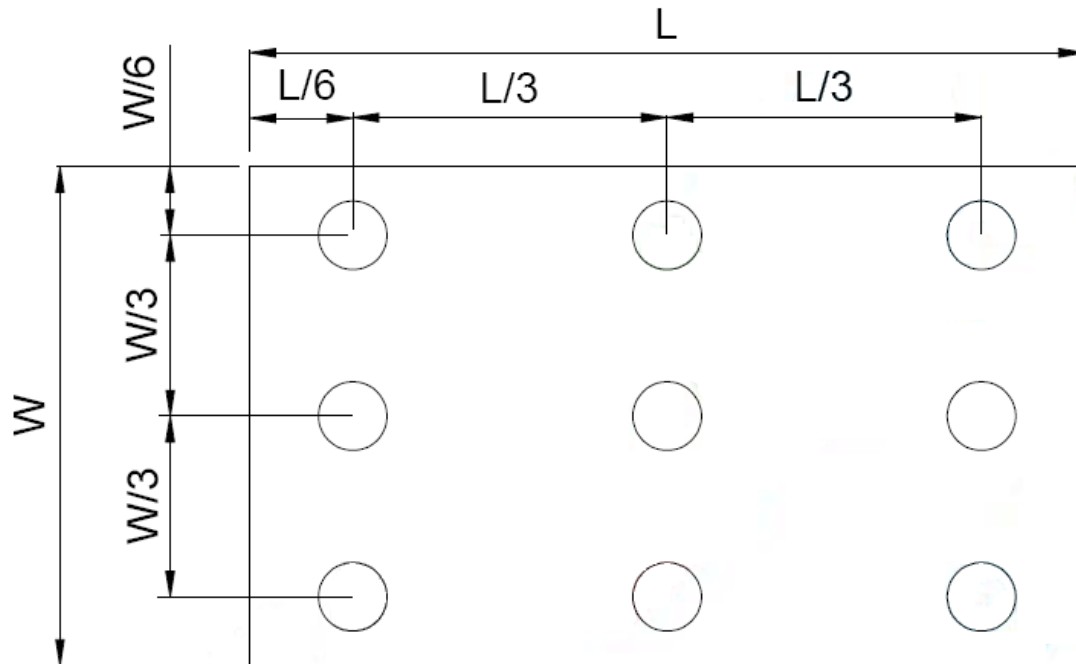

$B_{\max}$  : The measured maximum luminance of all measurement position.

$B_{\min}$  : The measured minimum luminance of all measurement position.

## 6. INTERFACE

### TFT LCD Panel Driving Section

Pin No.	Symbol	Description	Note
1	VDD	POWER SUPPLY:3.3V	
2	VDD	POWER SUPPLY:3.3V	
3	Gnd	Power Ground	
4	Gnd	Power Ground	
5	IN0-	Transmission Data	
6	IN0+	Transmission Data	
7	Gnd	Power Ground	
8	IN1-	Transmission Data	
9	IN1+	Transmission Data	
10	Gnd	Power Ground	
11	IN2-	Transmission Data	
12	IN2+	Transmission Data	
13	Gnd	Power Ground	
14	CLK-	Sampling Clock	
15	CLK+	Sampling Clock	
16	Gnd	Power Ground	
17	ADJ	Adjust the LED brightness	(1)
18	NC	No Connect	
19	Gnd	Power Ground	
20	Gnd	Power Ground	

NOTE :

(1) Pin17: ADJ is PWM signal input. It is for brightness control.

ITEM	SYMBOL	MIN	TYP	MAX	UNIT
ADJ signal frequency	$f_{PWM}$	100	--	1K	Hz
ADJ signal logic level High	$V_{IH}$	2V	--	$V_{LED}$ (5.0V)	V
ADJ signal logic level Low	$V_{IL}$	0	--	0.5	V

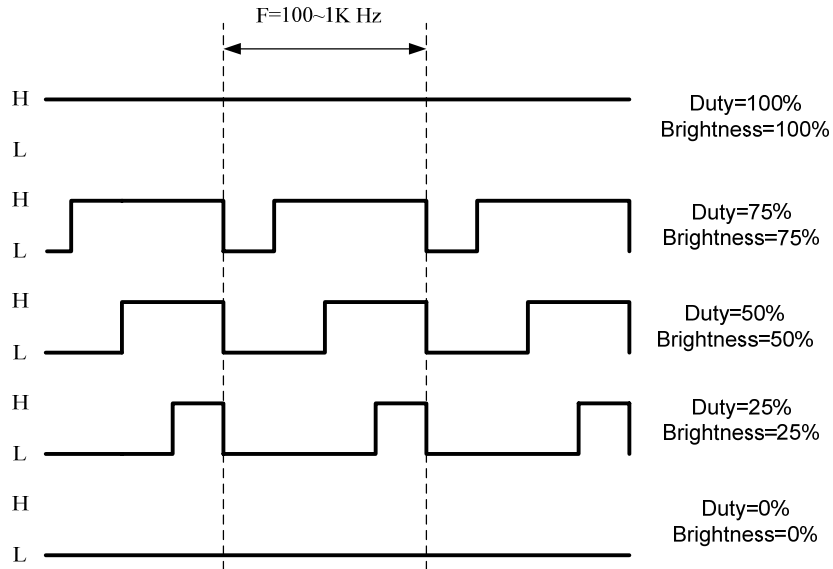

## 7. INTERFACE TIMING (The information as below is to be defined.)

### 7-1 LVDS SIGNAL :

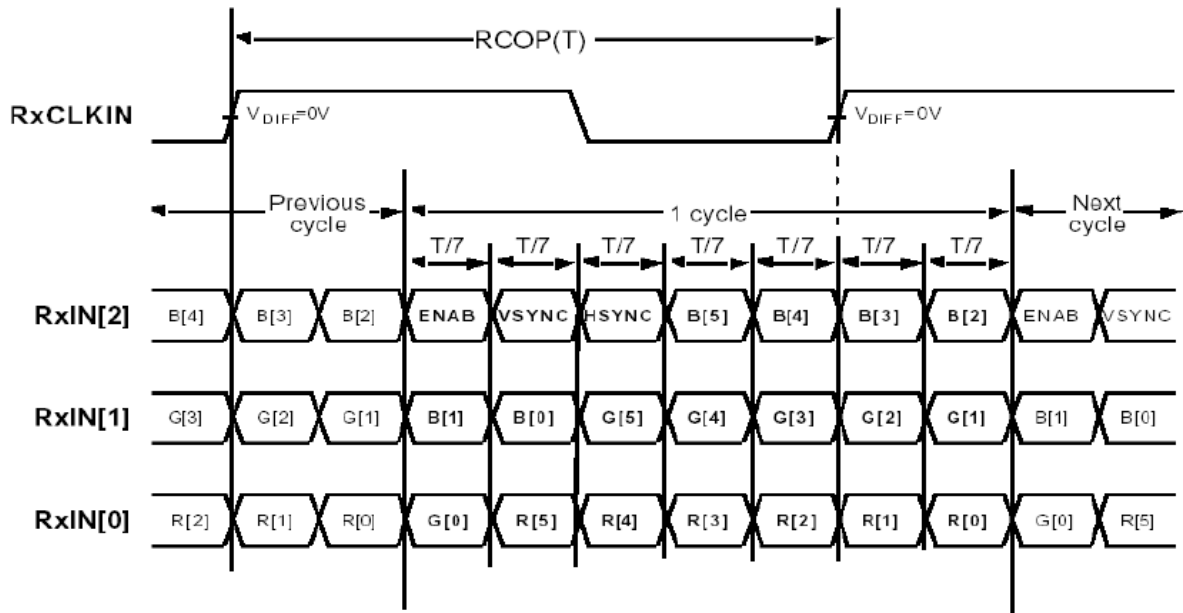

Note : R/G/B[5]s are MSBs and R/G/B[0]s are LSBs

### 7-2 LVDS AC Timing Diagram :

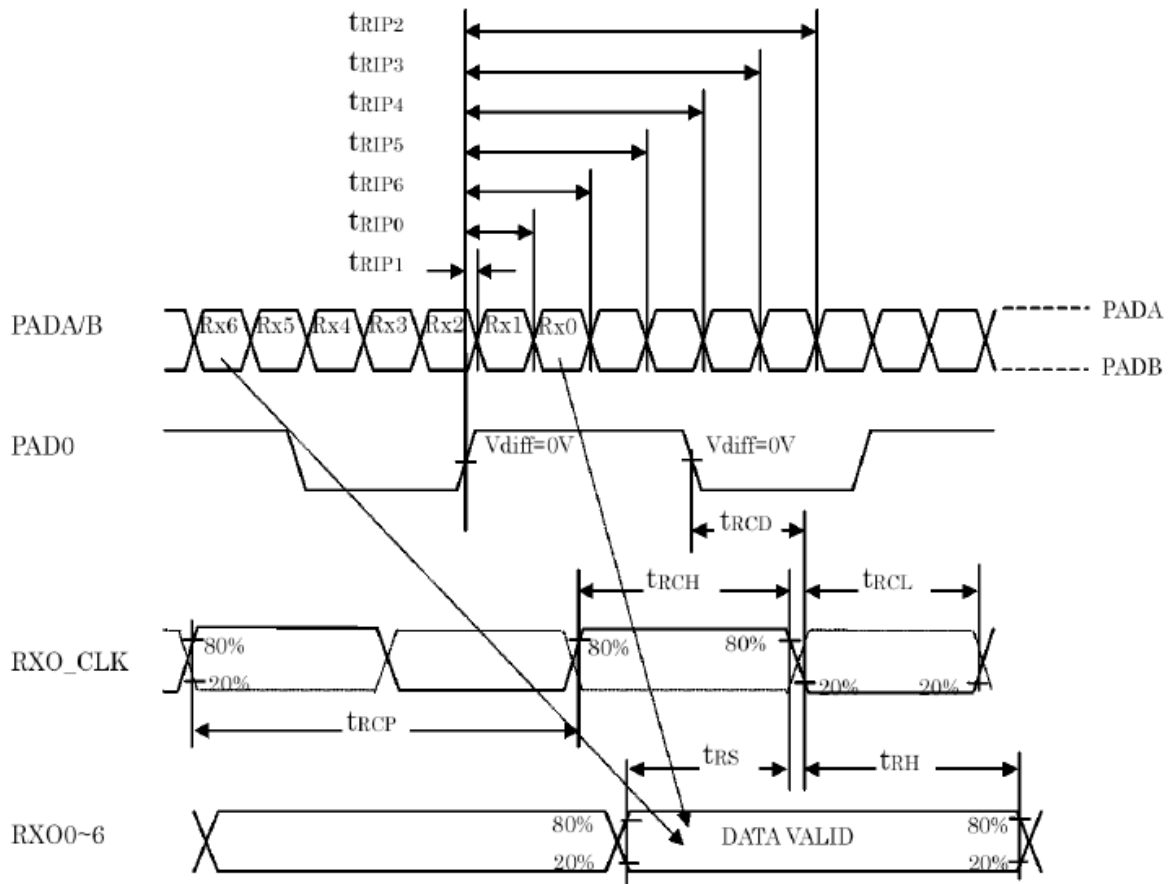

### 7-3 Phase Lock Loop Set Time :

(Case1)

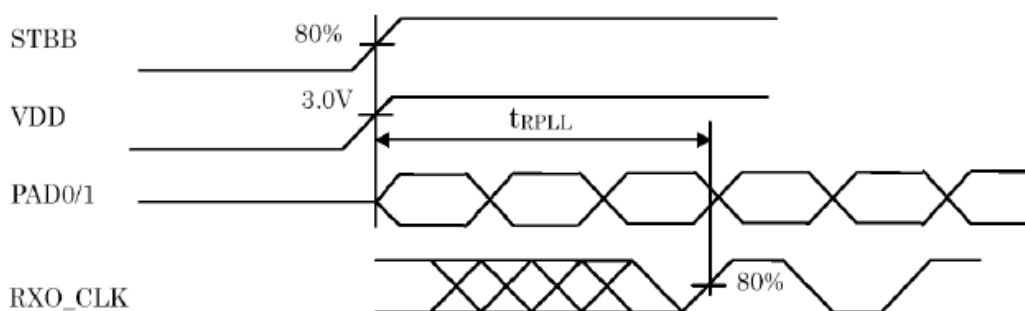

(Case2)

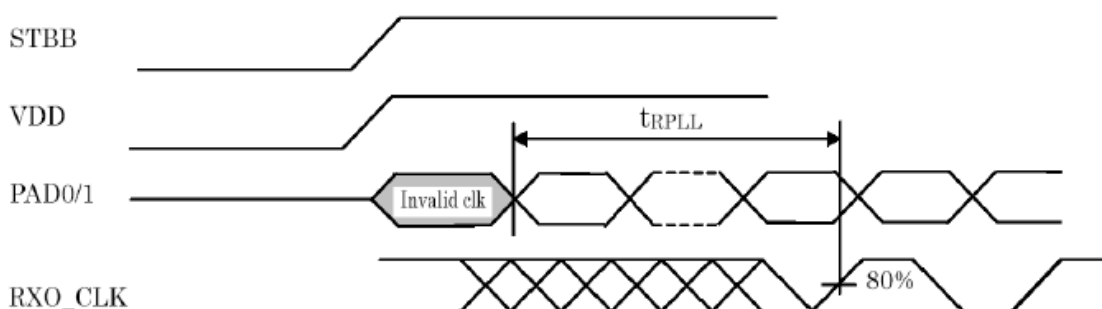

### 7-4 Switching Characteristics :

< recommended operating condition (unless otherwise noted) >

Parameter	Symbol	min	typ	max	Unit
RXO_CLK Period	$t_{RCP}$	11.76	T	50	ns
RXO_CLK High Time	$t_{RCH}$	-	T/2	-	ns
RXO_CLK Low Time	$t_{RCL}$	-	T/2	-	ns
PAD0/1 to RXO_CLK Delay	$t_{RCD}$	-	3T/7	-	ns
Data Setup to RXO_CLK	$t_{RS}$	1.9	-	-	ns
Data Hold from RXO_CLK	$t_{RH}$	3.0	-	-	ns
Input Data Position 0 (T=11.76ns) (note1)	$t_{RIP1}$	-0.4	0	0.4	ns
Input Data Position 1 (T=11.76ns) (note1)	$t_{RIP0}$	T/7-0.4	T/7	T/7+0.4	ns
Input Data Position 2 (T=11.76ns) (note1)	$t_{RIP6}$	2T/7-0.4	2T/7	2T/7+0.4	ns
Input Data Position 3 (T=11.76ns) (note1)	$t_{RIP5}$	3T/7-0.4	3T/7	3T/7+0.4	ns
Input Data Position 4 (T=11.76ns) (note1)	$t_{RIP4}$	4T/7-0.4	4T/7	4T/7+0.4	ns
Input Data Position 5 (T=11.76ns) (note1)	$t_{RIP3}$	5T/7-0.4	5T/7	5T/7+0.4	ns
Input Data Position 6 (T=11.76ns) (note1)	$t_{RIP2}$	6T/7-0.4	6T/7	6T/7+0.4	ns
Phase Lock Loop Set	$t_{RPLL}$	-	-	10	ms

note1 : VDD=3.3V, Ta=25°C

## 7-5 DE MODE SIGNAL :

### 7-5-1 AC Electrical Characteristics

Item	Symbol	Values			Unit	Remark
		Min.	Typ.	Max.		
HS setup time	$T_{hst}$	8	-	-	Ns	
HS hold time	$T_{hhd}$	8	-	-	Ns	
VS setup time	$T_{vst}$	8	-	-	Ns	
VS hold time	$T_{vhd}$	8	-	-	Ns	
Data setup time	$T_{dsu}$	8	-	-	Ns	
Data hole time	$T_{dhd}$	8	-	-	Ns	
DE setup time	$T_{esu}$	8	-	-	Ns	
DE hole time	$T_{ehd}$	8	-	-	Ns	
VDD Power On Slew rate	$T_{POR}$	-	-	20	ms	
RSTB pulse width	$T_{Rst}$	10	-	-	us	
CLKIN cycle time	$T_{coh}$	20	-	-	Ns	
CLKIN pulse duty	$T_{cwh}$	40	50	60	%	
Output stable time	$T_{sst}$	-	-	6	us	

## 7-5-2 Timing

Item	Symbol	Values			Unit	Remark
		Min.	Typ.	Max.		
Horizontal Display Area	thd	-	800	-	DCLK	
DCLK Frequency	fclk	-	40	50	MHz	
One Horizontal Line	th	862	1056	1200	DCLK	
HS pulse width	thpw	1	-	40	DCLK	
HS Back Porch(Blanking)	thb	46	46	46	DCLK	
HS Front Porch	thfp	16	210	354	DCLK	

Item	Symbol	Values			Unit	Remark
		Min.	Typ.	Max.		
Vertical Display Area	tvd	-	600	-	TH	
VS period time	tv	624	635	700	TH	
VS pulse width	tvpw	1	-	20	TH	
VS Back Porch(Blanking)	tvb	23	23	23	TH	
VS Front Porch	tvfp	1	12	77	TH	

## 7-5-3 Input Clock and Data Timing Diagram

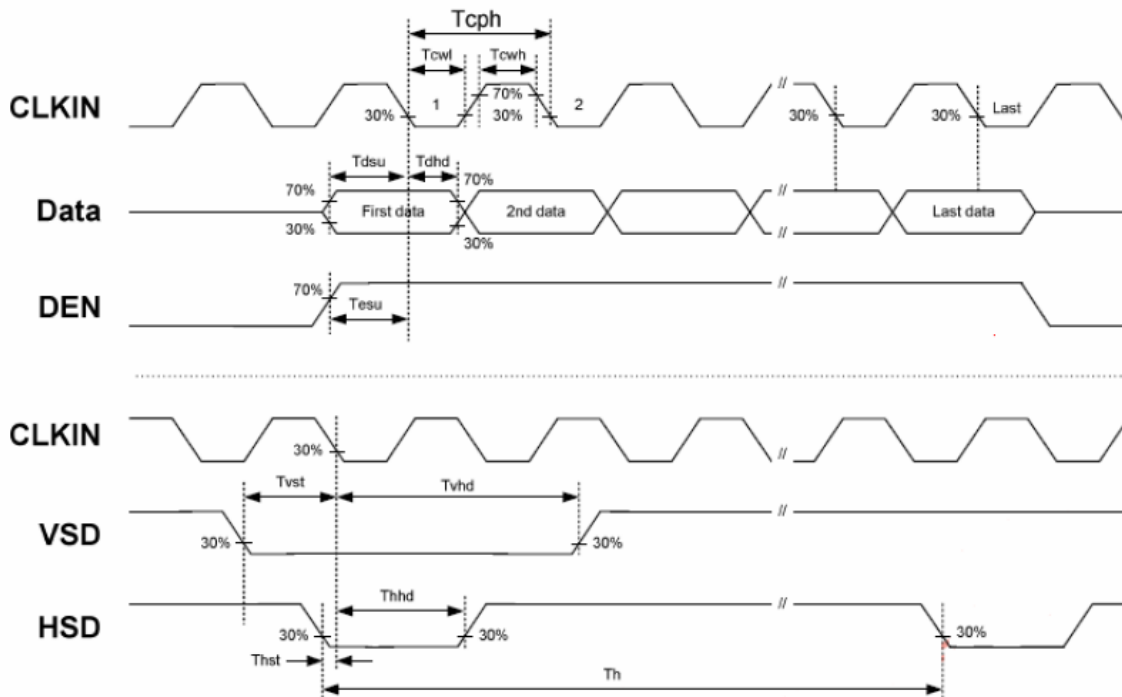

## 8. RELIABILITY TEST CONDITIONS

(Note 3)

Item	Test Conditions	Note
High Temperature Storage	Ta = 80°C 240 hrs	Note 1,4
Low Temperature Storage	Ta = -30°C 240 hrs	Note 1,4
High Temperature Operation	Ts = 70°C 240 hrs	Note 2,4
Low Temperature Operation	Ta = -20°C 240 hrs	Note1,4
Operate at High Temperature and Humidity	+40°C, 90%RH 240 hrs	
Thermal Shock	-30°C /30 min ~ +80°C /30 min for a total 100 cycles, Start with cold temperature and end with high temperature	
Vibration Test	Frequency range : 10 ~ 55Hz Stroke : 1.5mm Sweep : 10Hz ~ 55Hz ~ 10Hz 2 hours for each direction of X. Y. Z. (6 hours for total)	
Mechanical Shock	100G 6ms, ±X, ±Y, ±Z 3 times for each direction	
Package Vibration Test	Random Vibration : 0.015G*G/Hz from 5-200HZ, -6dB/Octave from 200-500Hz 2 hours for each direction of X. Y. Z. (6 hours for total)	
Package Drop Test	Height : 60 cm 1 comer, 3 edges, 6 surfaces	
Electro Static Discharge	±2KV, Human Body Mode, 100pF/1500Ω	

Note 1 : Ta is the ambient temperature of samples.

Note 2 : Ts is the temperature of panel's surface.

Note 3 : In the standard condition, there shall be no practical problem that may affect the display function. After the reliability test, the product only guarantees operation, but don't guarantee all of the cosmetic specification.

Note 4 : Before cosmetic and function test, the product must have enough recovery time, at least 2 hours at room temperature.

## Display Quality

### 1. Function Related :

The function defects of line defect, abnormal display, and no display are considered Major defects.

### 2. Bright / Dark Dots :

Defect Type	Specification	Major	Minor
Bright Dots	N ≤ 5		●

Note : The definition of dot : The size of a defective dot over 1/2 of whole dot is regarded as one defective dot.

Bright dot : Dots appear bright and unchanged in size in which LCD panel is displaying under black pattern.

Dark dot : Dots appear dark and unchanged in size in which LCD panel is displaying under pure red, green, blue pattern.

### 3. Pixel Definition :

R	G	B	R	G	B	R	G	B			Dot Defect
R	G	B	R	G	B	R	G	B			Adjacent Dot Defect
R	G	B	R	G	B	R	G	B			Cluster

Note 1: If pixel or partial sub-pixel defects exceed 50% of the affected pixel or sub-pixel area, it shall be considered as 1 defect.

Note 2: Extraneous substance and scratch not affecting the display of image, for instance, extraneous substance under polarizer film but outside the display area, or scratch on metal bezel and backlight module or polarizer film outside the display area, shall not be considered as defective or non-conforming.

## **9. General Precautions**

### **9-1 Safety**

Liquid crystal is poisonous. Do not put it your mouth. If liquid crystal touches your skin or clothes, wash it off immediately by using soap and water.

### **9-2 Handling**

1. The LCD panel is plate glass. Do not subject the panel to mechanical shock or to excessive force on its surface.
2. The polarizer attached to the display is easily damaged. Please handle it carefully to avoid scratch or other damages.
3. To avoid contamination on the display surface, do not touch the module surface with bare hands.
4. Keep a space so that the LCD panels do not touch other components.
5. Put cover board such as acrylic board on the surface of LCD panel to protect panel from damages.
6. Transparent electrodes may be disconnected if you use the LCD panel under environmental conditions where the condensation of dew occurs.
7. Do not leave module in direct sunlight to avoid malfunction of the ICs.

### **9-3 Static Electricity**

1. Be sure to ground module before turning on power or operation module.
2. Do not apply voltage which exceeds the absolute maximum rating value.

### **9-4 Storage**

1. Store the module in a dark room where must keep at  $+25\pm 10^{\circ}\text{C}$  and 65%RH or less.
2. Do not store the module in surroundings containing organic solvent or corrosive gas.
3. Store the module in an anti-electrostatic container or bag.

### **9-5 Cleaning**

1. Do not wipe the polarizer with dry cloth. It might cause scratch.
2. Only use a soft sloth with IPA to wipe the polarizer, other chemicals might permanent damage to the polarizer.

### **9-5 Others**

1. AMIPRE will provide one year warrantee for all products and three months warrantee for all repairing products.

