

mass integrated

global part distribution • product lifecycle partner
excess inventory management • value-ad service provider



Data sheet provided by Mass Integrated

massintegrated.com • displayalliance.com

Please call +1.978.465.6190
Email: sales@massintegrated.com



ISO 9001: 2008

Mass Integrated complies with all DMCA takedown notices. Please send a formal DMCA Takedown Notice to Mass Integrated Systems, Inc. • 18 Henry Graf Jr. Road, Unit 1 • Newburyport, MA 01950.



Product Specification

AU OPTRONICS CORPORATION

() Preliminary Specifications

() Final Specifications

Module	10.1" WSVGA Color TFT-LCD with LED Backlight design
Model Name	B101AW03 V0
Note ()	<i>LED Backlight with driving circuit design</i>

Customer	Date
Checked & Approved by	Date
_____	_____
<p>Note: This Specification is subject to change without notice.</p>	

Approved by	Date
<u>Howard Lee</u>	<u>09/30/2008</u>
Prepared by	
<u>Winston Lin</u>	<u>09/30/2008</u>
<p>NBBU Marketing Division / AU Optronics corporation</p>	



Contents

1. Handling Precautions	4
2. General Description	5
2.1 General Specification.....	5
2.2 Optical Characteristics.....	6
3. Functional Block Diagram	11
4. Absolute Maximum Ratings	12
4.1 Absolute Ratings of TFT LCD Module.....	12
4.2 Absolute Ratings of Environment.....	12
5. Electrical characteristics	13
5.1 TFT LCD Module.....	13
5.2 Backlight Unit.....	15
6. Signal Characteristic.....	16
6.1 Pixel Format Image	16
6.2 The input data format	16
6.3 Integration Interface and Pin Assignment	18
6.4 Interface Timing	19
7. Connector Description.....	22
7.1 TFT LCD Module.....	22
8. LED Driving Specification	23
8.1 Connector Description	23
8.2 Pin Assignment	23
9. Vibration and Shock Test	24
9.1 Vibration Test	24
9.2 Shock Test Spec:.....	24
10. Reliability.....	25
11. Mechanical Characteristics	26
11.1 LCM Outline Dimension	26
11.2 Screw Hole Depth and Center Position.....	28
12. Shipping and Package	29
12.1 Shipping Label Format.....	29
12.2 Carton package.....	30
12.3 Shipping package of palletizing sequence.....	31
13. Appendix: EDID description.....	32



Product Specification

AU OPTRONICS CORPORATION

Record of Revision

Version and Date	Page	Old description	New Description	Remark
0.1 2008/09/30	All	First Edition for Customer		
0.2 2008/12/03	21	Panel (LED) LED power sequence	Panel (LED) LED power sequence → waveform & parameter updated	
0.2 2008/12/03	29	Shipping label format	Shipping label format → information updated	
0.2 2008/12/03	32-	EDID description	EDID description → addition	

1. Handling Precautions

- 1) Since front polarizer is easily damaged, pay attention not to scratch it.
- 2) Be sure to turn off power supply when inserting or disconnecting from input connector.
- 3) Wipe off water drop immediately. Long contact with water may cause discoloration or spots.
- 4) When the panel surface is soiled, wipe it with absorbent cotton or other soft cloth.
- 5) Since the panel is made of glass, it may break or crack if dropped or bumped on hard surface.
- 6) Since CMOS LSI is used in this module, take care of static electricity and insure human earth when handling.
- 7) Do not open nor modify the Module Assembly.
- 8) Do not press the reflector sheet at the back of the module to any directions.
- 9) At the insertion or removal of the Signal Interface Connector, be sure not to rotate nor tilt the Interface Connector of the TFT Module.
- 10) After installation of the TFT Module into an enclosure (Notebook PC Bezel, for example), do not twist nor bend the TFT Module even momentarily. At designing the enclosure, it should be taken into consideration that no bending/twisting forces are applied to the TFT Module from outside. Otherwise the TFT Module may be damaged.
- 11) Small amount of materials having no flammability grade is used in the LCD module. The LCD module should be supplied by power complied with requirements of Limited Power Source (IEC60950 or UL1950), or be applied exemption.
- 12) Disconnecting power supply before handling LCD modules, it can prevent electric shock, DO NOT TOUCH the electrode parts, cables, connectors and LED circuit part of TFT module that a LED light bar build in as a light source of back light unit. It can prevent electrostatic breakdown.



2. General Description

B101AW03 V0 is a Color Active Matrix Liquid Crystal Display composed of a TFT LCD panel, a driver circuit, and LED backlight system. The screen format is intended to support the WSVGA (1024(H) x 600(V)) screen and 262k colors (RGB 6-bits data driver) with LED backlight driving circuit. All input signals are LVDS interface compatible.

B101AW03 V0 is designed for a display unit of notebook style personal computer and industrial machine.

2.1 General Specification

The following items are characteristics summary on the table at 25 °C condition:

Items	Unit	Specifications			
Screen Diagonal	[mm]	255.54 (10.1 W")			
Active Area	[mm]	222.72 x 125.28			
Pixels H x V		1024 x 3(RGB) x 600			
Pixel Pitch	[mm]	0.2175 (H) X 0.2088 (V)			
Pixel Format		R.G.B. Vertical Stripe			
Display Mode		Normally White			
White Luminance (ILED=20mA) (Note: ILED is LED current)	[cd/m ²]	200 typ. (5 points average) 170 min. (5 points average)			
Luminance Uniformity		1.25 max. (5 points); 1.6 max (13 points)			
Contrast Ratio		400:1 typ; 300:1 min			
Response Time	[ms]	16 typ / 25 Max			
Nominal Input Voltage VDD	[Volt]	+3.3 typ.			
Power Consumption	[Watt]	2.8 max.			
Weight	[Grams]	190 max.			
Physical Size without inverter, bracket.	[mm]		Min.	Typ.	Max.
		Length	234.5	235.0	235.5
		Width	142.5	143.0	143.5
		Thickness	-	-	5.2
Electrical Interface		1 channel LVDS			
Surface Treatment		Glare, Hardness 3H			
Support Color		262K colors (RGB 6-bit)			



Product Specification

AU OPTRONICS CORPORATION

Temperature Range Operating	[°C]	0 to +50
Storage (Non-Operating)	[°C]	-20 to +60
RoHS Compliance		RoHS Compliance

2.2 Optical Characteristics

The optical characteristics are measured under stable conditions at 25°C (Room Temperature) :

Item	Symbol	Conditions	Min.	Typ.	Max.	Unit	Note
White Luminance $I_{LED}=20mA$		5 points average	170	200	-	cd/m ²	1, 4, 5.
Viewing Angle	θ_R	Horizontal (Right) CR = 10 (Left)	40	45	-	degree	4, 9
	θ_L		40	45	-		
	ψ_H	Vertical (Upper) CR = 10 (Lower)	10	15	-		
	ψ_L		30	35	-		
Luminance Uniformity	δ_{5P}	5 Points	-	-	1.25		1, 3, 4
Luminance Uniformity	δ_{13P}	13 Points	-	-	1.60		2, 3, 4
Contrast Ratio	CR		300	400	-		4, 6
Cross talk	%				4		4, 7
Response Time	T_r	Rising	-	-	-	msec	4, 8
	T_f	Falling	-	-	-		
	T_{RT}	Rising + Falling	-	16	25		
Color / Chromaticity Coordinates	Red	Rx	CIE 1931	-	TBD	-	4
		Ry		-	TBD	-	
	Green	Gx		-	TBD	-	
		Gy		-	TBD	-	
	Blue	Bx		-	TBD	-	
		By		-	TBD	-	
	White	Wx		0.283	0.313	0.343	
		Wy		0.299	0.329	0.359	
NTSC	%		-	45	-		

Note 1: 5 points position (Ref: Active area)

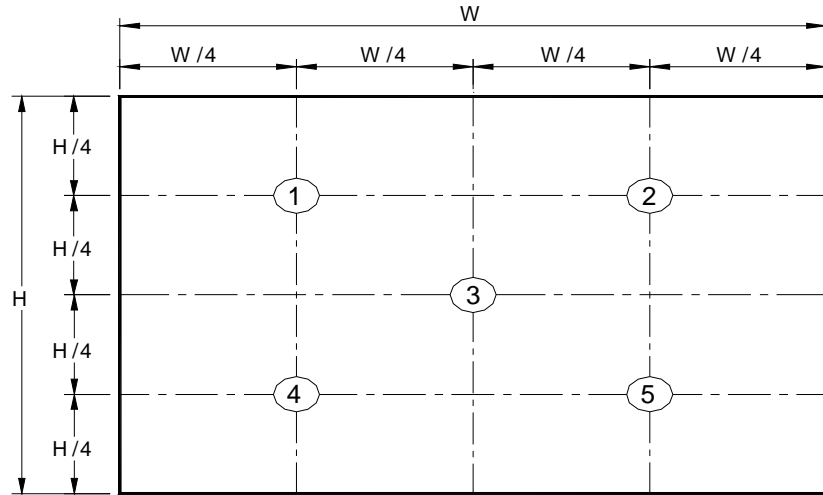

Note 2: 13 points position (Ref: Active area)

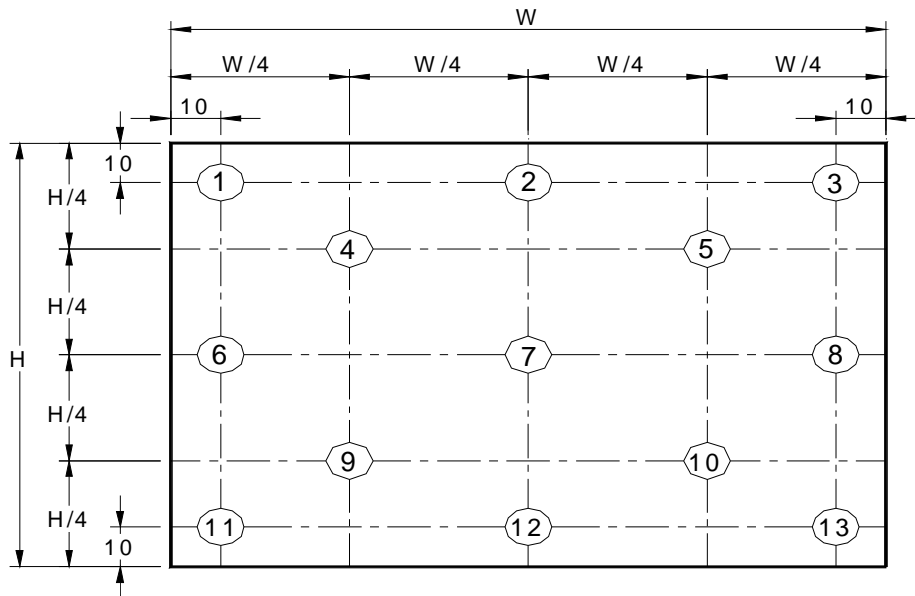

Note 3: The luminance uniformity of 5 or 13 points is defined by dividing the maximum luminance values by the minimum test point luminance

$$\delta_{w5} = \frac{\text{Maximum Brightness of five points}}{\text{Minimum Brightness of five points}}$$

$$\delta_{w13} = \frac{\text{Maximum Brightness of thirteen points}}{\text{Minimum Brightness of thirteen points}}$$

Note 4: Measurement method

The LCD module should be stabilized at given temperature for 30 minutes to avoid abrupt temperature change during measuring. In order to stabilize the luminance, the measurement should be executed after lighting Backlight

for 30 minutes in a stable, windless and dark room, and it should be measured in the center of screen.

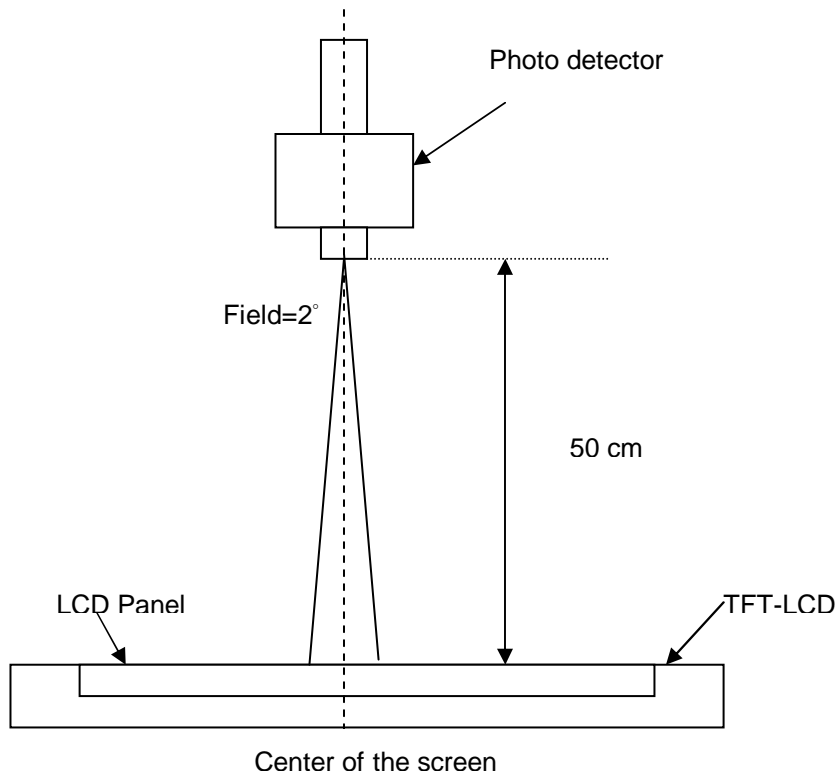

Note 5 : Definition of Average Luminance of White (Y_L):

Measure the luminance of gray level 63 at 5 points , $Y_L = [L (1)+ L (2)+ L (3)+ L (4)+ L (5)] / 5$

$L (x)$ is corresponding to the luminance of the point X at Figure in Note (1).

Note 6 : Definition of contrast ratio:

Contrast ratio is calculated with the following formula.

$$\text{Contrast ratio (CR)} = \frac{\text{Brightness on the "White" state}}{\text{Brightness on the "Black" state}}$$

Note 7 : Definition of Cross Talk (CT)

$$CT = |Y_B - Y_A| / Y_A \times 100 (\%)$$

Where

Y_A = Luminance of measured location without gray level 0 pattern (cd/m²)

Y_B = Luminance of measured location with gray level 0 pattern (cd/m²)

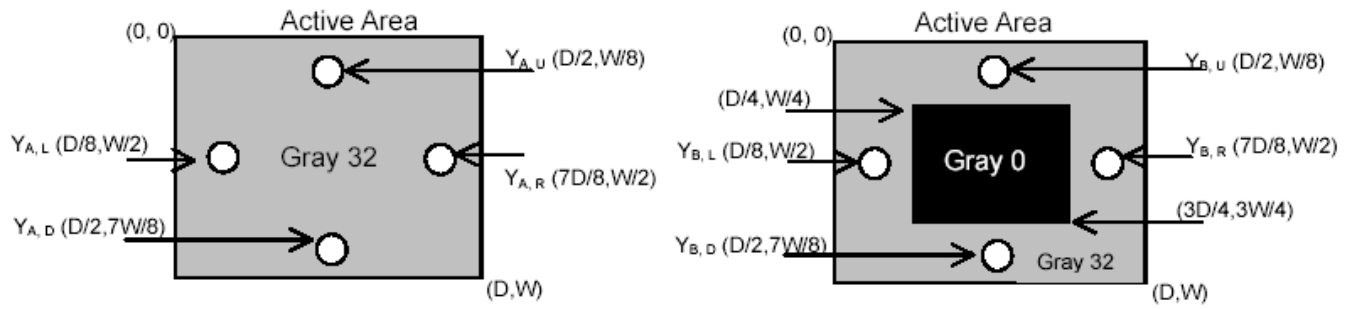

Note 8: Definition of response time:

The output signals of BM-7 or equivalent are measured when the input signals are changed from "Black" to "White" (falling time) and from "White" to "Black" (rising time), respectively. The response time interval between the 10% and 90% of amplitudes. Refer to figure as below.

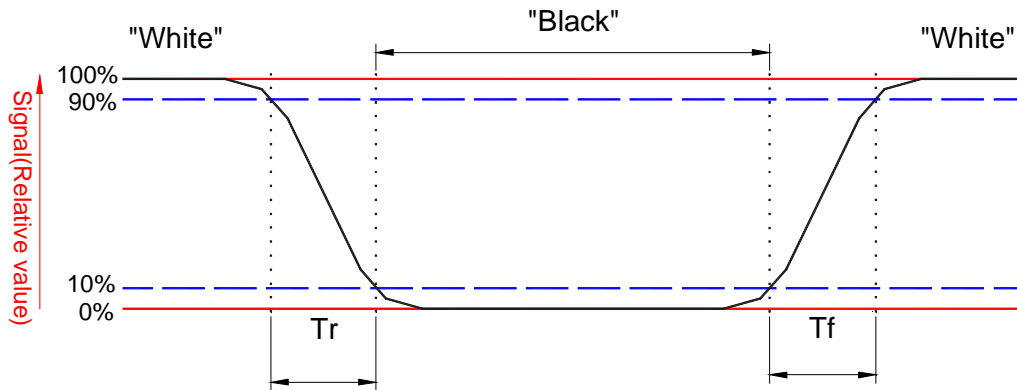

Note 9. Definition of viewing angle

Viewing angle is the measurement of contrast ratio ≥ 10 , at the screen center, over a 180° horizontal and 180° vertical range (off-normal viewing angles). The 180° viewing angle range is broken down as follows; 90° (θ) horizontal left and right and 90° (Φ) vertical, high (up) and low (down). The measurement direction is typically perpendicular to the display surface with the screen rotated about its center to develop the desired measurement viewing angle.

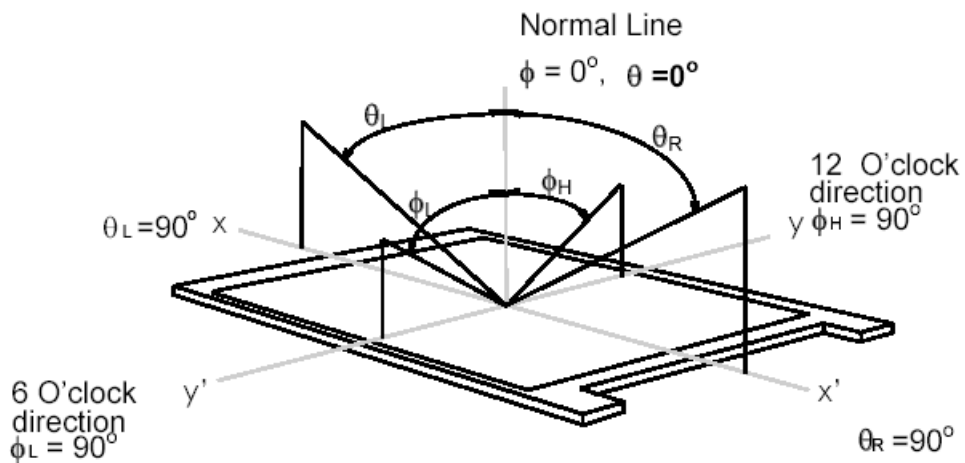

3. Functional Block Diagram

The following diagram shows the functional block of the 10.1 inches wide Color TFT/LCD 40 Pin (One CH/connector Module)

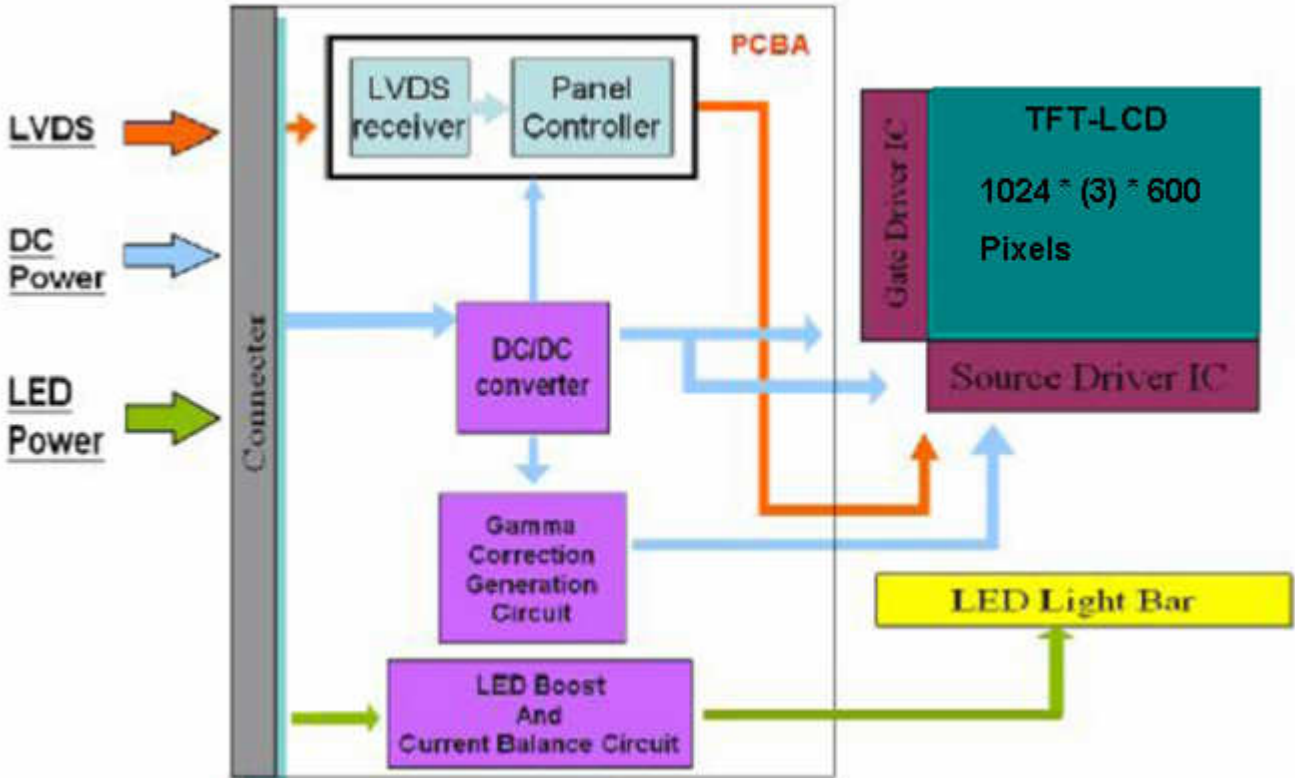

4. Absolute Maximum Ratings

An absolute maximum rating of the module is as following:

4.1 Absolute Ratings of TFT LCD Module

Item	Symbol	Min	Max	Unit	Conditions
Logic/LCD Drive	Vin	-0.3	+4.0	[Volt]	Note 1,2

4.2 Absolute Ratings of Environment

Item	Symbol	Min	Max	Unit	Conditions
Operating Temperature	TOP	0	+50	[°C]	Note 4
Operation Humidity	HOP	10	90	[%RH]	Note 4
Storage Temperature	TST	-20	+60	[°C]	Note 4
Storage Humidity	HST	10	90	[%RH]	Note 4

Note 1: At Ta (25°C)

Note 2: Permanent damage to the device may occur if exceed maximum values

Note 3: LED specification refer to section 5.2

Note 4: For quality performance, please refer to AUO IIS (Incoming Inspection Standard).

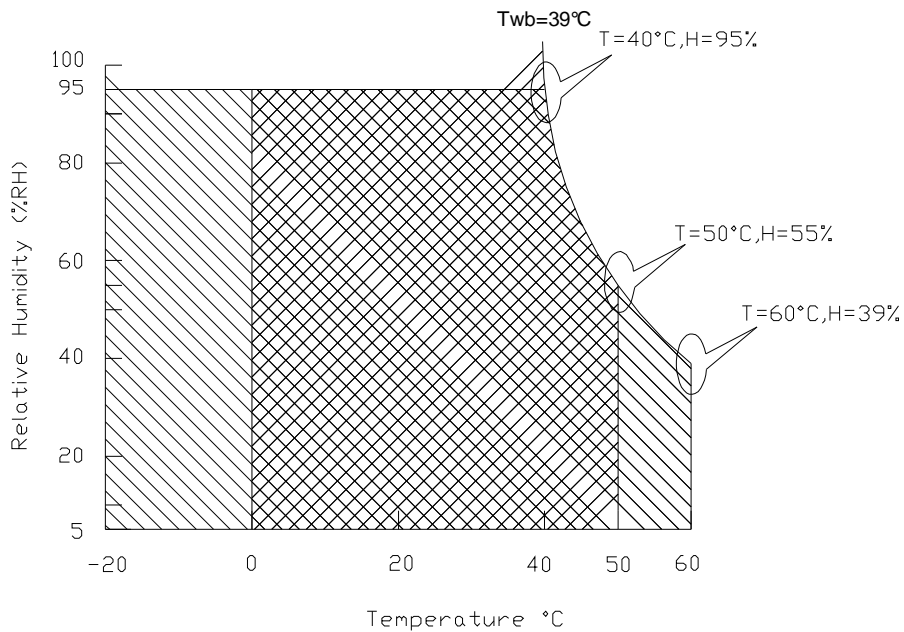

Operating Range 

Storage Range

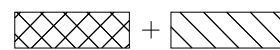

5. Electrical characteristics

5.1 TFT LCD Module

5.1.1 Power Specification

Input power specifications are as follows;

The power specification are measured under 25°C and frame frequency under 60Hz

Symble	Parameter	Min	Typ	Max	Units	Note
VDD	Logic/LCD Drive Voltage	3.0	3.3	3.6	[Volt]	
PDD	VDD Power	-	0.50	-	[Watt]	Note 1/2
IDD	IDD Current	-	150	-	[mA]	Note 1/2
IRush	Inrush Current	-	-	1500	[mA]	Note 3
VDDrp	Allowable Logic/LCD Drive Ripple Voltage	-	-	100	[mV] p-p	

Note 1 : Maximum Measurement Condition : Black Pattern

Note 2 : Typical Measurement Condition: Mosaic Pattern

Note 3 : Measure Condition

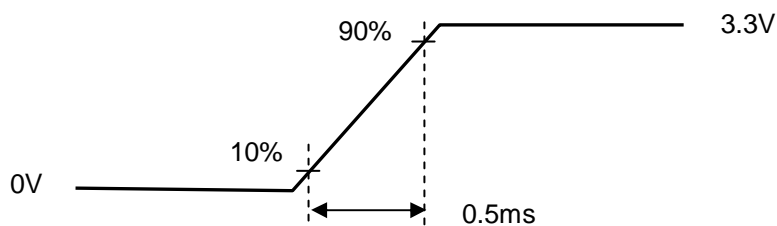
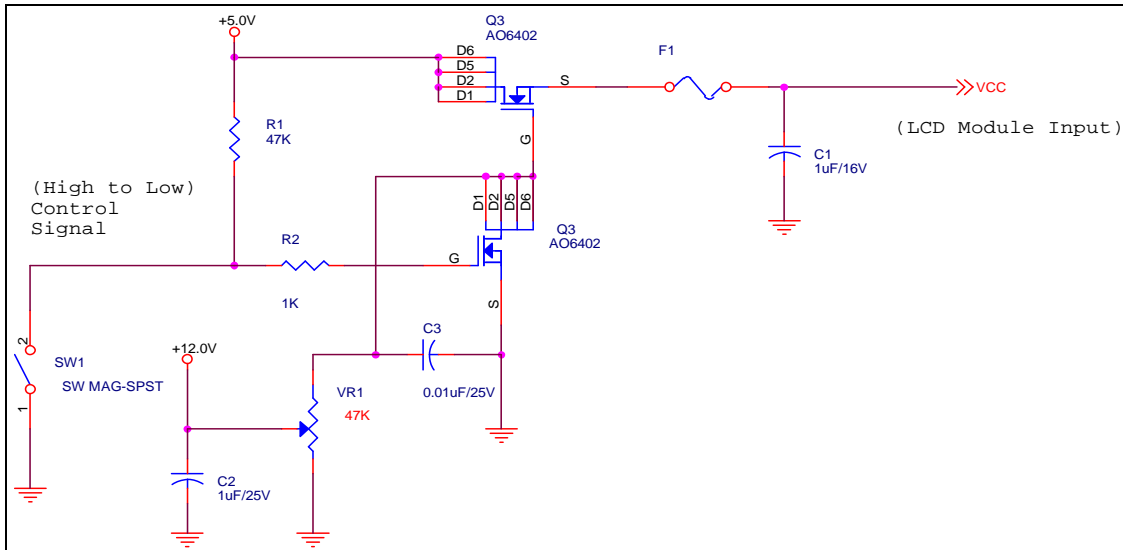

Vin rising time

5.1.2 Signal Electrical Characteristics:

Input signals shall be low or High-impedance state when VDD is off.

It is recommended to refer the specifications of SN75LVDS82DGG (Texas Instruments) in detail.

Signal electrical characteristics are as follows;

Parameter	Condition	Min	Max	Unit
Vth	Differential Input High Threshold (Vcm=+1.2V)	-	100	[mV]
Vtl	Differential Input Low Threshold (Vcm=+1.2V)	-100	-	[mV]
Vcm	Differential Input Common Mode Voltage	1.125	1.375	[V]

Note: LVDS Signal Waveform

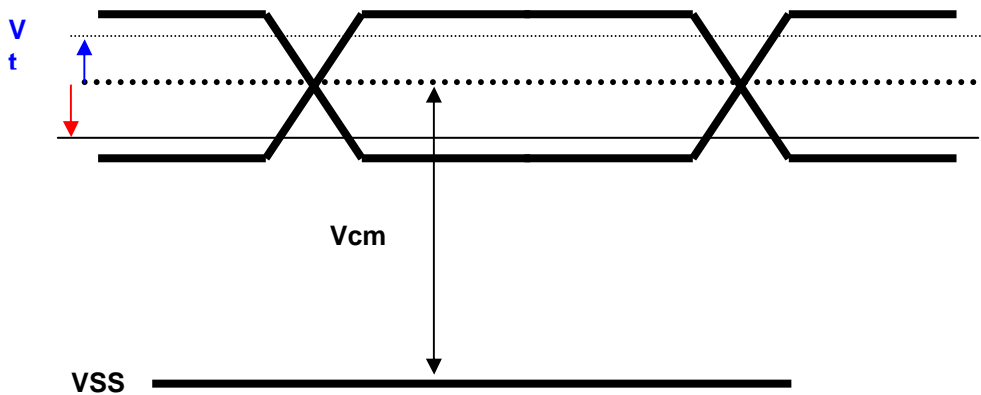



Product Specification

AU OPTRONICS CORPORATION

5.2 Backlight Unit

LED Parameter guideline for LED driving selection (Ref. Remark 1)

Parameter	Symbol	Min	Typ	Max	Units	Condition
LED Forward Voltage	V_F		4		[Volt]	($T_a=25^{\circ}\text{C}$)
LED Forward Current	I_F		20	30	[mA]	($T_a=25^{\circ}\text{C}$)
LED Power consumption	P_{LED}		2.16		[Watt]	($T_a=25^{\circ}\text{C}$) Note 1
LED Life-Time	N/A	10,000	-	-	Hour	($T_a=25^{\circ}\text{C}$) $I_F=20\text{ mA}$ Note 2
Output PWM frequency	F_{PWM}	100	200	20K	Hz	
Duty ratio	--	5	--	100	%	

Note 1: Calculator value for reference $I_F \times V_F = P$

Note 2: The LED life-time define as the estimated time to 50% degradation of initial luminous.

Note 3: This panel will support lower duty ration at PWM conditional frequency. The PWM frequency constrain between 100Hz to 300Hz and a same typical 200Hz. The duty ration will support from 5% to 100%

6. Signal Characteristic

6.1 Pixel Format Image

Following figure shows the relationship of the input signals and LCD pixel format.

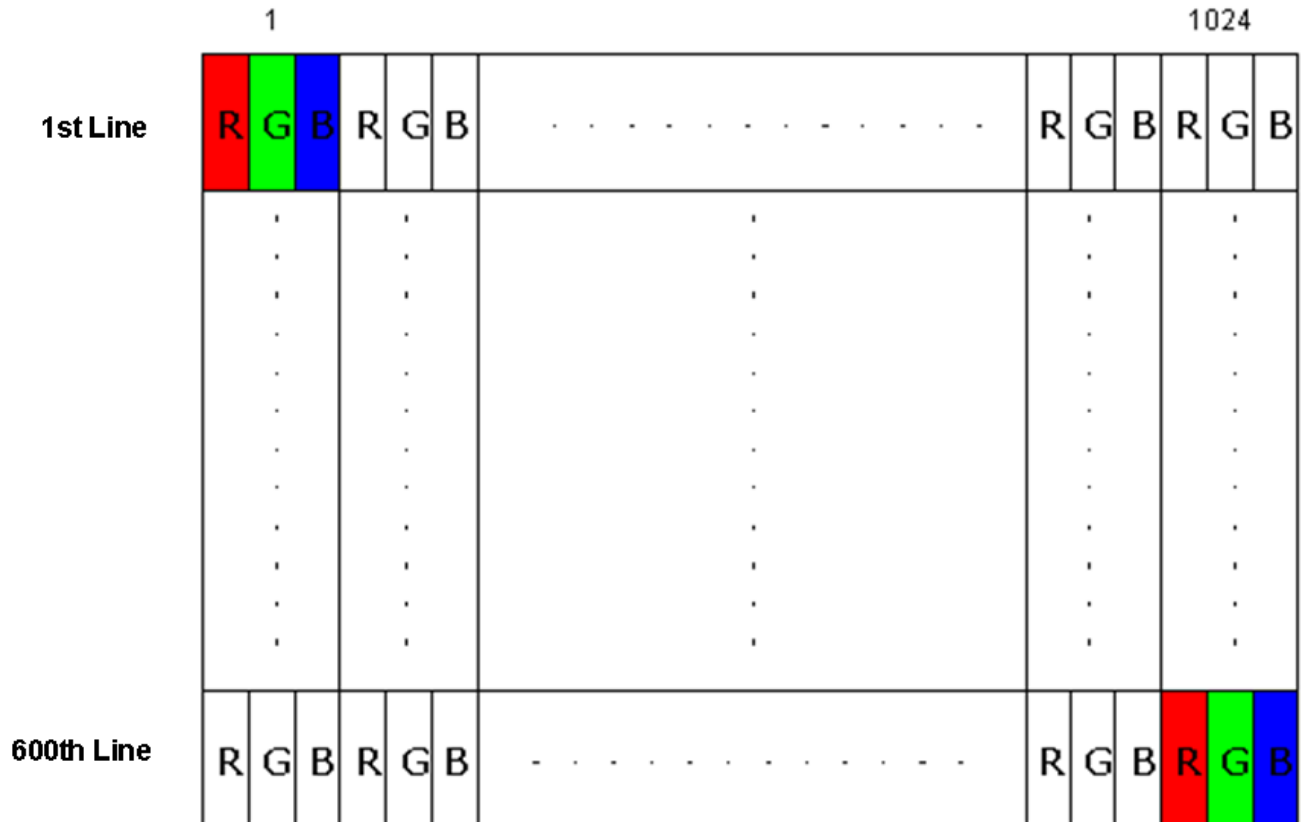

6.2 The input data format: TBD

Note: Output signals from any system shall be low or High-impedance state when VDD is off.

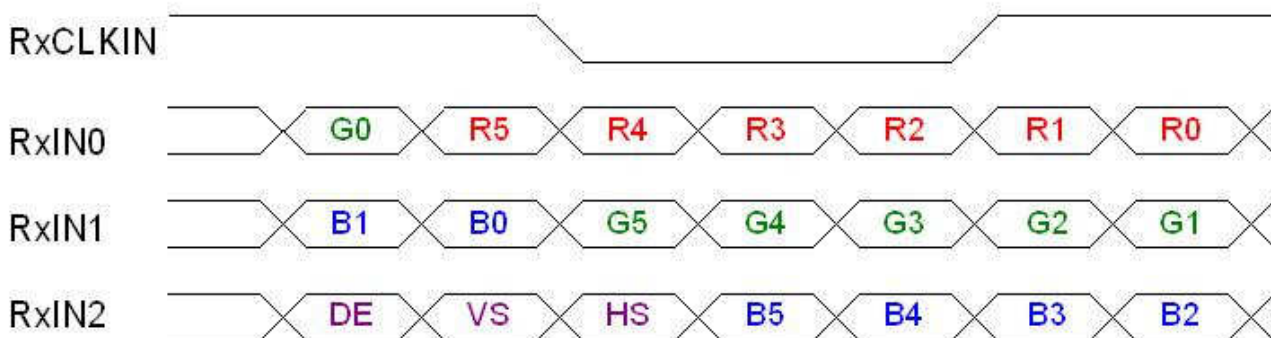



Product Specification

AU OPTRONICS CORPORATION

Signal Name	Description	
R5 R4 R3 R2 R1 R0	Red Data 5 (MSB) Red Data 4 Red Data 3 Red Data 2 Red Data 1 Red Data 0 (LSB) Red-pixel Data	Red-pixel Data Each red pixel's brightness data consists of these 6 bits pixel data.
G5 G4 G3 G2 G1 G0	Green Data 5 (MSB) Green Data 4 Green Data 3 Green Data 2 Green Data 1 Green Data 0 (LSB) Green-pixel Data	Green-pixel Data Each green pixel's brightness data consists of these 6 bits pixel data.
B5 B4 B3 B2 B1 B0	Blue Data 5 (MSB) Blue Data 4 Blue Data 3 Blue Data 2 Blue Data 1 Blue Data 0 (LSB) Blue-pixel Data	Blue-pixel Data Each blue pixel's brightness data consists of these 6 bits pixel data.
RxCLKIN	Data Clock	The typical frequency is 54.2MHZ.The signal is used to strobe the pixel data and DE signals. All pixel data shall be valid at the falling edge when the DE signal is high.
DE	Display Timing	This signal is strobed at the falling edge of RxCLKIN. When the signal is high, the pixel data shall be valid to be displayed.
VS	Vertical Sync	The signal is synchronized to RxCLKIN .
HS	Horizontal Sync	The signal is synchronized to RxCLKIN .

Note: Output signals from any system shall be low or High-impedance state when VDD is off.

6.3 Integration Interface and Pin Assignment: TBD

Pin	Signal	Description	Pin	Signal	Description
1	NC	No Connection	21	NC	No Connection (Reserve)
2	AVDD	PowerSupply,3.3V(typical)	22	GND	Ground
3	AVDD	PowerSupply,3.3V(typical)	23	NC	No Connection (Reserve)
4	DVDD	DDC 3.3Vpower	24	NC	No Connection (Reserve)
5	NC	No Connection (Reserve)	25	GND	Ground - Shield
6	SCL	DDCClock	26	NC	No Connection (Reserve)
7	SDA	DDCData	27	NC	No Connection (Reserve)
8	Rin0-	-LVDS differential data input(R0-R5,G0)	28	GND	Ground - Shield
9	Rin0+	+LVDS differential data input(R0-R5,G0)	29	NC	No Connection (Reserve)
10	GND	Ground	30	NC	No Connection (Reserve)
11	Rin1-	-LVDS differential data input(G1-G5,B0-B1)	31	VLED_GND	LED Ground
12	Rin1+	+LVDS differential data input(G1-G5,B0-B1)	32	VLED_GND	LED Ground
13	GND	Ground	33	VLED_GND	LED Ground
14	Rin2-	-LVDS differential data input(B2-B5,HS,VS,DE)	34	NC	No Connection (Reserve)
15	Rin2+	+LVDS differential data input(B2-B5,HS,VS,DE)	35	PWM	System PWM Signal Input
16	GND	Ground	36	LED_EN	LED enable pin(+3V Input)
17	ClkIN-	-LVDS differential clock input	37	NC	No Connection (Reserve)
18	ClkIN+	+LVDS differential clock input	38	VLED	LED Power Supply 5V~21V
19	GND	Ground	39	VLED	LED Power Supply 5V~21V
20	NC	NC	40	VLED	LED Power Supply 5V~21V

6.4 Interface Timing

6.4.1 Timing Characteristics

Basically, interface timings should match the 1024 x 600 /60Hz manufacturing guide line timing.

Parameter	Symbol	Min.	Typ.	Max.	Unit
Frame Rate	-		60		Hz
Clock frequency	$1/ T_{\text{Clock}}$		49.5		MHz
Vertical Section	Period	T_V	614		T_{Line}
	Active	T_{VD}	576		
	Blanking	T_{VB}	38		
Horizontal Section	Period	T_H	1344		T_{Clock}
	Active	T_{HD}	1024		
	Blanking	T_{HB}	320		

Note : DE mode only

6.4.2 Timing diagram

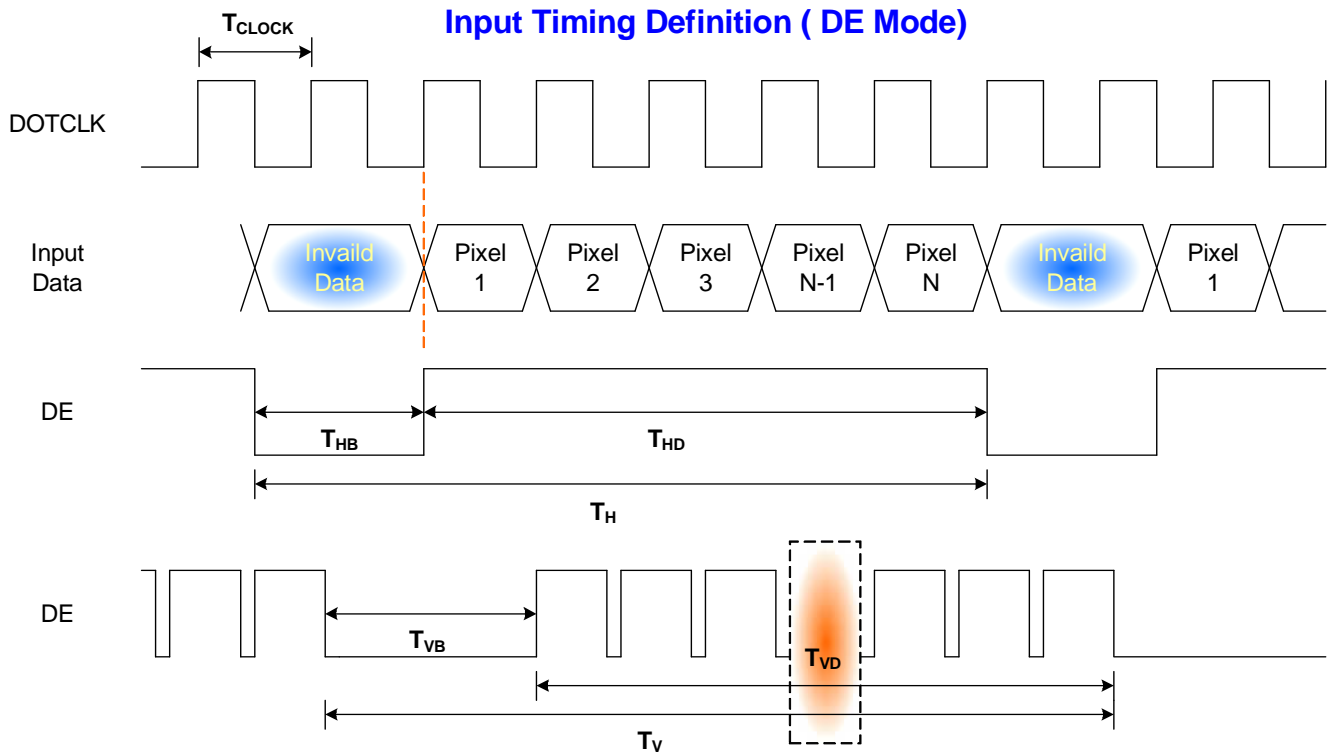

6.5 Power ON/OFF Sequence:

6.5.1 Panel Power Sequence

VDD power and LED on/off sequence is as follows. Interface signals are also shown in the chart. Signals from any system shall be Hi-Z state or low level when VDD is off.

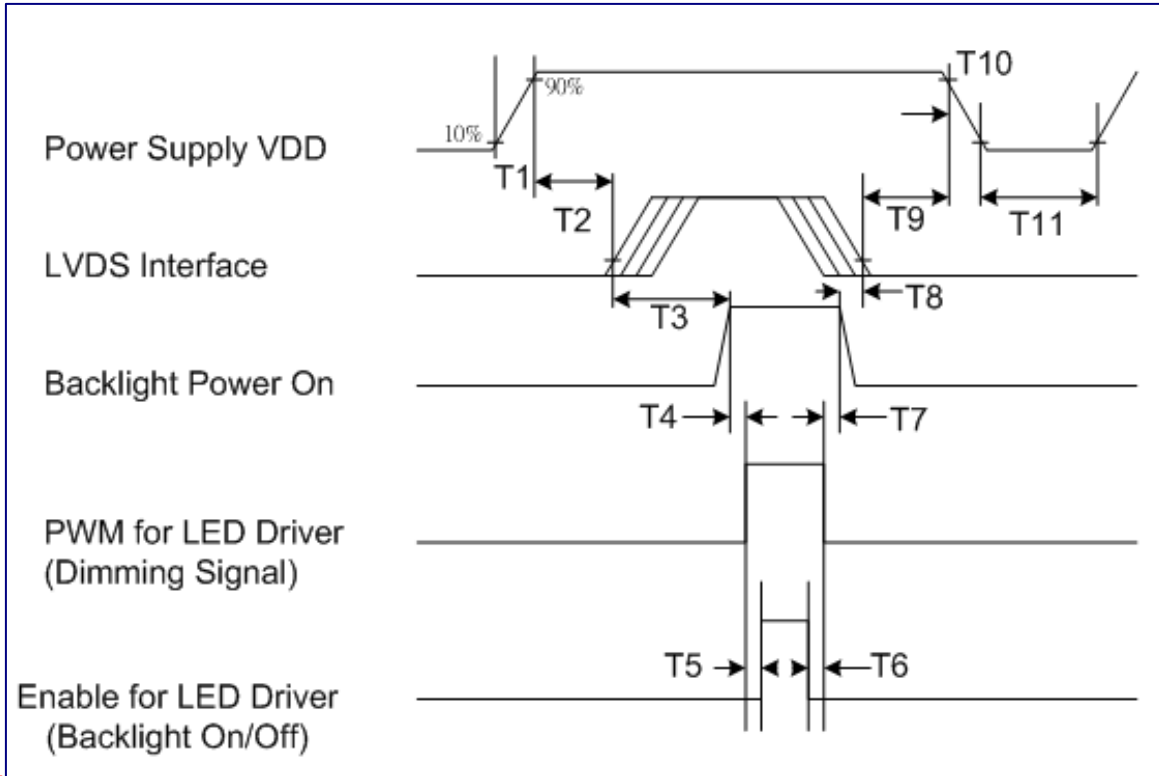

Parameter	Value			Unit
	Min.	Typ.	Max.	
T1	0.5	-	10	[ms]
T2	30	40	50	[ms]
T3	200	-	-	[ms]
T4	10	-	-	[ms]
T5	10	-	-	[ms]
T6	0	-	-	[ms]
T7	10	-	-	[ms]
T8	100	-	-	[ms]
T9	0	16	50	[ms]
T10	-	-	10	[ms]
T11	1000	-	-	[ms]

7. Connector Description

Physical interface is described as for the connector on module.

These connectors are capable of accommodating the following signals and will be following components.

7.1 TFT LCD Module

Connector Name / Designation	For Signal Connector
Manufacturer	IPEX / IPEX compatible
Type / Part Number	IPEX 20455-040E-12
Mating Housing/Part Number	IPEX 20453-040T-11



8. LED Driving Specification

8.1 Connector Description

It is a integrative interface and comibe into LVDS connector. The type and mating refer to section 7.

8.2 Pin Assignment

Ref. to 6.3



9. Vibration and Shock Test

9.1 Vibration Test

Test Spec:

- Test method: Non-Operation
- Acceleration: 1.5 G
- Frequency: 10 - 500Hz Random
- Sweep: 30 Minutes each Axis (X, Y, Z)

9.2 Shock Test Spec:

Test Spec:

- Test method: Non-Operation
- Acceleration: 220 G , Half sine wave
- Active time: 2 ms
- Pulse: X,Y,Z .one time for each side



10. Reliability

Items	Required Condition	Note
Temperature Humidity Bias	Ta= 40°C , 90%RH, 300h	
High Temperature Operation	Ta= 50°C , Dry, 300h	
Low Temperature Operation	Ta= 0°C , 300h	
High Temperature Storage	Ta= 60°C , 35%RH, 300h	
Low Temperature Storage	Ta= -20°C , 50%RH, 250h	
Thermal Shock Test	Ta=-20°C to 60°C , Duration at 30 min, 100 cycles	
ESD	Contact : ±8 KV Air : ±15 KV	Note 1

Note1: According to EN 61000-4-2 , ESD class B: Some performance degradation allowed. No data lost
. Self-recoverable. No hardware failures.

Remark: MTBF (Excluding the LED): 30,000 hours with a confidence level 90%



Product Specification

AU OPTRONICS CORPORATION

11. Mechanical Characteristics

11.1 LCM Outline Dimension:

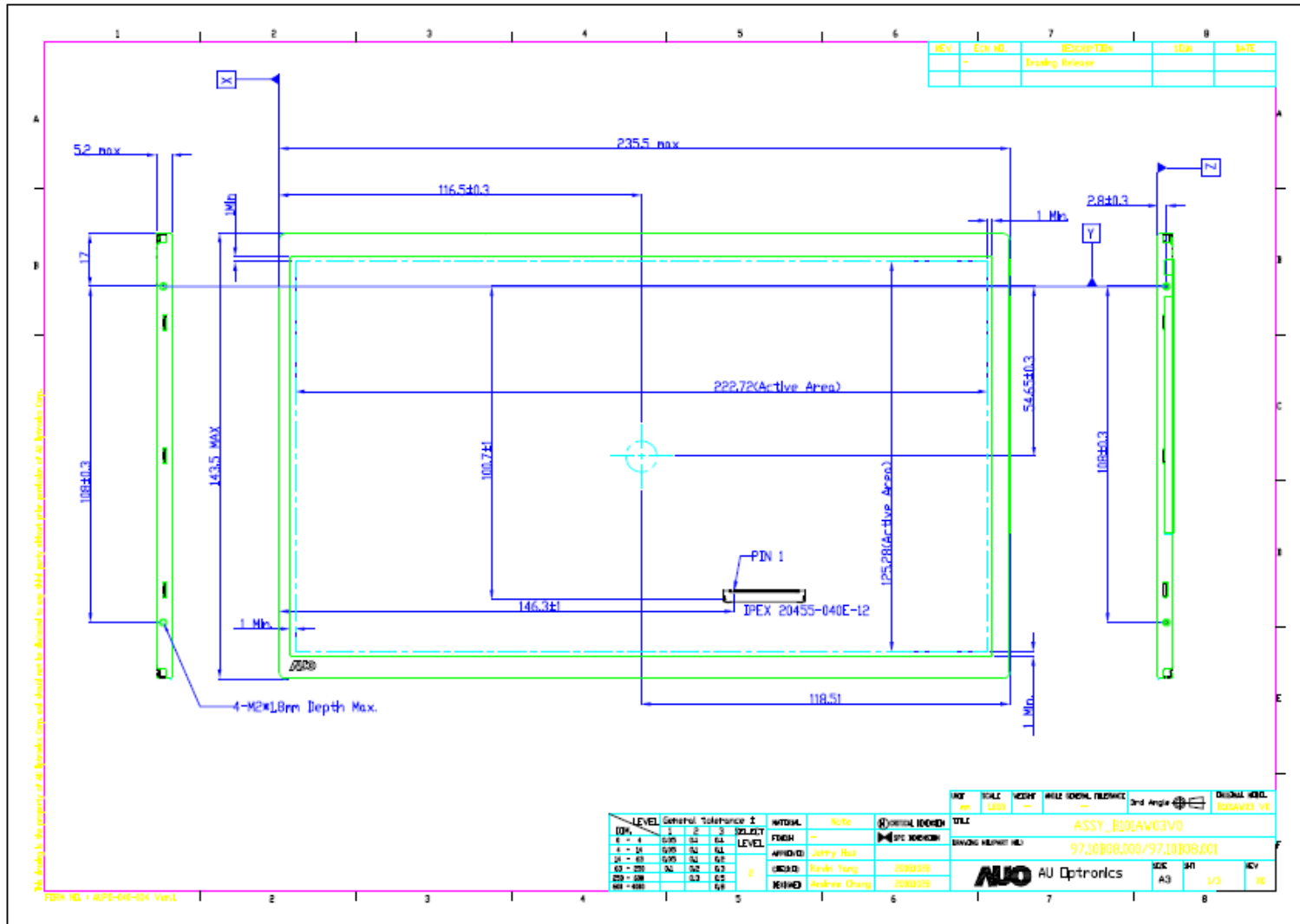



Product Specification

AU OPTRONICS CORPORATION

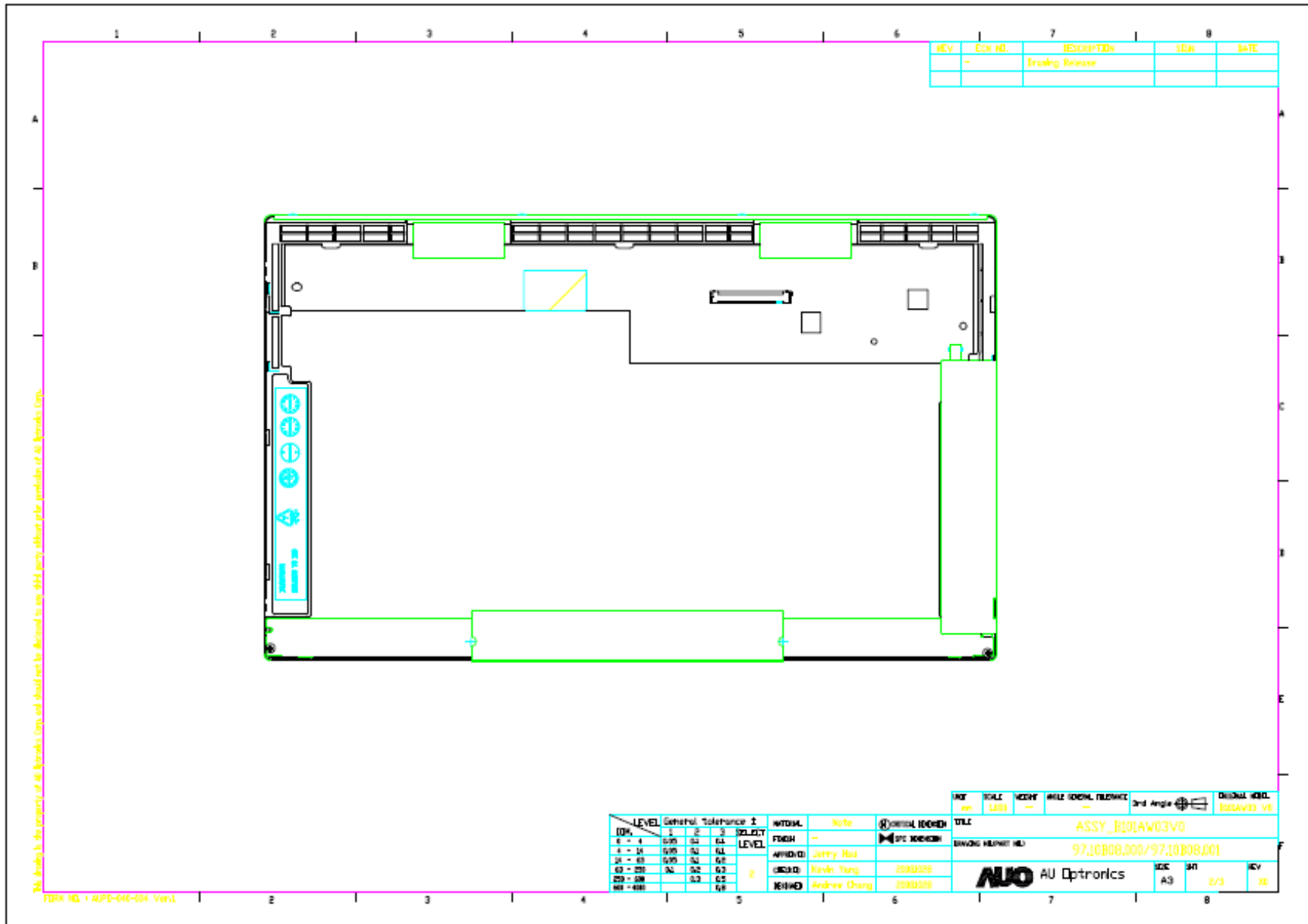

11.2 Screw Hole Depth and Center Position:

Screw hole maximum depth, from side surface = 2.0 mm (See drawing)

Screw hole center location, from front surface = 2.8 ± 0.3 mm (See drawing)

Screw Torque: Maximum 2.5 kgf-cm

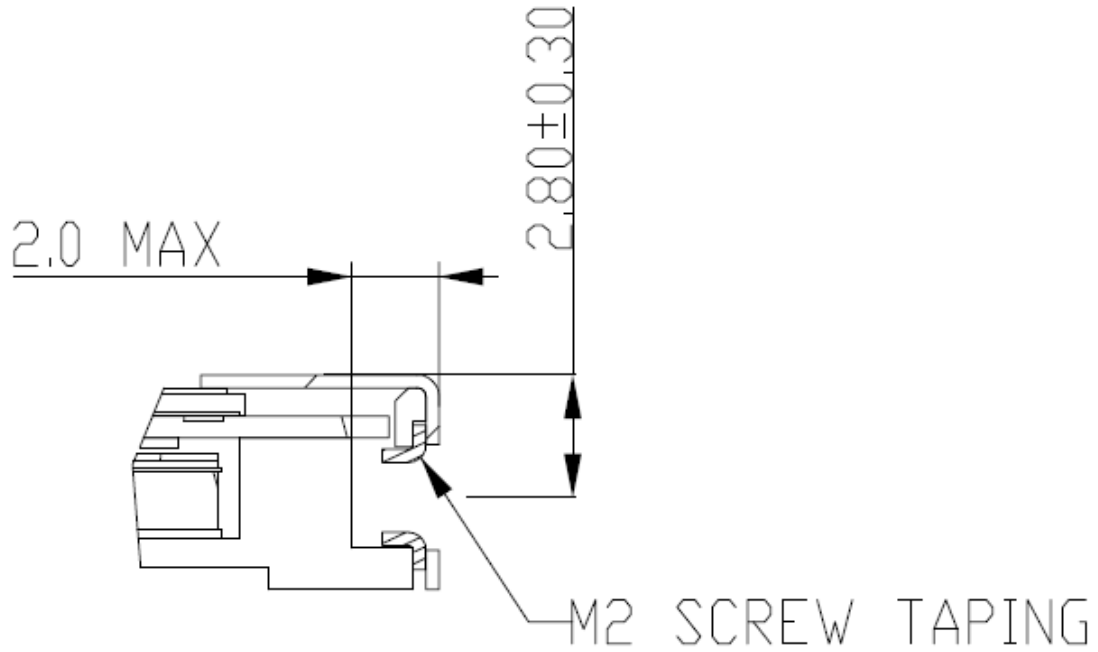



Product Specification

AU OPTRONICS CORPORATION

12. Shipping and Package

12.1 Shipping Label Format:



Manufactured **MM/WW**
Model No: **B101AW03 V0**
AU Optronics
MADE IN CHINA (S01)
HW: 1A FW:1

12.2 Carton package:

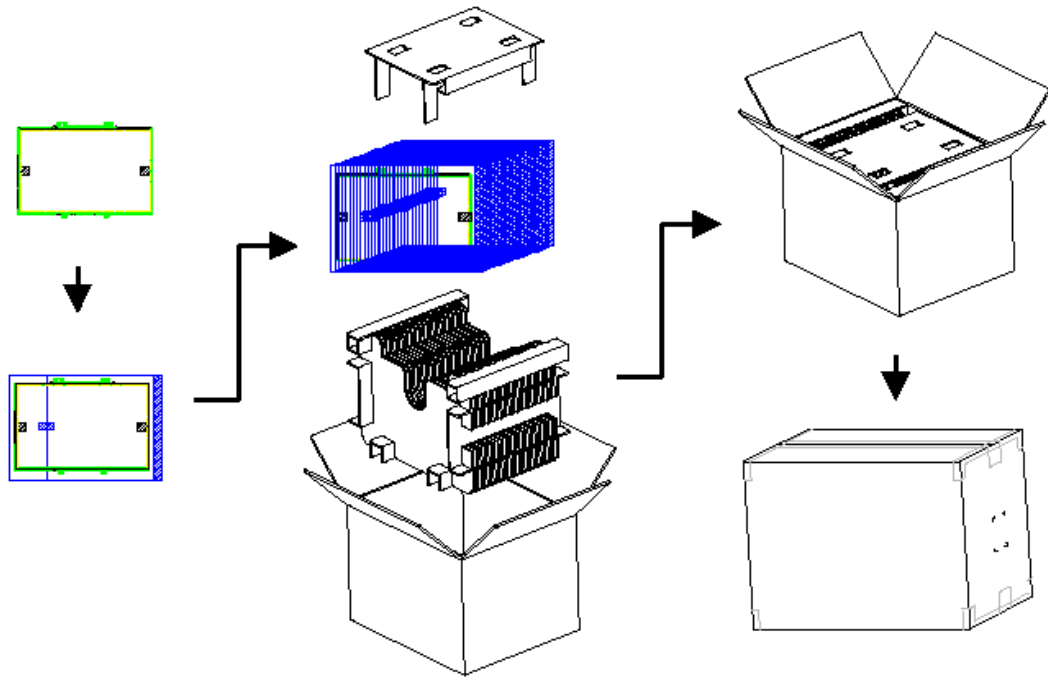

12.3 Shipping package of palletizing sequence:

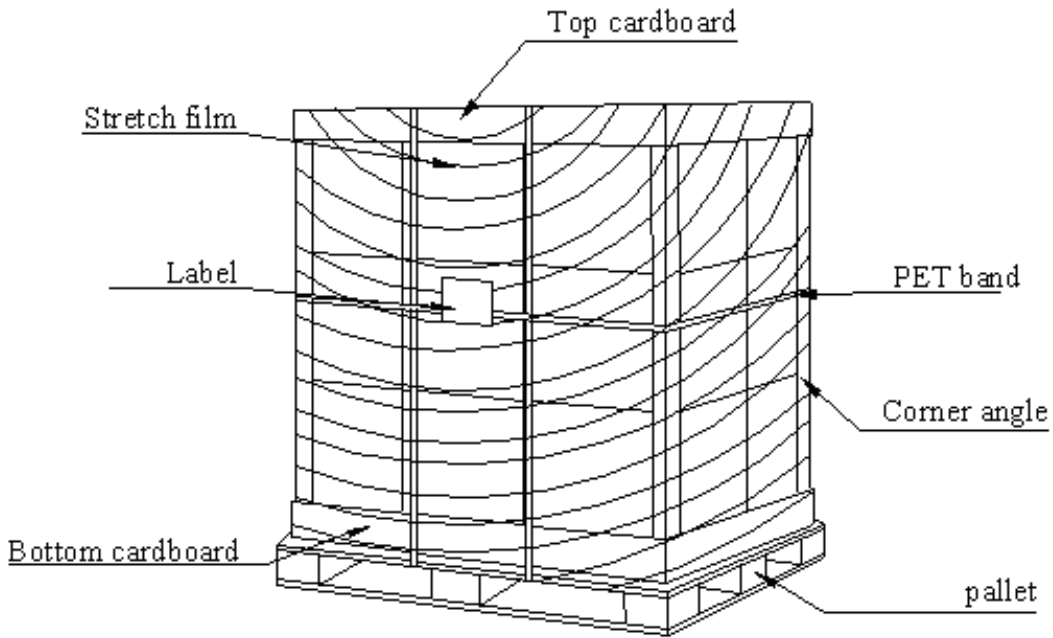



Product Specification

AU OPTRONICS CORPORATION

13. Appendix: EDID description

B101AW03 V0 EDID Code					
Address	FUNCTION	Value	Value	Value	Note
HEX		HEX	BIN	DEC	
00	Header	00	00000000	0	
01		FF	11111111	255	
02		FF	11111111	255	
03		FF	11111111	255	
04		FF	11111111	255	
05		FF	11111111	255	
06		FF	11111111	255	
07		00	00000000	0	
08	EISA Manuf. Code LSB	06	00000110	6	
09	Compressed ASCII	AF	10101111	175	
0A	Product Code	D2	11010010	210	
0B	hex, LSB first	30	00110000	48	
0C	32-bit ser #	00	00000000	0	
0D		00	00000000	0	
0E		00	00000000	0	
0F		00	00000000	0	
10	Week of manufacture	01	00000001	1	
11	Year of manufacture	12	00010010	18	
12	EDID Structure Ver.	01	00000001	1	
13	EDID revision #	03	00000011	3	
14	Video input def. (digital I/P, non-TMDS, CRGB)	80	10000000	128	
15	Max H image size (rounded to cm)	16	00010110	22	
16	Max V image size (rounded to cm)	0D	00001101	13	
17	Display Gamma (=gamma*100)-100)	78	01111000	120	
18	Feature support (no DPMS, Active OFF, RGB, tmg Blk#1)	0A	00001010	10	
19	Red/green low bits (Lower 2:2:2:2 bits)	11	00010001	17	
1A	Blue/white low bits (Lower 2:2:2:2 bits)	B5	10110101	181	
1B	Red x (Upper 8 bits)	97	10010111	151	
1C	Red y/ highER 8 bits	58	01011000	88	
1D	Green x	57	01010111	87	
1E	Green y	93	10010011	147	
1F	Blue x	26	00100110	38	
20	Blue y	1E	00011110	30	
21	White x	50	01010000	80	
22	White y	54	01010100	84	
23	Established timing 1	00	00000000	0	
24	Established timing 2	00	00000000	0	
25	Established timing 3	00	00000000	0	
26	Standard timing #1	01	00000001	1	
27		01	00000001	1	
28	Standard timing #2	01	00000001	1	
29		01	00000001	1	
2A	Standard timing #3	01	00000001	1	
2B		01	00000001	1	
2C	Standard timing #4	01	00000001	1	
2D		01	00000001	1	
2E	Standard timing #5	01	00000001	1	



Product Specification

AU OPTRONICS CORPORATION

2F		01	00000001	1	
30	Standard timing #6	01	00000001	1	
31		01	00000001	1	
32	Standard timing #7	01	00000001	1	
33		01	00000001	1	
34	Standard timing #8	01	00000001	1	
35		01	00000001	1	
36	Pixel Clock/10000 LSB	B0	10110000	176	
37	Pixel Clock/10000 USB	13	00010011	19	
38	Horz active Lower 8bits	00	00000000	0	
39	Horz blanking Lower 8bits	40	01000000	64	
3A	HorzAct:HorzBlnk Upper 4:4 bits	41	01000001	65	
3B	Vertical Active Lower 8bits	58	01011000	88	
3C	Vertical Blanking Lower 8bits	19	00011001	25	
3D	Vert Act : Vertical Blanking (upper 4:4 bit)	20	00100000	32	
3E	HorzSync. Offset	18	00011000	24	
3F	HorzSync.Width	88	10001000	136	
40	VertSync.Offset : VertSync.Width	31	00110001	49	
41	Horz&Vert Sync Offset/Width Upper 2bits	00	00000000	0	
42	Horizontal Image Size Lower 8bits	DF	11011111	223	
43	Vertical Image Size Lower 8bits	7D	01111101	125	
44	Horizontal & Vertical Image Size (upper 4:4 bits)	00	00000000	0	
45	Horizontal Border (zero for internal LCD)	00	00000000	0	
46	Vertical Border (zero for internal LCD)	00	00000000	0	
47	Signal (non-intr, norm, no stereo, sep sync, neg pol)	18	00011000	24	
48	Detailed timing/monitor	00	00000000	0	
49	descriptor #2	00	00000000	0	
4A		00	00000000	0	
4B		0F	00001111	15	
4C		00	00000000	0	
4D		00	00000000	0	
4E		00	00000000	0	
4F		00	00000000	0	
50		00	00000000	0	
51		00	00000000	0	
52		00	00000000	0	
53		00	00000000	0	
54		00	00000000	0	
55		00	00000000	0	
56		00	00000000	0	
57		00	00000000	0	
58		00	00000000	0	
59		20	00100000	32	
5A	Detailed timing/monitor	00	00000000	0	
5B	descriptor #3	00	00000000	0	
5C		00	00000000	0	
5D		FE	11111110	254	
5E		00	00000000	0	
5F	Manufacture	41	01000001	65	A
60	Manufacture	55	01010101	85	U
61	Manufacture	4F	01001111	79	O
62		0A	00001010	10	



Product Specification

AU OPTRONICS CORPORATION

63		20	00100000	32	
64		20	00100000	32	
65		20	00100000	32	
66		20	00100000	32	
67		20	00100000	32	
68		20	00100000	32	
69		20	00100000	32	
6A		20	00100000	32	
6B		20	00100000	32	
6C	Detailed timing/monitor	00	00000000	0	
6D	descriptor #4	00	00000000	0	
6E		00	00000000	0	
6F		FE	11111110	254	
70		00	00000000	0	
71	Manufacture P/N	42	01000010	66	B
72	Manufacture P/N	31	00110001	49	1
73	Manufacture P/N	30	00110000	48	0
74	Manufacture P/N	31	00110001	49	1
75	Manufacture P/N	41	01000001	65	A
76	Manufacture P/N	57	01010111	87	W
77	Manufacture P/N	30	00110000	48	0
78	Manufacture P/N	33	00110011	51	3
79	Manufacture P/N	20	00100000	32	
7A	Manufacture P/N	56	01010110	86	V
7B	Manufacture P/N	30	00110000	48	0
7C		20	00100000	32	
7D		0A	00001010	10	
7E	Extension Flag	00	00000000	0	
7F	Checksum	89	10001001	137	
			SUM	6144	

SUM to HEX 1800