

mass integrated

global part distribution • product lifecycle partner
excess inventory management • value-ad service provider



Data sheet provided by Mass Integrated

massintegrated.com • displayalliance.com

Please call +1.978.465.6190
Email: sales@massintegrated.com



ISO 9001: 2008

Mass Integrated complies with all DMCA takedown notices. Please send a formal DMCA Takedown Notice to Mass Integrated Systems, Inc. • 18 Henry Graf Jr. Road, Unit 1 • Newburyport, MA 01950.



Product Specification

AU OPTRONICS CORPORATION

(V) Preliminary Specifications

() Final Specifications

Module	” WXGA Color TFT-LCD with LED Backlight design
Model Name	B121EW09 V2
Note ()	LED Backlight with driving circuit design

Customer	Date
<u>HP</u>	
Checked & Approved by	Date
_____	_____
<p>Note: This Specification is subject to change without notice.</p>	

Approved by	Date
<u>Jerry Chen</u>	<u>08/12/2008</u>
Prepared by	
<u>Kevin Shen</u>	<u>08/12/2008</u>
<p>NBBU Marketing Division / AU Optronics corporation</p>	



Product Specification

AU OPTRONICS CORPORATION

Contents

1. Handling Precautions	5
2. General Description	6
2.1 General Specification	6
2.2 Optical Characteristics	7
3. Functional Block Diagram	12
4. Absolute Maximum Ratings.....	12
4. Absolute Maximum Ratings.....	13
4.1 Absolute Ratings of TFT LCD Module	13
4.2 Absolute Ratings of Backlight Unit.....	13
4.3 Absolute Ratings of Environment	13
5. Electrical characteristics	14
5.1 TFT LCD Module	14
5.2 Backlight Unit	16
6. Signal Characteristic	17
6.1 Pixel Format Image	17
6.2 The input data format	18
6.3 Signal Description/Pin Assignment.....	19
6.4 Interface Timing.....	22
6.5 LED Power Sequence	24
7. Connector Description	26
7.1 TFT LCD Module	26
8. LED Driving Specification	27
8.1 Connector Description.....	27
8.2 Pin Assignment	27
9. Vibration and Shock test	29
9.1 Vibration test	27
9.2 Shock test spec.....	27
10. Reliability	299
11. Mechanical Characteristics	30
11.1 LCM Outline Dimension.....	30
11.2 Screw Hole Depth and Center Position.....	32
12. Shipping and Package	33
12.1 Shipping Label Format	33
12.2 Carton package	34



Product Specification

AU OPTRONICS CORPORATION

12.3 Shipping package of palletizing sequence	34
13. Appendix: EDID description	35



Product Specification

AU OPTRONICS CORPORATION

Record of Revision

Version and Date	Page	Old description	New Description	Remark
0.1 2008/05/12	All	New version		
0.2 2008/08/12	7		Update LCM outline drawing	



1. Handling Precautions

- 1) Since front polarizer is easily damaged, pay attention not to scratch it.
- 2) Be sure to turn off power supply when inserting or disconnecting from input connector.
- 3) Wipe off water drop immediately. Long contact with water may cause discoloration or spots.
- 4) When the panel surface is soiled, wipe it with absorbent cotton or other soft cloth.
- 5) Since the panel is made of glass, it may break or crack if dropped or bumped on hard surface.
- 6) Since CMOS LSI is used in this module, take care of static electricity and insure human earth when handling.
- 7) Do not open nor modify the Module Assembly.
- 8) Do not press the reflector sheet at the back of the module to any directions.
- 9) At the insertion or removal of the Signal Interface Connector, be sure not to rotate nor tilt the Interface Connector of the TFT Module.
- 11) After installation of the TFT Module into an enclosure (Notebook PC Bezel, for example), do not twist nor bend the TFT Module even momentarily. At designing the enclosure, it should be taken into consideration that no bending/twisting forces are applied to the TFT Module from outside. Otherwise the TFT Module may be damaged.
- 12) Small amount of materials having no flammability grade is used in the LCD module. The LCD module should be supplied by power complied with requirements of Limited Power Source (IEC60950 or UL1950), or be applied exemption.
- 13) Disconnecting power supply before handling LCD modules, it can prevent electric shock, DO NOT TOUCH the electrode parts, cables, connectors and LED circuit part of TFT module that a LED light bar build in as a light source of back light unit. It can prevent electrostatic breakdown.



Product Specification

AU OPTRONICS CORPORATION

2. General Description

B121EW09 V2 is a Color Active Matrix Liquid Crystal Display composed of a TFT LCD panel, a driver circuit, and LED backlight system. The screen format is intended to support the WXGA (1280(H) x 800(V)) screen and 262k colors (RGB 6-bits data driver) with LED backlight driving circuit. All input signals are LVDS interface compatible.

B121EW09 V2 is designed for a display unit of notebook style personal computer and industrial machine.

2.1 General Specification

The following items are characteristics summary on the table at 25 °C condition:

Items	Unit	Specifications			
Screen Diagonal	[mm]	307.9 (W")			
Active Area	[mm]	261.12(H) X 163.20(V)			
Pixels H x V		1280x3(RGB) x 800			
Pixel Pitch	[mm]	0.204X0.204			
Pixel Arrangement		R.G.B. Vertical Stripe			
Display Mode		Normally White			
White Luminance (I _{LED} =20mA) Note: I _{LED} is LED current	[cd/m ²]	200 typ. (5 points average) 170 min. (5 points average) (Note1)			
Luminance Uniformity		1.25 max. (5 points)			
Contrast Ratio		500 typ			
Response Time	[ms]	16 typ / 25 Max			
Nominal Input Voltage VDD	[Volt]	+3.3 typ.			
Power Consumption	[Watt]	4.3 max. (Include Logic and Black Light power)			
Weight	[Grams]	270 max.			
Physical Size	[mm]		L	W	T
		Max	276.3	178.6	5.5
		Typical	275.8	178	-
		Min	275.3	-	-
Electrical Interface		1 channel LVDS			
Surface Treatment		Glare			



Product Specification

AU OPTRONICS CORPORATION

Support Color		262K colors (RGB 6-bit)
Temperature Range Operating Storage (Non-Operating)	[°C] [°C]	0 to +50 -20 to +65
RoHS Compliance		RoHS Compliance

2.2 Optical Characteristics

The optical characteristics are measured under stable conditions at 25°C (Room Temperature) :

Item	Unit	Conditions	Min.	Typ.	Max.	Note
White Luminance I _{LED} =20mA	[cd/m ²]	5 points average	170	200	-	1, 4, 5.
Viewing Angle	[degree] [degree]	Horizontal (Right) CR = 10 (Left)	30 30		- -	4,9
	[degree] [degree]	Vertical (Upper) CR = 10 (Lower)	10 20		- -	
Luminance Uniformity		5 Points	-	-	1.25	1,3,4
Luminance Uniformity		13 Points	-	-	1.50	2,3,4
CR: Contrast Ratio		DCR:Off	-	500	-	4,6
Cross talk	%				4	4,7
Response Time	[msec]	Rising	-	TBD	-	4,8
	[msec]	Falling	-	TBD	-	
	[msec]	Rising + Falling	-	16	25	
Chromaticity of color Coordinates (CIE 1931)		Red x	0.530	0.560	0.590	4,9
		Red y	0.320	0.350	0.380	
		Green x	0.315	0.345	0.375	
		Green y	0.530	0.560	0.590	
		Blue x	0.120	0.150	0.180	
		Blue y	0.075	0.105	0.135	
		White x	0.283	0.313	0.343	
	White y	0.299	0.329	0.359		

Note 1: 5 points position (Ref: Active area)

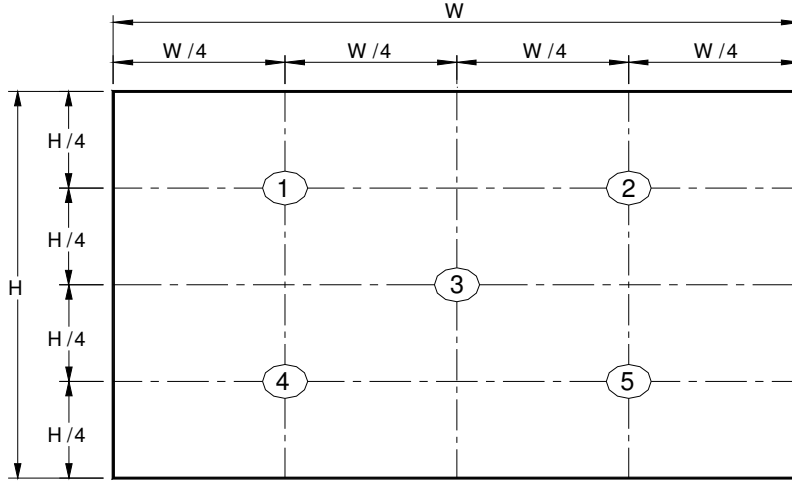

Note 2: 13 points position (Ref: Active area)

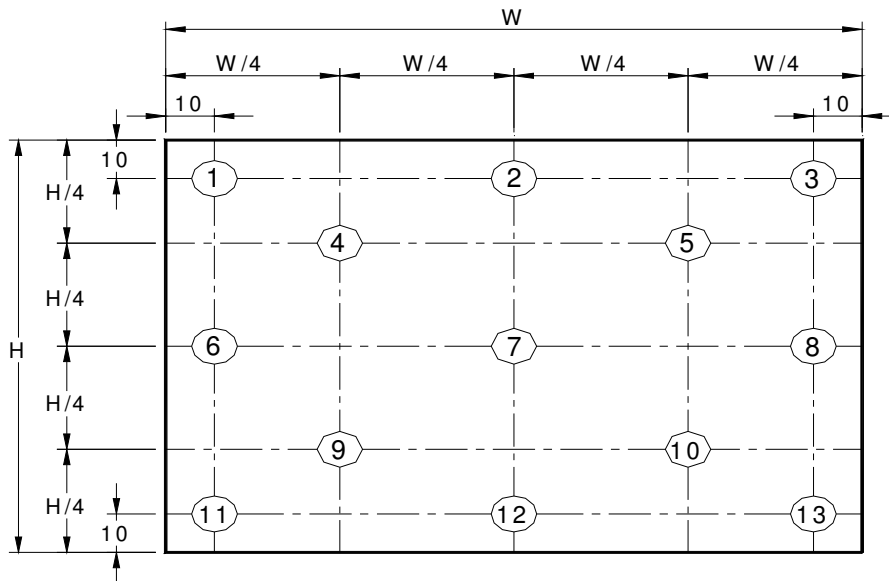

Note 3: The luminance uniformity of 5 or 13 points is defined by dividing the maximum luminance values by the minimum test point luminance

$$\delta_{W5} = \frac{\text{Maximum Brightness of five points}}{\text{Minimum Brightness of five points}}$$

$$\delta_{W13} = \frac{\text{Maximum Brightness of thirteen points}}{\text{Minimum Brightness of thirteen points}}$$

Note 4: Measurement method

The LCD module should be stabilized at given temperature for 30 minutes to avoid abrupt temperature change during measuring. In order to stabilize the luminance, the measurement should be executed after lighting Backlight for 30 minutes in a stable, windless and dark room.

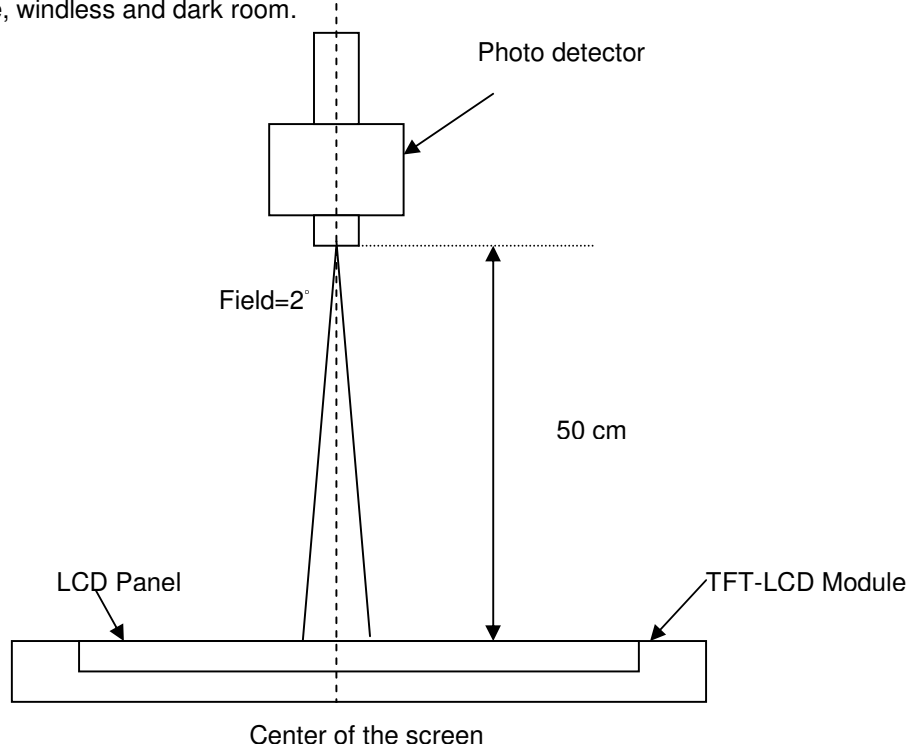

Note 5 : Definition of Average Luminance of White (Y_L):

Measure the luminance of gray level 63 at 5 points · $Y_L = [L (1)+ L (2)+ L (3)+ L (4)+ L (5)] / 5$

$L (x)$ is corresponding to the luminance of the point X at Figure in Note (1).

Note 6 : Definition of contrast ratio:

Contrast ratio is calculated with the following formula.

$$\text{Contrast ratio (CR)} = \frac{\text{Brightness on the "White" state}}{\text{Brightness on the "Black" state}}$$

Note 7 : Definition of Cross Talk (CT)

$$CT = |Y_B - Y_A| / Y_A \times 100 (\%)$$

Where

Y_A = Luminance of measured location without gray level 0 pattern (cd/m^2)

Y_B = Luminance of measured location with gray level 0 pattern (cd/m²)

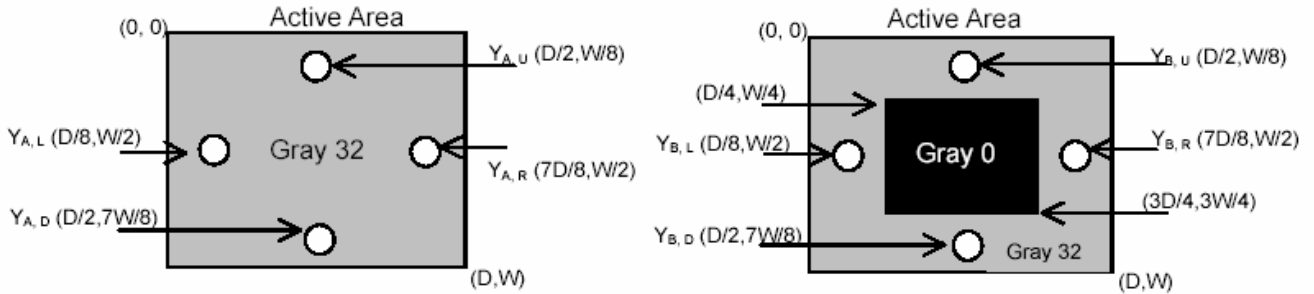

Note 8: Definition of response time:

The output signals of BM-7 or equivalent are measured when the input signals are changed from "Black" to "White" (falling time) and from "White" to "Black" (rising time), respectively. The response time interval between the 10% and 90% of amplitudes. Refer to figure as below.

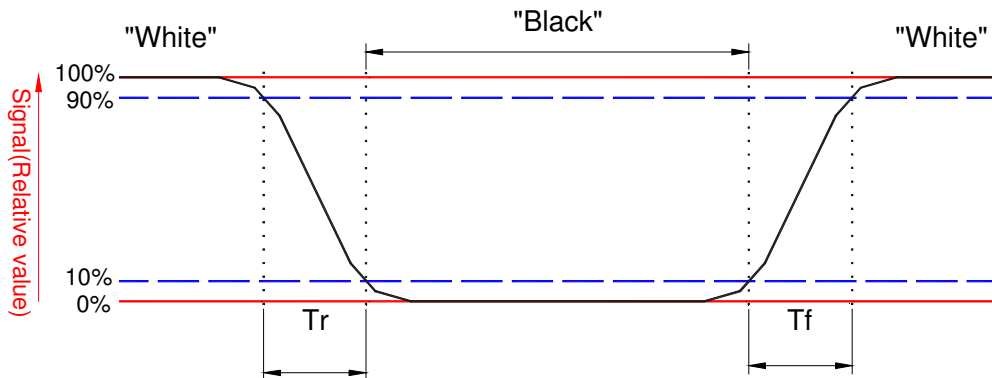

Note 8. Definition of viewing angle

Viewing angle is the measurement of contrast ratio ≥ 10 , at the screen center, over a 180° horizontal and 180° vertical range (off-normal viewing angles). The 180° viewing angle range is broken down as follows; 90° (θ) horizontal left and right and 90° (Φ) vertical, high (up) and low (down). The measurement direction is typically perpendicular to the display surface with the screen rotated about its center to develop the desired measurement viewing angle.

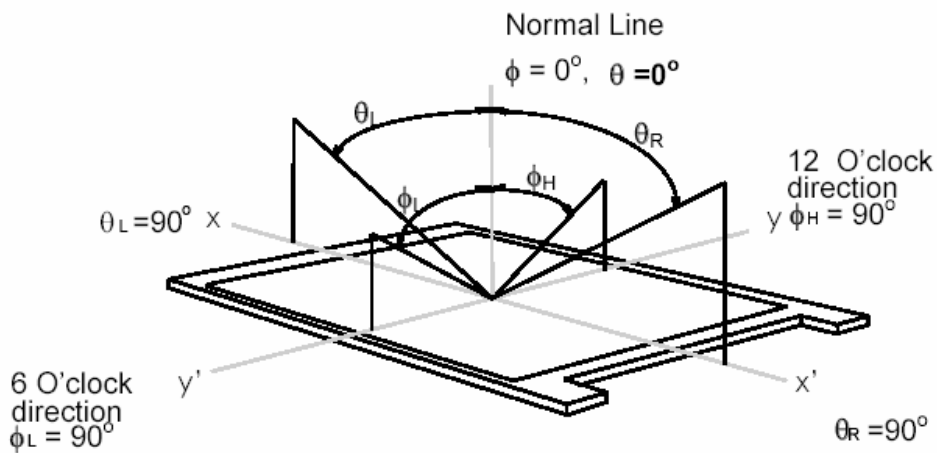

3. Functional Block Diagram

The following diagram shows the functional block of the 12.1 inches wide Color TFT/LCD 40 Pin (One ch/connector Module):

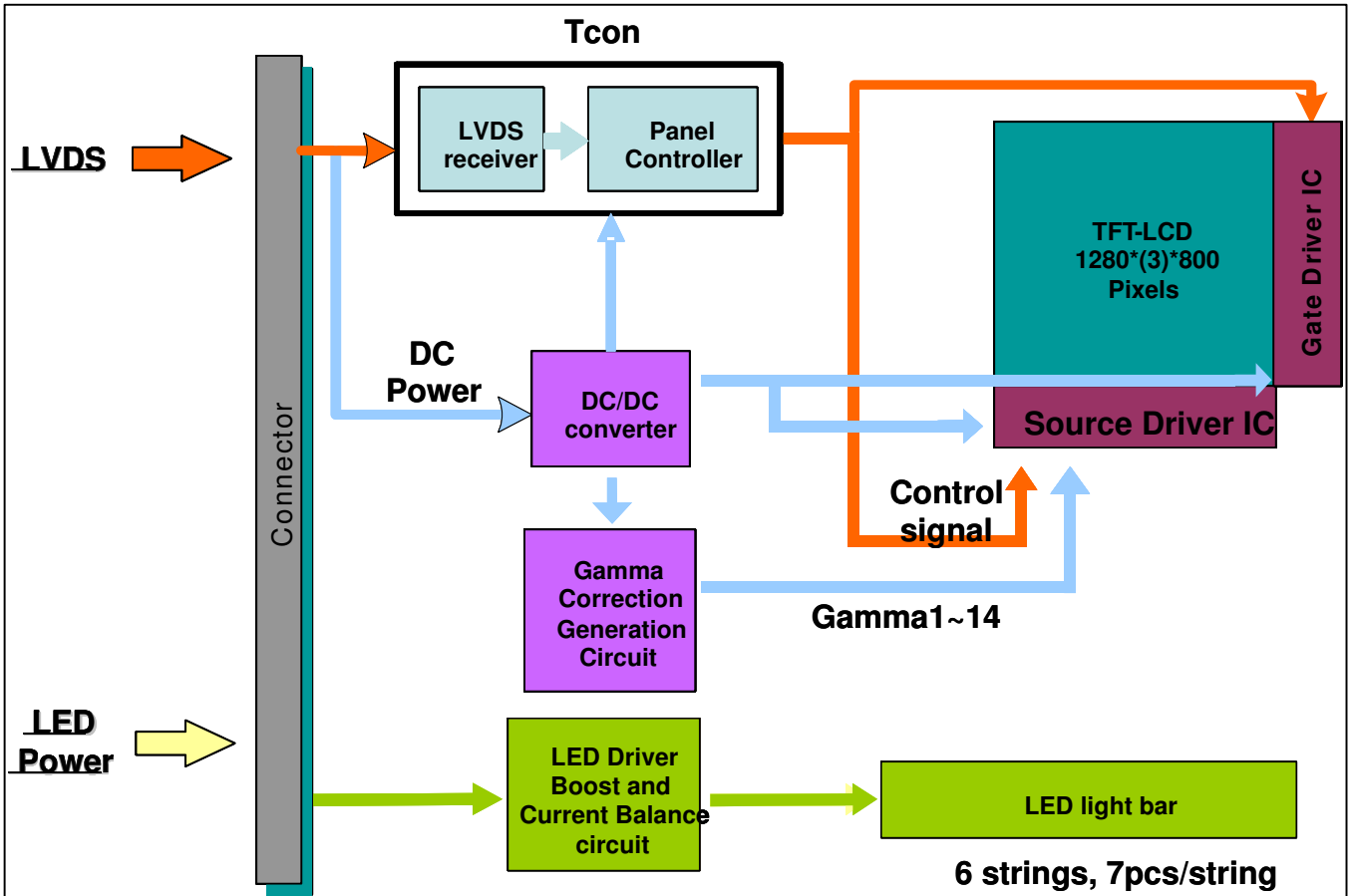

4. Absolute Maximum Ratings

An absolute maximum rating of the module is as following:

4.1 Absolute Ratings of TFT LCD Module

Item	Symbol	Min	Max	Unit	Conditions
Logic/LCD Drive Voltage	V _{in}	-0.3	+4.0	[Volt]	Note 1,2

4.2 Absolute Ratings of Backlight Unit

Item	Symbol	Min	Max	Unit	Conditions
LED Driving Voltage	V _{LED}	-	36 (Row Output)	[Volt]	Note 1,2,3
LED Driving Current	I _{LED}	-	30 (Row Output)	[mA] rms	Note 1,2,3

4.3 Absolute Ratings of Environment

Item	Symbol	Min	Max	Unit	Conditions
Operating Temperature	TOP	0	+50	[°C]	Note 4
Operation Humidity	HOP	8	95	[%RH]	Note 4
Storage Temperature	TST	-20	+65	[°C]	Note 4
Storage Humidity	HST	5	95	[%RH]	Note 4

Note 1: At Ta (25°C)

Note 2: Permanent damage to the device may occur if exceed maximum values

Note 3: LED specification refer to section 5.2

Note 4: For quality performance, please refer to AUO IIS (Incoming Inspection Standard).

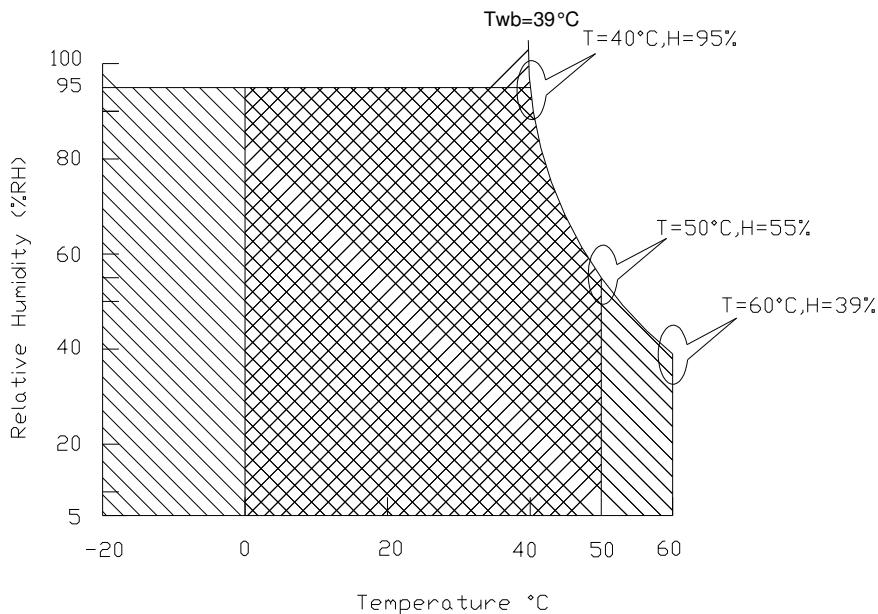

Operating Range 

Storage Range  + 

5. Electrical characteristics

5.1 TFT LCD Module

5.1.1 Power Specification

Input power specifications are as follows;

Symble	Parameter	Min	Typ	Max	Units	Note
VDD	Logic/LCD Drive Voltage	3.0	3.3	3.6	[Volt]	
PDD	VDD Power	-		0.9	[Watt]	Note 1/2
IDD	IDD Current	-	TBD	TBD	[mA]	Note 1/2
IRush	Inrush Current	-	-	2000	[mA]	Note 3
VDDrp	Allowable Logic/LCD Drive Ripple Voltage	-	-	TBD	[mV] p-p	

Note 1 : Maximum Measurement Condition : Black Pattern

Note 2 : Typical Measurement Condition: Mosaic Pattern

Note 3 : Measure Condition

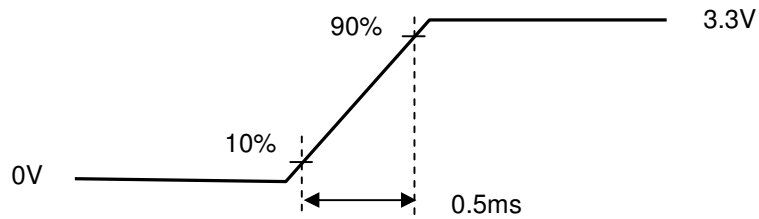
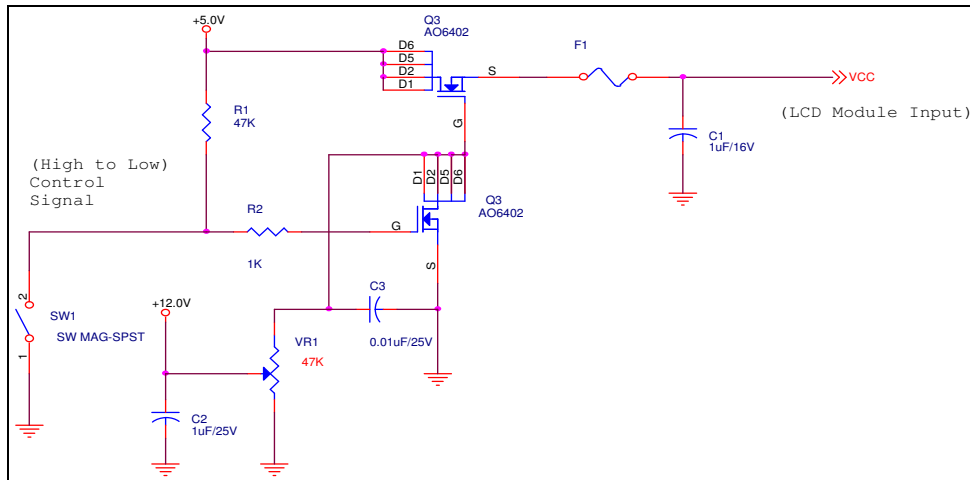

Vin rising time

5.1.2 Signal Electrical Characteristics

Input signals shall be low or High-impedance state when VDD is off.

It is recommended to refer the specifications of THC63LVDF84A (Thine Electronics Inc.) in detail.

Signal electrical characteristics are as follows;

Parameter	Condition	Min	Max	Unit
Vth	Differential Input High Threshold (Vcm=+1.2V)	-	100	[mV]
Vtl	Differential Input Low Threshold (Vcm=+1.2V)	-100	-	[mV]
Vcm	Differential Input Common Mode Voltage	1.125	1.375	[V]

Note: LVDS Signal Waveform

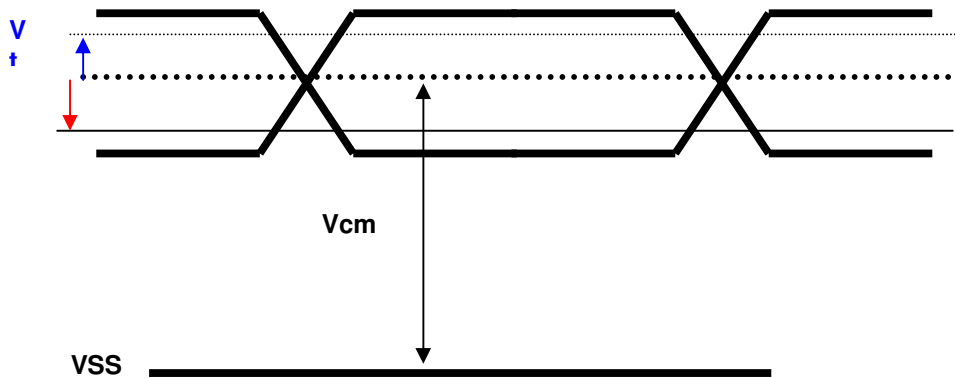



Product Specification

AU OPTRONICS CORPORATION

5.2 Backlight Unit

LED Parameter guideline for LED driving selection (Ref. Remark 1)

Parameter	Symbol	Min	Typ	Max	Units	Condition
LED Forward Voltage	V_F	2.95	3.15	3.4	[Volt]	($T_a=25^{\circ}\text{C}$)
LED Forward Current	I_F			20	[mA]	($T_a=25^{\circ}\text{C}$)
LED Power consumption	P_{LED}			3.4	[Watt]	($T_a=25^{\circ}\text{C}$) Note 1
LED Life-Time	N/A	12,000	-	-	Hour	($T_a=25^{\circ}\text{C}$) $I_F=20\text{ mA}$ Note 2
Output PWM frequency	FPWM	-	200	20K	Hz	
Duty ratio	--	10	--	100	%	

Note 1: Calculator value for reference $I_F \times V_F \times 42 / \text{efficiency}(85\%) = P(\text{typ.})$

Note 2: The LED life-time define as the estimated time to 50% degradation of initial luminous.

6. Signal Characteristic

6.1 Pixel Format Image

Following figure shows the relationship of the input signals and LCD pixel format.

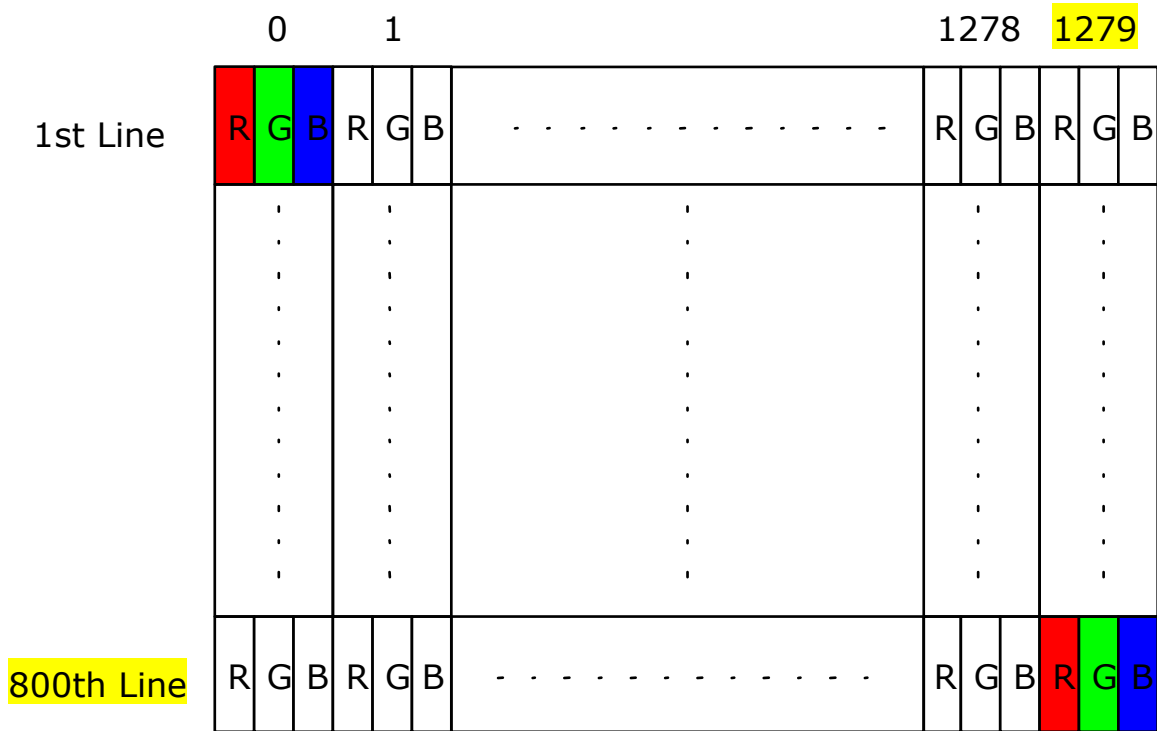

6.2 The input data format

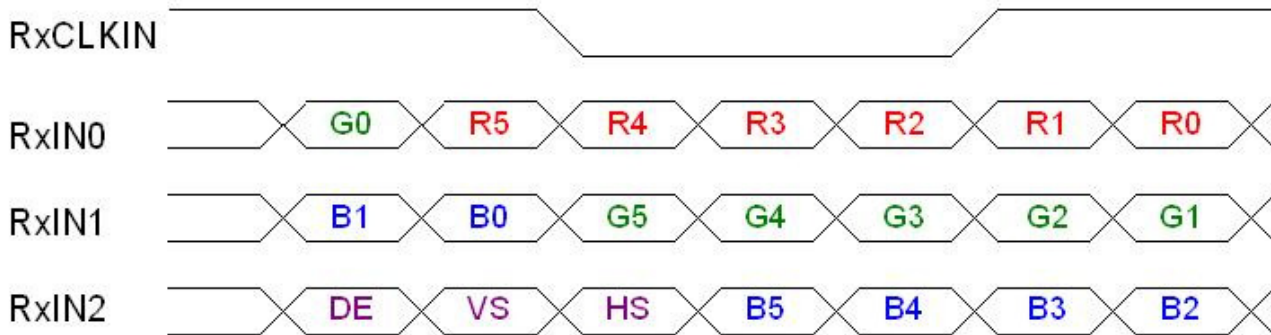

Signal Name	Description	
R5 R4 R3 R2 R1 R0	Red Data 5 (MSB) Red Data 4 Red Data 3 Red Data 2 Red Data 1 Red Data 0 (LSB)	Red-pixel Data Each red pixel's brightness data consists of these 6 bits pixel data.
G5 G4 G3 G2 G1 G0	Green Data 5 (MSB) Green Data 4 Green Data 3 Green Data 2 Green Data 1 Green Data 0 (LSB)	Green-pixel Data Each green pixel's brightness data consists of these 6 bits pixel data.
B5 B4 B3 B2 B1 B0	Blue Data 5 (MSB) Blue Data 4 Blue Data 3 Blue Data 2 Blue Data 1 Blue Data 0 (LSB)	Blue-pixel Data Each blue pixel's brightness data consists of these 6 bits pixel data.
RxCLKIN	Data Clock	The typical frequency is 69.3 MHz. The signal is used to strobe the pixel data and DE signals. All pixel data shall be valid at the falling edge when the DE signal is high.
DE	Display Timing	This signal is strobed at the falling edge of RxCLKIN. When the signal is high, the pixel data shall be valid to be displayed.
VS	Vertical Sync	The signal is synchronized to RxCLKIN .
HS	Horizontal Sync	The signal is synchronized to RxCLKIN .

Note: Output signals from any system shall be low or High-impedance state when VDD is off.

6.3 Signal Description/Pin Assignment

LVDS is a differential signal technology for LCD interface and high speed data transfer device.

Pin	Signal	Description
1	NC	No Connection (Reserved for supplier)
2	AVDD	Power Supply, 3.3V (typical)
3	AVDD	Power Supply, 3.3V (typical)
4	DVDD	DDC 3.3V power
5	NC	No Connection(reserve for AUO Test)
6	SCL	DDC Clock
7	SDA	DDC Data
8	Rin0-	- LVDS differential data input (R0-R5, G0)
9	Rn0+	+ LVDS differential data input (R0-R5, G0)
10	GND	Ground
11	Rin1-	- LVDS differential data input (G1-G5, B0-B1)
12	Rn1+	+ LVDS differential data input (G1-G5, B0-B1)
13	GND	Ground
14	Rin2-	- LVDS differential data input (B2-B5,HS,VS, DE)
15	Rn2+	+ LVDS differential data input (B2-B5,HS,VS, DE)
16	GND	Ground
17	Clkin-	- LVDS differential clock input
18	Clkin+	+ LVDS differential clock input
19	GND	Ground
20	NC	No Connection
21	NC	No Connection
22	GND	Ground
23	NC	No Connection
24	NC	No Connection
25	GND	Ground
26	NC	No Connection
27	NC	No Connection
28	GND	Ground
29	NC	No Connection
30	NC	No Connection
31	VBL-	LED Ground
32	VBL-	LED Ground
33	VBL-	LED Ground
34	NC	No Connection (Reserved for supplier)
35	VBL+	LED Power Supply 7V-20V
36	VBL+	LED Power Supply 7V-20V
37	VBL+	LED Power Supply 7V-20V
38	BLIM	PWM for luminance control (200~1KHz, 3.3V, 10~100%)
39	BL_Enable	BL On/Off (On: 2.0~3.3V, Off: 0~0.5V)
40	NC	No Connection (Reserved for supplier)

Note1: Start from right side

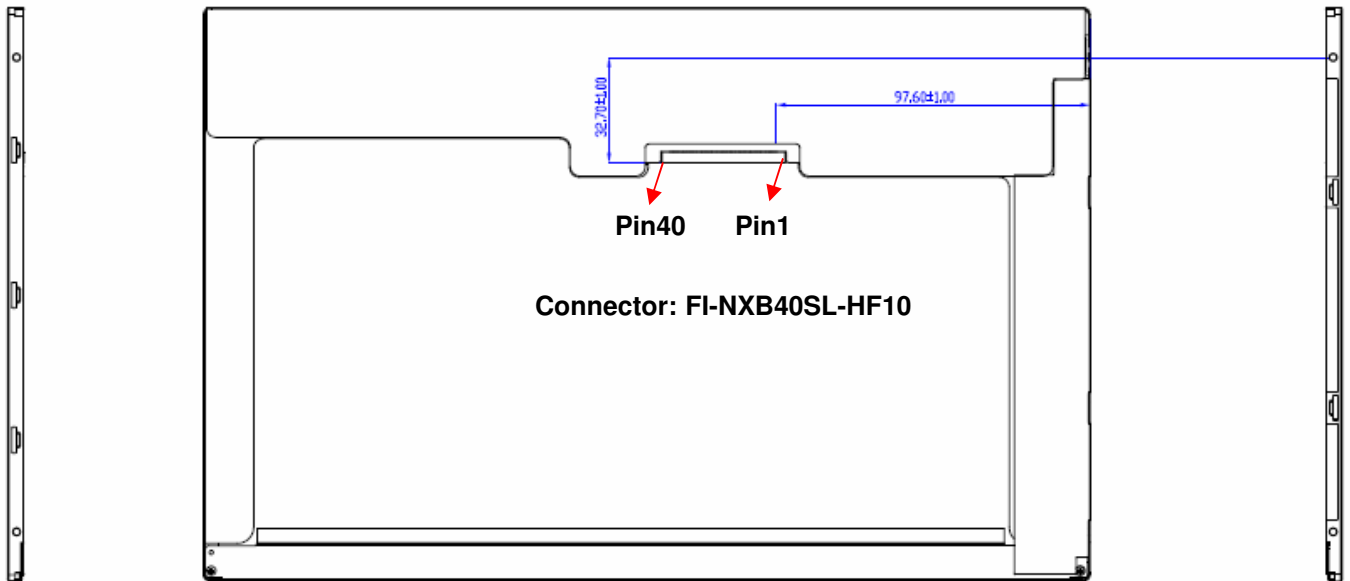

Note2: Input signals shall be low or High-impedance state when VDD is off.

internal circuit of LVDS inputs are as following.

The module uses a 100ohm resistor between positive and negative data lines of each receiver input

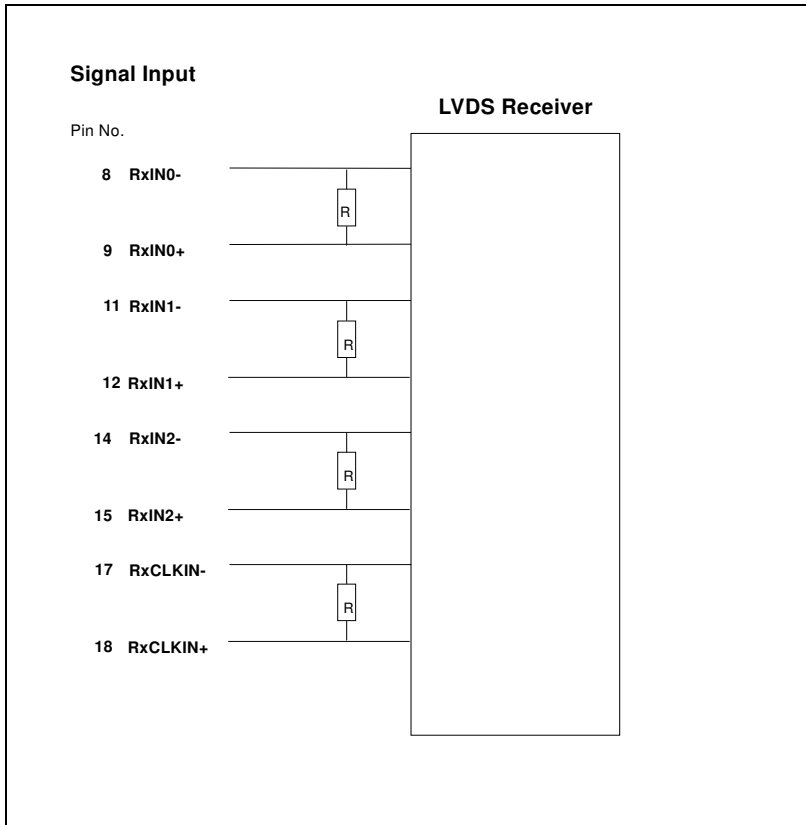

6.4 Interface Timing

6.4.1 Timing Characteristics

Basically, interface timings should match the 1280x800 /60Hz manufacturing guide line timing.

Parameter	Symbol	Min.	Typ.	Max.	Unit	
Frame Rate	-	-	60	-	Hz	
Clock frequency	$1/ T_{\text{Clock}}$	50-	69.3	80-	MHz	
Vertical Section	Period	T_V	803	816	1023	T_{Line}
	Active	T_{VD}	800	800	800	
	Blanking	T_{VB}	3	16	223	
Horizontal Section	Period	T_H	1303	1416	2047	T_{Clock}
	Active	T_{HD}	1280	1280	1280	
	Blanking	T_{HB}	23	136	767	

Note : DE mode only

6.4.2 Timing diagram

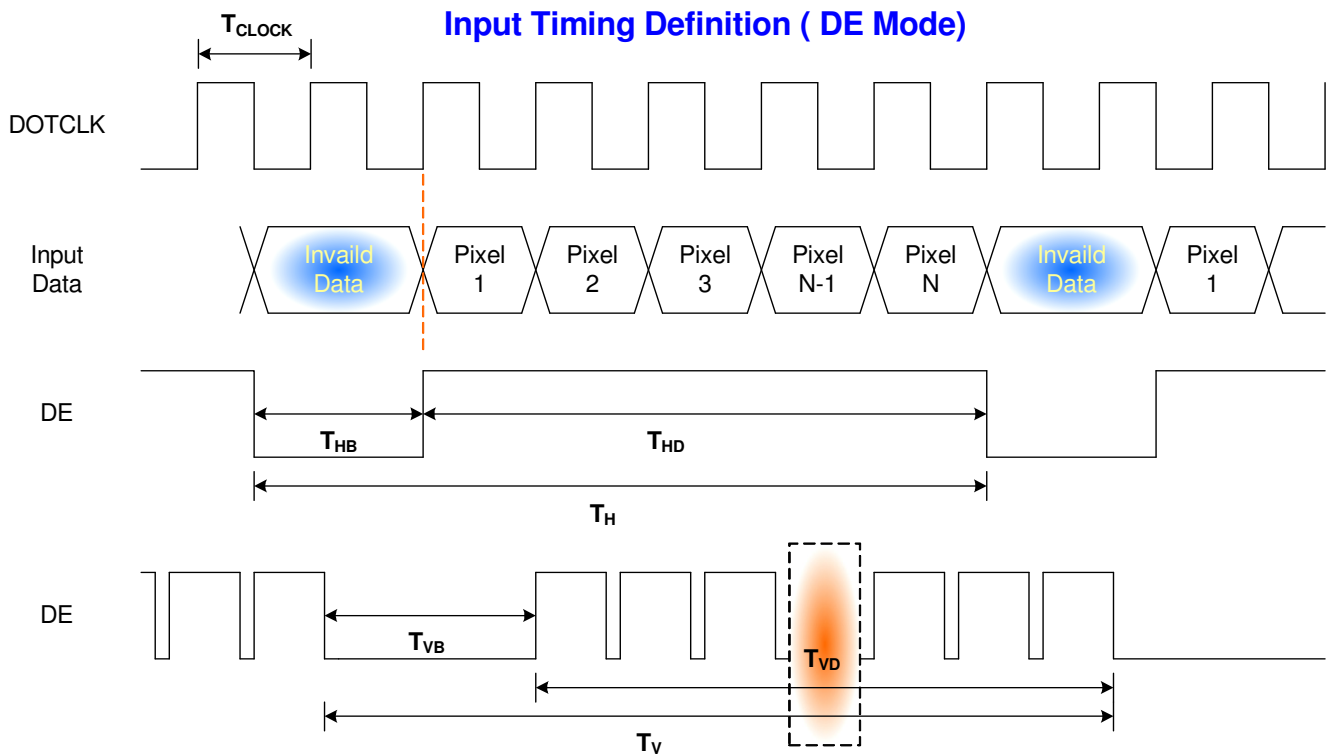

6.5 Power ON /OFF Sequence

VDD power on/off sequence is as follows. Interface signals are also shown in the chart. Signals from any system shall be Hi-Z state or low level when VDD is off

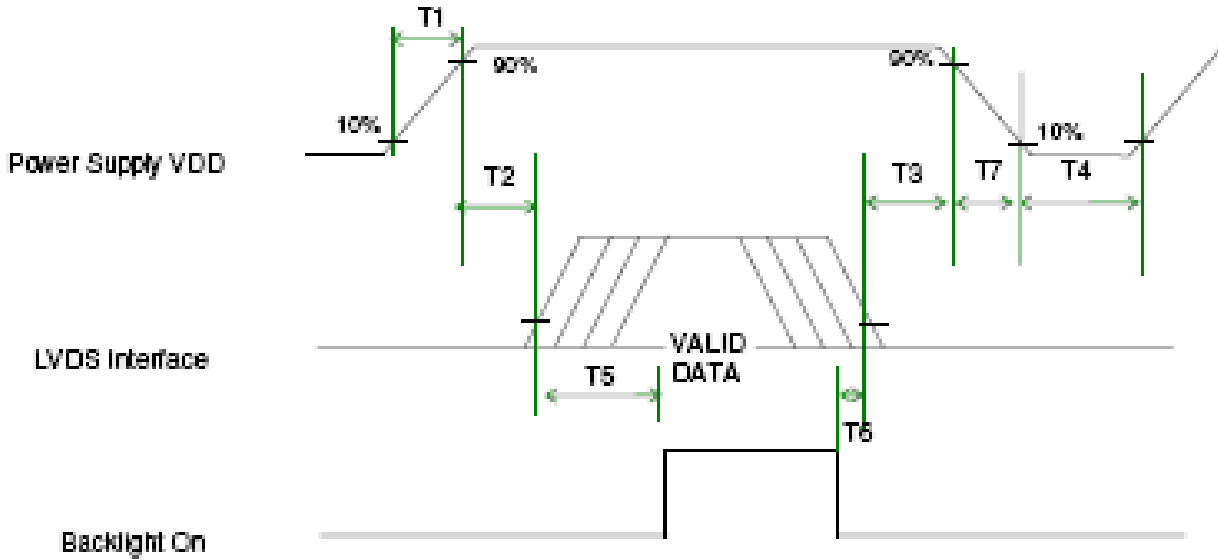

Power Sequence Timing

Parameter	Value			Units
	Min.	Typ.	Max.	
T1	0.5	-	10	ms
T2	0	-	50	
T3	0	-	50	
T4	400	-	-	
T5	200	-	-	
T6	200	-	-	
T7	0	-	10	

LED on/off sequence is as follows. Interface signals are also shown in the chart.

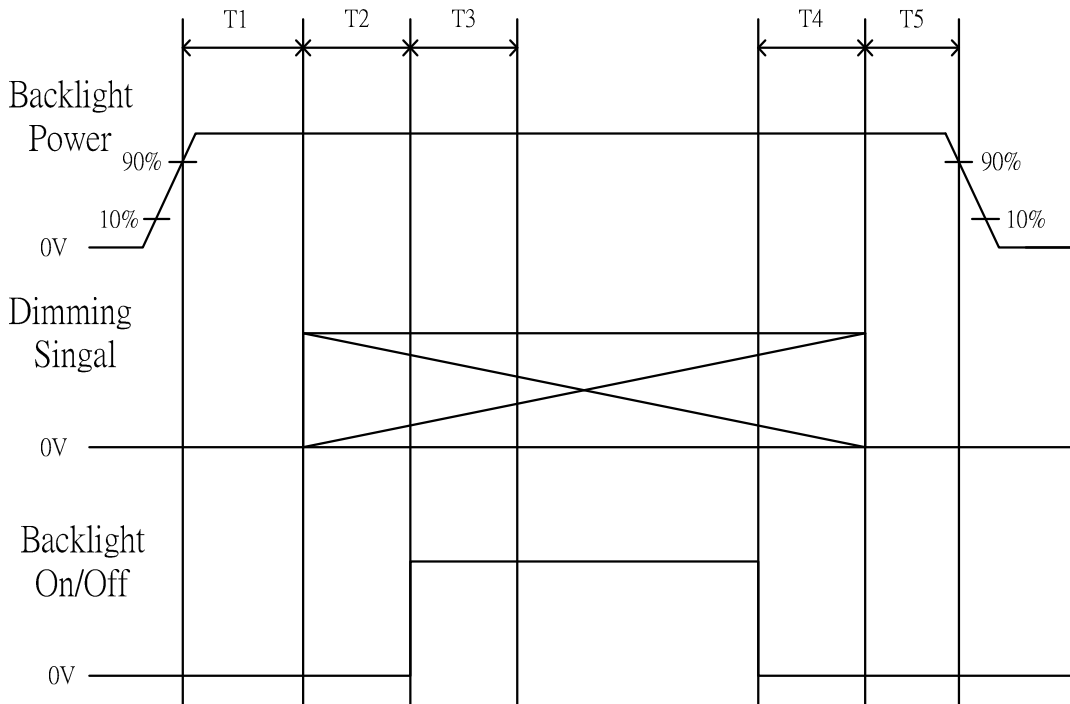

Symbol	Values			Unit
	Min	Typ	Max	
T1	10	---	---	ms
T2	10	---	---	ms
T3	50	---	---	ms
T4	0	---	---	ms
T5	10	---	---	ms

Note: The duty of LED dimming signal should be more than 20% in T2 and T3.

7. Connector Description

Physical interface is described as for the connector on module.

These connectors are capable of accommodating the following signals and will be following components.

7.1 TFT LCD Module

Connector Name / Designation	For Signal Connector
Manufacturer	Japan Aviation Electronics Industry, LTD
Type / Part Number	FI-NXB40SL-HF10 or compatible
Mating Housing/Part Number	FI-NX40CL or compatible

8. 8. LED Driving Specification

8.1 Connector Description

It is a integrative interface and comibe into LVDS connector. The type and mating refer to section 7.

8.2 Pin Assignment

PIN#	Signal Name	Description
31	VLED_GND	LED Ground
32	VLED_GND	LED Ground
33	VLED_GND	LED Ground
34	NC	No Connection
35	VLED	LED Power Supply 7V-20V
36	VLED	LED Power Supply 7V-20V
37	VLED	LED Power Supply 7V-20V
38	S_PWMIN	System PWM signal Input
39	LED_EN	LED enable pin (+3V input)
40	NC	No Connect (Reserve for AUO)



9. Vibration and Shock Test

9.1 Vibration Test

Test Spec:

- Test method: Non-Operation
- Acceleration: 1.5 G
- Frequency: 10 - 500Hz Random
- Sweep: 30 Minutes each Axis (X, Y, Z)

9.2 Shock Test Spec:

Test Spec:

- Test method: Non-Operation
- Acceleration: 220 G , Half sine wave
- Active time: 2 ms
- Pulse: X,Y,Z .one time for each side

10. Reliability

Items	Required Condition	Note
Temperature Humidity Bias	Ta= 40°C, 90%RH, 300h	
High Temperature Operation	Ta= 50°C, Dry, 300h	
Low Temperature Operation	Ta= 0°C, 300h	
High Temperature Storage	Ta= 60°C, 300h	
Low Temperature Storage	Ta= -20°C, 300h	
Thermal Shock Test	Ta=-20°C to 60°C, Duration at 30 min, 100 cycles	
ESD	Contact : ±8 KV Air : ±15 KV	Note 1

Note1: According to EN 61000-4-2 , ESD class B: Some performance degradation allowed. No data lost
 . Self-recoverable. No hardware failures.

Remark: MTBF (Excluding the LED): 30,000 hours with a confidence level 90%

11. Mechanical Characteristics

11.1 LCM Outline Dimension

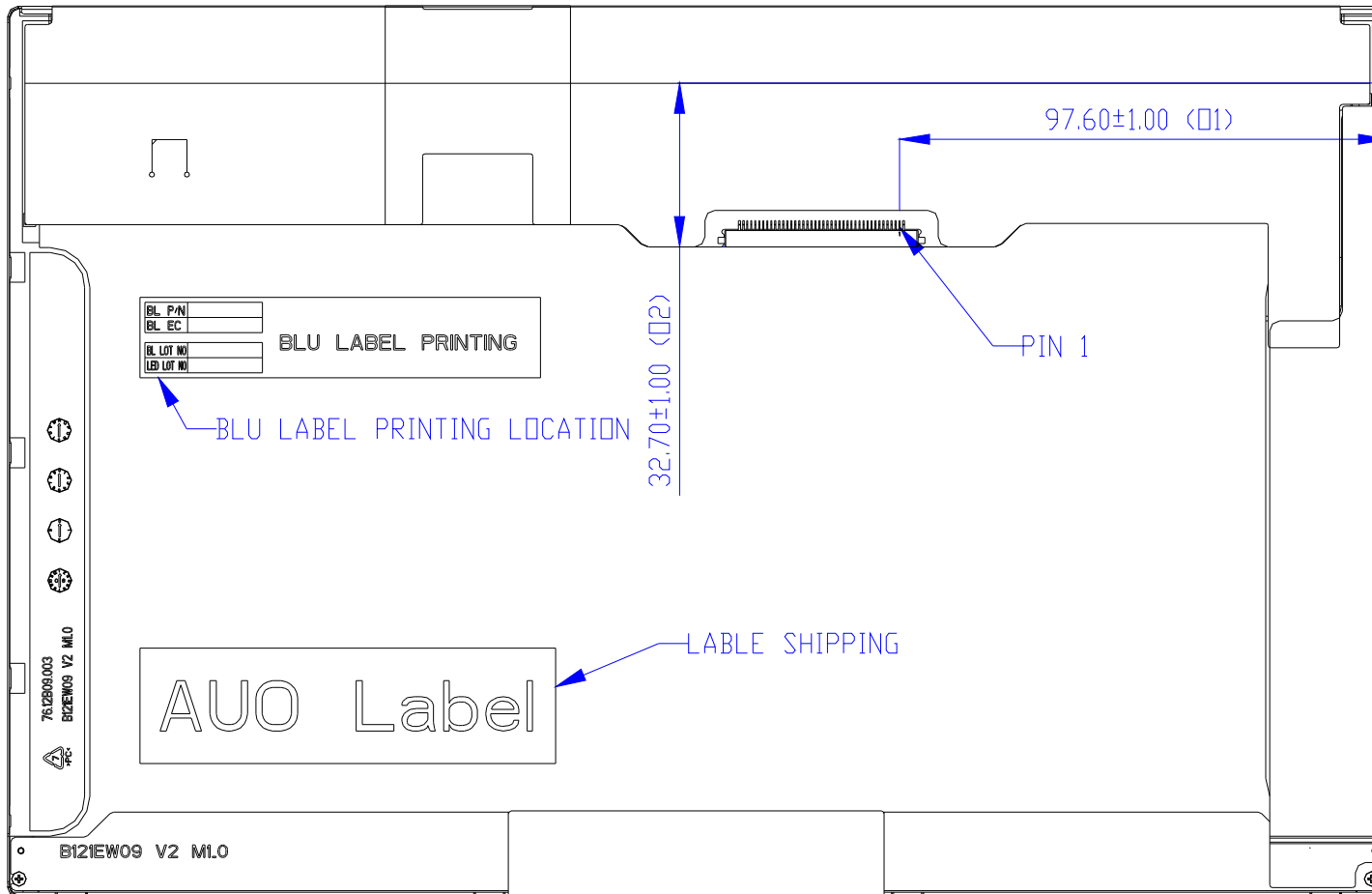

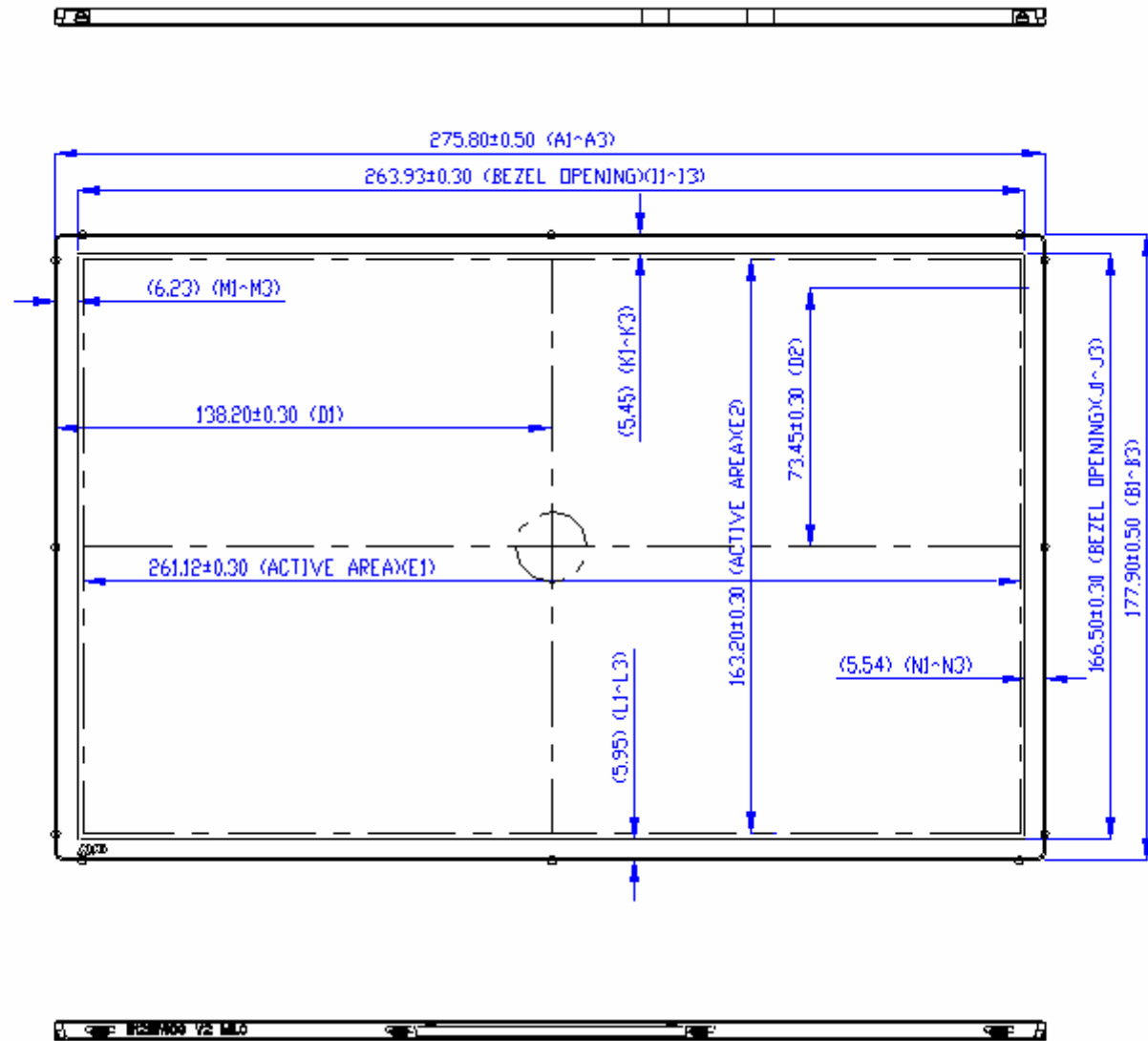
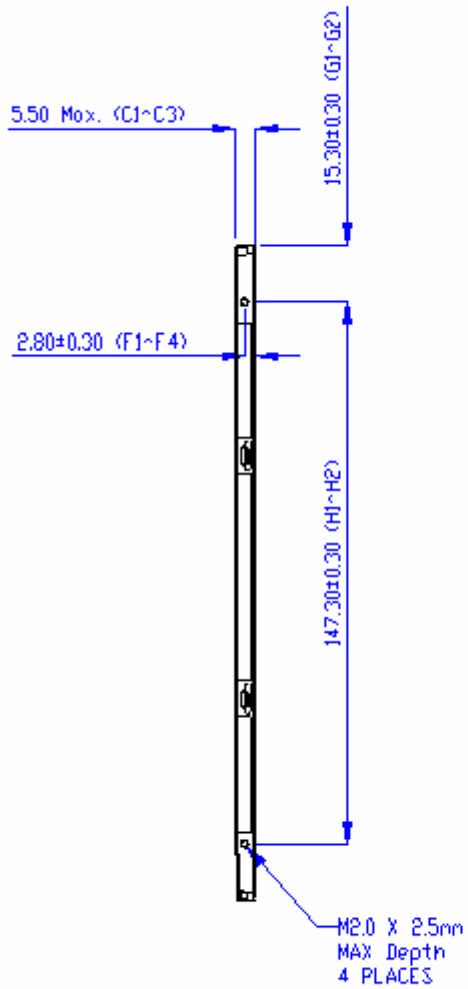

11.2 Screw Hole Depth and Center Position

Screw hole minimum depth, from side surface = 2.1 mm (See drawing)

Screw hole center location, from front surface = 2.8 ± 0.2 mm (See drawing)

Screw Torque: Maximum 2.5 kgf-cm

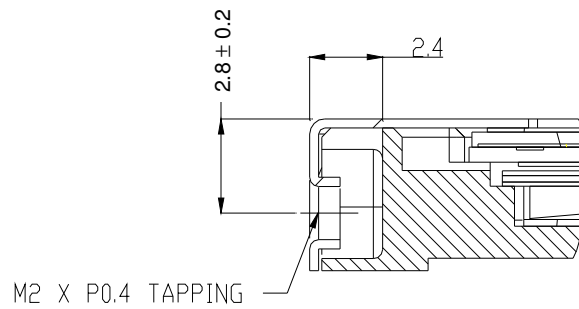

12. Shipping and Package

12.1 Shipping Label Format

 *XXXXXXXXXXXXXXXX-XXXXX*	Manufactured MMVVV Model No: B121EW09 AU Optronics	V.2 0AXXG	 xxxxxxx	
 CT: C XXXX XX XX XX XXX	HW: 0A FW:1			

12.2 Carton package

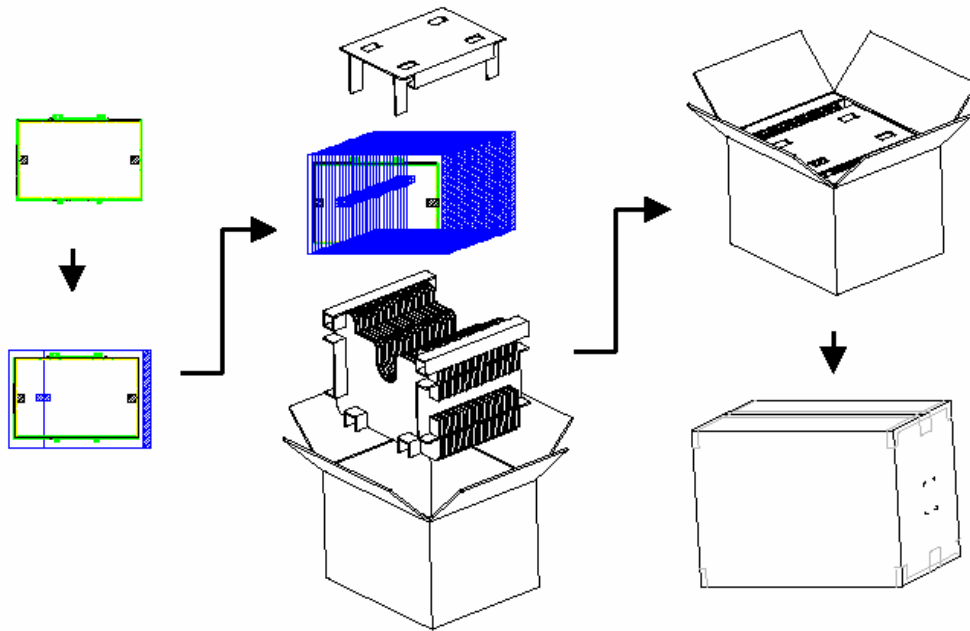

12.3 Shipping package of palletizing sequence

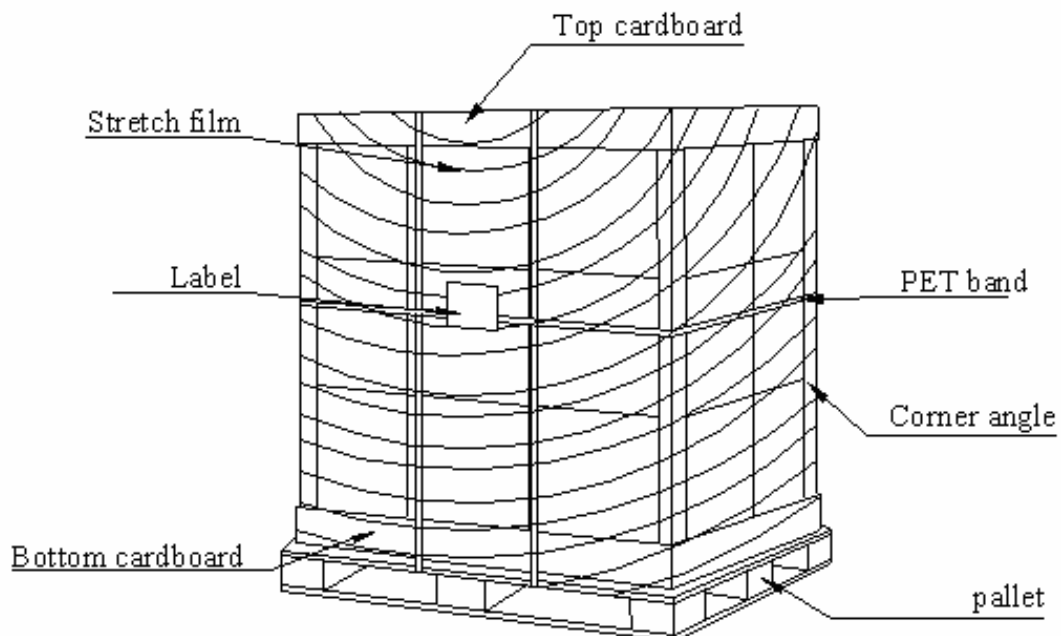

13. Appendix: EDID description

Address	FUNCTION	Value	Value	Value
HEX		HEX	BIN	DEC
00	Header	00	00000000	0
01		FF	11111111	255
02		FF	11111111	255
03		FF	11111111	255
04		FF	11111111	255
05		FF	11111111	255
06		FF	11111111	255
07		00	00000000	0
08	EISA Manuf. Code LSB	06	00000110	6
09	Compressed ASCII	AF	10101111	175
0A	Product Code=44	14	00010100	20
0B	hex, LSB first=44	92	10010010	146
0C	32-bit ser #	00	00000000	0
0D		00	00000000	0
0E		00	00000000	0
0F		00	00000000	0
10	Week of manufacture	01	00000001	1
11	Year of manufacture	12	00010010	18
12	EDID Structure Ver#=1	01	00000001	1
13	EDID revision #=3	03	00000011	3
14	Video input def. (digital I/P, non-TMDS, CRGB)	80	10000000	128
15	Max H image size (rounded to cm)	1A	00011010	26
16	Max V image size (rounded to cm)	10	00010000	16
17	Display Gamma=2.2	78	01111000	120
18	Feature support (no DPMS, Active OFF, RGB, trng Blk#1)	0A	00001010	10
19	Red/green low bits (Lower 2:2:2:2 bits)	08	00001000	8
1A	Blue/white low bits (Lower 2:2:2:2 bits)	B5	10110101	181
1B	Red x=0.575	8F	10001111	143
1C	Red y=0.335	59	01011001	89
1D	Green x=0.315	57	01010111	87
1E	Green y=0.55	8F	10001111	143
1F	Blue x=0.155	26	00100110	38
20	Blue y=0.135	1B	00011011	27
21	White x=0.313	50	01010000	80
22	White y=0.329	54	01010100	84
23		00	00000000	0
24		00	00000000	0
25		00	00000000	0
26		01	00000001	1
27		01	00000001	1
28		01	00000001	1
29		01	00000001	1
2A		01	00000001	1
2B		01	00000001	1
2C		01	00000001	1
2D		01	00000001	1
2E		01	00000001	1



Product Specification

AU OPTRONICS CORPORATION

2F		01	00000001	1
30		01	00000001	1
31		01	00000001	1
32		01	00000001	1
33		01	00000001	1
34		01	00000001	1
35		01	00000001	1
36	Pixel Clock/10000 LSB	12	00010010	18
37	Pixel Clock/10000 USB	1B	00011011	27
38	Horz active Lower 8bits	00	00000000	0
39	Horz blanking Lower 8bits	7B	01111011	123
3A	HorzAct:HorzBlnk Upper 4:4 bits	50	01010000	80
3B	Vertical Active Lower 8bits	20	00100000	32
3C	Vertical Blanking Lower 8bits	15	00010101	21
3D	Vert Act : Vertical Blanking (upper 4:4 bit)	30	00110000	48
3E	HorzSync. Offset	30	00110000	48
3F	HorzSync.Width	20	00100000	32
40	VertSync.Offset =3 line	36	00110110	54
41	VertSync.Offset =6 line	00	00000000	0
42	Horizontal Image Size=261.12 mm	05	00000101	5
43	Vertical Image Size=163.2 mm	A3	10100011	163
44		10	00010000	16
45		00	00000000	0
46		00	00000000	0
47		18	00011000	24
48		00	00000000	0
49		00	00000000	0
4A		00	00000000	0
4B		0F	00001111	15
4C	Version	00	00000000	0
4D		00	00000000	0
4E		00	00000000	0
4F	Link Type(LVDS Link, MSB justified)	00	00000000	0
50	Pixel and link component format(6-bit panel interface)	00	00000000	0
51	Panel features (No inverter)	00	00000000	0
52		00	00000000	0
53		00	00000000	0
54		00	00000000	0
55		00	00000000	0
56		00	00000000	0
57		00	00000000	0
58		00	00000000	0
59		20	00100000	32
5A		00	00000000	0
5B		00	00000000	0
5C		00	00000000	0
5D		FE	11111110	254
5E		00	00000000	0
5F	A	41	01000001	65
60	U	55	01010101	85
61	O	4F	01001111	79
62		0A	00001010	10



Product Specification

AU OPTRONICS CORPORATION

63		20	00100000	32
64		20	00100000	32
65		20	00100000	32
66		20	00100000	32
67		20	00100000	32
68		20	00100000	32
69		20	00100000	32
6A		20	00100000	32
6B		20	00100000	32
6C	Detailed timing/monitor	00	00000000	0
6D	descriptor #4	00	00000000	0
6E		00	00000000	0
6F		FE	11111110	254
70		00	00000000	0
71	B	42	01000010	66
72	1	31	00110001	49
73	2	32	00110010	50
74	1	31	00110001	49
75	E	45	01000101	69
76	W	57	01010111	87
77	0	30	00110000	48
78	9	39	00111001	57
79		20	00100000	32
7A	V	56	01010110	86
7B	2	32	00110010	50
7C		20	00100000	32
7D		0A	00001010	10
7E	Extension Flag	00	00000000	0
7F	Checksum	4E	01001110	78