

mass integrated

global part distribution • product lifecycle partner
excess inventory management • value-ad service provider



Data sheet provided by Mass Integrated

massintegrated.com • displayalliance.com

Please call +1.978.465.6190
Email: sales@massintegrated.com



ISO 9001: 2008

Mass Integrated complies with all DMCA takedown notices. Please send a formal DMCA Takedown Notice to Mass Integrated Systems, Inc. • 18 Henry Graf Jr. Road, Unit 1 • Newburyport, MA 01950.



This Datasheet has been downloaded from:

DisplayAlliance.com

Please call +1 (978) 465-6190 or email sales@massintegrated.com for a quote.



[ISO 9001 : 2008](#)



Product Specification

AU OPTRONICS CORPORATION

(V) Preliminary Specifications

() Final Specifications

Module	14.0" HD Color TFT-LCD with LED Backlight design
Model Name	B140XW02 V0 (0A)
Note ()	<i>LED Backlight with driving circuit design</i>

Customer	Date
<u>ASUS</u>	
Checked & Approved by	Date
_____	_____
Note: This Specification is subject to change without notice.	

Approved by	Date
<u>Ivy Lee</u>	<u>11/13/2008</u>
Prepared by	
<u>Jonken Fan</u>	<u>11/13/2008</u>
NBBU Marketing Division / AU Optronics corporation	



Contents

1. Handling Precautions	4
2. General Description.....	5
2.1 General Specification	5
2.2 Optical Characteristics.....	6
3. Functional Block Diagram.....	11
4. Absolute Maximum Ratings	12
4.1 Absolute Ratings of TFT LCD Module.....	12
4.2 Absolute Ratings of Backlight Unit.....	12
4.3 Absolute Ratings of Environment	12
5. Electrical characteristics	13
5.1 TFT LCD Module.....	13
5.2 Backlight Unit.....	15
6. Signal Characteristic	16
6.1 Pixel Format Image	16
6.2 The input data format.....	17
6.3 Signal Description/Pin Assignment	18
6.4 Interface Timing	22
7. Connector Description	25
7.1 TFT LCD Module.....	25
8. LED Driving Specification	26
8.1 Connector Description	26
8.2 Pin Assignment.....	26
9. Vibration and Shock Test.....	27
9.1 Vibration Test.....	27
9.2 Shock Test Spec:.....	27
10. Reliability	28
11. Mechanical Characteristics	29
11.1 LCM Outline Dimension.....	29
12. Shipping and Package	32
12.1 Shipping Label Format	32
12.2 Carton package	33
12.3 Shipping package of palletizing sequence.....	34
13. Appendix: EDID description	34



Product Specification

AU OPTRONICS CORPORATION

Record of Revision

Version and Date	Page	Old description	New Description	Remark
0.1 2008/10/13	All	First Edition for Customer		
0.2 2008/10/27	29	Old drawing	New drawing	
0.3 2008/11/04	29	Old drawing	New drawing (with bracket zoom-in)	
0.4 2008/11/13	20	Old drawing	New drawing (with new layout)	
	29	Old drawing	New drawing (with new layout)	



1. Handling Precautions

- 1) Since front polarizer is easily damaged, pay attention not to scratch it.
- 2) Be sure to turn off power supply when inserting or disconnecting from input connector.
- 3) Wipe off water drop immediately. Long contact with water may cause discoloration or spots.
- 4) When the panel surface is soiled, wipe it with absorbent cotton or other soft cloth.
- 5) Since the panel is made of glass, it may break or crack if dropped or bumped on hard surface.
- 6) Since CMOS LSI is used in this module, take care of static electricity and insure human earth when handling.
- 7) Do not open nor modify the Module Assembly.
- 8) Do not press the reflector sheet at the back of the module to any directions.
- 9) At the insertion or removal of the Signal Interface Connector, be sure not to rotate nor tilt the Interface Connector of the TFT Module.
- 11) After installation of the TFT Module into an enclosure (Notebook PC Bezel, for example), do not twist nor bend the TFT Module even momentary. At designing the enclosure, it should be taken into consideration that no bending/twisting forces are applied to the TFT Module from outside. Otherwise the TFT Module may be damaged.
- 12) Small amount of materials having no flammability grade is used in the LCD module. The LCD module should be supplied by power complied with requirements of Limited Power Source (IEC60950 or UL1950), or be applied exemption.
- 13) Disconnecting power supply before handling LCD modules, it can prevent electric shock, DO NOT TOUCH the electrode parts, cables, connectors and LED circuit part of TFT module that a LED light bar build in as a light source of back light unit. High voltage is supplied to these parts when power turn on.



Product Specification

AU OPTRONICS CORPORATION

2. General Description

B140XW02 V0 is a Color Active Matrix Liquid Crystal Display composed of a TFT LCD panel, a driver circuit, and LED backlight system. The screen format is intended to support the HD (1366(H) x 768(V)) screen and 262k colors (RGB 6-bits data driver) with LED backlight driving circuit. All input signals are LVDS interface compatible.

B140XW02 V0 is designed for a display unit of notebook style personal computer and industrial machine.

2.1 General Specification

The following items are characteristics summary on the table at 25 °C condition:

Items	Unit	Specifications			
Screen Diagonal	[mm]	14.0"			
Active Area	[mm]	309.399x173.952			
Pixels H x V		1366x3(RGB) x 768			
Pixel Pitch	[mm]	0.2265			
Pixel Format		B.G.R. Vertical Stripe			
Display Mode		Normally White			
White Luminance (I _{LED} =20mA) Note: I _{LED} is LED current	[cd/m ²]	220 typ. (5 points average) 187 min. (5 points average) (Note1)			
Luminance Uniformity		1.25 max. (5 points)			
Contrast Ratio		500 typ			
Response Time	[ms]	8 typ			
Nominal Input Voltage VDD	[Volt]	+3.3 typ.			
Power Consumption	[Watt]	4.5 max. (Include Logic and Blu power) (Note1)			
Weight	[Grams]	320 max.			
Physical Size with bracket & bottom PCBA.	[mm]		Min.	Typ.	Max.
		Length	329.9	330.4	330.9
		Width	198.1	198.6	199.1
		Thickness			3.6
Electrical Interface		1 channel LVDS			
Surface Treatment		Glare, Hardness 3H,			



Product Specification

AU OPTRONICS CORPORATION

Support Color		262K colors (RGB 6-bit)
Temperature Range Operating Storage (Non-Operating)	[°C] [°C]	0 to +50 -20 to +65
RoHS Compliance		RoHS Compliance

Note 1. Total power consumption including LED power efficiency under 4.5W max.

2.2 Optical Characteristics

The optical characteristics are measured under stable conditions at 25°C (Room Temperature) :

Item	Symbol	Conditions	Min.	Typ.	Max.	Unit	Note
White Luminance $I_{LED}=20mA$		5 points average	187	220	-	cd/m ²	1, 3, 4.
Viewing Angle	θ_R	Horizontal (Right)	40	45	-	degree	3, 8
	θ_L	CR = 10 (Left)	40	45	-		
	ϕ_H	Vertical (Upper)	10	15	-		
	ϕ_L	CR = 10 (Lower)	30	35	-		
Luminance Uniformity	δ_{5P}	5 Points	-	-	1.25		1, 2, 3
Contrast Ratio	CR		400	500	-		3, 5
Cross talk	%				4		3, 6
Response Time	T_r	Rising	-		-	msec	3, 7
	T_f	Falling	-		-		
	T_{RT}	Rising + Falling	-	8			
Color / Chromaticity Coordinates	Red x	CIE 1931		TBD			3
	Red y			TBD			
	Green x			TBD			
	Green y			TBD			
	Blue x			TBD			
	Blue y			TBD			
	White x		0.263	0.313	0.363		
	White y		0.279	0.329	0.379		
NTSC	%		-	45	-		

Note 1: 5 points position (Ref: Active area)

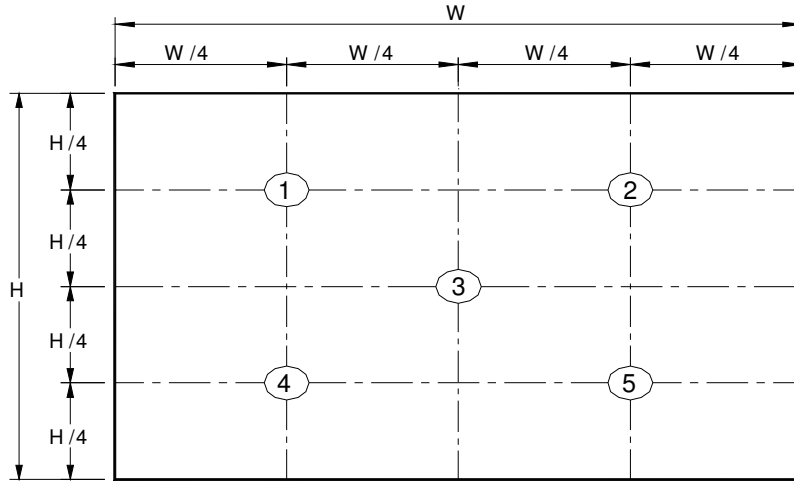

Note 2: The luminance uniformity of 5 or 13 points is defined by dividing the maximum luminance values by the minimum test point luminance

$$\delta_{W5} = \frac{\text{Maximum Brightness of five points}}{\text{Minimum Brightness of five points}}$$

$$\delta_{W13} = \frac{\text{Maximum Brightness of thirteen points}}{\text{Minimum Brightness of thirteen points}}$$

Note 3: Measurement method

The LCD module should be stabilized at given temperature for 30 minutes to avoid abrupt temperature change during measuring. In order to stabilize the luminance, the measurement should be executed after lighting Backlight for 30 minutes in a stable, windless and dark room, , and it should be measured in the center of screen.

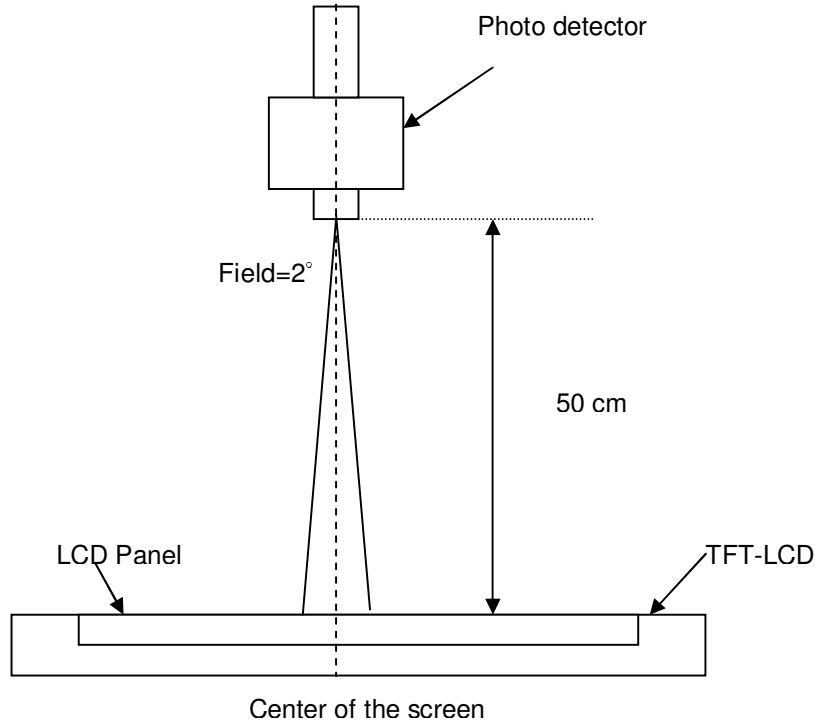

Note 4 : Definition of Average Luminance of White (Y_L):

Measure the luminance of gray level 63 at 5 points , $Y_L = [L (1)+ L (2)+ L (3)+ L (4)+ L (5)] / 5$

$L (x)$ is corresponding to the luminance of the point X at Figure in Note (1).

Note 5 : Definition of contrast ratio:

Contrast ratio is calculated with the following formula.

$$\text{Contrast ratio (CR)} = \frac{\text{Brightness on the "White" state}}{\text{Brightness on the "Black" state}}$$

Note 6 : Definition of Cross Talk (CT)

$$CT = | Y_B - Y_A | / Y_A \times 100 (\%)$$

Where

Y_A = Luminance of measured location without gray level 0 pattern (cd/m²)

Y_B = Luminance of measured location with gray level 0 pattern (cd/m²)

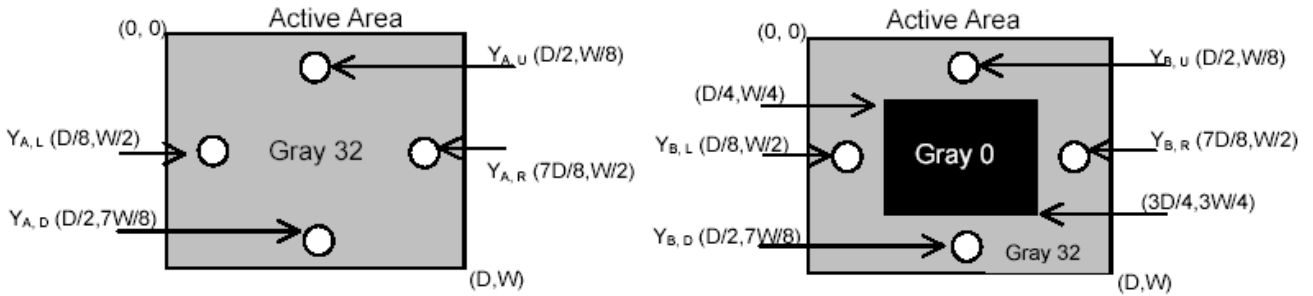

Note 7: Definition of response time:

The output signals of BM-7 or equivalent are measured when the input signals are changed from "Black" to "White" (falling time) and from "White" to "Black" (rising time), respectively. The response time interval between the 10% and 90% of amplitudes. Refer to figure as below.

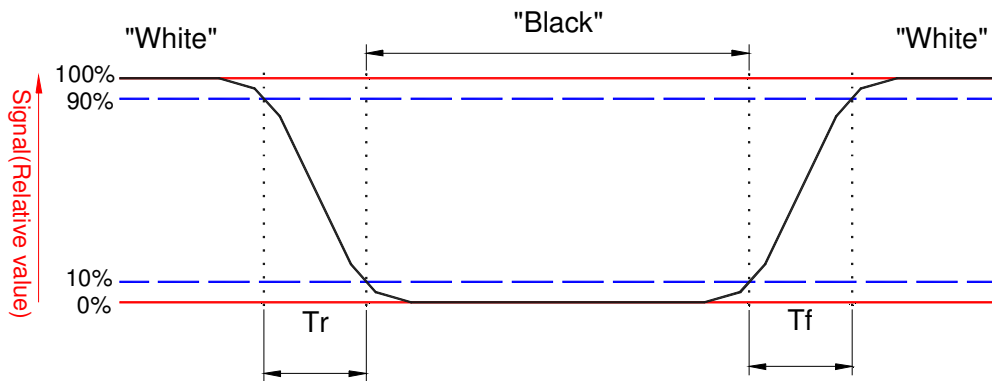

Note 8. Definition of viewing angle

Viewing angle is the measurement of contrast ratio ≥ 10 , at the screen center, over a 180° horizontal and 180° vertical range (off-normal viewing angles). The 180° viewing angle range is broken down as follows; 90° (θ) horizontal left and right and 90° (Φ) vertical, high (up) and low (down). The measurement direction is typically perpendicular to the display surface with the screen rotated about its center to develop the desired measurement viewing angle.

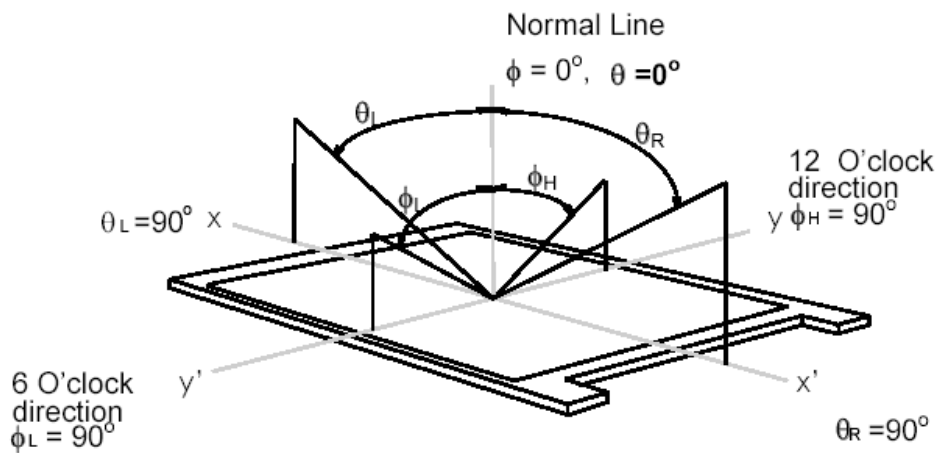

3. Functional Block Diagram

The following diagram shows the functional block of the 14.0 inches wide Color TFT/LCD 40 Pin (One ch/connector Module):

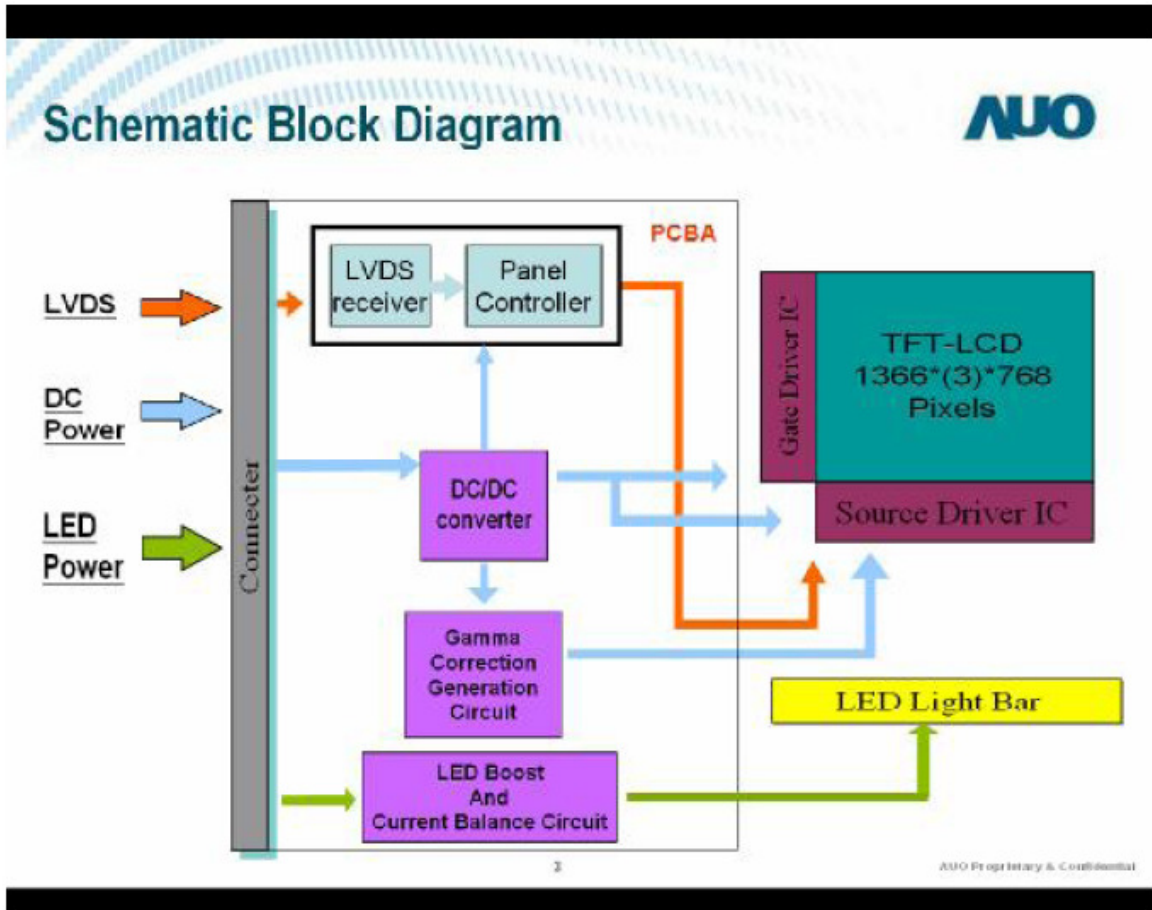

Figure 1 – General TFT LCD Block Diagram

4. Absolute Maximum Ratings

An absolute maximum rating of the module is as following:

4.1 Absolute Ratings of TFT LCD Module

Item	Symbol	Min	Max	Unit	Conditions
Logic/LCD Drive	V _{in}	-0.3	+4.0	[Volt]	Note 1,2

4.2 Absolute Ratings of Backlight Unit

Item	Symbol	Min	Max	Unit	Conditions
LED Driving Voltage	V _{LED}	-	36 (Row Output)	[Volt]	Note 1,2,3
LED Driving Current	I _{LED}	-	30 (Row Output)	[mA] rms	Note 1,2,3

4.3 Absolute Ratings of Environment

Item	Symbol	Min	Max	Unit	Conditions
Operating Temperature	TOP	0	+50	[°C]	Note 4
Operation Humidity	HOP	8	95	[%RH]	Note 4
Storage Temperature	TST	-20	+65	[°C]	Note 4
Storage Humidity	HST	5	95	[%RH]	Note 4

Note 1: At Ta (25°C)

Note 2: Permanent damage to the device may occur if exceed maximum values

Note 3: LED specification refer to section 5.2

Note 4: For quality performance, please refer to AUO IIS (Incoming Inspection Standard).

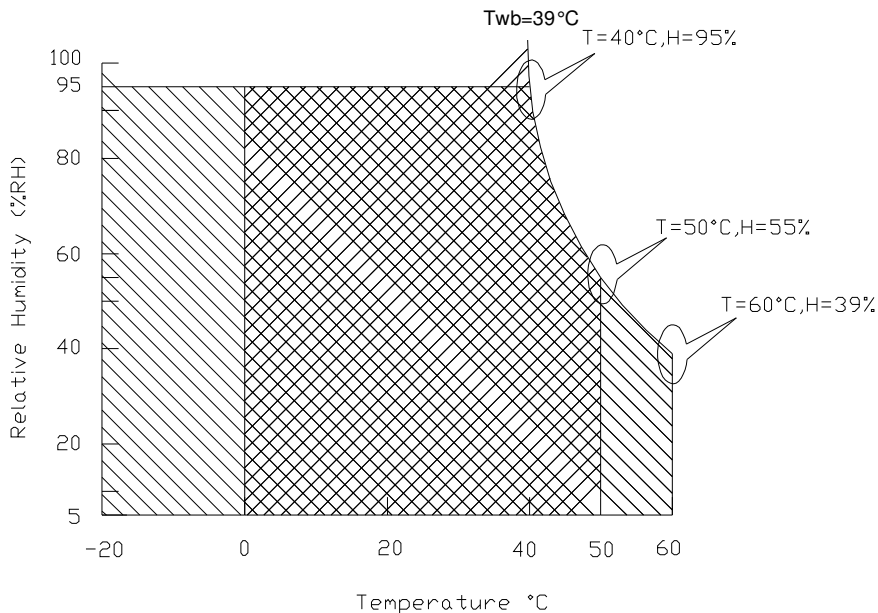

Operating Range 

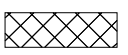
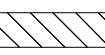
Storage Range  + 

5. Electrical characteristics

5.1 TFT LCD Module

5.1.1 Power Specification

Input power specifications are as follows;

The power specification are measured under 25°C and frame frequency under 60Hz

Symble	Parameter	Min	Typ	Max	Units	Note
VDD	Logic/LCD Drive Voltage	3.0	3.3	3.6	[Volt]	
PDD	VDD Power		0.9	1	[Watt]	Note 1/2
IDD	IDD Current		272	333	[mA]	Note 1/2
IRush	Inrush Current			2000	[mA]	Note 3
VDDrp	Allowable Logic/LCD Drive Ripple Voltage			100	[mV] p-p	

Note 1 : Maximum Measurement Condition : Black Pattern

Note 2 : Typical Measurement Condition: Black Pattern

Note 3 : Measure Condition

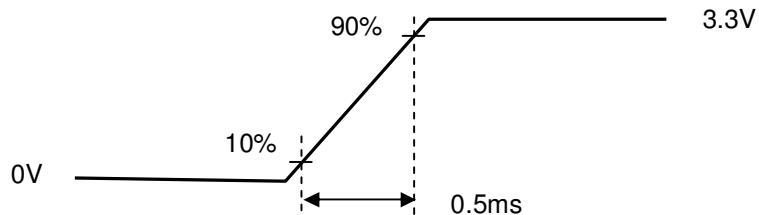
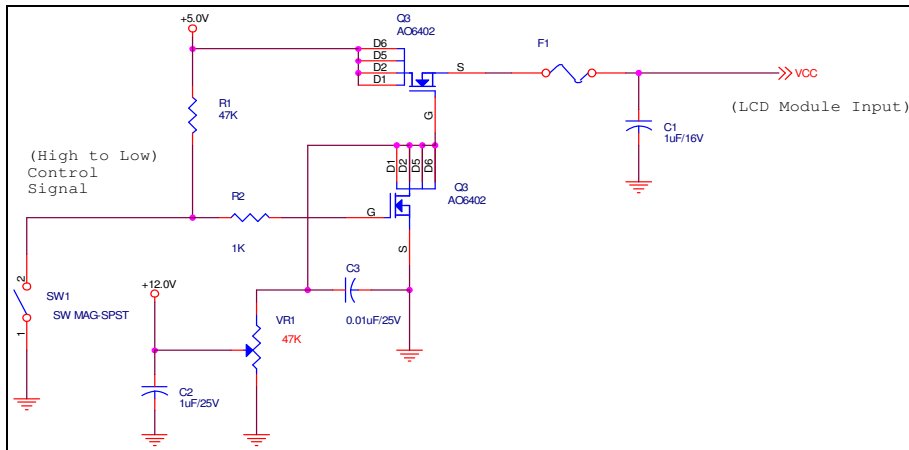

5.1.2 Signal Electrical Characteristics

Input signals shall be low or High-impedance state when VDD is off.

It is recommended to refer the specifications of THC63LVDF84A (Thine Electronics Inc.) in detail.

Signal electrical characteristics are as follows;

Parameter	Condition	Min	Max	Unit
Vth	Differential Input High Threshold (Vcm=+1.2V)	-	100	[mV]
Vtl	Differential Input Low Threshold (Vcm=+1.2V)	-100	-	[mV]
Vcm	Differential Input Common Mode Voltage	1.125	1.375	[V]

Note: LVDS Signal Waveform

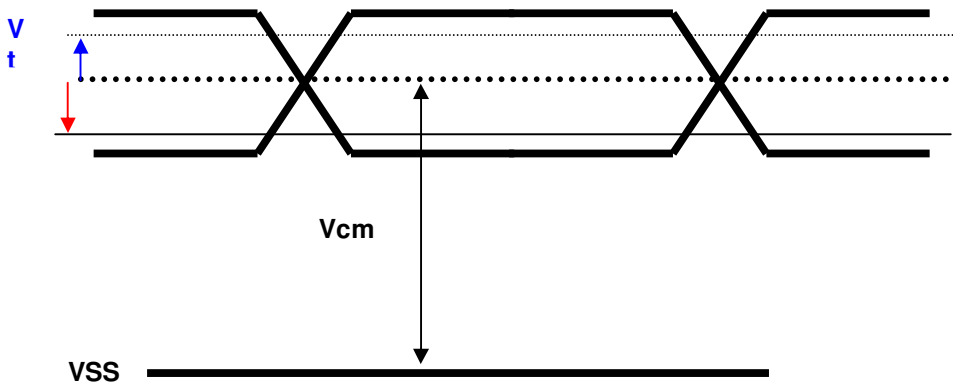



5.2 Backlight Unit

LED Parameter guideline for LED driving selection (Ref. Remark 1)

Parameter	Symbol	Min	Typ	Max	Units	Condition
LED Forward Voltage	V_F		3.2	3.4	[Volt]	(Ta=25°C)
LED Forward Current	I_F			20	[mA]	(Ta=25°C)
LED Power consumption	P_{LED}			3.5	[Watt]	(Ta=25°C) Note 1
LED Driving Input Voltage	V_{LED}	7	12	21	[Volt]	
LED Life-Time	N/A	12,000			Hour	(Ta=25°C) $I_F=20mA$ Note 2
Output PWM frequency	F_{PWM}	100	200	20K	Hz	
Duty ratio	--	5		100	%	

Note 1: Calculator value for reference $I_F \times V_F = P$

Note 2: The LED life-time define as the estimated time to 50% degradation of initial luminous.

6.2 The input data format

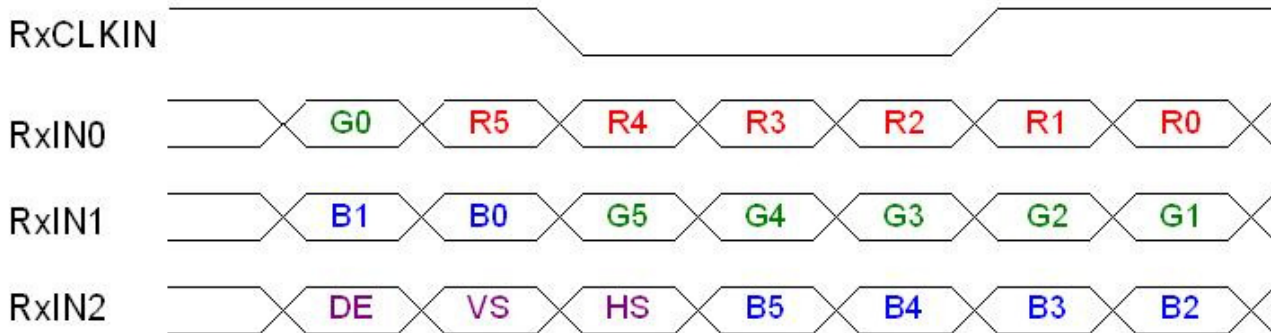

Signal Name	Description	
R5 R4 R3 R2 R1 R0	Red Data 5 (MSB) Red Data 4 Red Data 3 Red Data 2 Red Data 1 Red Data 0 (LSB)	Red-pixel Data Each red pixel's brightness data consists of these 6 bits pixel data.
G5 G4 G3 G2 G1 G0	Green Data 5 (MSB) Green Data 4 Green Data 3 Green Data 2 Green Data 1 Green Data 0 (LSB)	Green-pixel Data Each green pixel's brightness data consists of these 6 bits pixel data.
B5 B4 B3 B2 B1 B0	Blue Data 5 (MSB) Blue Data 4 Blue Data 3 Blue Data 2 Blue Data 1 Blue Data 0 (LSB)	Blue-pixel Data Each blue pixel's brightness data consists of these 6 bits pixel data.
RxCLKIN	Data Clock	The signal is used to strobe the pixel data and DE signals. All pixel data shall be valid at the falling edge when the DE signal is high.
DE	Display Timing	This signal is strobed at the falling edge of RxCLKIN. When the signal is high, the pixel data shall be valid to be displayed.
VS	Vertical Sync	The signal is synchronized to RxCLKIN .
HS	Horizontal Sync	The signal is synchronized to RxCLKIN .

Note: Output signals from any system shall be low or High-impedance state when VDD is off.

6.3 Signal Description/Pin Assignment

LVDS is a differential signal technology for LCD interface and high speed data transfer device.

B140XW02 V0		
Pin	Signal	Description
1	NC	No Connection (Reserve)
2	VDD	PowerSupply,3.3V(typical)
3	VDD	PowerSupply,3.3V(typical)
4	DVDD	DDC 3.3Vpower
5	NC	No Connection (Reserve)
6	SCL	DDCClock
7	SDA	DDCData
8	Rin0-	-LVDSdifferential data input(R0-R5,G0)
9	Rin0+	+LVDSdifferential data input(R0-R5,G0)
10	GND	Ground
11	Rin1-	-LVDSdifferential data input(G1-G5,B0-B1)
12	Rin1+	+LVDSdifferential data input(G1-G5,B0-B1)
13	GND	Ground
14	Rin2-	-LVDSdifferential data input(B2-B5,HS,VS,DE)
15	Rin2+	+LVDSdifferential data input(B2-B5,HS,VS,DE)
16	GND	Ground
17	ClkIN-	-LVDSdifferential clock input
18	ClkIN+	+LVDSdifferential clock input
19	GND	Ground
20	NC	No Connection (Reserve)
21	NC	No Connection (Reserve)
22	GND	Ground
23	NC	No Connection (Reserve)
24	NC	No Connection (Reserve)
25	GND	Ground–Shield
26	NC	No Connection (Reserve)
27	NC	No Connection (Reserve)
28	GND	Ground–Shield
29	NC	No Connection (Reserve)
30	NC	No Connection (Reserve)
31	VLED_GND	LED Ground
32	VLED_GND	LED Ground
33	VLED_GND	LED Ground
34	NC	No Connection (Reserve)
35	PWM	System PWM Signal Input
36	LED_EN	LED enable pin(+3V Input)



Product Specification

AU OPTRONICS CORPORATION

37	NC	No Connection (Reserve)
38	VLED	LED Power Supply 7V-21V
39	VLED	LED Power Supply 7V-21V
40	VLED	LED Power Supply 7V-21V

Note1:

Rear View

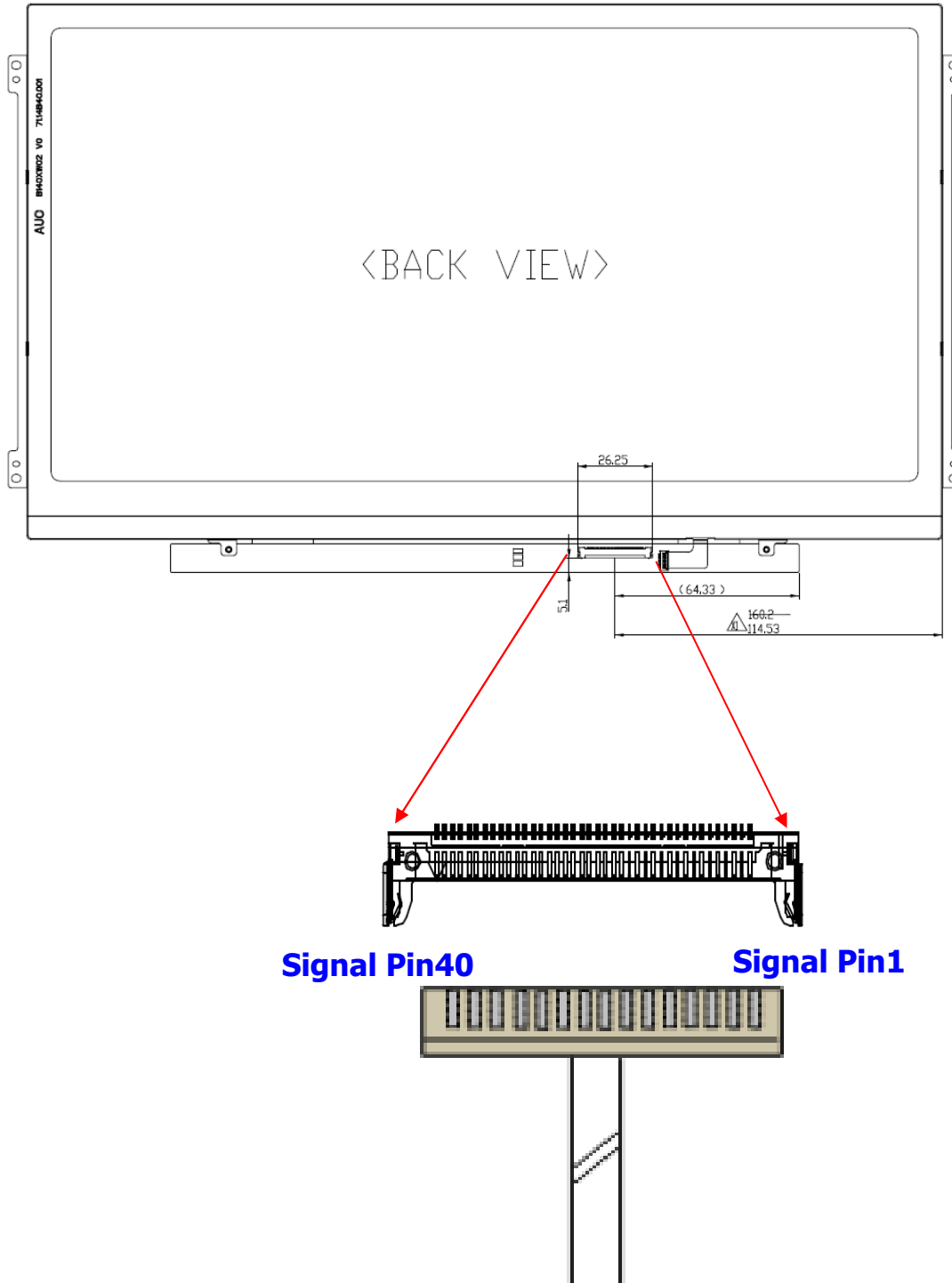

Note2: Input signals shall be low or High-impedance state when VDD is off.
 internal circuit of LVDS inputs are as following.

The module uses a 100ohm resistor between positive and negative data lines of each receiver input

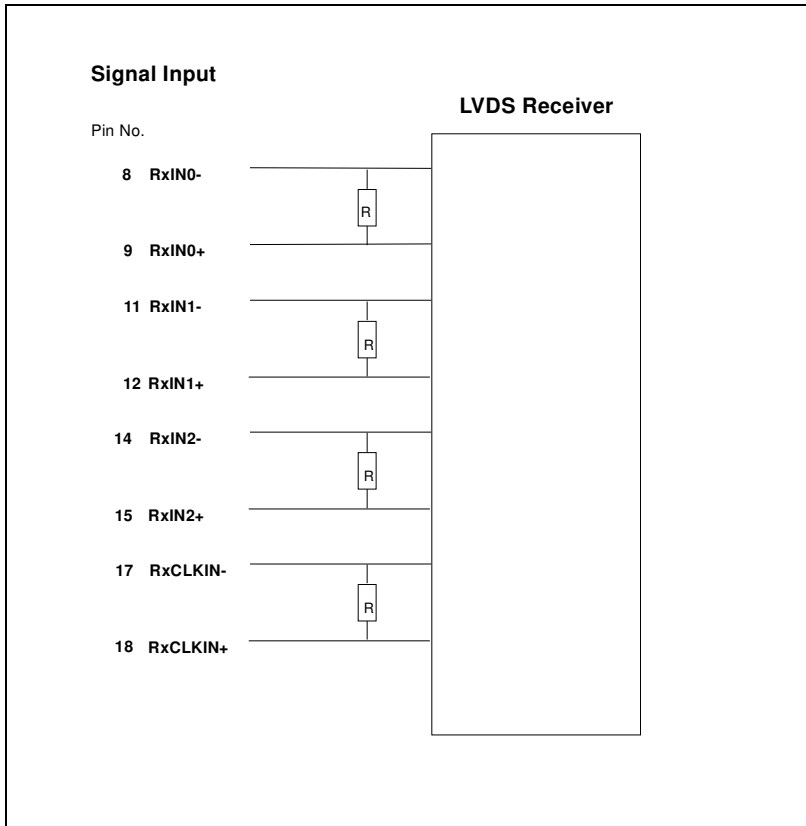

6.4 Interface Timing

6.4.1 Timing Characteristics

Basically, interface timings should match the 1366x768 /60Hz manufacturing guide line timing.

Parameter	Symbol	Min.	Typ.	Max.	Unit
Frame Rate	-		60		Hz
Clock frequency	$1/T_{\text{Clock}}$		72		MHz
Vertical Section	Period	T_V	803		T_{Line}
	Active	T_{VD}	768		
	Blanking	T_{VB}	35		
Horizontal Section	Period	T_H	1494		T_{Clock}
	Active	T_{HD}	1366		
	Blanking	T_{HB}	128		

Note : DE mode only

6.4.2 Timing diagram

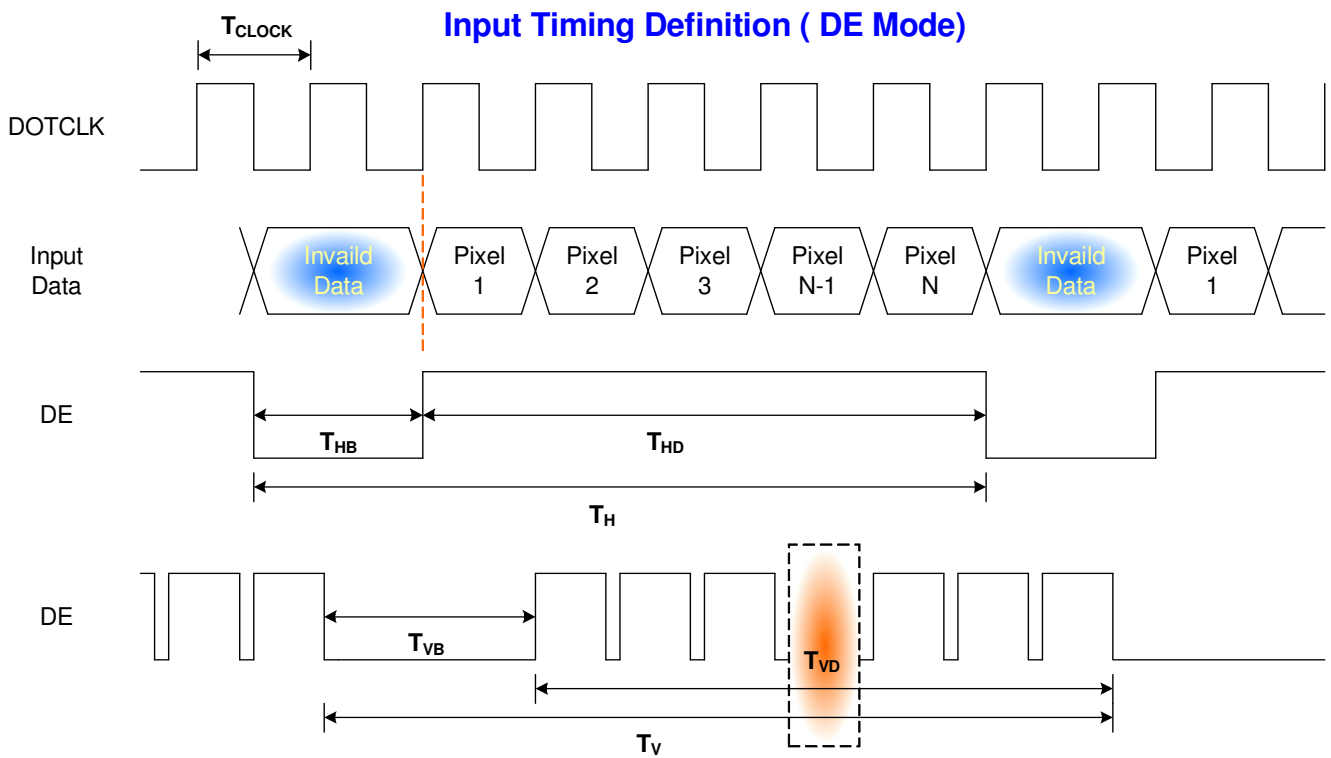

6.5 Power ON/OFF Sequence

VDD power on/off sequence is as follows. Interface signals are also shown in the chart. Signals from any system shall be Hi-Z state or low level when VDD is off

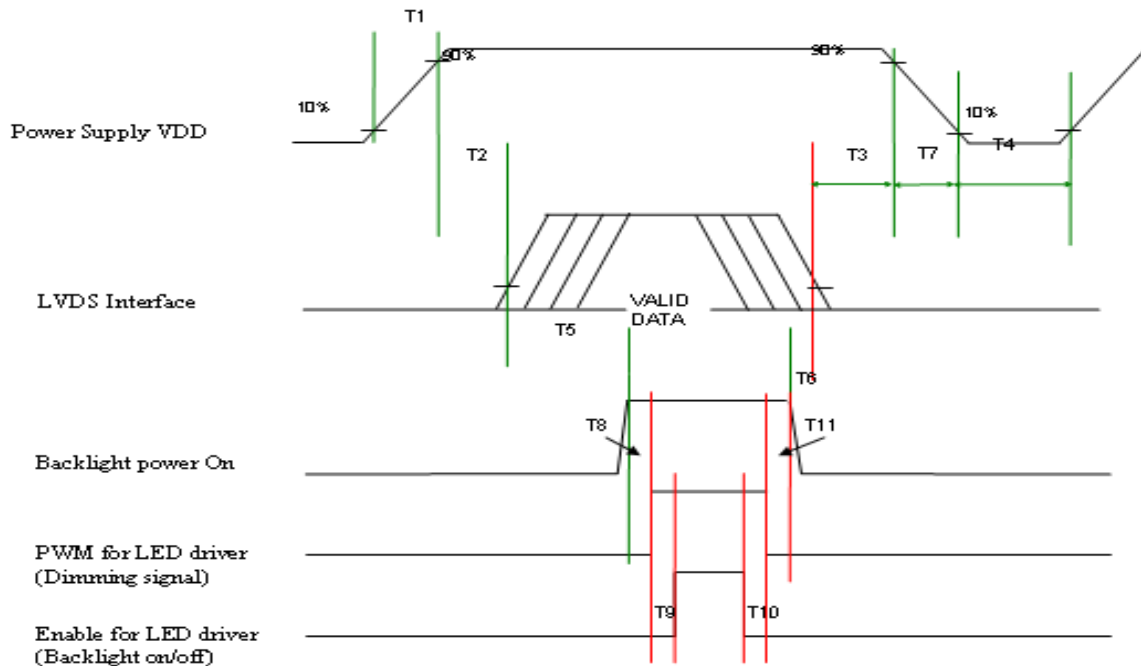

Parameter	Value			Units
	Min.	Typ.	Max.	
T1	0.5	-	10	(ms)
T2	5	-	50	(ms)
T3	0.5	-	50	(ms)
T4	400	-	-	(ms)
T5	200	-	-	(ms)
T6	200	-	-	(ms)
T7	0	-	10	(ms)
T8	10	---	---	(ms)
T9	10	---	---	(ms)
T10	0	---	---	(ms)
T11	10	---	---	(ms)



7. Connector Description

Physical interface is described as for the connector on module.

These connectors are capable of accommodating the following signals and will be following components.

7.1 TFT LCD Module

Connector Name / Designation	For Signal Connector
Manufacturer	IPEX or compatible
Type / Part Number	IPEX 20455-040E-12
Mating Housing/Part Number	IPEX 20453-040T-11



8. LED Driving Specification

8.1 Connector Description

It is a integrative interface and comibe into LVDS connector. The type and mating refer to section 7.

8.2 Pin Assignment

Ref. to 6.3

9. Vibration and Shock Test

9.1 Vibration Test

Test Spec:

- Test method: Non-Operation
- Acceleration: 1.5 G , Half sine pulse
- Frequency: 10 - 500Hz Sine wave
- Sweep: 30 Minutes each Axis (X, Y, Z)

9.2 Shock Test Spec:

Test Spec:

- Test method: Non-Operation
- Acceleration: 240 G , Half sine pulse
- Active time: 2 ms
- Pulse: X,Y,Z .one time for each side



10. Reliability

Items	Required Condition	Note
Temperature Humidity Bias	Ta= 40°C, 90%RH, 300h	
High Temperature Operation	Ta= 50°C, Dry, 300h	
Low Temperature Operation	Ta= 0°C, 300h	
High Temperature Storage	Ta= 60°C, 300h	
Low Temperature Storage	Ta= -20°C, 300h	
Thermal Shock Test	Ta=-20°C to 60°C, Duration at 30 min, 100 cycles	
ESD	Contact : ±8 KV Air : ±15 KV	Note 1

Note1: According to EN 61000-4-2 , ESD class B: Some performance degradation allowed. No data lost
. Self-recoverable. No hardware failures.

Remark: MTBF (Excluding the LED): 30,000 hours with a confidence level 90%

11. Mechanical Characteristics

11.1 LCM Outline Dimension

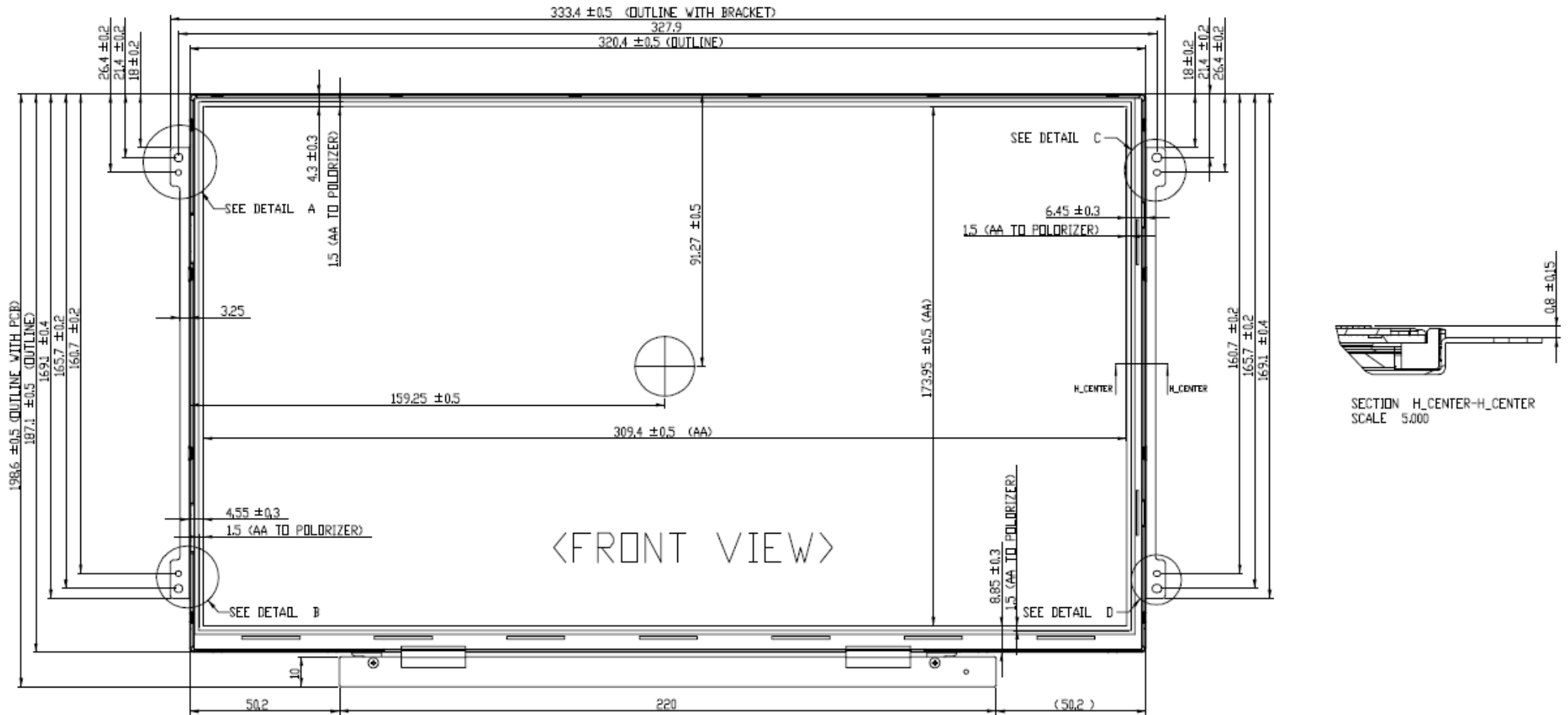

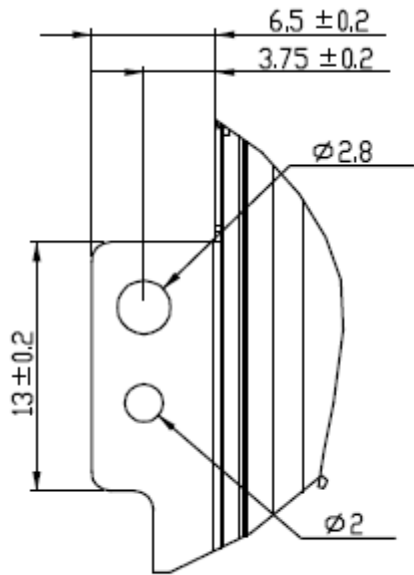

DETAIL A
SCALE 3.000

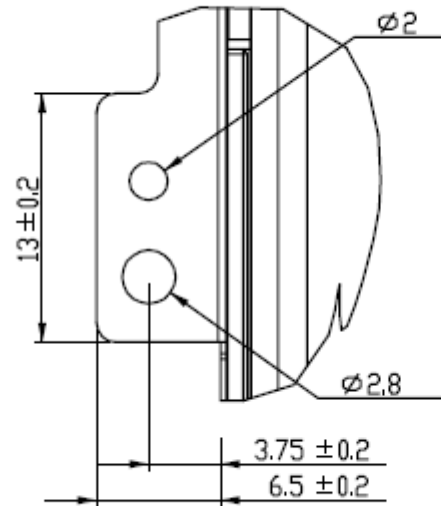

DETAIL B
SCALE 3.000

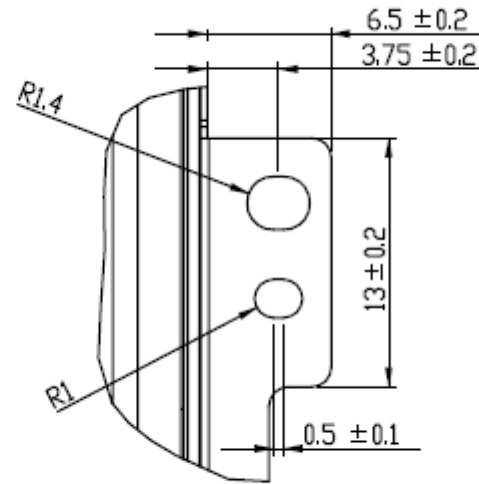

DETAIL C
SCALE 3.000

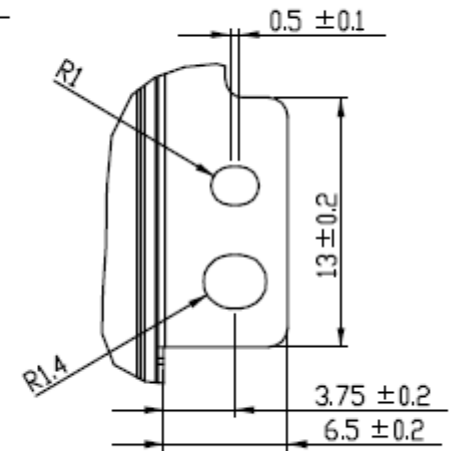

DETAIL D
SCALE 3.000

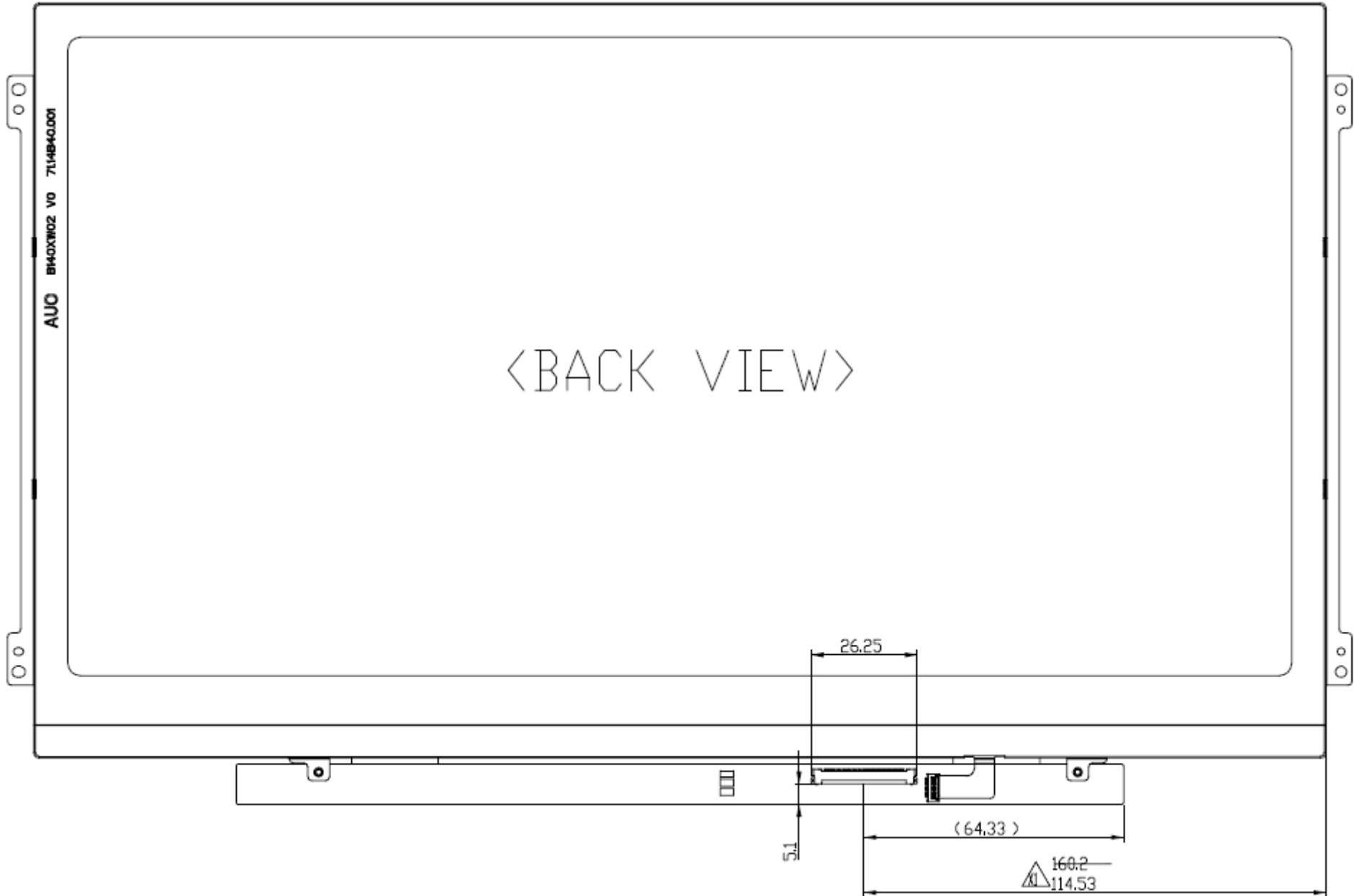







Product Specification

AU OPTRONICS CORPORATION

12. Shipping and Package

12.1 Shipping Label Format

	Manufactured xxxxx Model No: B140XW02 V0 AU Optronics 0AXXG MADE IN CHINA (S1) HW: 0A FW:1	  
---	---	---



12.2 Carton package

TBD

12.3 Shipping package of palletizing sequence

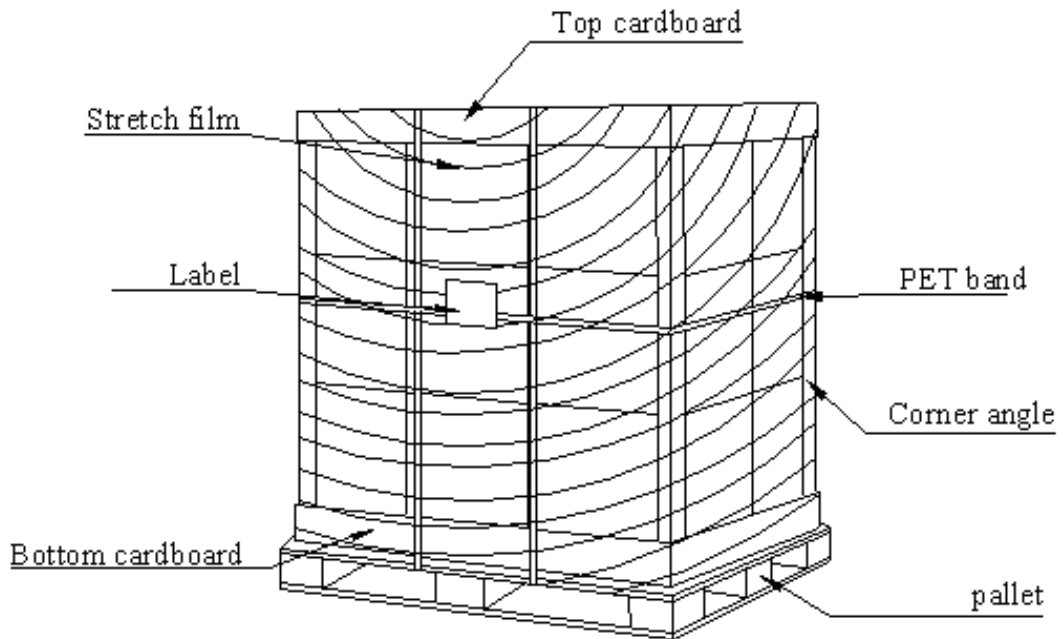

13. Appendix: EDID description

TBD