

# mass integrated

global part distribution • product lifecycle partner  
excess inventory management • value-ad service provider



Data sheet provided by Mass Integrated

[massintegrated.com](http://massintegrated.com) • [displayalliance.com](http://displayalliance.com)

Please call +1.978.465.6190  
Email: [sales@massintegrated.com](mailto:sales@massintegrated.com)



ISO 9001: 2008

Mass Integrated complies with all DMCA takedown notices. Please send a formal DMCA Takedown Notice to Mass Integrated Systems, Inc. • 18 Henry Graf Jr. Road, Unit 1 • Newburyport, MA 01950.



# Product Specification

AU OPTRONICS CORPORATION

( V ) Preliminary Specification

( ) Final Specification

<b>Module</b>	<b>14.0" (13.97") HD 16:9 Color TFT-LCD with LED Backlight design</b>
<b>Model Name</b>	<b>B140XW03 V0 (0A)</b>
<b>Note</b> (  )	<b><i>LED Backlight with driving circuit design</i></b>

<b>Customer</b>	<b>Date</b>
<b>Checked &amp; Approved by</b>	<b>Date</b>
Note: This Specification is subject to change without notice.	

<b>Approved by</b>	<b>Date</b>
<u>Bonnie Chen</u>	<u>07/23/2009</u>
<b>Prepared by</b>	<b>Date</b>
<u>Jonken Fan</u>	<u>07/23/2009</u>
<b>NBBU Marketing Division AU Optronics corporation</b>	



## Contents

<b>1. Handling Precautions .....</b>	<b>4</b>
<b>2. General Description .....</b>	<b>5</b>
2.1 General Specification.....	5
2.2 Optical Characteristics.....	6
<b>3. Functional Block Diagram.....</b>	<b>11</b>
<b>4. Absolute Maximum Ratings.....</b>	<b>12</b>
4.1 Absolute Ratings of TFT LCD Module .....	12
4.2 Absolute Ratings of Environment.....	12
<b>5. Electrical Characteristics .....</b>	<b>13</b>
5.1 TFT LCD Module.....	13
5.2 Backlight Unit.....	15
<b>6. Signal Interface Characteristic.....</b>	<b>16</b>
6.1 Pixel Format Image.....	16
6.2 The Input Data Format .....	17
6.3 Integration Interface Requirement .....	18
6.4 Interface Timing.....	20
<b>7. Panel Reliability Test .....</b>	<b>22</b>
7.1 Vibration Test.....	22
7.2 Shock Test.....	22
7.3 Reliability Test.....	22
<b>8. Mechanical Characteristics .....</b>	<b>23</b>
8.1 LCM Outline Dimension .....	23
<b>9. Shipping and Package .....</b>	<b>25</b>
9.1 Shipping Label Format.....	25
9.2 Carton Package.....	26
9.3 Shipping Package of Palletizing Sequence .....	26
<b>10. Appendix: EDID Description .....</b>	<b>27</b>



## 1. Handling Precautions

- 1) Since front polarizer is easily damaged, pay attention not to scratch it.
- 2) Be sure to turn off power supply when inserting or disconnecting from input connector.
- 3) Wipe off water drop immediately. Long contact with water may cause discoloration or spots.
- 4) When the panel surface is soiled, wipe it with absorbent cotton or other soft cloth.
- 5) Since the panel is made of glass, it may break or crack if dropped or bumped on hard surface.
- 6) Since CMOS LSI is used in this module, take care of static electricity and insure human earth when handling.
- 7) Do not open nor modify the Module Assembly.
- 8) Do not press the reflector sheet at the back of the module to any directions.
- 9) At the insertion or removal of the Signal Interface Connector, be sure not to rotate nor tilt the Interface Connector of the TFT Module.
- 11) After installation of the TFT Module into an enclosure (Notebook PC Bezel, for example), do not twist nor bend the TFT Module even momentarily. At designing the enclosure, it should be taken into consideration that no bending/twisting forces are applied to the TFT Module from outside. Otherwise the TFT Module may be damaged.
- 12) Small amount of materials having no flammability grade is used in the LCD module. The LCD module should be supplied by power complied with requirements of Limited Power Source (IEC60950 or UL1950), or be applied exemption.
- 13) Disconnecting power supply before handling LCD modules, it can prevent electric shock, DO NOT TOUCH the electrode parts, cables, connectors and LED circuit part of TFT module that a LED light bar build in as a light source of back light unit. It can prevent electronic breakdown.

## 2. General Description

B140XW03 V0 is a Color Active Matrix Liquid Crystal Display composed of a TFT LCD panel, a driver circuit, and LED backlight system. The screen format is intended to support the 16:9 HD, 1366(H) x768(V) screen and 262k colors (RGB 6-bits data driver) with LED backlight driving circuit. All input signals are LVDS interface compatible.

B140XW03 V0 is designed for a display unit of notebook style personal computer and industrial machine.

### 2.1 General Specification

The following items are characteristics summary on the table at 25 °C condition:

Items	Unit	Specifications			
Screen Diagonal	[mm]	354, 14.0"(13.97")			
Active Area	[mm]	309.399 x 173.952			
Pixels H x V		1366 x 3(RGB) x 768			
Pixel Pitch	[mm]	0.2265 x 0.2265			
Pixel Format		B.G.R. Vertical Stripe			
Display Mode		Normally White			
White Luminance (I <sub>LED</sub> =20mA) (Note: I <sub>LED</sub> is LED current)	[cd/m <sup>2</sup> ]	200 typ. (5 points average) 170 min. (5 points average)			
Luminance Uniformity		1.25 max. (5 points)			
Contrast Ratio		500 typ			
Response Time	[ms]	8 typ / 16 Max			
Nominal Input Voltage VDD	[Volt]	+3.3 typ.			
Power Consumption	[Watt]	TBD			
Weight	[Grams]	320 max.			
Physical Size <b>Include bracket</b>	[mm]		Min.	Typ.	Max.
		Length	319.9	320.4	320.9
		Width	204.6	205.1	205.6
		Thickness	-	-	3.6
Electrical Interface		1 channel LVDS			
Glass Thickness	[mm]	0.5			
Surface Treatment		Glare, Hardness 3H,			



# Product Specification

AU OPTRONICS CORPORATION

Support Color		262K colors ( RGB 6-bit )
Temperature Range Operating Storage (Non-Operating)	[°C] [°C]	0 to +50 -20 to +60
RoHS Compliance		RoHS Compliance

## 2.2 Optical Characteristics

The optical characteristics are measured under stable conditions at 25°C (Room Temperature) :

Item	Symbol	Conditions	Min	Typ	Max	Unit	Notes
<b>White Luminance</b> $I_{LED}=20mA$		<b>5 points average</b>	<b>170</b>	<b>200</b>	-	cd/m <sup>2</sup>	1, 4,
<b>Viewing Angle</b>	$\theta_R$	<b>Horizontal (Right CR = 10 (Left)</b>	<b>40</b>	<b>45</b>	-	degree	4, 9
	$\theta_L$		<b>40</b>	<b>45</b>	-		
	$\phi_H$	<b>Vertical (Upper CR = 10 (Lower)</b>	<b>10</b>	<b>15</b>	-		
	$\phi_L$		<b>30</b>	<b>35</b>	-		
<b>Luminance Uniformity</b>	$\delta_{5P}$	<b>5 Points</b>	-	-	<b>1.2</b>		1, 3,
<b>Luminance Uniformity</b>	$\delta_{13P}$	<b>13 Points</b>	-	-	<b>1.6</b>		2, 3,
<b>Contrast Ratio</b>	<b>CR</b>		<b>400</b>	<b>500</b>	-		4, 6
<b>Cross talk</b>	%		-	-	<b>4</b>		4, 7
<b>Response Time</b>	$T_r$	<b>Rising</b>	-	<b>2</b>	-	msec	4, 8
	$T_f$	<b>Falling</b>	-	<b>6</b>	-		
	$T_{RT}$	<b>Rising + Falling</b>	-	<b>8</b>	<b>16</b>		
<b>Color / Chromaticity Coordinates</b>	<b>Red</b>	<b>Rx</b>	<b>CIE 1931</b>	TBD	TBD	TBD	4
		<b>Ry</b>		TBD	TBD	TBD	
	<b>Green</b>	<b>Gx</b>		TBD	TBD	TBD	
		<b>Gy</b>		TBD	TBD	TBD	
	<b>Blue</b>	<b>Bx</b>		TBD	TBD	TBD	
		<b>By</b>		TBD	TBD	TBD	
	<b>White</b>	<b>Wx</b>		<b>0.26</b>	<b>0.31</b>	<b>0.36</b>	
		<b>Wy</b>		<b>0.27</b>	<b>0.32</b>	<b>0.37</b>	
<b>NTSC</b>	%		<b>42</b>	<b>45</b>	-		

**Note 1:** 5 points position (Ref: Active area)

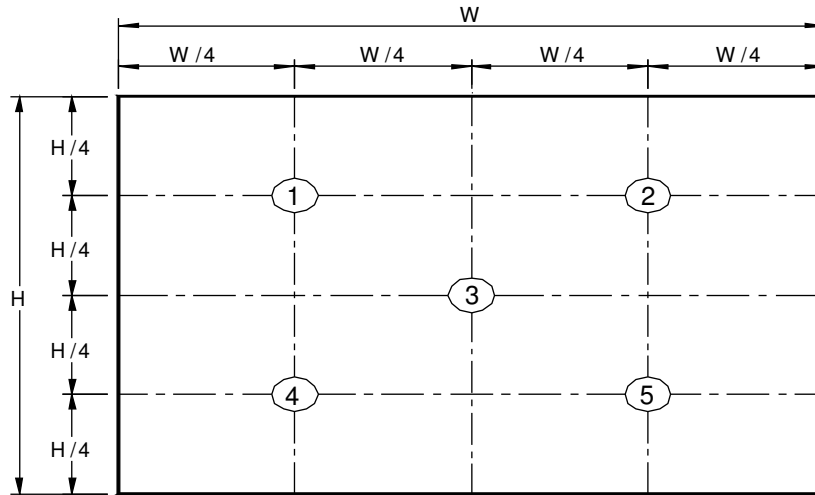

**Note 2:** 13 points position (Ref: Active area)

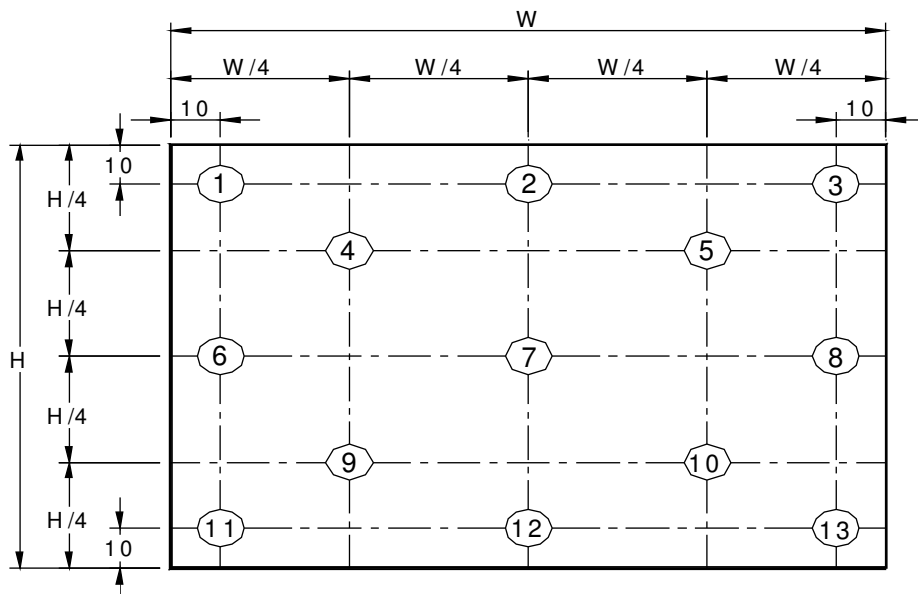

**Note 3:** The luminance uniformity of 5 or 13 points is defined by dividing the maximum luminance values by the minimum test point luminance

$$\delta_{W5} = \frac{\text{Maximum Brightness of five points}}{\text{Minimum Brightness of five points}}$$

$$\delta_{W13} = \frac{\text{Maximum Brightness of thirteen points}}{\text{Minimum Brightness of thirteen points}}$$

**Note 4:** Measurement method

The LCD module should be stabilized at given temperature for 30 minutes to avoid abrupt temperature change during measuring. In order to stabilize the luminance, the measurement should be executed after lighting Backlight for 30

for 30 minutes in a stable, windless and dark room, and it should be measured in the center of screen.

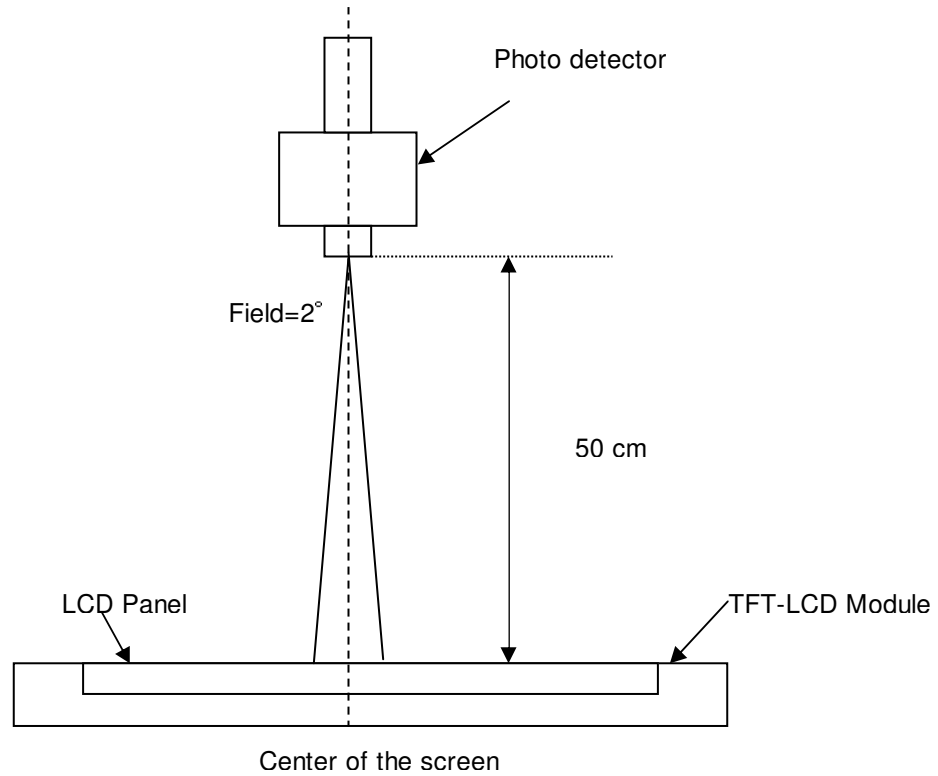

**Note 5 :** Definition of Average Luminance of White ( $Y_L$ ):

Measure the luminance of gray level 63 at 5 points ,  $Y_L = [L (1)+ L (2)+ L (3)+ L (4)+ L (5)] / 5$

$L (x)$  is corresponding to the luminance of the point X at Figure in Note (1).

**Note 6 :** Definition of contrast ratio:

Contrast ratio is calculated with the following formula.

$$\text{Contrast ratio (CR)} = \frac{\text{Brightness on the "White" state}}{\text{Brightness on the "Black" state}}$$

**Note 7 :** Definition of Cross Talk (CT)

$$CT = | Y_B - Y_A | / Y_A \times 100 (\%)$$

Where

$Y_A$  = Luminance of measured location without gray level 0 pattern (cd/m<sup>2</sup>)

$Y_B$  = Luminance of measured location with gray level 0 pattern (cd/m<sup>2</sup>)

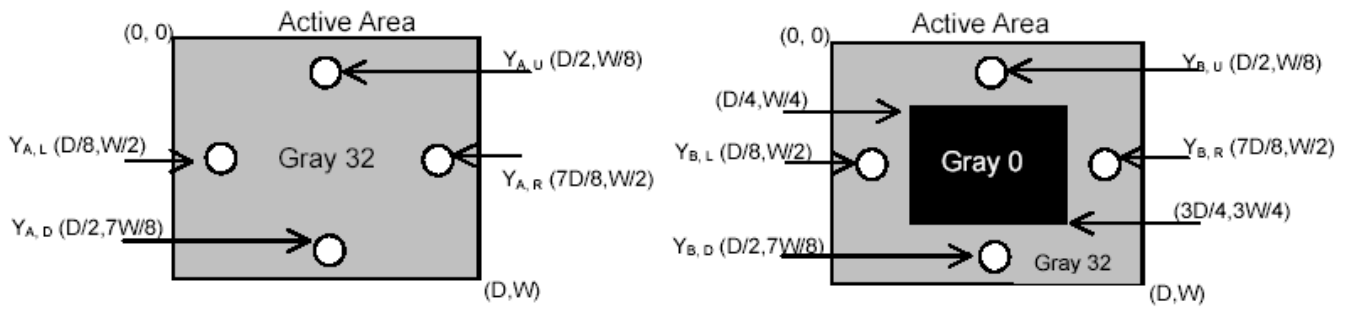

**Note 8:** Definition of response time:

The output signals of BM-7 or equivalent are measured when the input signals are changed from "Black" to "White" (falling time) and from "White" to "Black" (rising time), respectively. The response time interval between the 10% and 90% of amplitudes. Refer to figure as below.

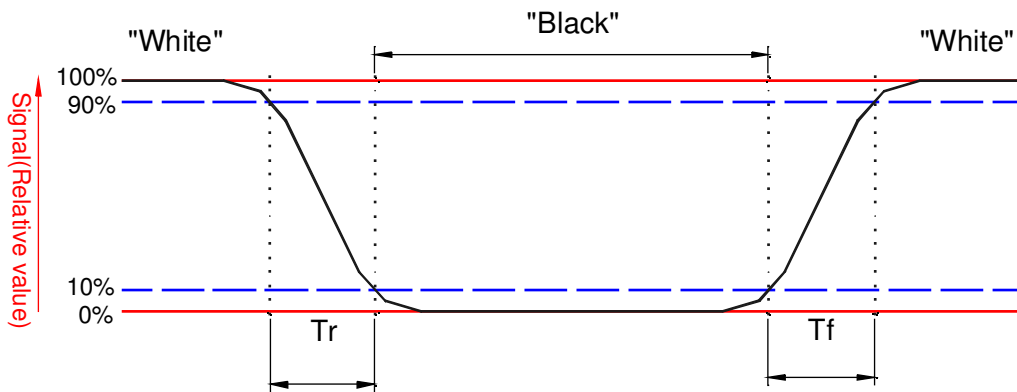

**Note 9.** Definition of viewing angle

Viewing angle is the measurement of contrast ratio  $\geq 10$ , at the screen center, over a  $180^\circ$  horizontal and  $180^\circ$  vertical range (off-normal viewing angles). The  $180^\circ$  viewing angle range is broken down as follows;  $90^\circ$  ( $\theta$ ) horizontal left and right and  $90^\circ$  ( $\phi$ ) vertical, high (up) and low (down). The measurement direction is typically perpendicular to the display surface with the screen rotated about its center to develop the desired measurement viewing angle.

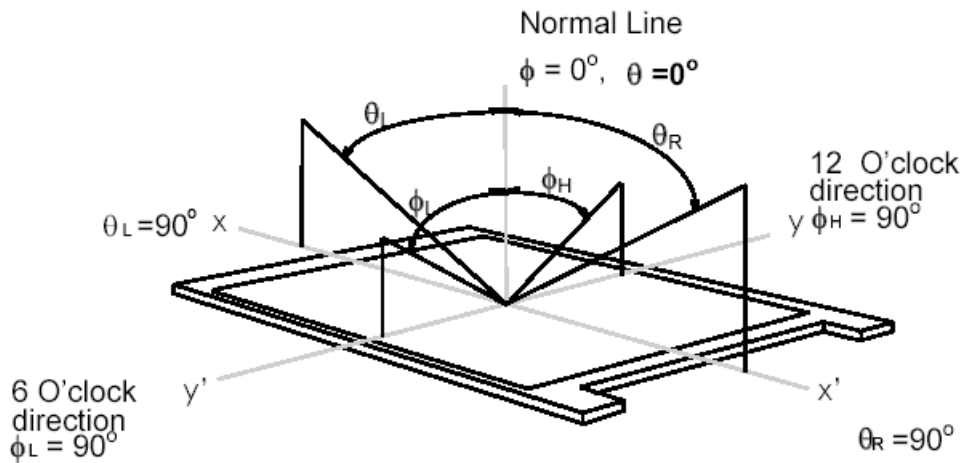

## 3. Functional Block Diagram

The following diagram shows the functional block of the 14.0 inches wide Color TFT/LCD 40 Pin one channel Module

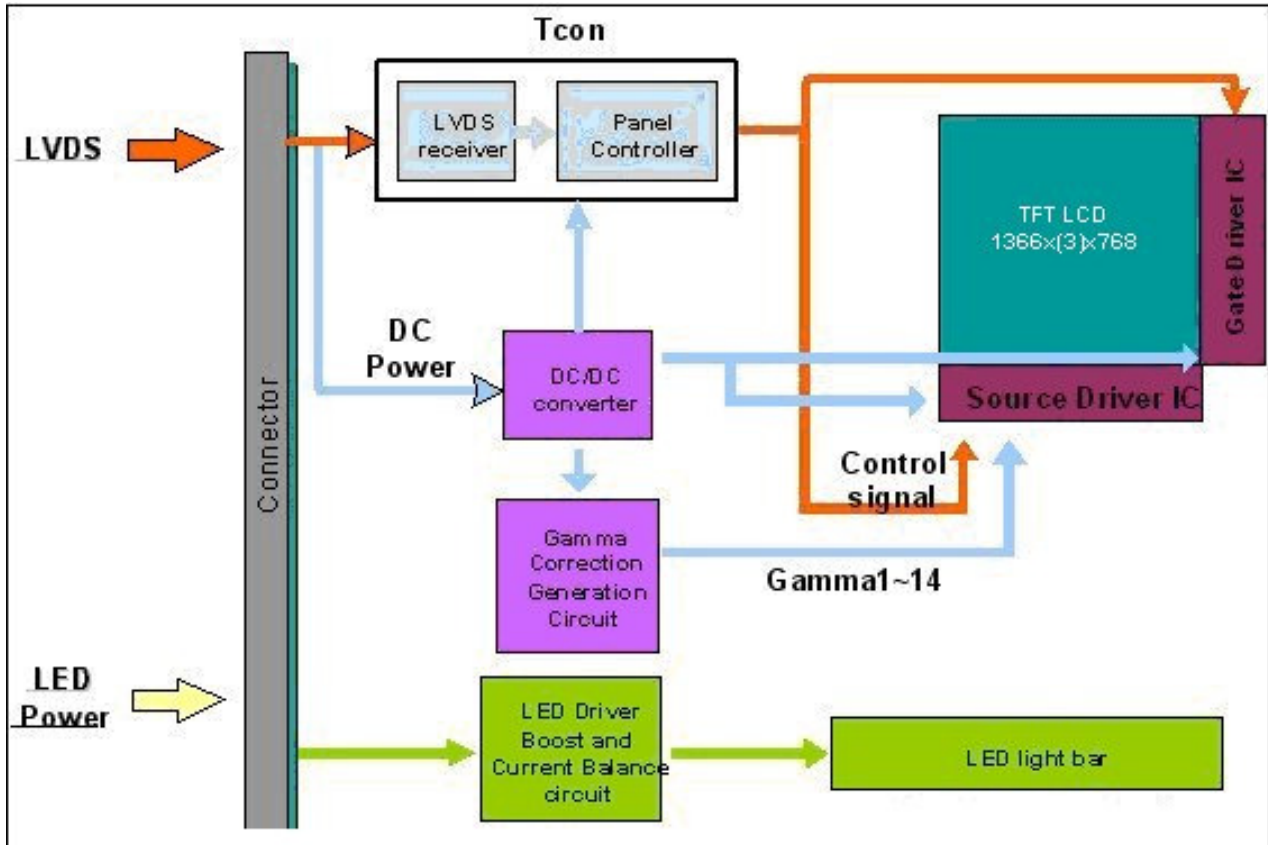

## 4. Absolute Maximum Ratings

An absolute maximum rating of the module is as following:

### 4.1 Absolute Ratings of TFT LCD Module

Item	Symbol	Min	Max	Unit	Conditions
Logic/LCD Drive Voltage	Vin	-0.3	+4.0	[Volt]	Note 1,2

### 4.2 Absolute Ratings of Environment

Item	Symbol	Min	Max	Unit	Conditions
Operating Temperature	TOP	0	+50	[°C]	Note 4
Operation Humidity	HOP	5	95	[%RH]	Note 4
Storage Temperature	TST	-20	+60	[°C]	Note 4
Storage Humidity	HST	5	95	[%RH]	Note 4

Note 1: At Ta (25°C )

Note 2: Permanent damage to the device may occur if exceed maximum values

Note 3: LED specification refer to section 5.2

Note 4: For quality performance, please refer to AUO IIS (Incoming Inspection Standard).

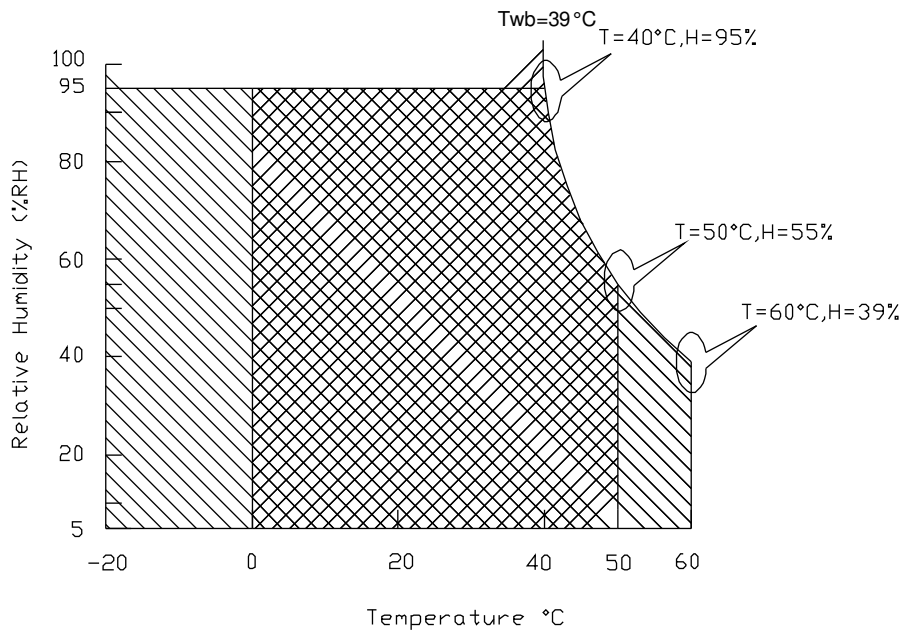

Operating Range 

Storage Range  + 

## 5. Electrical Characteristics

### 5.1 TFT LCD Module

#### 5.1.1 Power Specification

Input power specifications are as follows;

The power specification are measured under 25°C and frame frequency under 60Hz

Symble	Parameter	Min	Typ	Max	Units	Note
VDD	Logic/LCD Drive Voltage	3.0	3.3	3.6	[Volt]	
PDD	VDD Power	-	-	1	[Watt]	Note 1
IDD	IDD Current	-	-	333	[mA]	Note 1
IRush	Inrush Current	-	-	2000	[mA]	Note 2
VDDrp	Allowable Logic/LCD Drive Ripple Voltage	-	-	100	[mV] p-p	

Note 1 : Maximum Measurement Condition : Black Pattern at 3.3V driving voltage. ( $P_{max} = V_{3.3} \times I_{black}$ )

Note 2 : Measure Condition

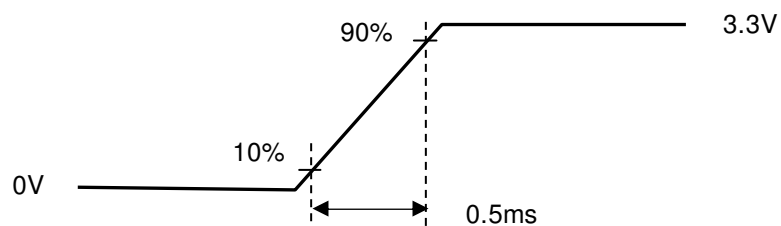
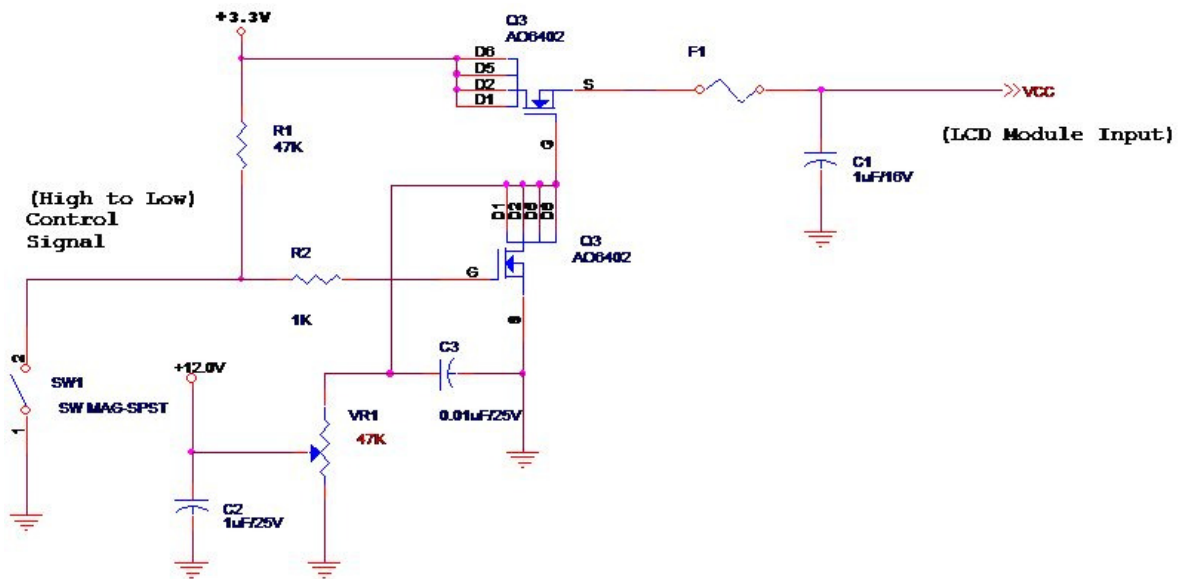

Vin rising time

## 5.1.2 Signal Electrical Characteristics

Input signals shall be low or High-impedance state when VDD is off.

Signal electrical characteristics are as follows;

Parameter	Condition	Min	Max	Unit
$V_{th}$	Differential Input High Threshold ( $V_{cm}=+1.2V$ )	-	100	[mV]
$V_{tl}$	Differential Input Low Threshold ( $V_{cm}=+1.2V$ )	-100	-	[mV]
$V_{ID}$	Differential Input Voltage	100	600	[mV]
$V_{cm}$	Differential Input Common Mode Voltage	1.125	1.375	[V]

Note: LVDS Signal Waveform

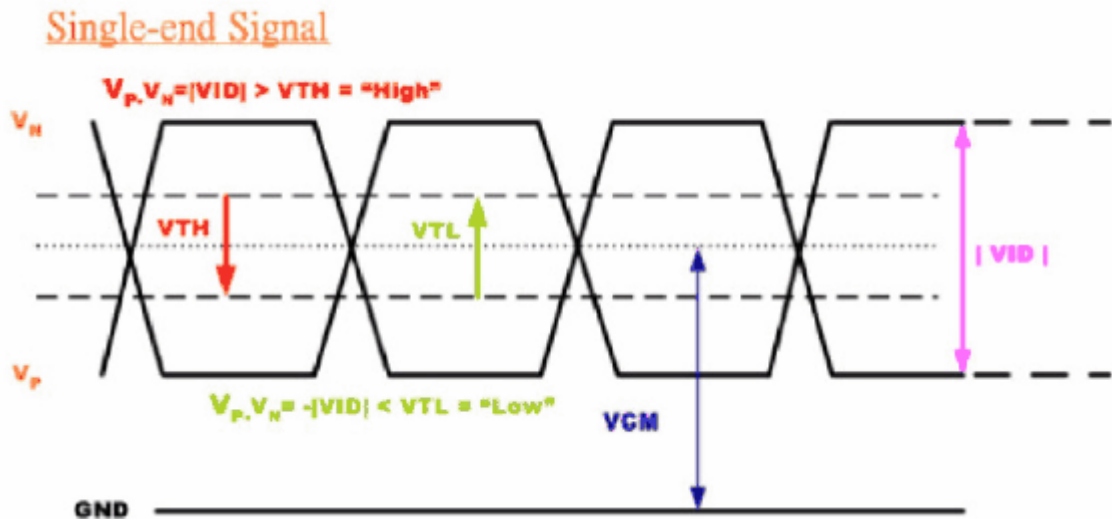



## 5.2 Backlight Unit

### 5.2.1 LED characteristics

Parameter	Symbol	Min	Typ	Max	Unit	Condition
Backlight Power Consumption	PLED	-	-	TBD	[Watt]	(Ta=25°C), Note 1 Vin =12V
LED Life-Time	N/A	12,000	-	-	Hour	(Ta=25°C), Note 2 If=20 mA

**Note 1:** Calculator value for reference  $P_{LED} = VF$  (Normal Distribution) \*  $I_F$  (Normal Distribution) / Efficiency

**Note 2:** The LED life-time define as the estimated time to 50% degradation of initial luminous.

### 5.2.2 Backlight input signal characteristics

Parameter	Symbol	Min	Typ	Max	Units	Remark
LED Power Supply	VLED	7.0	12.0	21.0	[Volt]	Define as Connector Interface (Ta=25°C)
LED Enable Input High Level	VLED_EN	2.5	-	5.5	[Volt]	
LED Enable Input Low Level		-	-	0.8	[Volt]	
PWM Logic Input High Level	VPWM_EN	2.5	-	5.0	[Volt]	
PWM Logic Input Low Level		-	-	0.8	[Volt]	
PWM Input Frequency	FPWM	100	-	20K	Hz	
PWM Duty Ratio	Duty	5	--	100	%	

## 6. Signal Interface Characteristic

### 6.1 Pixel Format Image

Following figure shows the relationship of the input signals and LCD pixel format.

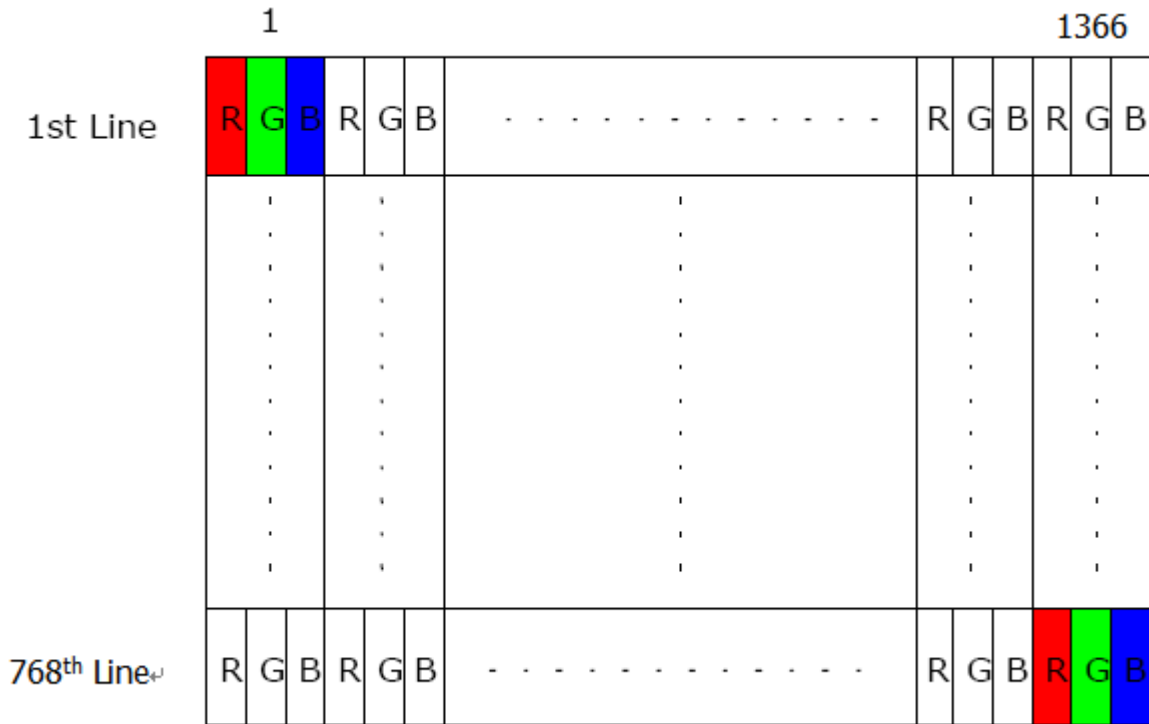

## 6.2 The Input Data Format

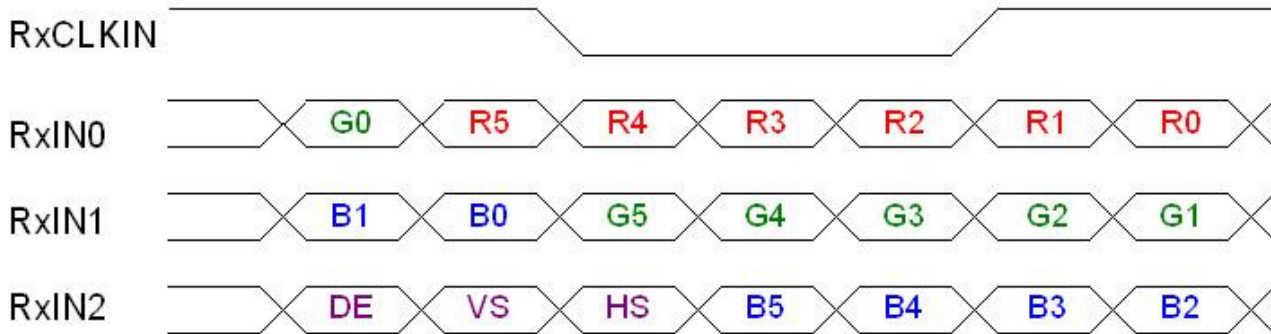

Signal Name	Description	
R5 R4 R3 R2 R1 R0	Red Data 5 (MSB) Red Data 4 Red Data 3 Red Data 2 Red Data 1 Red Data 0 (LSB)	Red-pixel Data Each red pixel's brightness data consists of these bits pixel data.
G5 G4 G3 G2 G1 G0	Green Data 5 (MSB) Green Data 4 Green Data 3 Green Data 2 Green Data 1 Green Data 0 (LSB)	Green-pixel Data Each green pixel's brightness data consists of the 6 bits pixel data.
B5 B4 B3 B2 B1 B0	Blue Data 5 (MSB) Blue Data 4 Blue Data 3 Blue Data 2 Blue Data 1 Blue Data 0 (LSB)	Blue-pixel Data Each blue pixel's brightness data consists of these bits pixel data.
RxCLKIN	Data Clock	The signal is used to strobe the pixel data and DE signals. All pixel data shall be valid at the falling edge when the DE signal is high.
DE	Display Timing	This signal is strobed at the falling edge of RxCLKIN. When the signal is high, the pixel data shall be valid to be displayed.
VS	Vertical Sync	The signal is synchronized to RxCLKIN .
HS	Horizontal Sync	The signal is synchronized to RxCLKIN .

Note: Output signals from any system shall be low or High-impedance state when VDD is off.

## 6.3 Integration Interface Requirement

### 6.3.1 Connector Description

Physical interface is described as for the connector on module.

These connectors are capable of accommodating the following signals and will be following components.

Connector Name / Designation	For Signal Connector
Manufacturer	IPEX or compatible
Type / Part Number	IPEX 20455-040E-12A or compatible
Mating Housing/Part Number	IPEX 20453-040T-11 or compatible

### 6.3.2 Pin Assignment

LVDS is a differential signal technology for LCD interface and high speed data transfer device.

B140XW03 V0		
P	Signal	Description
1	NC	No Connection (Reserve)
2	VDD	PowerSupply,3.3V(typical)
3	VDD	PowerSupply,3.3V(typical)
4	DVDD	DDC 3.3Vpower
5	NC	No Connection (Reserve)
6	SCL	DDC Clock
7	SDA	DDC Data
8	Rin0-	-LVDS differential data input(R0-R5,G0)
9	Rin0+	+LVDS differential data input(R0-R5,G0)
10	GND	Ground
11	Rin1-	-LVDS differential data input(G1-G5,B0-B1)
12	Rin1+	+LVDS differential data input(G1-G5,B0-B1)
13	GND	Ground
14	Rin2-	-LVDS differential data input(B2-B5,HS,VS,DE)
15	Rin2+	+LVDS differential data input(B2-B5,HS,VS,DE)
16	GND	Ground
17	ClkIN-	-LVDS differential clock input
18	ClkIN+	+LVDS differential clock input
19	CE_EN	Color Engine Control
20	NC	No Connection (Reserve)
21	NC	No Connection (Reserve)
22	GND	Ground
23	NC	No Connection (Reserve)

2	NC	No Connection (Reserve)
2	GND	Ground-Shield
2	NC	No Connection (Reserve)
2	NC	No Connection (Reserve)
2	GND	Ground-Shield
2	NC	No Connection (Reserve)
3	NC	No Connection (Reserve)
3	VLED_GN	LED Ground
3	VLED_GN	LED Ground
3	VLED_GN	LED Ground
3	NC	No Connection (Reserve)
3	PWM	System PWM Signal Input
3	LED_EN	LED enable pin(+3V Input)
3	ECR_EN	Dynamic Backlight Control (High Enable)
3	VLED	LED Power Supply 7V-21V
3	VLED	LED Power Supply 7V-21V
4	VLED	LED Power Supply 7V-21V

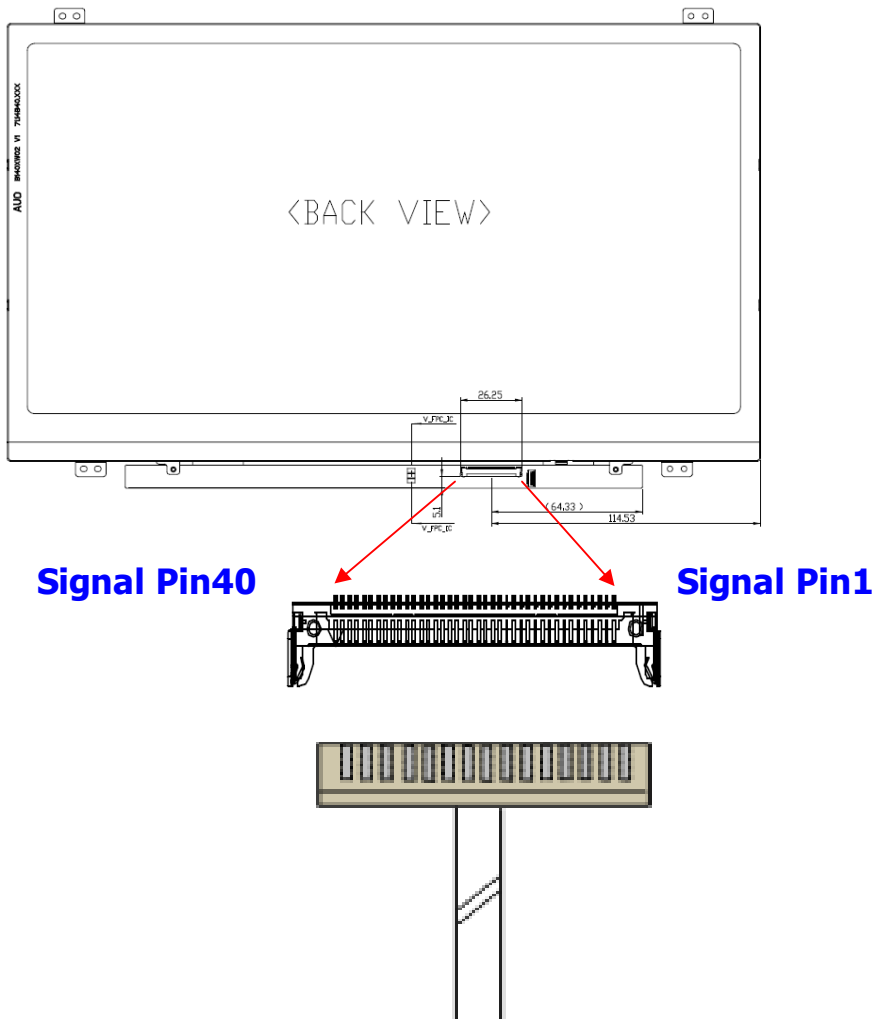

Note1: Input signals shall be low or High-impedance state when VDD is off.

## 6.4 Interface Timing

### 6.4.1 Timing Characteristics

Basically, interface timings should match the 1366x768 /60Hz manufacturing guide line timing.

Parameter	Symbol	Min.	Typ.	Max.	Unit
Frame Rate	-	-	60	-	Hz
Clock frequency	$1/T_{Clock}$	-	72	-	MHz
Vertical Section	Period	$T_V$	TBD	TBD	$T_{Line}$
	Active	$T_{VD}$	TBD		
	Blanking	$T_{VB}$	TBD	TBD	
Horizontal Section	Period	$T_H$	TBD	TBD	$T_{Clock}$
	Active	$T_{HD}$	TBD		
	Blanking	$T_{HB}$	TBD	TBD	

Note : DE mode only

### 6.4.2 Timing diagram

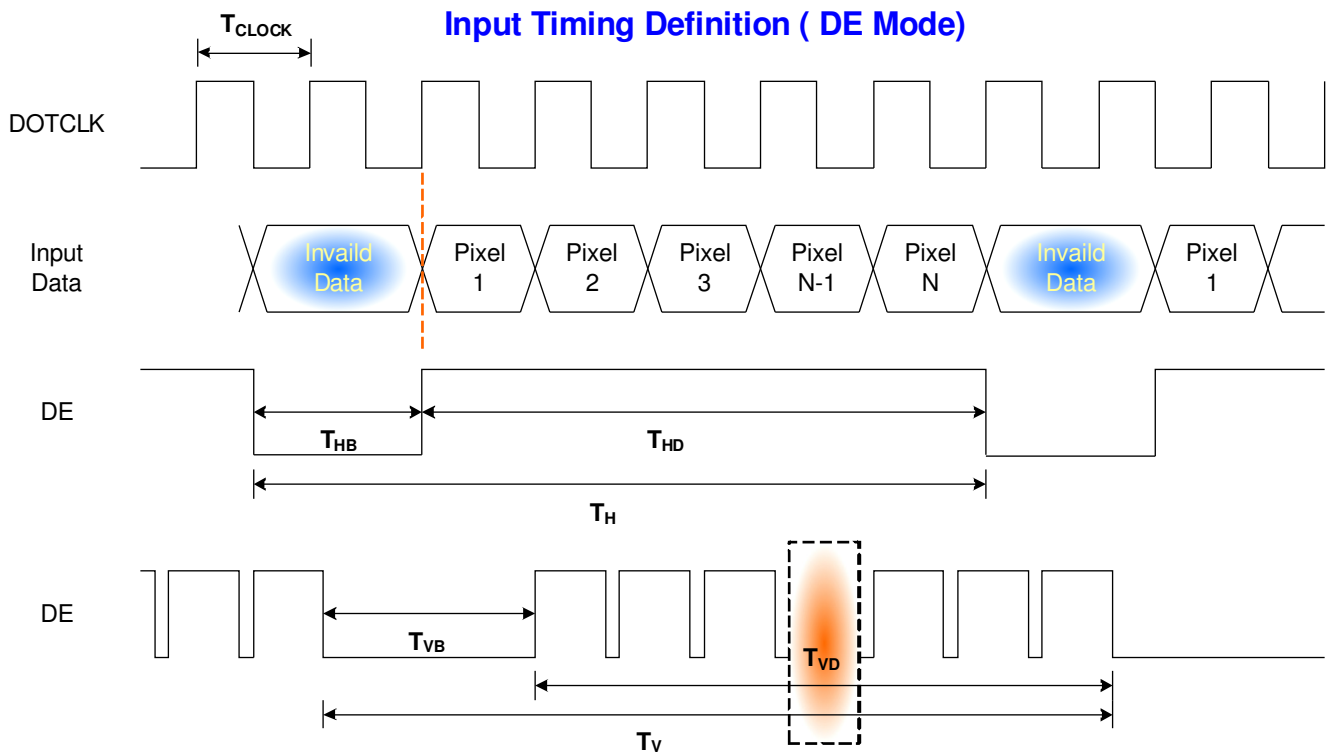

## 6.5 Power ON/OFF Sequence

Power on/off sequence is as follows. Interface signals and LED on/off sequence are also shown in the chart. Signals from any system shall be Hi-Z state or low level when VDD is off

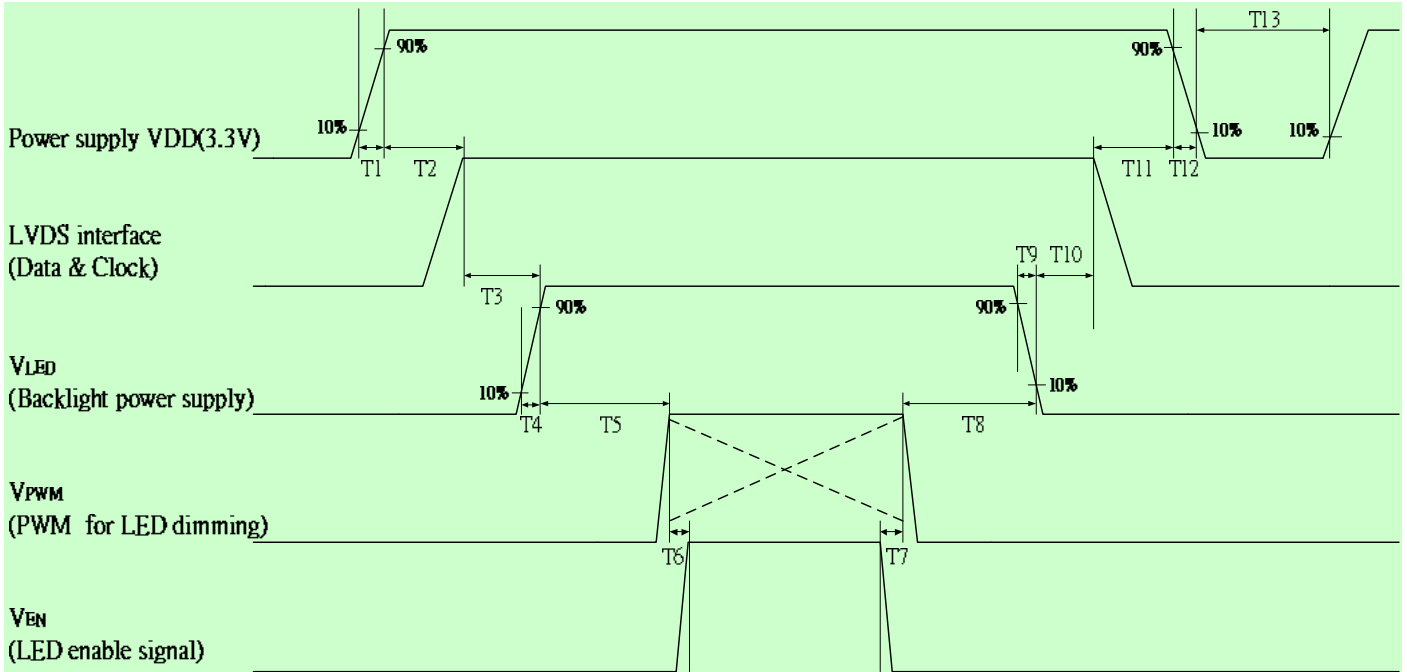

Power Sequence Timing				
Parameter	Value			Units
	Min.	Typ.	Max.	
T1	0.5	-	10	ms
T2	0	-	50	
T3	200	-	-	
T4	0.5	-	10	
T5	10	-	-	
T6	10	-	-	
T7	0	-	-	
T8	10	-	-	
T9	0	-	10	
T10	200	-	-	
T11	0	-	50	
T12	0	-	10	
T13	400	-	-	

Note: If T3, T5, T6 couldn't match above specifications, must request T3+T5+T6 > 200ms at least

## 7. Panel Reliability Test

### 7.1 Vibration Test

**Test Spec:**

- Test method: Non-Operation
- Acceleration: 1.5 G
- Frequency: 10 - 500Hz Random
- Sweep: 30 Minutes each Axis (X, Y, Z)

### 7.2 Shock Test

**Test Spec:**

- Test method: Non-Operation
- Acceleration: 220 G , Half sine wave
- Active time: 2 ms
- Pulse: X,Y,Z .one time for each side

### 7.3 Reliability Test

Items	Required Condition	Note
Temperature Humidity Bias	Ta= 40°C, 90%RH, 300h	
High Temperature Operation	Ta= 50°C, Dry, 300h	
Low Temperature Operation	Ta= 0°C, 300h	
High Temperature Stor	Ta= 60°C, 35%RH, 300h	
Low Temperature Stor	Ta= -20°C, 50%RH, 250h	
Thermal Shock Test	Ta=-20°C to 60°C, Duration at 30 min, 100 cycles	
ESD	Contact : ±8 KV Air : ±15 KV	Note 1

**Note1:** According to EN 61000-4-2 , ESD class B: Some performance degradation allowed. No data lost . Self-recoverable. No hardware failures.

**Remark:** MTBF (Excluding the LED): 30,000 hours with a confidence level 90%

## 8. Mechanical Characteristics

### 8.1 LCM Outline Dimension

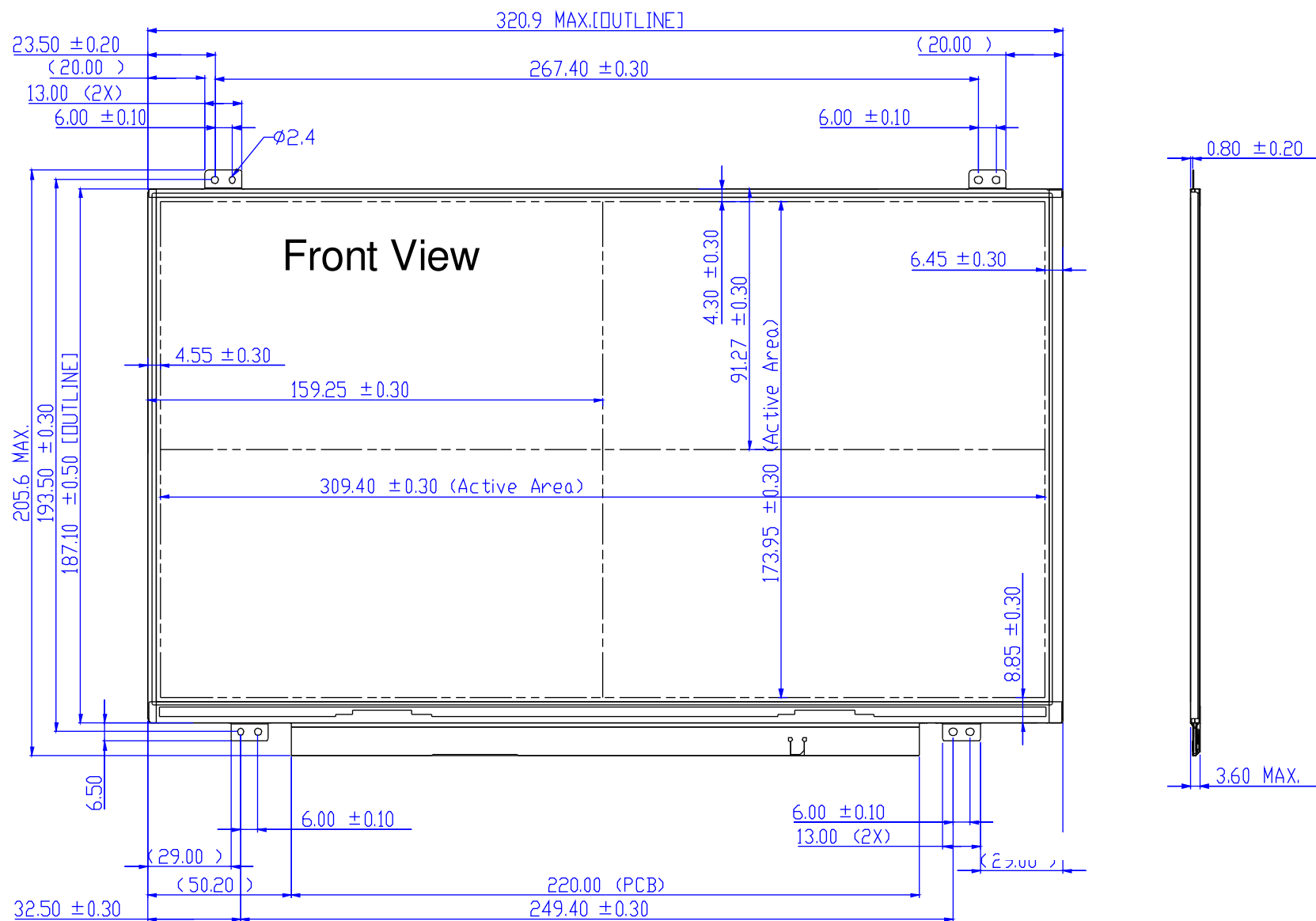

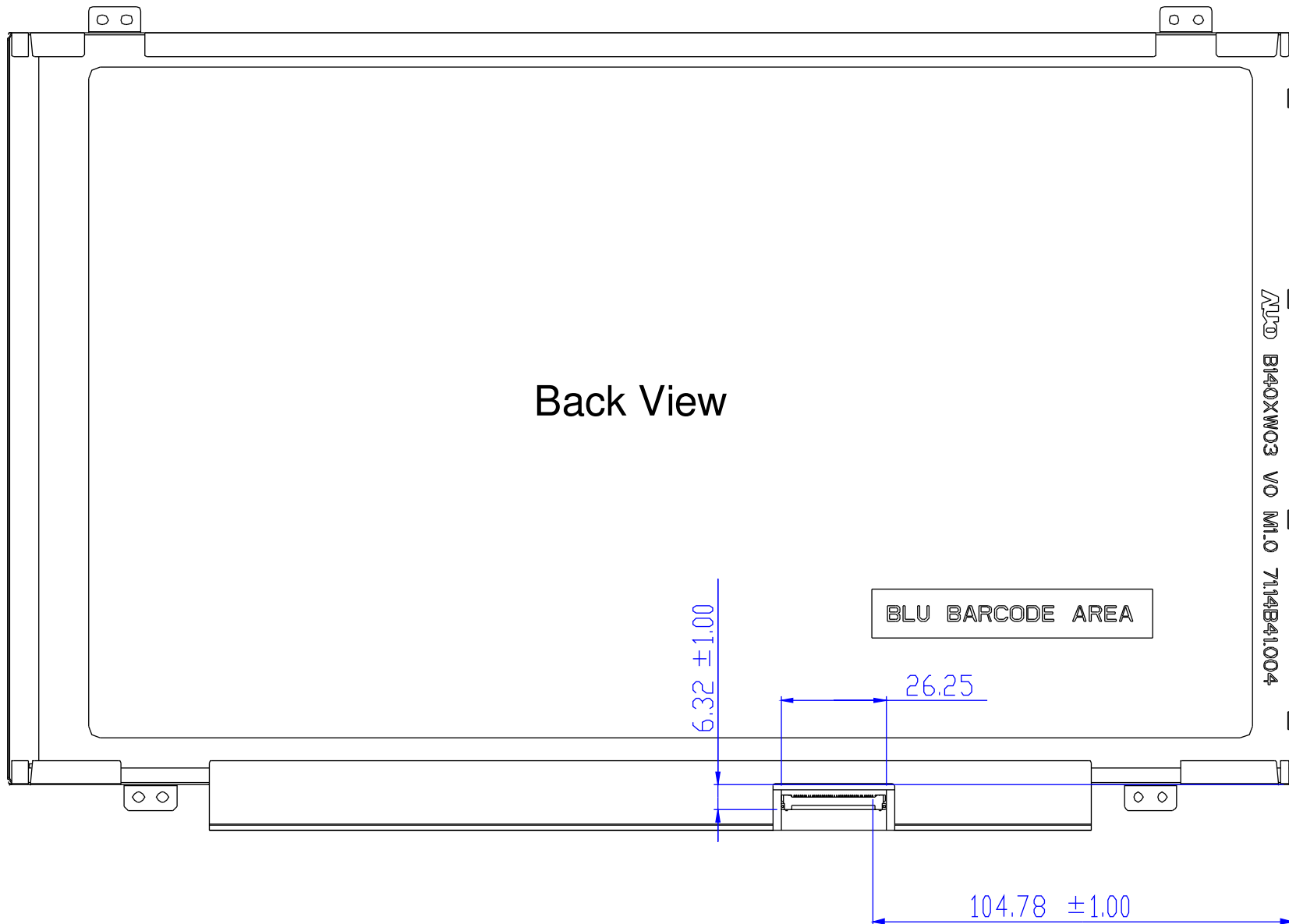

## 9. Shipping and Package

### 9.1 Shipping Label Format

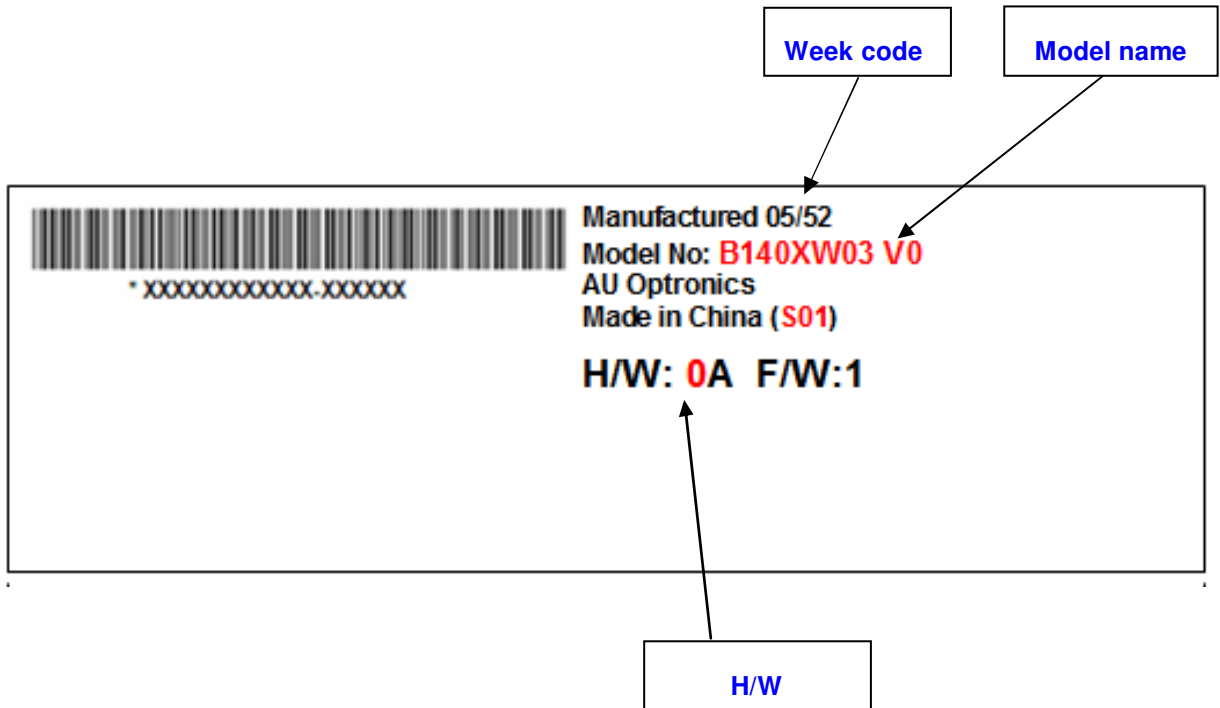

## 9.2 Carton Package

The outside dimension of carton is 455 (L)mm x 380 (W)mm x 355 (H)mm

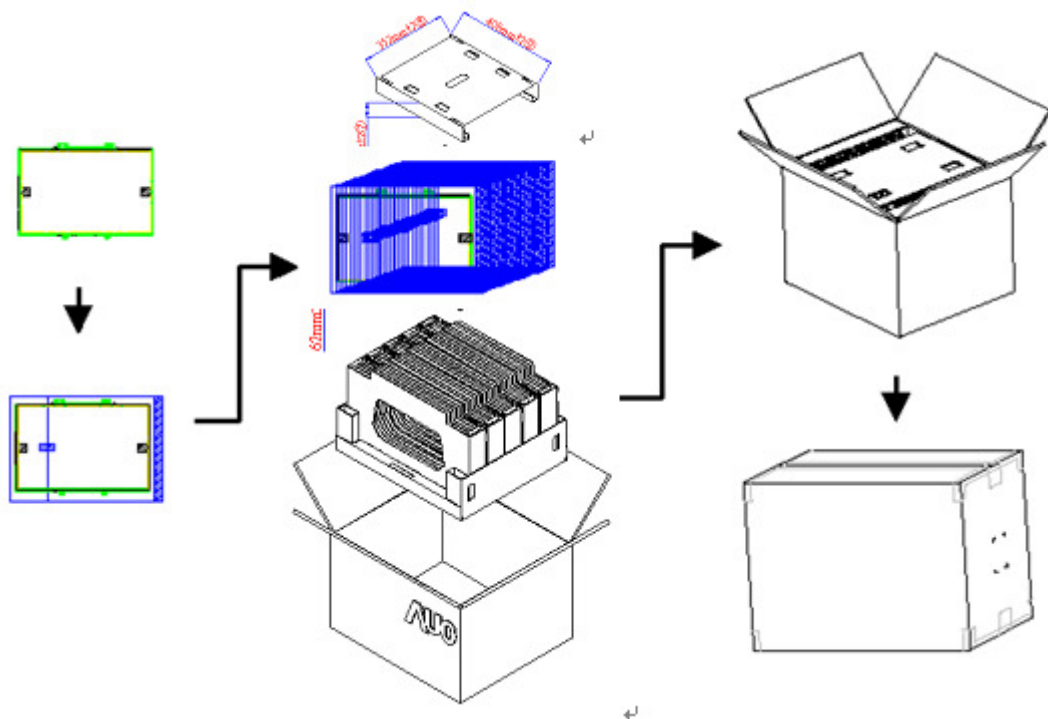

## 9.3 Shipping Package of Palletizing Sequence

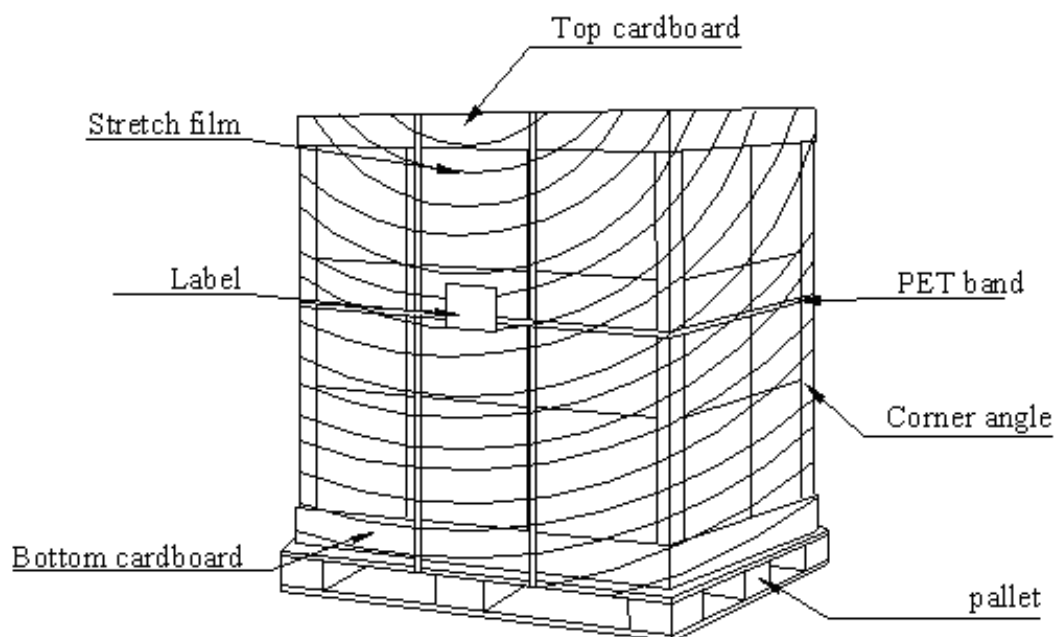

## 10. Appendix: EDID Description

B140XW03 V0 EDID Code

Address	FUNCTION	Value	Value	Value
HEX		HEX	BIN	DEC
00	Header	00	0000000	0
01		FF	11111111	255
02		FF	11111111	255
03		FF	11111111	255
04		FF	11111111	255
05		FF	11111111	255
06		FF	11111111	255
07		00	0000000	0
08	EISA Manuf. Code LSB	06	0000011	6
09	Compressed ASCII	AF	1010111	175
0A	Product Code	3C	0011110	60
0B	hex, LSB first	30	0011000	48
0C	32-bit ser #	00	0000000	0
0D		00	0000000	0
0E		00	0000000	0
0F		00	0000000	0
10	Week of manufacture	01	0000000	1
11	Year of manufacture	13	0001001	19
12	EDID Structure Ver.	01	0000000	1
13	EDID revision #	03	0000001	3
14	<b>Video input def.</b> ( <i>digital I/P, non-TMDS, CRGB</i> )	80	1000000	128
15	<b>Max H image size</b> ( <i>rounded to cm</i> )	1F	0001111	31
16	<b>Max V image size</b> ( <i>rounded to cm</i> )	11	0001000	17
17	<b>Display Gamma</b> ( <i>=(gamma*100)-100</i> )	78	0111100	120
18	<b>Feature support</b> ( <i>no DPMS, Active OFF, RGB, tmg Blk</i> )	0A	0000101	10
19	Red/green low bits ( <b>Lower 2:2:2:2 bits</b> )	C8	1100100	200
1A	Blue/white low bits ( <b>Lower 2:2:2:2 bits</b> )	A5	1010010	165
1B	Red x ( <b>Upper 8 bits</b> )	9E	1001111	158
1C	Red y/ highER 8 bits	57	0101011	87
1D	Green x	54	0101010	84
1E	Green y	92	1001001	144
1F	Blue x	26	0010011	38
20	Blue y	99	1001100	152
21	White x	50	0101000	80
22	White y	54	0101010	84
23	Established timing 1	00	0000000	0
24	Established timing 2	00	0000000	0
25	Established timing 3	00	0000000	0
26	Standard timing #1	01	0000000	1
27		01	0000000	1
28	Standard timing #2	01	0000000	1
29		01	0000000	1
2A	Standard timing #3	01	0000000	1

2B		01	0000000	1
2C	Standard timing #4	01	0000000	1
2D		01	0000000	1
2E	Standard timing #5	01	0000000	1
2F		01	0000000	1
30	Standard timing #6	01	0000000	1
31		01	0000000	1
32	Standard timing #7	01	0000000	1
33		01	0000000	1
34	Standard timing #8	01	0000000	1
35		01	0000000	1
36	Pixel Clock/10000 LSB	12	0001001	18
37	Pixel Clock/10000 USB	1E	0001101	27
38	Horz active <b>Lower 8bits</b>	56	0101011	86
39	Horz blanking <b>Lower 8bits</b>	46	0100011	70
3A	HorzAct:HorzBlnk <b>Upper 4:4 bits</b>	50	0101000	80
3B	Vertical Active <b>Lower 8bits</b>	00	0000000	0
3C	Vertical Blanking <b>Lower 8bits</b>	23	0010001	35
3D	Vert Act : Vertical Blanking <b>(upper 4:4 bit)</b>	30	0011000	48
3E	HorzSync. Offset	26	0010011	38
3F	HorzSync.Width	16	0001011	22
40	VertSync.Offset : VertSync.Width	36	0011011	54
41	Horz&Vert Sync Offset/Width <b>Upper 2bits</b>	00	0000000	0
42	Horizontal Image Size <b>Lower 8bits</b>	35	0011010	53
43	Vertical Image Size <b>Lower 8bits</b>	AD	1010110	173
44	Horizontal & Vertical Image Size <b>(upper 4:4 bits)</b>	10	0001000	16
45	Horizontal Border <i>(zero for internal LCD)</i>	00	0000000	0
46	Vertical Border <i>(zero for internal LCD)</i>	00	0000000	0
47	Signal <i>(non-intr, norm, no stero, sep sync, neg pol)</i>	18	0001100	24
48	Detailed timing/monitor	00	0000000	0
49	descriptor #2	00	0000000	0
4A		00	0000000	0
4B		0F	0000111	15
4C		00	0000000	0
4D		00	0000000	0
4E		00	0000000	0
4F		00	0000000	0
50		00	0000000	0
51		00	0000000	0
52		00	0000000	0
53		00	0000000	0
54		00	0000000	0
55		00	0000000	0
56		00	0000000	0
57		00	0000000	0
58		00	0000000	0
59		20	0010000	32
5A	Detailed timing/monitor	00	0000000	0
5B	descriptor #3	00	0000000	0

5C		00	0000000	0
5D		FE	1111111	25
5E		00	0000000	0
5F	Manufacture	41	0100000	65
60	Manufacture	55	0101010	85
61	Manufacture	4F	0100111	79
62		0A	0000101	10
63		20	0010000	32
64		20	0010000	32
65		20	0010000	32
66		20	0010000	32
67		20	0010000	32
68		20	0010000	32
69		20	0010000	32
6A		20	0010000	32
6B		20	0010000	32
6C	Detailed timing/monitor	00	0000000	0
6D	descriptor #4	00	0000000	0
6E		00	0000000	0
6F		FE	1111111	25
70		00	0000000	0
71	Manufacture P/N	42	0100001	66
72	Manufacture P/N	31	0011000	49
73	Manufacture P/N	34	0011010	52
74	Manufacture P/N	30	0011000	48
75	Manufacture P/N	58	0101100	88
76	Manufacture P/N	57	0101011	87
77	Manufacture P/N	30	0011000	48
78	Manufacture P/N	33	0011001	51
79	Manufacture P/N	20	0010000	32
7A	Manufacture P/N	56	0101011	86
7B	Manufacture P/N	30	0011000	48
7C		20	0010000	32
7D		0A	0000101	10
7E	Extension Flag	00	0000000	0
7F	Checksum	5	0000010	5
			SUM	588
			SUM to HEX	170