

# mass integrated

global part distribution • product lifecycle partner  
excess inventory management • value-ad service provider



Data sheet provided by Mass Integrated

[massintegrated.com](http://massintegrated.com) • [displayalliance.com](http://displayalliance.com)

Please call +1.978.465.6190  
Email: [sales@massintegrated.com](mailto:sales@massintegrated.com)



ISO 9001: 2008

Mass Integrated complies with all DMCA takedown notices. Please send a formal DMCA Takedown Notice to Mass Integrated Systems, Inc. • 18 Henry Graf Jr. Road, Unit 1 • Newburyport, MA 01950.





## Contents

<b>1. Handling Precautions</b>	<b>4</b>
<b>2. General Description</b>	<b>5</b>
2.1 General Specification	5
2.2 Optical Characteristics	6
<b>3. Functional Block Diagram</b>	<b>11</b>
<b>4. Absolute Maximum Ratings</b>	<b>12</b>
4.1 Absolute Ratings of TFT LCD Module	12
4.2 Absolute Ratings of Backlight Unit	12
4.3 Absolute Ratings of Environment	12
<b>5. Electrical characteristics</b>	<b>13</b>
5.1 TFT LCD Module	13
5.2 Backlight Unit	15
<b>6. Signal Characteristic</b>	<b>17</b>
6.1 Pixel Format Image	17
6.2 The input data format	18
6.3 Signal Description/Pin Assignment	19
6.4 Interface Timing	22
<b>7. Connector Description</b>	<b>25</b>
7.1 TFT LCD Module	25
7.2 Backlight Unit	25
7.3 Signal for Lamp connector	25
<b>8. Dynamic Test</b>	<b>26</b>
8.1 Vibration Test	26
8.2 Shock Test Spec:	26
<b>9. Reliability</b>	<b>27</b>
<b>10. Mechanical Characteristics</b>	<b>28</b>
10.1 LCM Outline Dimension	28
10.2 Screw Hole Depth and Center Position	30
<b>11. Shipping and Package</b>	<b>31</b>
11.1 Shipping Label Format	31
11.2 Carton package	32
11.3 Shipping package of palletizing sequence	32
<b>12. Appendix: EDID description</b>	<b>33</b>





## 1. Handling Precautions

- 1) Since front polarizer is easily damaged, pay attention not to scratch it.
- 2) Be sure to turn off power supply when inserting or disconnecting from input connector.
- 3) Wipe off water drop immediately. Long contact with water may cause discoloration or spots.
- 4) When the panel surface is soiled, wipe it with absorbent cotton or other soft cloth.
- 5) Since the panel is made of glass, it may break or crack if dropped or bumped on hard surface.
- 6) Since CMOS LSI is used in this module, take care of static electricity and insure human earth when handling.
- 7) Do not open nor modify the Module Assembly.
- 8) Do not press the reflector sheet at the back of the module to any directions.
- 9) In case if a Module has to be put back into the packing container slot after once it was taken out from the container, do not press the center of the CCFL Reflector edge. Instead, press at the far ends of the CCFL Reflector edge softly. Otherwise the TFT Module may be damaged.
- 10) At the insertion or removal of the Signal Interface Connector, be sure not to rotate nor tilt the Interface Connector of the TFT Module.
- 11) After installation of the TFT Module into an enclosure (Notebook PC Bezel, for example), do not twist nor bend the TFT Module even momentary. At designing the enclosure, it should be taken into consideration that no bending/twisting forces are applied to the TFT Module from outside. Otherwise the TFT Module may be damaged.
- 12) Cold cathode fluorescent lamp (CCFL) in LCD contains a small amount of mercury. Please follow local ordinances or regulations for disposal.
- 13) Small amount of materials having no flammability grade is used in the LCD module. The LCD module should be supplied by power complied with requirements of Limited Power Source (IEC60950 or UL1950), or be applied exemption.
- 14) The LCD module is designed so that the CCFL in it is supplied by Limited Current Circuit (IEC60950 or UL1950). Do not connect the CCFL in Hazardous Voltage Circuit.



# Product Specification

AU OPTRONICS CORPORATION

## 2. General Description

B154SW01 V9 is a Color Active Matrix Liquid Crystal Display composed of a TFT LCD panel, a driver circuit, and backlight system. The screen format is intended to support the WSXGA+ (1680(H) x 1050(V)) screen and 262k colors (RGB 6-bits data driver) without backlight inverter. All input signals are LVDS interface compatible.

B154SW01 V9 is designed for a display unit of notebook style personal computer and industrial machine.

### 2.1 General Specification

The following items are characteristics summary on the table at 25 °C condition:

Items	Unit	Specifications			
Screen Diagonal	[mm]	391 (15.4W")			
Active Area	[mm]	331.4 x 207.1			
Pixels H x V		1680 x 3(RGB) x 1050			
Pixel Pitch	[mm]	0.19725 x 0.19725			
Pixel Format		R.G.B. Vertical Stripe			
Display Mode		Normally White			
White Luminance (I <sub>CCFL</sub> =6.0mA) Note: I <sub>CCFL</sub> is lamp current	[cd/m <sup>2</sup> ]	200 typ. (5 points average) 170 min. (5 points average) (Note1)			
Luminance Uniformity		1.25 max. (5 points) 1.66max (13 points) (Note2)			
Contrast Ratio		400 typ			
Response Time	[ms]	8 typ / 16 max			
Nominal Input Voltage VDD	[Volt]	+3.3 typ.			
Power Consumption	[Watt]	TBD max.			
Weight	[Grams]	570 max.			
Physical Size	[mm]		L	W	T
		Max	344.5	222.5	6.5
		Typical	344	222	-
		Min	343.5	221.5	-
Electrical Interface		2 channel LVDS			
Surface Treatment		Antiglare, Hardness 2H,			



# Product Specification

AU OPTRONICS CORPORATION

Support Color		262K colors ( RGB 6-bit )
Temperature Range Operating Storage (Non-Operating)	[°C] [°C]	0 to +50 -20 to +60
RoHS Compliance		RoHS Compliance

## 2.2 Optical Characteristics

The optical characteristics are measured under stable conditions at 25°C (Room Temperature) :

Item	Unit	Conditions	Min.	Typ.	Max.	Note
White Luminance I <sub>CCFL</sub> =6.0mA	[cd/m <sup>2</sup> ]	5 points average	170	200	-	1, 4, 5.
Viewing Angle	[degree]	Horizontal (Right)	-	70	-	8
	[degree]	CR = 10 (Left)	-	70	-	
	[degree]	Vertical (Upper)	-	60	-	
	[degree]	CR = 10 (Lower)	-	60	-	
Luminance Uniformity		5 Points	-	-	1.25	1
Luminance Uniformity		13 Points	-	-	1.66	2
CR: Contrast Ratio			300	400	-	6
Cross talk	%				TBD	7
Response Time	[msec]	Rising	-	-	-	8
	[msec]	Falling	-	-	-	
	[msec]	Rising + Falling	-	8	16	
Chromaticity of color Coordinates (CIE 1931)		Red x	0.547	0.577	0.607	2,8
		Red y	0.308	0.338	0.368	
		Green x	0.280	0.310	0.340	
		Green y	0.533	0.563	0.593	
		Blue x	0.128	0.158	0.188	
		Blue y	0.127	0.157	0.187	
		White x	0.285	0.313	0.341	
	White y	0.309	0.329	0.349		
NTSC	%	CIE 1931	-	45	-	

Note 1: 5 points position (Ref: Active area)

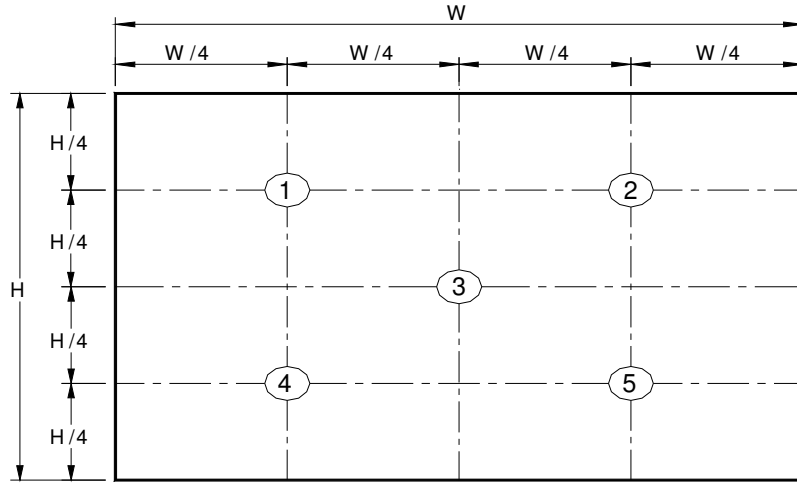

Note 2: 13 points position (Ref: Active area)

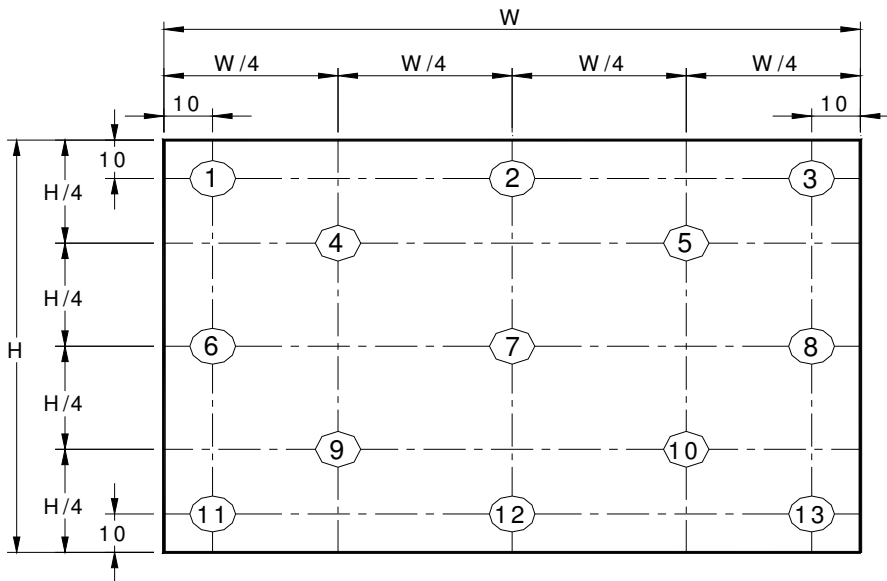

Note 3: The luminance uniformity of 5 or 13 points is defined by dividing the maximum luminance values by the minimum test point luminance

$$\delta_{w5} = \frac{\text{Maximum Brightness of five points}}{\text{Minimum Brightness of five points}}$$

$$\delta_{w13} = \frac{\text{Maximum Brightness of thirteen points}}{\text{Minimum Brightness of thirteen points}}$$

Note 4: Measurement method

The LCD module should be stabilized at given temperature for 30 minutes to avoid abrupt temperature change during measuring. In order to stabilize the luminance, the measurement should be executed after lighting Backlight for 30 minutes in a stable, windless and dark room.

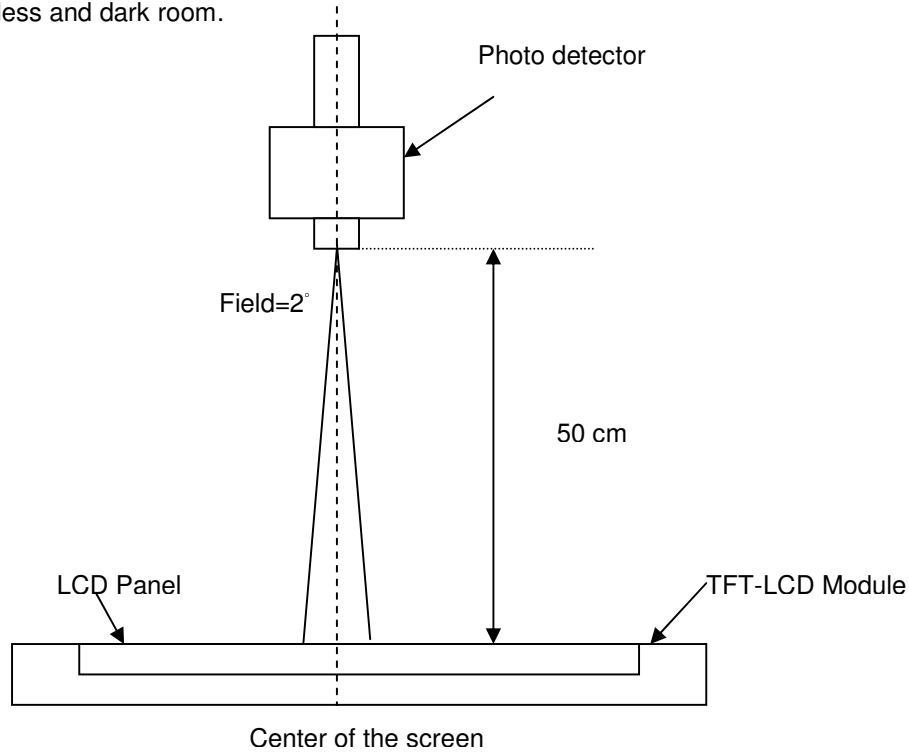

Note 5 : Definition of Average Luminance of White ( $Y_L$ ):

Measure the luminance of gray level 63 at 5 points ,  $Y_L = [L (1)+ L (2)+ L (3)+ L (4)+ L (5)] / 5$

$L (x)$  is corresponding to the luminance of the point X at Figure in Note (1).

Note 6 : Definition of contrast ratio:

Contrast ratio is calculated with the following formula.

$$\text{Contrast ratio (CR)} = \frac{\text{Brightness on the "White" state}}{\text{Brightness on the "Black" state}}$$

Note 7 : Definition of Cross Talk (CT)

$$CT = |Y_B - Y_A| / Y_A \times 100 (\%)$$

Where

$Y_A$  = Luminance of measured location without gray level 0 pattern (cd/m<sup>2</sup>)

$Y_B$  = Luminance of measured location with gray level 0 pattern (cd/m<sup>2</sup>)

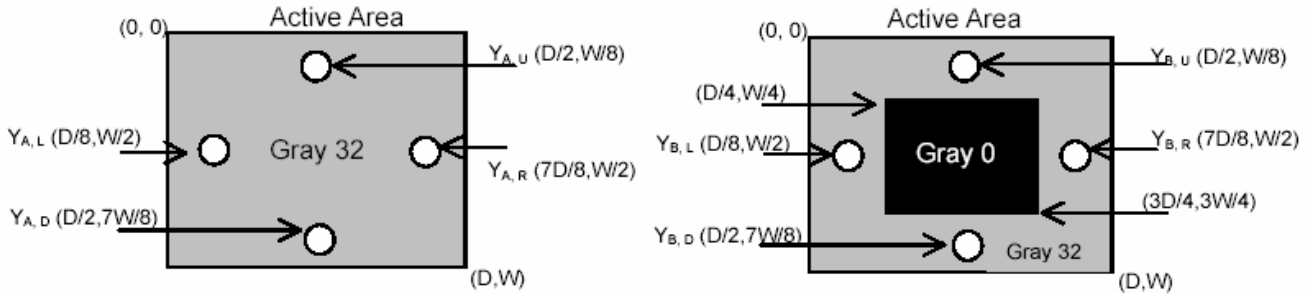

Note 8: Definition of response time:

The output signals of BM-7 or equivalent are measured when the input signals are changed from "Black" to "White" (falling time) and from "White" to "Black" (rising time), respectively. The response time interval between the 10% and 90% of amplitudes. Refer to figure as below.

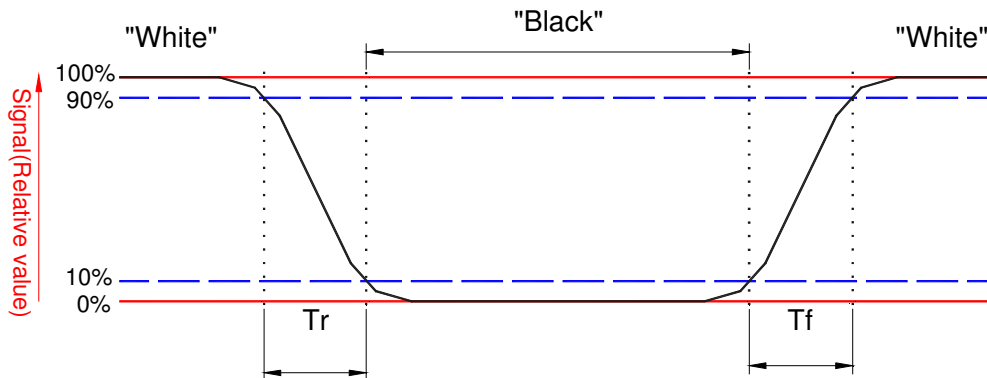

Note 8. Definition of viewing angle

Viewing angle is the measurement of contrast ratio  $\geq 10$ , at the screen center, over a  $180^\circ$  horizontal and  $180^\circ$  vertical range (off-normal viewing angles). The  $180^\circ$  viewing angle range is broken down as follows;  $90^\circ$  ( $\theta$ ) horizontal left and right and  $90^\circ$  ( $\Phi$ ) vertical, high (up) and low (down). The measurement direction is typically perpendicular to the display surface with the screen rotated about its center to develop the desired measurement viewing angle.

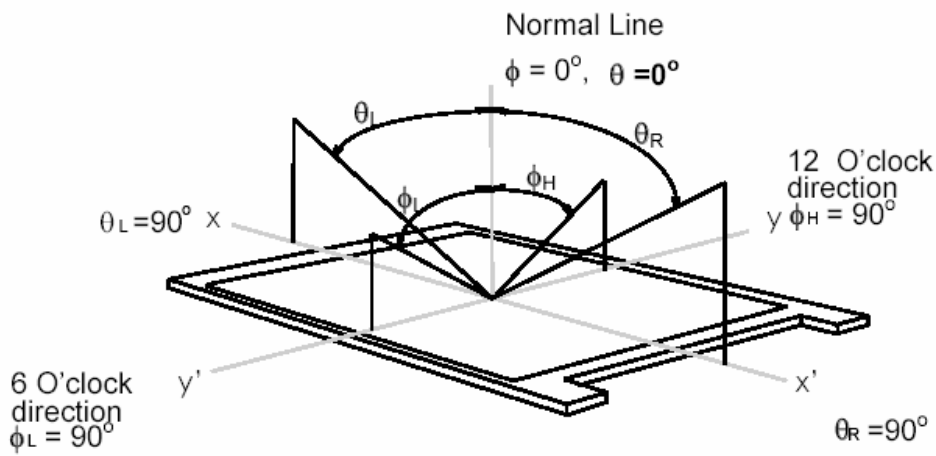

## 3. Functional Block Diagram

The following diagram shows the functional block of the 15.4 inches wide Color TFT/LCD Module:

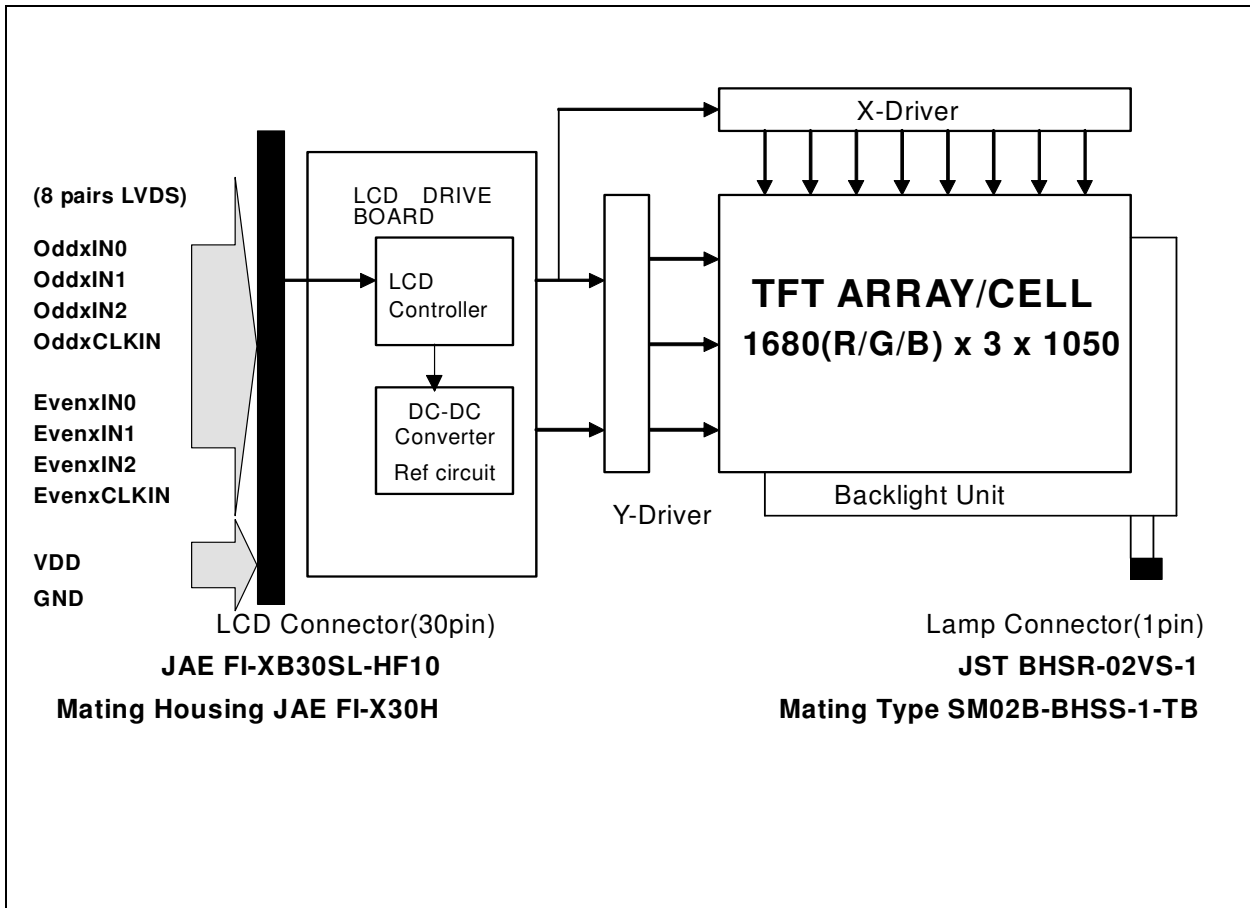

## 4. Absolute Maximum Ratings

An absolute maximum rating of the module is as following:

### 4.1 Absolute Ratings of TFT LCD Module

Item	Symbol	Min	Max	Unit	Conditions
Logic/LCD Drive Voltage	Vin	-0.3	+4.0	[Volt]	Note 1,2

### 4.2 Absolute Ratings of Backlight Unit

Item	Symbol	Min	Max	Unit	Conditions
CCFL Current	ICCFL	-	6.5	[mA] rms	Note 1,2

### 4.3 Absolute Ratings of Environment

Item	Symbol	Min	Max	Unit	Conditions
Operating Temperature	TOP	0	+50	[°C]	Note 3
Operation Humidity	HOP	5	95	[%RH]	Note 3
Storage Temperature	TST	-20	+60	[°C]	Note 3
Storage Humidity	HST	5	95	[%RH]	Note 3

Note 1: At Ta (25°C )

Note 2: Permanent damage to the device may occur if exceed maximum values

**Note 3: For quality performance, please refer to AUO IIS (Incoming Inspection Standard).**

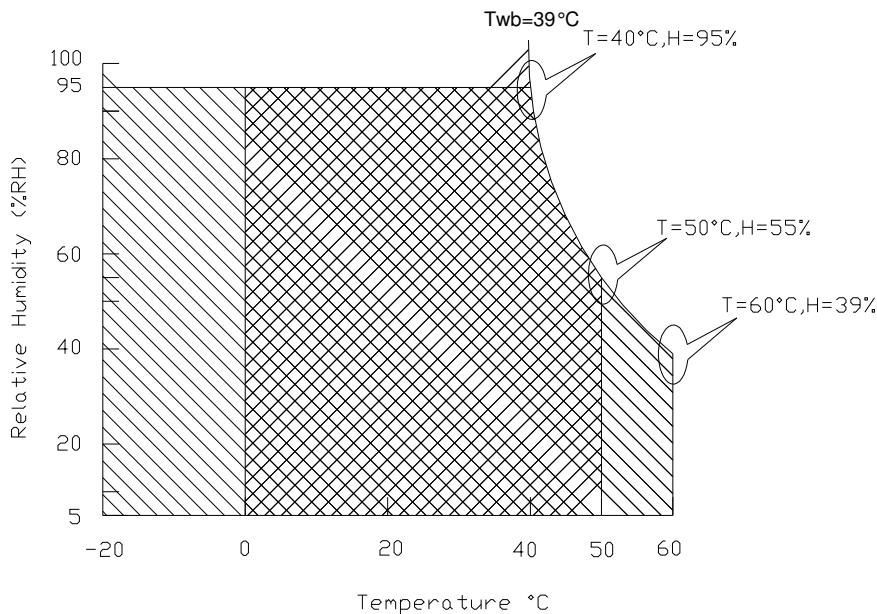

Operating Range 

Storage Range

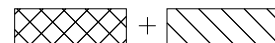

## 5. Electrical characteristics

### 5.1 TFT LCD Module

#### 5.1.1 Power Specification

Input power specifications are as follows;

Symble	Parameter	Min	Typ	Max	Units	Note
VDD	Logic/LCD Drive Voltage	3.0	3.3	3.6	[Volt]	
PDD	VDD Power	-	-	TBD	[Watt]	Note 1/2
IDD	IDD Current	TBD	TBD	TBD	[mA]	Note 1/2
IRush	Inrush Current	-	-	2000	[mA]	Note 3
VDDrp	Allowable Logic/LCD Drive Ripple Voltage	-	-	100	[mV] p-p	

Note 1 : Maximum Measurement Condition : Black Pattern (Windows XP pattern VDD Power Typ.: TBDW)

Note 2 : Typical Measurement Condition: Mosaic Pattern

Note 3 : Measure Condition

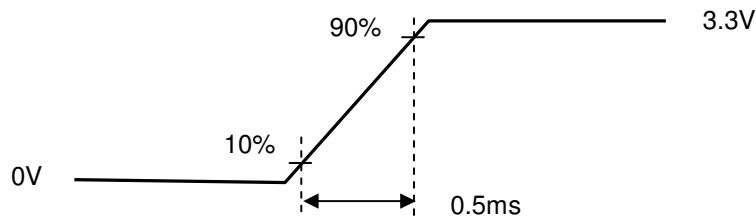
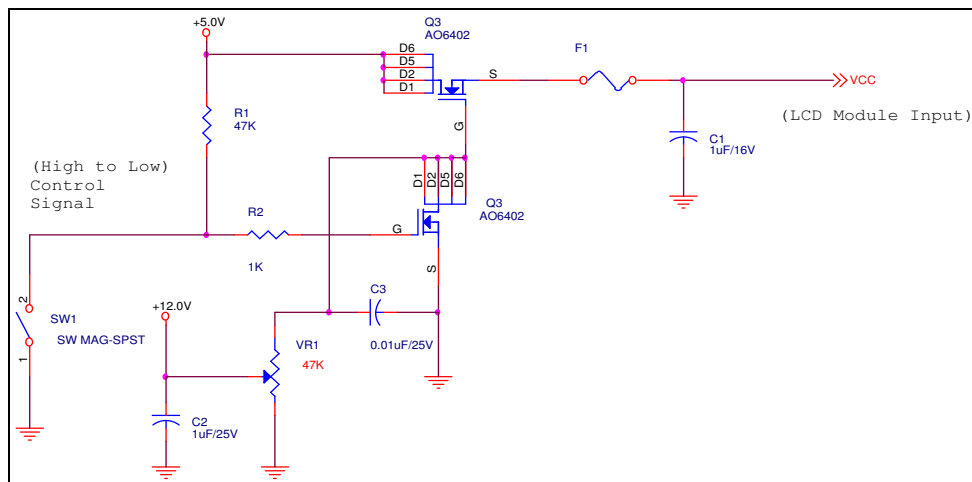

Vin rising time

## 5.1.2 Signal Electrical Characteristics

Input signals shall be low or High-impedance state when VDD is off.

It is recommended to refer the specifications of THC63LVDF84A (Thine Electronics Inc.) in detail.

Signal electrical characteristics are as follows;

Parameter	Condition	Min	Max	Unit
Vth	Differential Input High Threshold (Vcm=+1.2V)	-	100	[mV]
Vtl	Differential Input Low Threshold (Vcm=+1.2V)	-100	-	[mV]
Vcm	Differential Input Common Mode Voltage	1.125	1.375	[V]

Note: LVDS Signal Waveform

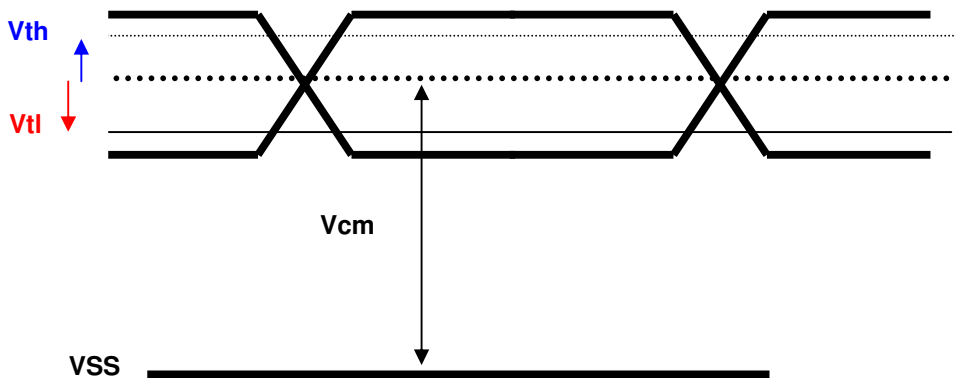



# Product Specification

AU OPTRONICS CORPORATION

## 5.2 Backlight Unit

CCFL Parameter guideline for CCFL Inverter selection (Ref. Remark 1)

Parameter	Min	Typ	Max	Units	Condition
CCFL current(I <sub>CCFL</sub> )	2.0	6.0	6.5	[mA] rms	(Ta=25°C) Note 1
CCFL Frequency(F <sub>CCFL</sub> )	50	-	70	[KHz]	(Ta=25°C) Note 2,3
CCFL startup Voltage(V <sub>s</sub> )			1400	[Volt] rms	(Ta= 0°C) Note 4
CCFL startup Voltage(V <sub>s</sub> )			1400	[Volt] rms	(Ta= 25°C) Note 4
CCFL Voltage (Reference) (V <sub>CCFL</sub> )	653	730	803	[Volt] rms	(Ta=25°C) Note 5
CCFL Power consumption (P <sub>CCFL</sub> )	-	4.38	4.82	[Watt]	(Ta=25°C) Note 5
CCFL Life-Time	12,000	-	-	Hour	(Ta=25°C) Note 7

To optimun TFT LCD performance, the LAMP Frequesncy define as:50~60 kHz

**Remark 1:** Typ are AUO recommended Design Points.

- 1-1 All of characteristics listed are measured under the condition using the Lenovo Test inverter.
- 1-2 In case of using an inverter other than listed, it is recommended to check the inverter carefully.  
Sometimes, interfering noise stripes appear on the screen, and substandard luminance or flicker at low power may happen.
- 1-3 In designing an inverter, it is suggested to check safety circuit very carefully. Impedance of CCFL, for instance, becomes more than 1 [M ohm] when CCFL is damaged.
- 1-4 Generally, CCFL has some amount of delay time after applying starting voltage. It is recommended to keep on applying starting voltage for **1 [Sec]** until discharge.
- 1-5 CCFL discharge frequency must be carefully chosen so as not to produce interfering noise stripes on the screen.
- 1-6 Reducing CCFL current increases CCFL discharge voltage and generally increases CCFL discharge frequency. So all the parameters of an inverter should be carefully designed so as not to produce too much leakage current from high-voltage output of the inverter.

**Note 1:** It should be employed the inverter which has “Duty Dimming”, if ICCFL is less than 4mA.

**Note 2:** CCFL discharge frequency should be carefully determined to avoid interference between inverter and TFT LCD.

**Note 3:** The frequency range will not affect to lamp life and reliability characteristics.

**Note 4:** The output voltage of inverter should be able to give out a power after ballast capacitor , the generating capacity have to be larger than a lamp startup voltage, otherwise backlight may has blinking for a moment after turns on or can not be turned on. The value goes with Lenovo system inverter basis.

**Note 5:** Calculator value for reference ( $I_{CCFL} \times V_{CCFL} = P_{CCFL}$ )

**Note 6:** Requirements for a system inverter design, which is intended to have a better display performance, a better power efficiency and a more reliable lamp, are following.

It shall help increase the lamp lifetime and reduce leakage current.

a. The asymmetry rate of the inverter waveform should be less than 10%.

b. The distortion rate of the waveform should be within  $\sqrt{2} \pm 10\%$ .

\* Inverter output waveform had better be more similar to ideal sine wave.

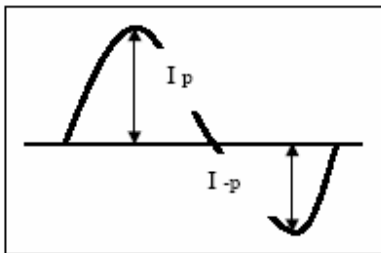

\* Asymmetry rate:  

$$\frac{|I_p - I_{-p}|}{I_{rms}} * 100\%$$
 \* Distortion rate  

$$I_p \text{ (or } I_{-p}) / I_{rms}$$

**Note 7:** It is an edge-type BLU with single CCFL, the life-time define as the brightness decay to 50% of original value and under normal operation.

## 6. Signal Characteristic

### 6.1 Pixel Format Image

Following figure shows the relationship of the input signals and LCD pixel format.

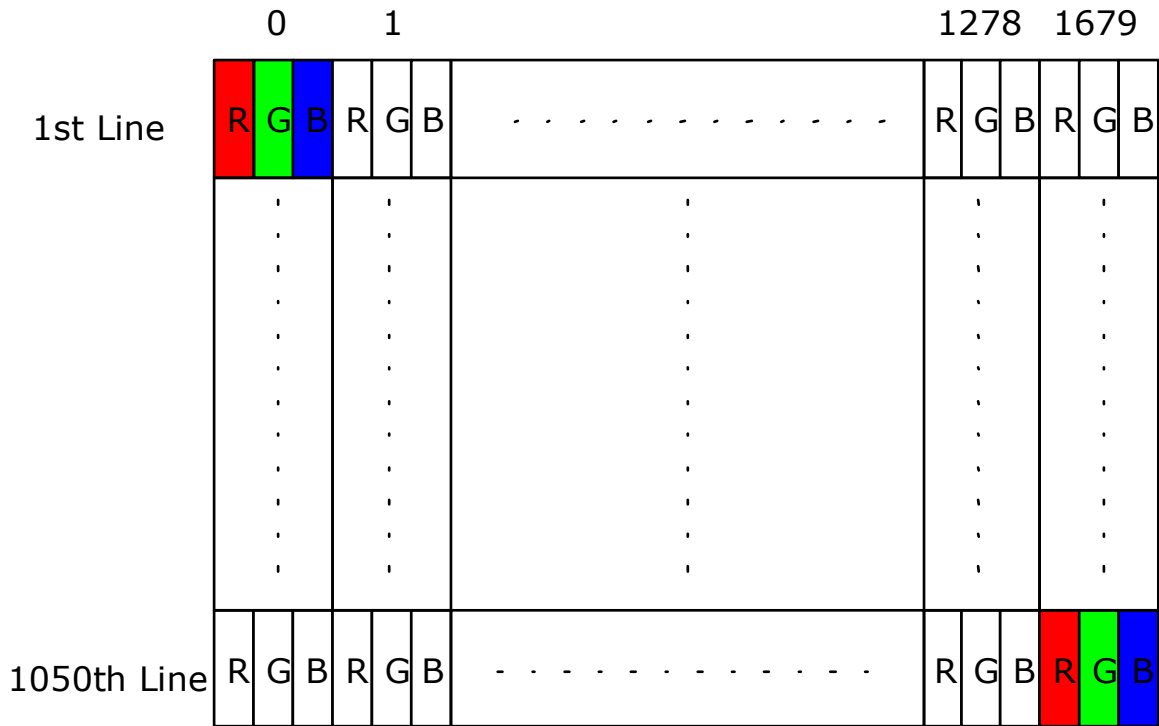

## 6.2 The input data format

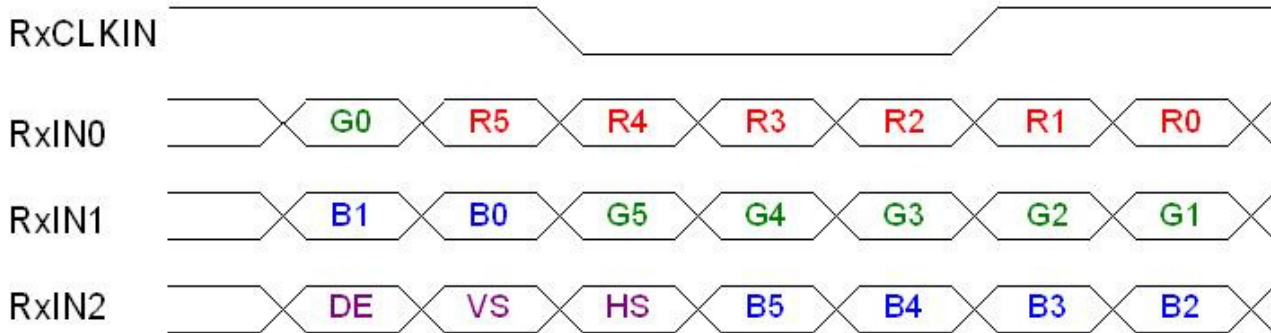

Signal Name	Description	
R5 R4 R3 R2 R1 R0	Red Data 5 (MSB) Red Data 4 Red Data 3 Red Data 2 Red Data 1 Red Data 0 (LSB)	Red-pixel Data Each red pixel's brightness data consists of these 6 bits pixel data.
G5 G4 G3 G2 G1 G0	Green Data 5 (MSB) Green Data 4 Green Data 3 Green Data 2 Green Data 1 Green Data 0 (LSB)	Green-pixel Data Each green pixel's brightness data consists of these 6 bits pixel data.
B5 B4 B3 B2 B1 B0	Blue Data 5 (MSB) Blue Data 4 Blue Data 3 Blue Data 2 Blue Data 1 Blue Data 0 (LSB)	Blue-pixel Data Each blue pixel's brightness data consists of these 6 bits pixel data.
RxCLKIN	Data Clock	The typical frequency is 59.5 MHz. The signal is used to strobe the pixel data and DE signals. All pixel data shall be valid at the falling edge when the DE signal is low.
DE	Display Timing	This signal is strobed at the falling edge of RxCLKIN. When the signal is high, the pixel data shall be valid to be displayed.
VS	Vertical Sync	The signal is synchronized to RxCLKIN.
HS	Horizontal Sync	The signal is synchronized to RxCLKIN.

Note: Output signals from any system shall be low or High-impedance state when VDD is off.



## 6.3 Signal Description/Pin Assignment

LVDS is a differential signal technology for LCD interface and high speed data transfer device.

PIN#	Signal Name	Description
1	GND	Power Ground
2	VDD	+ 3.3V Power Supply
3	VDD	+ 3.3V Power Supply
4	VEDID	+ 3.3V EDID Power
5	AGING	Aging Mode Power Supply
6	CLKEDID	EDID Clock Input
7	DATAEDID	EDID Data Input
8	Odd_Rin0-	-LVDS Differential Data Input
9	Odd_Rin0+	+LVDS Differential Data Input
10	GND	Power Ground
11	Odd_Rin1-	-LVDS Differential Data Input
12	Odd_Rin1+	+LVDS Differential Data Input
13	GND	Power Ground
14	Odd_Rin2-	-LVDS Differential Data Input
15	Odd_Rin2+	+LVDS Differential Data Input
16	GND	Power Ground
17	Odd_ClkIN-	-LVDS Differential Clock Input
18	Odd_ClkIN+	+LVDS Differential Clock Input
19	GND	Power Ground
20	Even_Rin0-	-LVDS Differential Data Input
21	Even_Rin0+	+LVDS Differential Data Input
22	GND	Power Ground
23	Even_Rin1-	-LVDS Differential Data Input
24	Even_Rin1+	+LVDS Differential Data Input
25	GND	Power Ground
26	Even_Rin2-	-LVDS Differential Data Input
27	Even_Rin2+	+LVDS Differential Data Input
28	GND	Power Ground
29	Even_ClkIN-	-LVDS Differential Clock Input
30	Even_ClkIN+	+LVDS Differential Clock Input

Note1: Start from right side

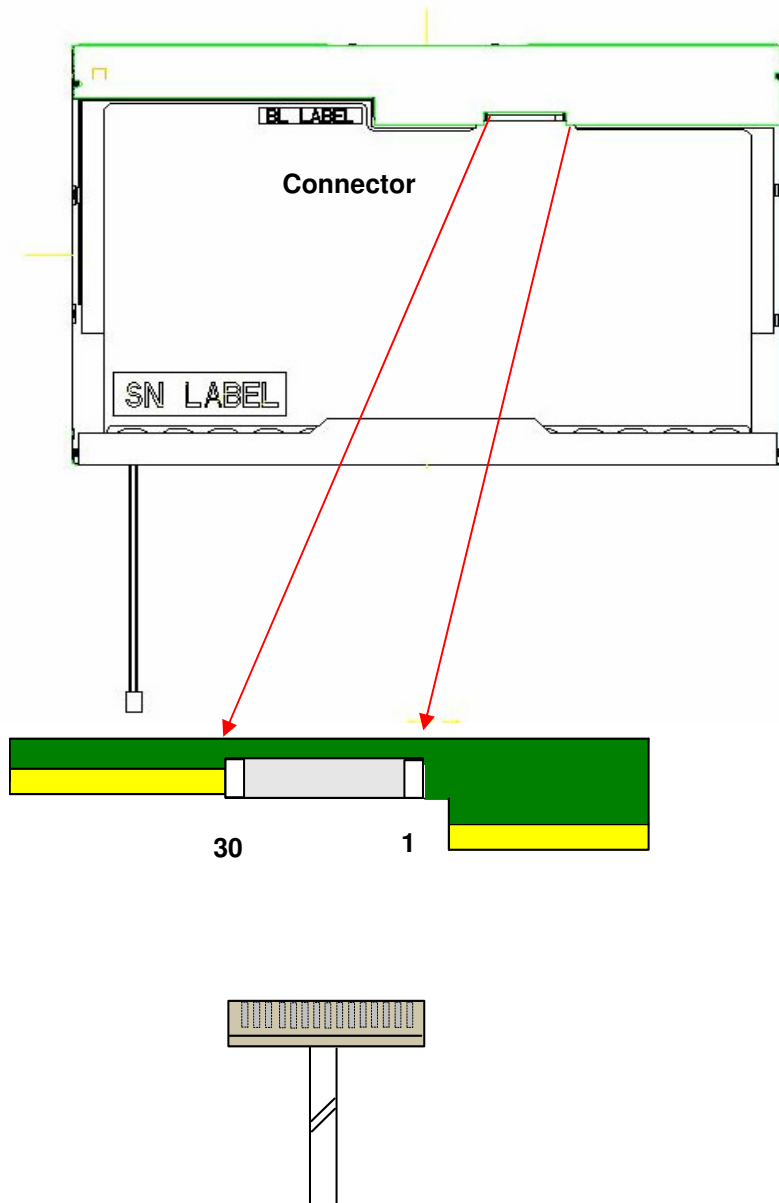

Note2: Input signals shall be low or High-impedance state when VDD is off.

internal circuit of LVDS inputs are as following.

The module uses a 100ohm resistor between positive and negative data lines of each receiver input

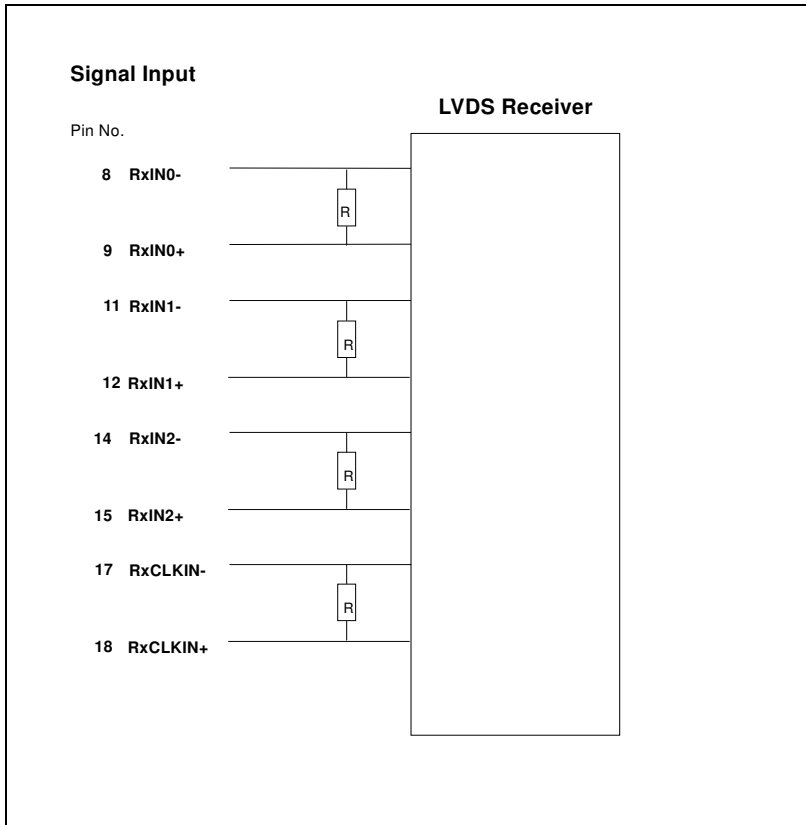

## 6.4 Interface Timing

### 6.4.1 Timing Characteristics

Basically, interface timings should match the 1680x1050 /59.5Hz manufacturing guide line timing.

Parameter	Symbol	Min.	Typ.	Max.	Unit	
Frame Rate	-	50	60	-	Hz	
Clock frequency	$1/ T_{\text{Clock}}$	40	59.5	80	MHz	
Vertical Section	Period	$T_V$	-	1080	-	$T_{\text{Line}}$
	Active	$T_{VD}$	400	1050	1200	
	Blanking	$T_{VB}$	-	30	-	
Horizontal Section	Period	$T_H$	-	1840	-	$T_{\text{Clock}}$
	Active	$T_{HD}$	1680	1680	1680	
	Blanking	$T_{HB}$	-	160	-	

Note : DE mode only

## 6.4.2 Timing diagram

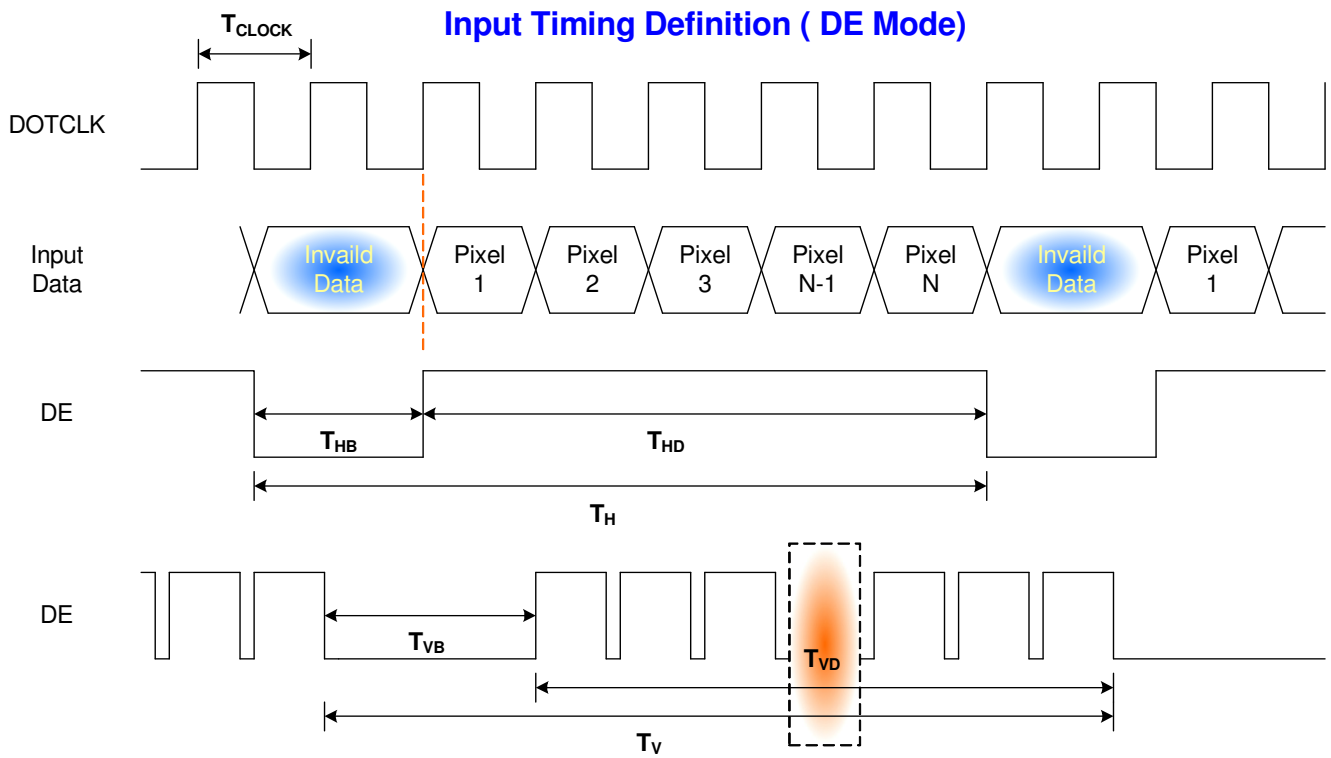

## 6.5 Power ON/OFF Sequence

VDD power and lamp on/off sequence is as follows. Interface signals are also shown in the chart. Signals from any system shall be Hi-Z state or low level when VDD is off.

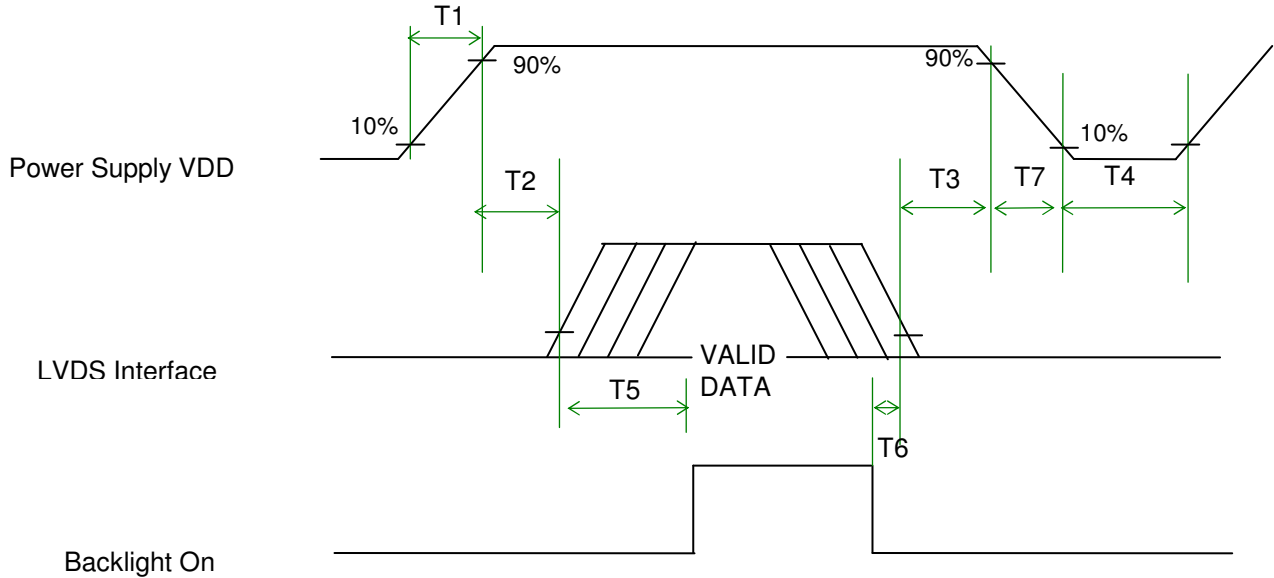

### Power Sequence Timing

Parameter	Value			Units
	Min.	Typ.	Max.	
T1	0.3	-	10	(ms)
T2	0	-	50	(ms)
T3	0	-	-	(ms)
T4	150	-	-	(ms)
T5	200	-	-	(ms)
T6	0	-	-	(ms)
T7	0	-	10	(ms)

**Note 1:** Min. value of T1 parameter is designed to be 0.5ms if the value is set to be 0.3ms, the max. value of inrush current will increase at the same time.

**Note 2:** Max. value of T3 parameter is designed to be 50ms, if the value didn't defined, display may not turn on because Tcon IC may be damaged.

**Note 3:** Min. value of T4 parameter is designed to be 400ms, if the value is set to be 150ms, display garber may occur.

**Note 4:** Min. value of T6 parameter is designed to be 200ms, if the value is set to be 0ms, display garber may occur.

## 7. Connector Description

Physical interface is described as for the connector on module.

These connectors are capable of accommodating the following signals and will be following components.

### 7.1 TFT LCD Module

Connector Name / Designation	For Signal Connector
Manufacturer	JAE
Type / Part Number	FI-XB30SL-HF10
Mating Housing/Part Number	FI-X30H

### 7.2 Backlight Unit

Physical interface is described as for the connector on module.

These connectors are capable of accommodating the following signals and will be following components.

Connector Name / Designation	For Lamp Connector
Manufacturer	JST
Type / Part Number	BHSR-02VS-1
Mating Type / Part Number	SM02B-BHSS-1-TB

### 7.3 Signal for Lamp connector

Pin #	Cable color	Signal Name
1	Pink	Lamp High Voltage
2	White	Lamp Low Voltage

## 8. Dynamic Test

### 8.1 Vibration Test

**Test condition:**

- Acceleration: 2.16G
- Frequency: 10 - 500Hz Random
- Sweep: 30 Minutes each Axis (X, Y, Z)

### 8.2 Shock Test Spec:

**Test condition:**

- Acceleration: 240 G , Half sine wave
- Active time: 2 ms
- Pulse: +/-X,+/-Y,+/-Z , one time for each side

**Remark:**

1. Ambient condition is  $25 \pm 5^{\circ}\text{C}$  , Relative humidity : 40% ~ 70%
2. Non-packaged and Non-operation

## 9. Reliability

Items	Required Condition	Note
Temperature Humidity Bias	Ta= 40°C, 95%RH, 300h	
High Temperature Operation	Ta= 50°C, Dry, 300h	
Low Temperature Operation	Ta= 0°C, 300h	
High Temperature Storage	Ta= 60°C, Room RH, 300h	
Low Temperature Storage	Ta= -20°C, Room RH, 300h	
Thermal Shock Test	Ta=-25°C to 65°C, Duration at 30 min, 100 cycles	
ESD	Contact : ±8 KV Air : ±15 KV	Note 1

**Note1:** According to EN 61000-4-2 , ESD class B: Some performance degradation allowed. No data lost  
 . Self-recoverable. No hardware failures.

**Remark:** MTBF (Excluding the CCFL): 30,000 hours with a confidence level 90%





# Product Specification

AU OPTRONICS CORPORATION

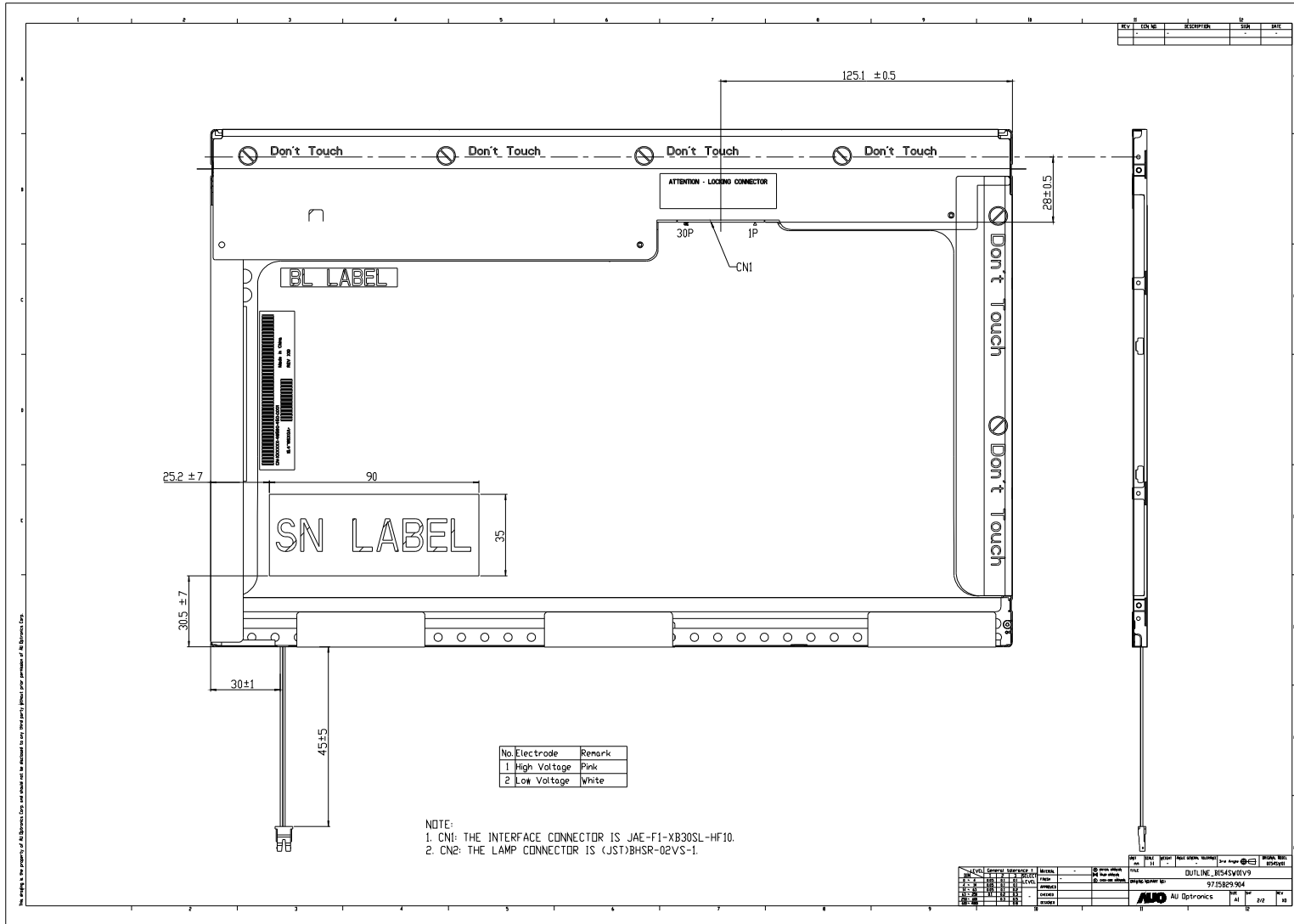

## 10.2 Screw Hole Depth and Center Position

Screw hole minimum depth, from side surface = 2.5 mm (Ref. drawing)

Screw hole center location, from front surface =  $3.7 \pm 0.2$ mm (Ref. drawing)

Screw Torque: Maximum 2.0 kgf-cm

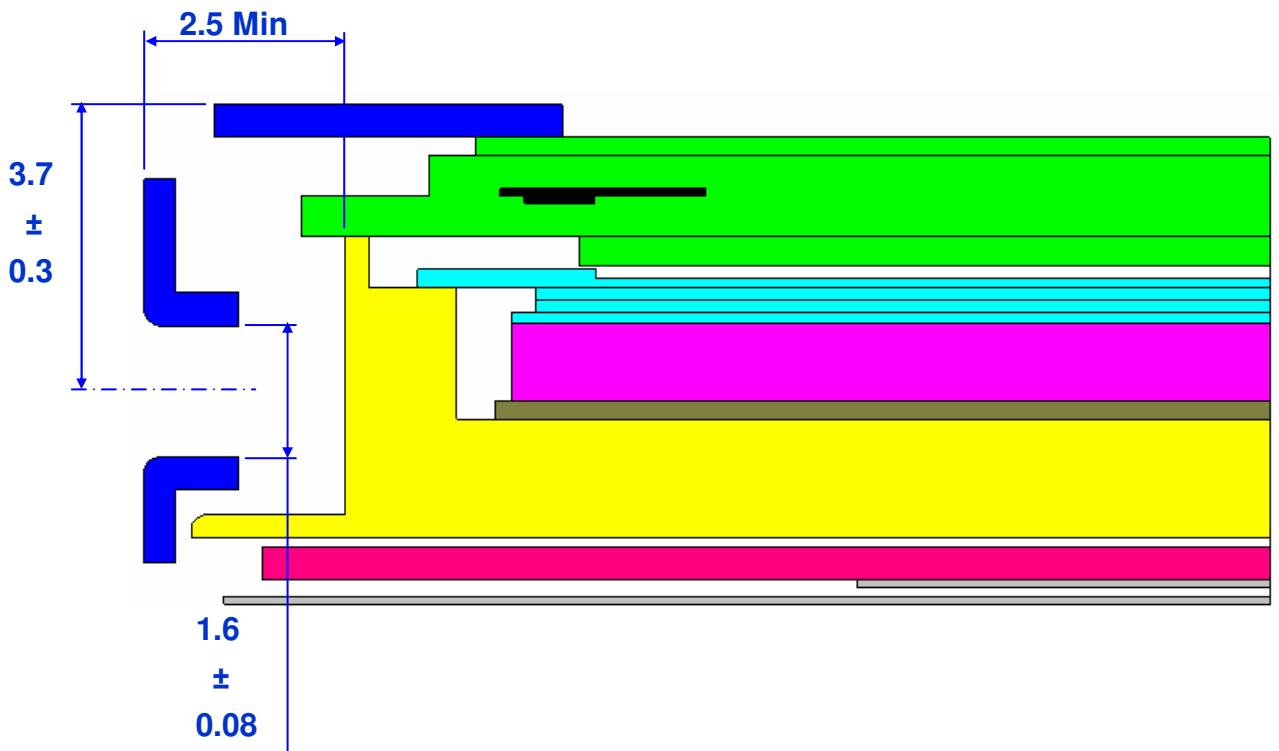

## 11. Shipping and Package

### 11.1 Shipping Label Format



### 11.2 Carton package

The outside dimension of carton is 454 (L)mm x 388 (W)mm x 352 (H)mm

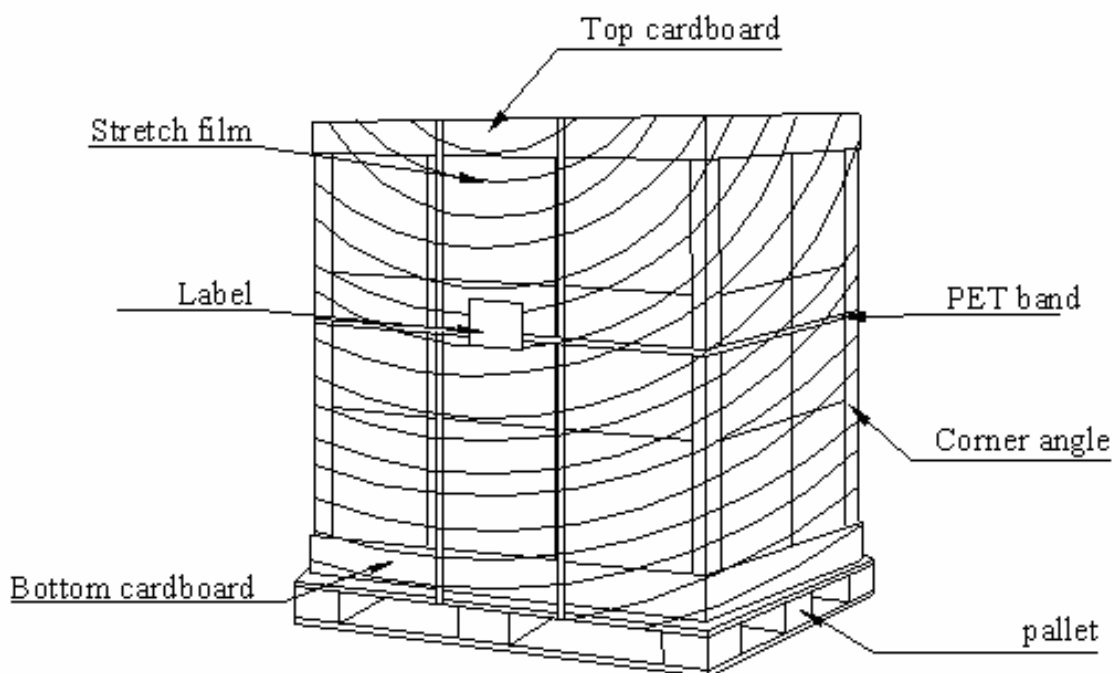
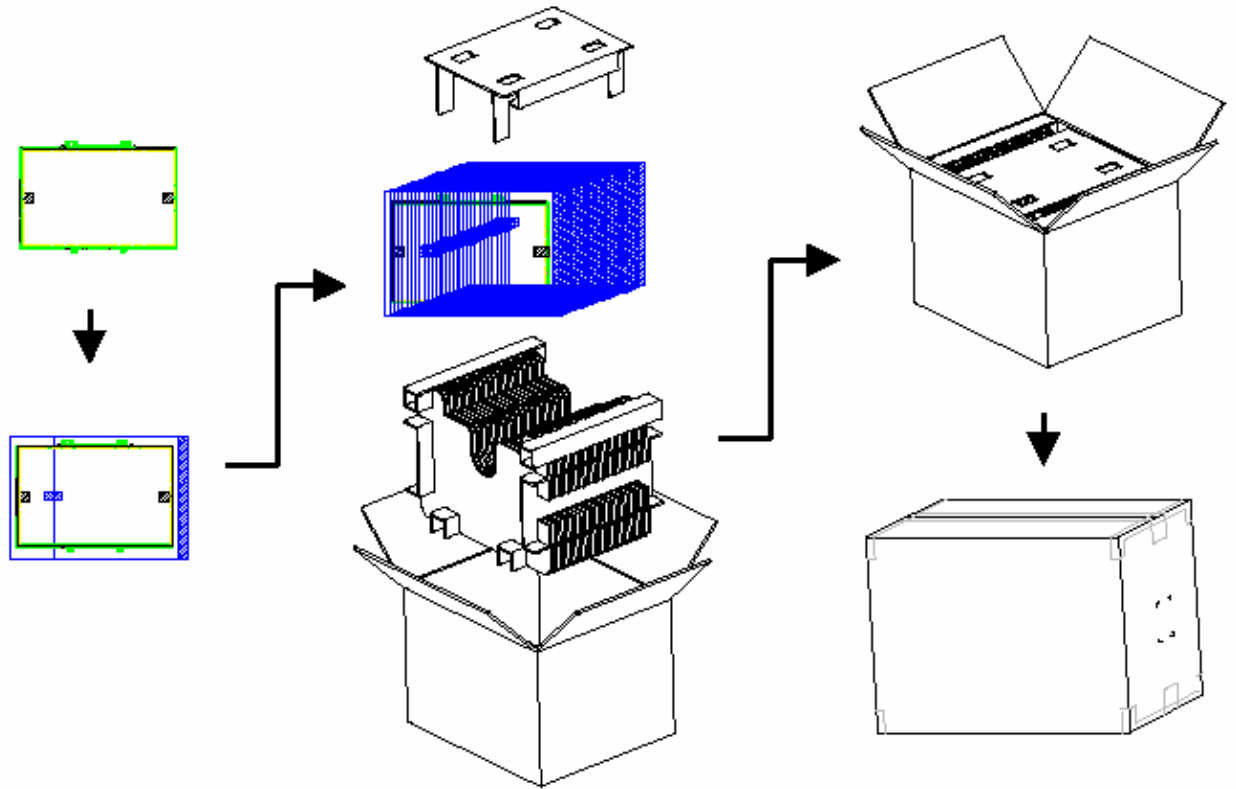



# Product Specification

AU OPTRONICS CORPORATION

## 12. Appendix: EDID description

Address	FUNCTION	Value	Value	Value	Note
HEX		HEX	BIN	DEC	
00	Header	00	00000000	0	
01	Header	FF	11111111	255	
02	Header	FF	11111111	255	
03	Header	FF	11111111	255	
04	Header	FF	11111111	255	
05	Header	FF	11111111	255	
06	Header	FF	11111111	255	
07	Header	00	00000000	0	
08	ID system Manufacturer Name	30	00110000	48	LEN
09	Compressed ASCII	AE	10101110	174	
0A	ID Product Code (LSB)	53	01010011	83	4053
0B	ID Product Code (MSB)	40	01000000	64	
0C	LCD Module Serial No.	00	00000000	0	
0D	LCD Module Serial No.	00	00000000	0	
0E	LCD Module Serial No.	00	00000000	0	
0F	LCD Module Serial No.	00	00000000	0	
10	Week of Manufacture	01	00000001	1	
11	Year of Manufacture	11	00010001	17	2007
12	EDID Structure version	01	00000001	1	
13	EDID Revision	03	00000011	3	
14	Video Input Definition	80	10000000	128	
15	Max H image size(cm)	21	00100001	33	330mm
16	Max V image size(cm)	15	00010101	21	210mm
17	Display gamma	78	01111000	120	2.2
18	Feature support(DPMS)	EA	11101010	234	
19	Red/Green low Bits	87	10000111	135	
1A	Blue/White Low Bits	F5	11110101	245	
1B	Red X	94	10010100	148	
1C	Red Y	57	01010111	87	
1D	Green X	4F	01001111	79	
1E	Green Y	8C	10001100	140	
1F	Blue X	27	00100111	39	
20	Blue Y	27	00100111	39	
21	White X	50	01010000	80	0.313



# Product Specification

AU OPTRONICS CORPORATION

22	White Y	54	01010100	84	0.329
23	Established Timing I	00	00000000	0	
24	Established Timing II	00	00000000	0	
25	Manufacturer's Timings	00	00000000	0	
26	Standard Timing Identification 1	01	00000001	1	
27	Standard Timing Identification 1	01	00000001	1	
28	Standard Timing Identification 2	01	00000001	1	
29	Standard Timing Identification 2	01	00000001	1	
2A	Standard Timing Identification 3	01	00000001	1	
2B	Standard Timing Identification 3	01	00000001	1	
2C	Standard Timing Identification 4	01	00000001	1	
2D	Standard Timing Identification 4	01	00000001	1	
2E	Standard Timing Identification 5	01	00000001	1	
2F	Standard Timing Identification 5	01	00000001	1	
30	Standard Timing Identification 6	01	00000001	1	
31	Standard Timing Identification 6	01	00000001	1	
32	Standard Timing Identification 7	01	00000001	1	
33	Standard Timing Identification 7 was not used	01	00000001	1	
34	Standard Timing Identification 8 was not used	01	00000001	1	
35	Standard Timing Identification 8 was not used	01	00000001	1	
36	Pixel Clock/10,000 (LSB)	A8	10101000	168	122MHz (60Hz)
37	Pixel Clock/10,000 (MSB) /	2F	00101111	47	
38	Horizontal Active	90	10010000	144	1680 pixels
39	Horizontal Blanking	E0	11100000	224	224 pixels
3A	Horizontal Active : Horizontal Blanking	60	01100000	96	
3B	Vertical Active	1A	00011010	26	1050 lines
3C	Vertical Blanking	10	00010000	16	16 lines
3D	Vertical Active : Vertical Blanking	40	01000000	64	
3E	Horizontal Sync. Offset	20	00100000	32	32 pixels
3F	Horizontal Sync Pulse Width	40	01000000	64	64 pixels
40	Vertical Sync Offset : Sync Width	13	00010011	19	1 / 3 lines
41	Horizontal Vertical Sync Offset/Width upper 2bits	00	00000000	0	
42	Horizontal Image Size	4B	01001011	75	331mm
43	Vertical Image Size	CF	11001111	207	207mm
44	Horizontal & Vertical Image Size (upper 4bit)	10	00010000	16	
45	Horizontal Border = 0	00	00000000	0	
46	Vertical Border = 0	00	00000000	0	
47	Non-interlaced,Normal display,no stereo,Digital separate sync,H/V pol negatives	19	00011001	25	



# Product Specification

AU OPTRONICS CORPORATION

48	Pixel Clock/10,000 (LSB)                      50Hz	B7	10110111	183	101.67MHz (50Hz)
49	Pixel Clock/10,000 (MSB) /                      50Hz	27	00100111	39	
4A	Horizontal Active	90	10010000	144	1680 pixels
4B	Horizontal Blanking	E0	11100000	224	224 pixels
4C	Horizontal Active : Horizontal Blanking	60	01100000	96	
4D	Vertical Active	1A	00011010	26	1050 lines
4E	Vertical Blanking	10	00010000	16	16 lines
4F	Vertical Active : Vertical Blanking	40	01000000	64	
50	Horizontal Sync. Offset	20	00100000	32	32 pixels
51	Horizontal Sync Pulse Width	40	01000000	64	64 pixels
52	Vertical Sync Offset : Sync Width	13	00010011	19	1 / 3 lines
53	Horizontal Vertical Sync Offset/Width upper 2bits	00	00000000	0	
54	Horizontal Image Size	4B	01001011	75	331mm
55	Vertical Image Size	CF	11001111	207	207mm
56	Horizontal & Vertical Image Size (upper 4bit)	10	00010000	16	
57	Horizontal Border = 0	00	00000000	0	
58	Vertical Border = 0	00	00000000	0	
59	Non-interlaced,Normal display,no stereo,Digital separate sync,H/V pol negatives	19	00011001	25	
5A	Detailed Timing Descriptor #3	00	00000000	0	
5B		00	00000000	0	
5C		00	00000000	0	
5D		0F	00001111	15	
5E		00	00000000	0	
5F	(Horizontal active pixel /8)-31	B3	10110011	179	1680/8-31
60	Image Aspect Ratio(16:10)	0A	00001010	10	
61	Low Refresh Rate #1(50Hz)	32	00110010	50	50Hz
62	(Horizontal active pixel /8)-31	B3	10110011	179	1680/8-31
63	Image Aspect Ratio(16:10)	0A	00001010	10	
64	Low Refresh Rate #2(40Hz)	28	00101000	40	40Hz
65	Brightness(1/10nit)	14	00010100	20	200nit
66	Feature flag(TN mode)	01	00000001	1	
67	Reserved 00h	00	00000000	0	
68	EISA manufacturer code(3 Character ID)	06	00000110	6	AUO
69	Compressed ASCII	AF	10101111	175	
6A	Panel Supplier Reserved - Product code	74	01110100	116	
6B	(Hex, LSB first)	24	00100100	36	
6C	Detailed Timing Descriptor #4	00	00000000	0	
6D		00	00000000	0	



# Product Specification

AU OPTRONICS CORPORATION

<b>6E</b>		00	00000000	0	
<b>6F</b>		FE	11111110	254	
<b>70</b>		00	00000000	0	
<b>71</b>	(Supplier S/N)	42	01000010	66	[B]
<b>72</b>	(Supplier S/N)	31	00110001	49	[1]
<b>73</b>	(Supplier S/N)	35	00110101	53	[5]
<b>74</b>	(Supplier S/N)	34	00110100	52	[4]
<b>75</b>	(Supplier S/N)	53	01010011	83	[S]
<b>76</b>	(Supplier S/N)	57	01010111	87	[W]
<b>77</b>	(Supplier S/N)	30	00110000	48	[0]
<b>78</b>	(Supplier S/N)	31	00110001	49	[1]
<b>79</b>	(Supplier S/N)	20	00100000	32	[ ]
<b>7A</b>	(Supplier S/N)	56	01010110	86	[v]
<b>7B</b>	(Supplier S/N)	39	00111001	57	[9]
<b>7C</b>	(Supplier S/N)	20	00100000	32	[ ]
<b>7D</b>	(Supplier S/N)	0A	00001010	10	[^]
<b>7E</b>	Extension flag = 00	00	00000000	0	
<b>7F</b>	Checksum	8B	10001011	139	