

mass integrated

global part distribution • product lifecycle partner
excess inventory management • value-ad service provider



Data sheet provided by Mass Integrated

massintegrated.com • displayalliance.com

Please call +1.978.465.6190
Email: sales@massintegrated.com



ISO 9001: 2008

Mass Integrated complies with all DMCA takedown notices. Please send a formal DMCA Takedown Notice to Mass Integrated Systems, Inc. • 18 Henry Graf Jr. Road, Unit 1 • Newburyport, MA 01950.



Product Specification

AU OPTRONICS CORPORATION B156XW01

(✓) Preliminary Specifications

() Final Specifications

| | |
|-------------------|--------------------------|
| Module | 15.6" WXGA Color TFT-LCD |
| Model Name | B156XW01 V0 (H/W 0A) |

| | |
|----------------------------------------------------------------------|-------------|
| Customer | Date |
| | |
| Checked & Approved by | Date |
| _____ | _____ |
| <p>Note: This Specification is subject to change without notice.</p> | |

| | |
|----------------------------------------------------------------------|-------------------|
| Approved by | Date |
| | |
| Prepared by | Date |
| <u>Buffy Chen</u> | <u>11/28/2007</u> |
| <p>NBBU Marketing Division / AU Optronics corporation</p> | |



Contents

| | |
|----------------------------------------------------|-----------|
| 1. Handling Precautions | 4 |
| 2. General Description | 5 |
| 2.1 General Specification..... | 5 |
| 2.2 Optical Characteristics..... | 6 |
| 3. Functional Block Diagram | 11 |
| 4. Absolute Maximum Ratings | 12 |
| 4.1 Absolute Ratings of TFT LCD Module | 12 |
| 4.2 Absolute Ratings of Backlight Unit | 12 |
| 4.3 Absolute Ratings of Environment | 12 |
| 5. Electrical characteristics | 13 |
| 5.1 TFT LCD Module | 13 |
| 5.2 Backlight Unit..... | 15 |
| 6. Signal Characteristic | 17 |
| 6.1 Pixel Format Image | 17 |
| 6.2 The input data format..... | 18 |
| 6.3 Signal Description/Pin Assignment..... | 19 |
| 6.4 Interface Timing | 21 |
| 7. Connector Description | 24 |
| 7.1 TFT LCD Module | 24 |
| 7.2 Backlight Unit..... | 24 |
| 7.3 Signal for Lamp connector | 24 |
| 8. Dynamic Test | 25 |
| 8.1 Vibration Test | 25 |
| 8.2 Shock Test Spec: | 25 |
| 9. Reliability | 26 |
| 10. Mechanical Characteristics | 27 |
| 10.1 LCM Outline Dimension | 27 |
| 10.2 Screw Hole Depth and Center Position | 29 |
| 11. Shipping and Package | 30 |
| 11.1 Shipping Label Format..... | 30 |
| 11.2 Carton package | 31 |
| 11.3 Shipping package of palletizing sequence..... | 31 |
| 12. Appendix: EDID description | 32 |



Product Specification

AU OPTRONICS CORPORATION B156XW01

Record of Revision

| Version and Date | Page | Old description | New Description | Remark |
|------------------|------|-----------------|-----------------|--------|
| 0.1 2007/11/28 | All | Initial Edition | | |



1. Handling Precautions

- 1) Since front polarizer is easily damaged, pay attention not to scratch it.
- 2) Be sure to turn off power supply when inserting or disconnecting from input connector.
- 3) Wipe off water drop immediately. Long contact with water may cause discoloration or spots.
- 4) When the panel surface is soiled, wipe it with absorbent cotton or other soft cloth.
- 5) Since the panel is made of glass, it may break or crack if dropped or bumped on hard surface.
- 6) Since CMOS LSI is used in this module, take care of static electricity and insure human earth when handling.
- 7) Do not open nor modify the Module Assembly.
- 8) Do not press the reflector sheet at the back of the module to any directions.
- 9) In case if a Module has to be put back into the packing container slot after once it was taken out from the container, do not press the center of the CCFL Reflector edge. Instead, press at the far ends of the CCFL Reflector edge softly. Otherwise the TFT Module may be damaged.
- 10) At the insertion or removal of the Signal Interface Connector, be sure not to rotate nor tilt the Interface Connector of the TFT Module.
- 11) After installation of the TFT Module into an enclosure (Notebook PC Bezel, for example), do not twist nor bend the TFT Module even momentary. At designing the enclosure, it should be taken into consideration that no bending/twisting forces are applied to the TFT Module from outside. Otherwise the TFT Module may be damaged.
- 12) Cold cathode fluorescent lamp (CCFL) in LCD contains a small amount of mercury. Please follow local ordinances or regulations for disposal.
- 13) Small amount of materials having no flammability grade is used in the LCD module. The LCD module should be supplied by power complied with requirements of Limited Power Source (IEC60950 or UL1950), or be applied exemption.
- 14) The LCD module is designed so that the CCFL in it is supplied by Limited Current Circuit (IEC60950 or UL1950). Do not connect the CCFL in Hazardous Voltage Circuit.



2. General Description

B156XW01 V0 is a Color Active Matrix Liquid Crystal Display composed of a TFT LCD panel, a driver circuit, and backlight system. The screen format is intended to support the WXGA (1366(H) x 768(V)) screen and 262k colors (RGB 6-bits data driver) without backlight inverter. All input signals are LVDS interface compatible.

B156XW01 V0 is designed for a display unit of notebook style personal computer and industrial machine.

2.1 General Specification

The following items are characteristics summary on the table at 25 °C condition:

| Items | Unit | Specifications | | | | | | | | | | | | | | | | |
|------------------------------------------------------------------------|----------------------|------------------------------------------------------------------------------------------------------------------------------------------------------------------------------------------------------------------------------------------------------------------------------------------------------------------|-------|-------|-----|---|-----|-------|-------|-----|---------|-------|-------|--|-----|--|--|--|
| Screen Diagonal | [mm] | 394.9(15.6"W) | | | | | | | | | | | | | | | | |
| Active Area | [mm] | 344.232(H) X 193.536(V) | | | | | | | | | | | | | | | | |
| Pixels H x V | | 1366x3(RGB) x 768 | | | | | | | | | | | | | | | | |
| Pixel Pitch | [mm] | 0.255X0.255 | | | | | | | | | | | | | | | | |
| Pixel Format | | R.G.B. Vertical Stripe | | | | | | | | | | | | | | | | |
| Display Mode | | Normally White | | | | | | | | | | | | | | | | |
| White Luminance (ICCFL=6.5mA) Note: ICCFL is lamp current | [cd/m ²] | 220 typ. (5 points average) TBD min. (5 points average) (Note1) | | | | | | | | | | | | | | | | |
| Luminance Uniformity | | 1.25 max. (5 points) | | | | | | | | | | | | | | | | |
| Contrast Ratio | | 400 min | | | | | | | | | | | | | | | | |
| Response Time | [ms] | 8 typ / 15 Max | | | | | | | | | | | | | | | | |
| Nominal Input Voltage VDD | [Volt] | +3.3 typ. | | | | | | | | | | | | | | | | |
| Power Consumption | [Watt] | 7 max. (Include Logic and Backlight) | | | | | | | | | | | | | | | | |
| Weight | [Grams] | 550 max. | | | | | | | | | | | | | | | | |
| Physical Size | [mm] | <table border="1"> <thead> <tr> <th></th> <th>L</th> <th>W</th> <th>T</th> </tr> </thead> <tbody> <tr> <td>Max</td> <td>359.8</td> <td>210.0</td> <td>6.4</td> </tr> <tr> <td>Typical</td> <td>359.3</td> <td>209.5</td> <td></td> </tr> <tr> <td>Min</td> <td></td> <td></td> <td></td> </tr> </tbody> </table> | | L | W | T | Max | 359.8 | 210.0 | 6.4 | Typical | 359.3 | 209.5 | | Min | | | |
| | | | L | W | T | | | | | | | | | | | | | |
| | | Max | 359.8 | 210.0 | 6.4 | | | | | | | | | | | | | |
| | | Typical | 359.3 | 209.5 | | | | | | | | | | | | | | |
| Min | | | | | | | | | | | | | | | | | | |
| Electrical Interface | | 1 channel LVDS | | | | | | | | | | | | | | | | |
| Surface Treatment | | Glare, Hardness | | | | | | | | | | | | | | | | |
| Support Color | | 262K colors (RGB 6-bit) | | | | | | | | | | | | | | | | |
| Temperature Range | | | | | | | | | | | | | | | | | | |
| Operating | [°C] | 0 to +50 | | | | | | | | | | | | | | | | |
| Storage (Non-Operating) | [°C] | -20 to +60 | | | | | | | | | | | | | | | | |
| RoHS Compliance | | RoHS Compliance | | | | | | | | | | | | | | | | |



Product Specification

AU OPTRONICS CORPORATION B156XW01

2.2 Optical Characteristics

The optical characteristics are measured under stable conditions at 25°C (Room Temperature) :

| Item | Unit | Conditions | Min. | Typ. | Max. | Note |
|-------------------------------------------------|----------------------|--------------------------------------|-------|-------|-------|----------|
| White Luminance ICCFL=6.5mA | [cd/m ²] | 5 points average | TBD | 220 | - | 1, 4, 5. |
| Viewing Angle | [degree] | Horizontal (Right) CR = 10 (Left) | 40 | 45 | - | 8 |
| | [degree] | | 40 | 45 | - | |
| | [degree] | Vertical (Upper) CR = 10 (Lower) | 10 | 15 | - | |
| | [degree] | | 20 | 35 | - | |
| Luminance Uniformity | | 5 Points | - | - | 1.25 | 1 |
| Luminance Uniformity | | 13 Points | - | - | | 2 |
| CR: Contrast Ratio | | | 400 | 500 | - | 6 |
| Cross talk | % | | | | TBD | 7 |
| Response Time | [msec] | Rising | - | - | - | 8 |
| | [msec] | Falling | - | - | - | |
| | [msec] | Rising + Falling | - | 8 | 15 | |
| Chromaticity of color Coordinates (CIE 1931) | | Red x | TBD | TBD | TBD | 2,8 |
| | | Red y | TBD | TBD | TBD | |
| | | Green x | TBD | TBD | TBD | |
| | | Green y | TBD | TBD | TBD | |
| | | Blue x | TBD | TBD | TBD | |
| | | Blue y | TBD | TBD | TBD | |
| | | White x | 0.283 | 0.313 | 0.343 | |
| | | White y | 0.299 | 0.329 | 0.359 | |
| NTSC | % | CIE 1931 | - | 60 | - | |

Note 1: 5 points position (Ref: Active area)

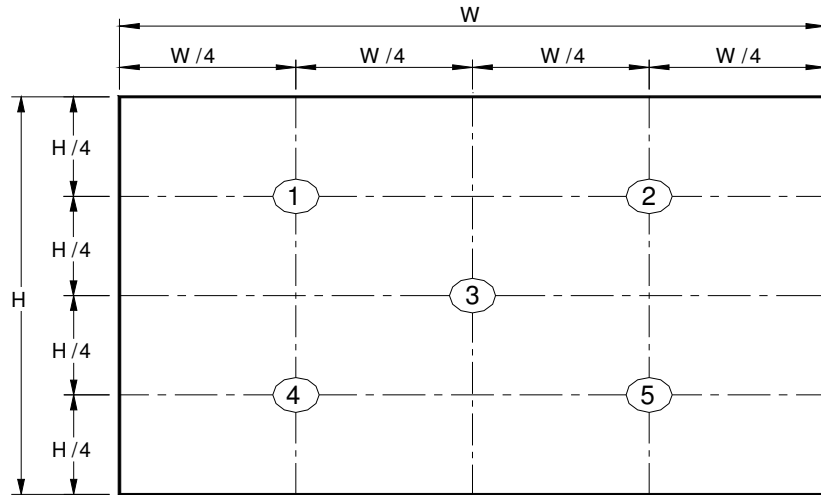

Note 2: 13 points position (Ref: Active area)

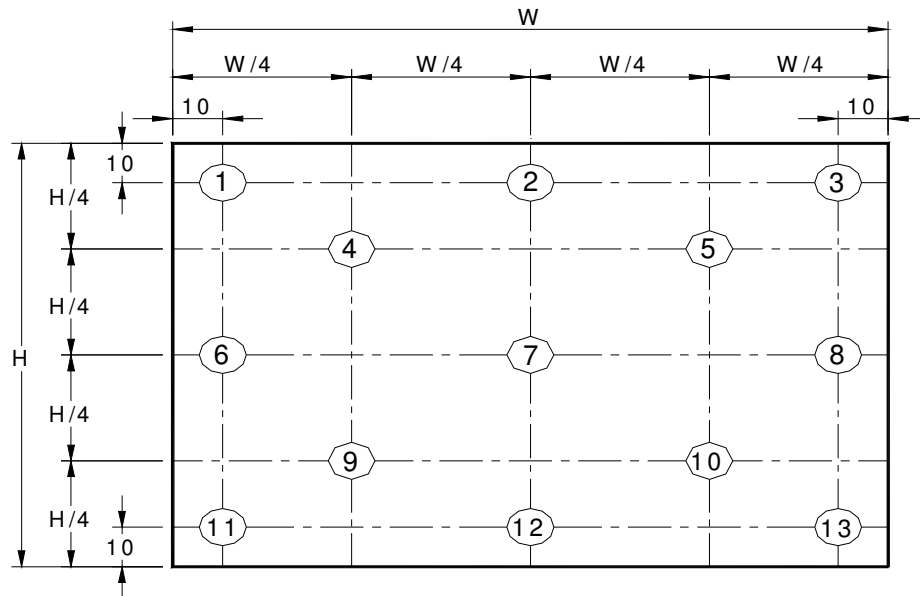

Note 3: The luminance uniformity of 5 or 13 points is defined by dividing the maximum luminance values by the minimum test point luminance

$$\delta_{w5} = \frac{\text{Maximum Brightness of five points}}{\text{Minimum Brightness of five points}}$$

$$\delta_{w13} = \frac{\text{Maximum Brightness of thirteen points}}{\text{Minimum Brightness of thirteen points}}$$

Note 4: Measurement method

The LCD module should be stabilized at given temperature for 30 minutes to avoid abrupt temperature change during measuring. In order to stabilize the luminance, the measurement should be executed after lighting Backlight for 30 minutes in a stable, windless and dark room.

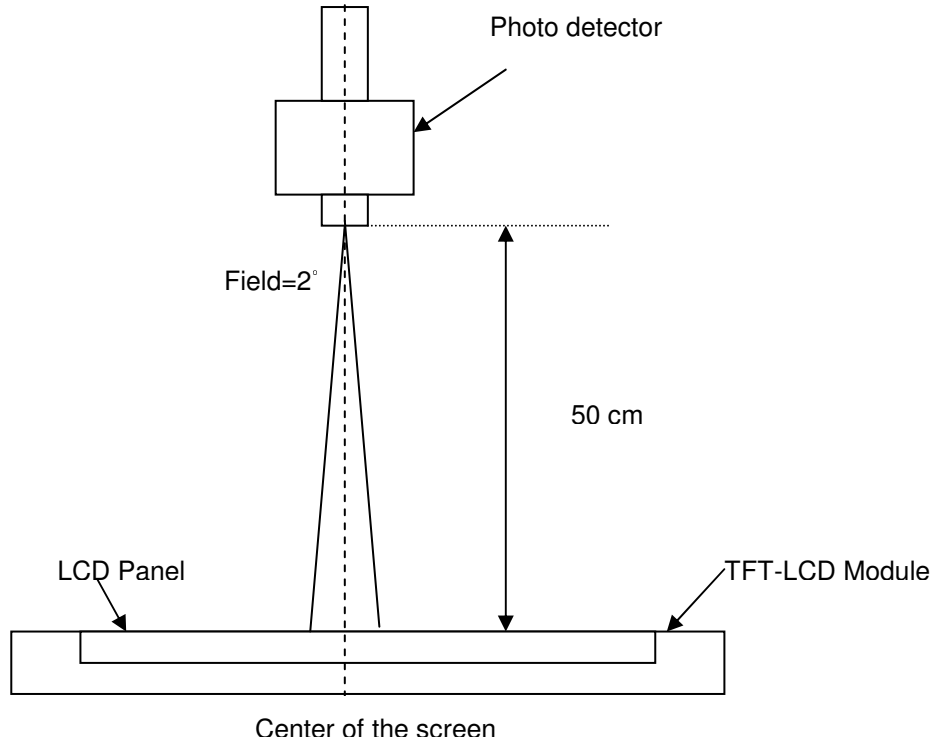

Note 5 : Definition of Average Luminance of White (Y_L):

Measure the luminance of gray level 63 at 5 points · Y_L = [L (1)+ L (2)+ L (3)+ L (4)+ L (5)] / 5

L (x) is corresponding to the luminance of the point X at Figure in Note (1).

Note 6 : Definition of contrast ratio:

Contrast ratio is calculated with the following formula.

$$\text{Contrast ratio (CR)} = \frac{\text{Brightness on the "White" state}}{\text{Brightness on the "Black" state}}$$

Note 7 : Definition of Cross Talk (CT)

$$CT = | Y_B - Y_A | / Y_A \times 100 (\%)$$

Where

Y_A = Luminance of measured location without gray level 0 pattern (cd/m²)

Y_B = Luminance of measured location with gray level 0 pattern (cd/m²)

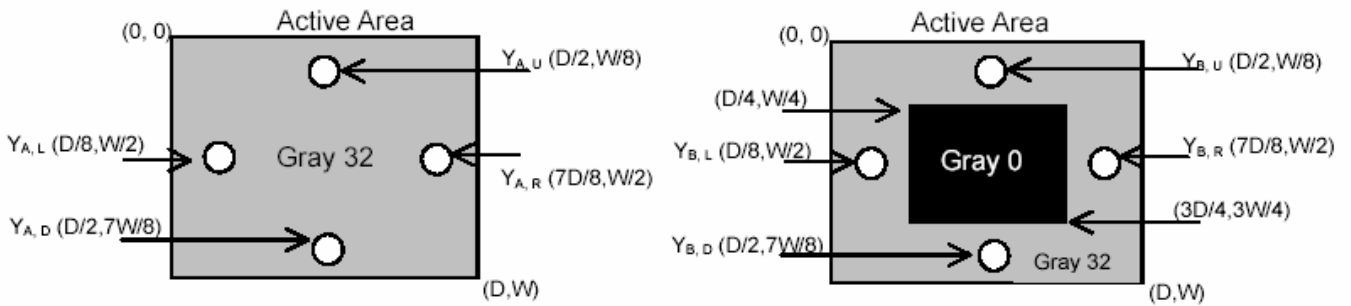

Note 8: Definition of response time:

The output signals of BM-7 or equivalent are measured when the input signals are changed from "Black" to "White" (falling time) and from "White" to "Black" (rising time), respectively. The response time interval between the 10% and 90% of amplitudes. Refer to figure as below.

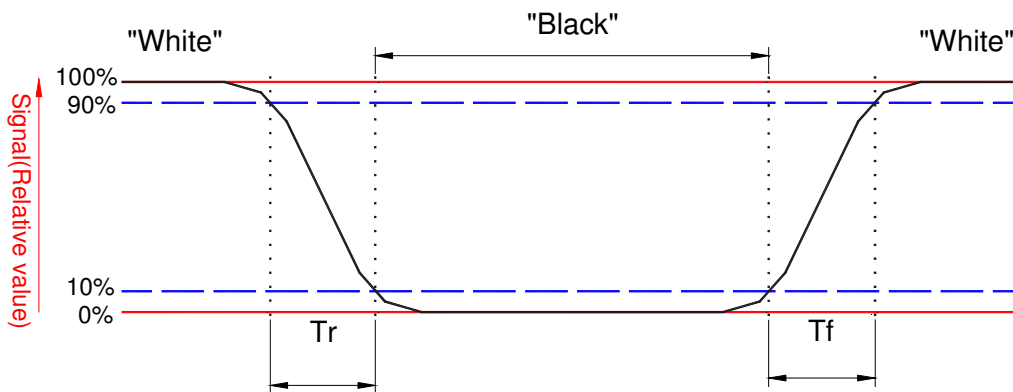

Note 8. Definition of viewing angle

Viewing angle is the measurement of contrast ratio ≥ 10 , at the screen center, over a 180° horizontal and 180° vertical range (off-normal viewing angles). The 180° viewing angle range is broken down as follows; 90° (θ) horizontal left and right and 90° (ϕ) vertical, high (up) and low (down). The measurement direction is typically perpendicular to the display surface with the screen rotated about its center to develop the desired measurement viewing angle.

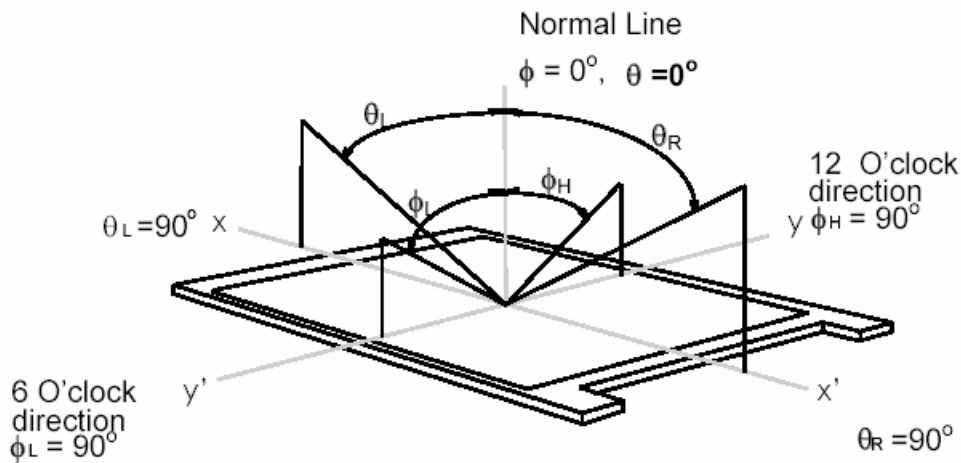

3. Functional Block Diagram

The following diagram shows the functional block of the 15.6 inches wide Color TFT/LCD Module:

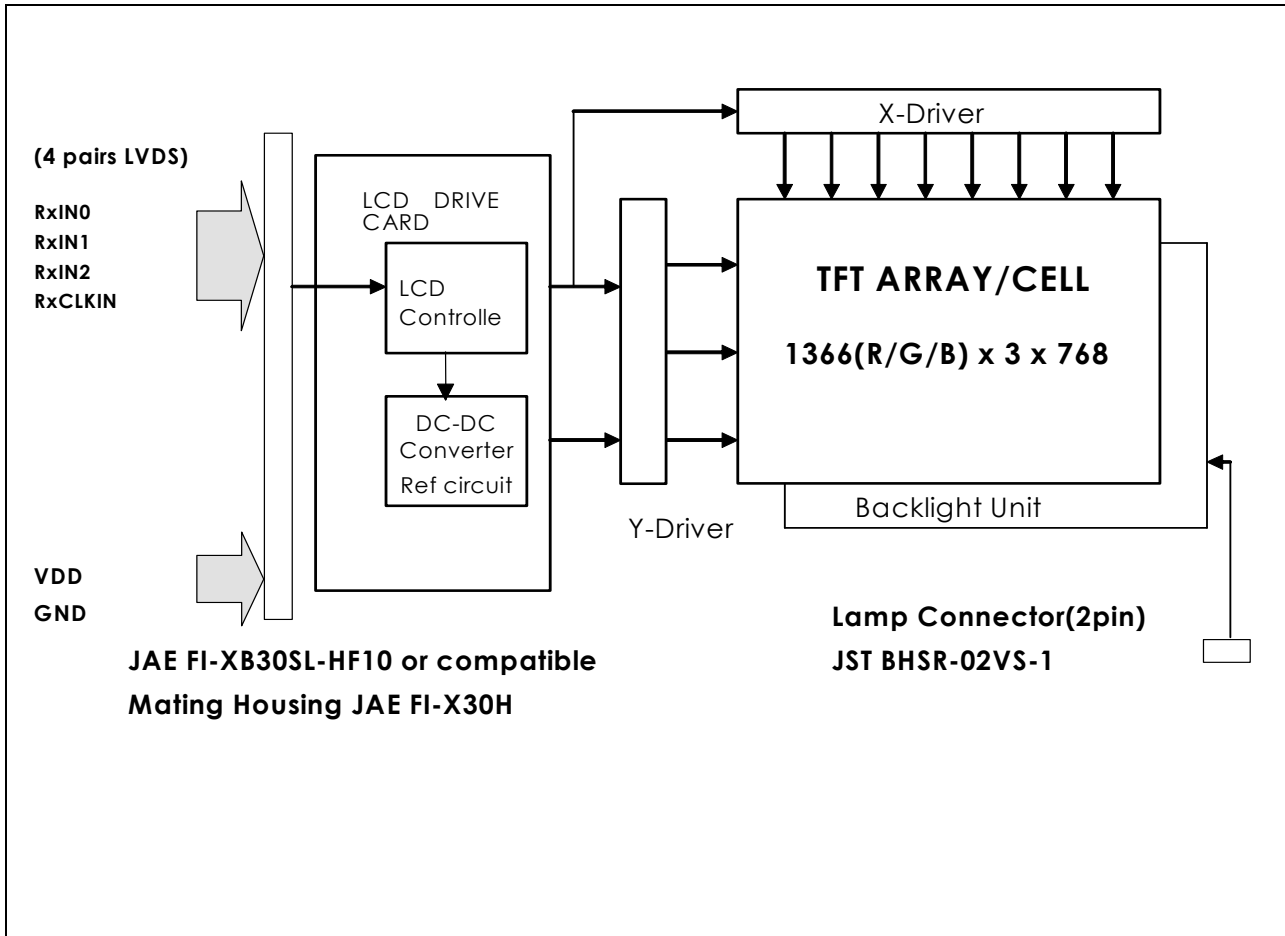

4. Absolute Maximum Ratings

An absolute maximum rating of the module is as following:

4.1 Absolute Ratings of TFT LCD Module

| Item | Symbol | Min | Max | Unit | Conditions |
|-----------------|--------|------|------|--------|------------|
| Logic/LCD Drive | Vin | -0.3 | +4.0 | [Volt] | Note 1,2 |

4.2 Absolute Ratings of Backlight Unit

| Item | Symbol | Min | Max | Unit | Conditions |
|--------------|--------|-----|-----|----------|------------|
| CCFL Current | ICCFL | - | 6.0 | [mA] rms | Note 1,2 |

4.3 Absolute Ratings of Environment

| Item | Symbol | Min | Max | Unit | Conditions |
|---------------------|--------|-----|-----|-------|------------|
| Operating | TOP | 0 | +50 | [°C] | Note 3 |
| Operation Humidity | HOP | 5 | 95 | [%RH] | Note 3 |
| Storage Temperature | TST | -20 | +60 | [°C] | Note 3 |
| Storage Humidity | HST | 5 | 95 | [%RH] | Note 3 |

Note 1: At Ta (25°C)

Note 2: Permanent damage to the device may occur if exceed maximum values

Note 3: For quality performance, please refer to AUO IIS (Incoming Inspection Standard).

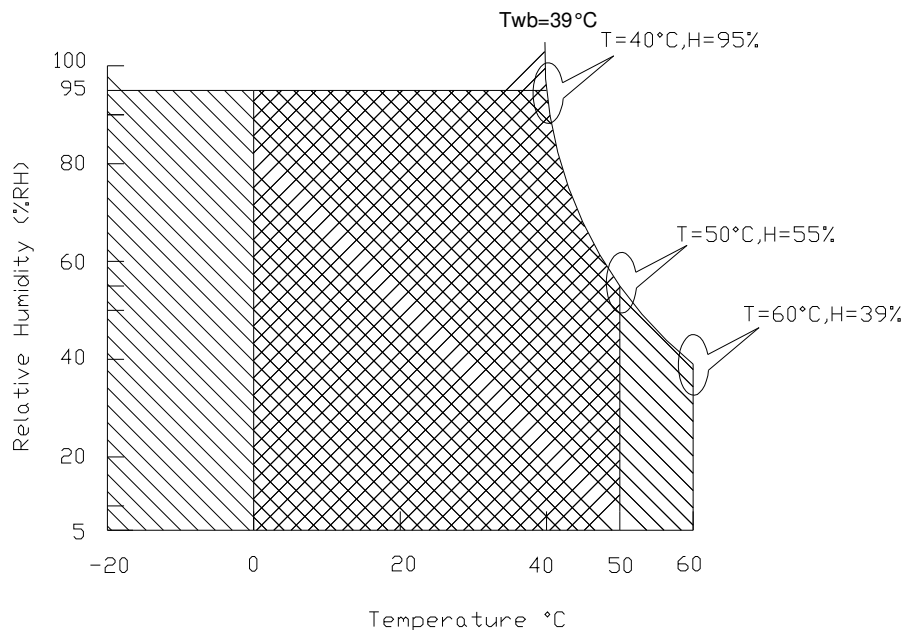

Operating Range 

Storage Range  + 

5. Electrical characteristics

5.1 TFT LCD Module

5.1.1 Power Specification

Input power specifications are as follows;

| Symble | Parameter | Min | Typ | Max | Units | Note |
|--------|------------------------------------------|-----|-----|-----|----------|----------|
| VDD | Logic/LCD Drive Voltage | 3.0 | 3.3 | 3.6 | [Volt] | |
| PDD | VDD Power | | | TBD | [Watt] | Note 1/2 |
| IDD | IDD Current | | TBD | TBD | [mA] | Note 1/2 |
| IRush | Inrush Current | | | TBD | [mA] | Note 3 |
| VDDrp | Allowable Logic/LCD Drive Ripple Voltage | | | TBD | [mV] p-p | |

Note 1 : Maximum Measurement Condition : Black Pattern

Note 2 : Typical Measurement Condition: Mosaic Pattern

Note 3 : Measure Condition

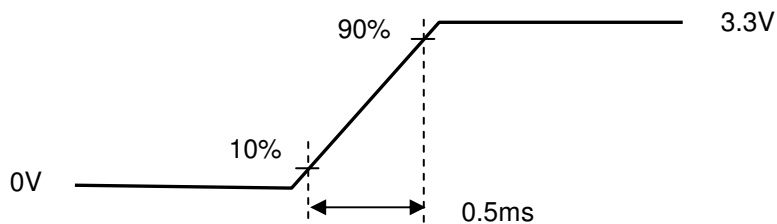
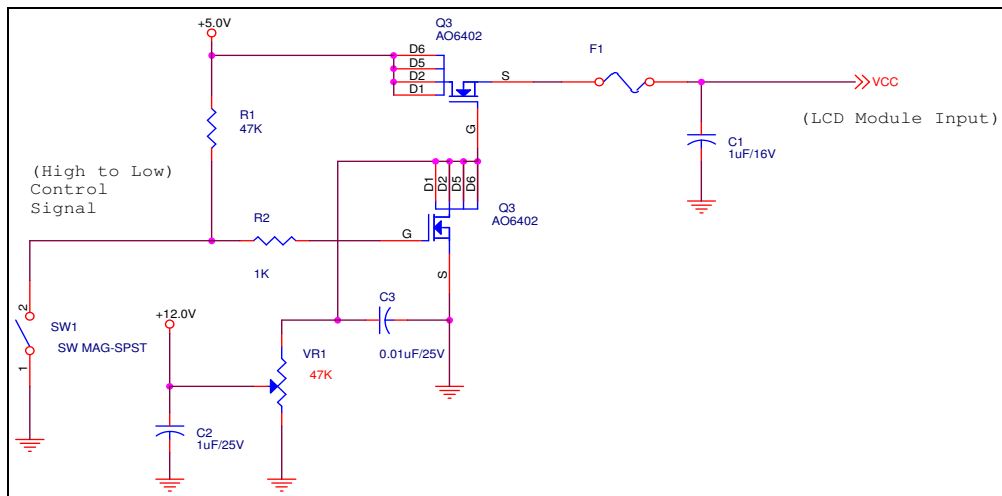

5.1.2 Signal Electrical Characteristics

Input signals shall be low or High-impedance state when VDD is off.

It is recommended to refer the specifications of THC63LVDF84A (Thine Electronics Inc.) in detail.

Signal electrical characteristics are as follows;

| Parameter | Condition | Min | Max | Unit |
|-----------|--------------------------------------------------|-------|-------|------|
| Vth | Differential Input High Threshold (Vcm=+1.2V) | - | 100 | [mV] |
| Vtl | Differential Input Low Threshold (Vcm=+1.2V) | -100 | - | [mV] |
| Vcm | Differential Input Common Mode Voltage | 1.125 | 1.375 | [V] |

Note: LVDS Signal Waveform

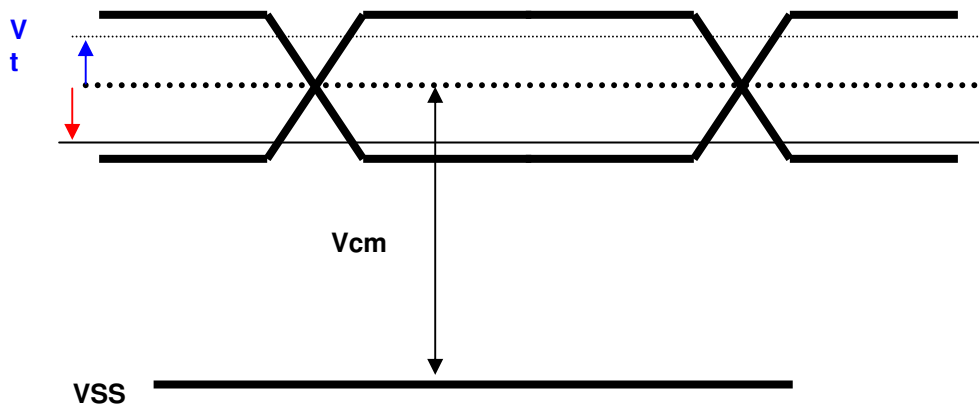

5.2 Backlight Unit

CCFL Parameter guideline for CCFL Inverter selection (Ref. Remark 1)

| Parameter | Min | Typ | Max | Units | Condition |
|-----------------------------------------------------|--------|-----|-----|---------------|------------------------------------|
| CCFL current(I _{CCFL}) | 4.0 | 6.5 | 7.0 | [mA] rms | (T _a =25°C) Note 1 |
| CCFL Frequency(F _{CCFL}) | TBD | TBD | TBD | [KHz] | (T _a =25°C) Note 2,3 |
| CCFL startup Voltage(V _s) | -- | TBD | TBD | [Volt] rms | (T _a = 0°C) Note 4 |
| CCFL startup Voltage(V _s) | -- | TBD | TBD | [Volt] rms | (T _a = 25°C) Note 4 |
| CCFL Voltage (Reference) (V _{CCFL}) | TBD | TBD | TBD | [Volt] rms | (T _a =25°C) Note 5 |
| CCFL Power consumption (P _{CCFL}) | TBD | TBD | TBD | [Watt] | (T _a =25°C) Note 5 |
| CCFL Life-Time | 12,000 | - | - | Hour | (T _a =25°C) Note 7 |

To optimun TFT LCD performance, the LAMP inverter PWM Frequesncy define as: 210 +/-5 Hz

Remark 1: Typ are AUO recommended Design Points.

- 1-1 All of characteristics listed are measured under the condition using the AUO Test inverter.
- 1-2 In case of using an inverter other than listed, it is recommended to check the inverter carefully. Sometimes, interfering noise stripes appear on the screen, and substandard luminance or flicker at low power may happen.
- 1-3 In designing an inverter, it is suggested to check safety circuit very carefully. Impedance of CCFL, for instance, becomes more than 1 [M ohm] when CCFL is damaged.
- 1-4 Generally, CCFL has some amount of delay time after applying starting voltage. It is recommended to keep on applying starting voltage for **1 [Sec]** until discharge.
- 1-5 CCFL discharge frequency must be carefully chosen so as not to produce interfering noise stripes on the screen.
- 1-6 Reducing CCFL current increases CCFL discharge voltage and generally increases CCFL discharge frequency. So all the parameters of an inverter should be carefully designed so as not to produce too much leakage current from high-voltage output of the inverter.

Note 1: It should be employed the inverter which has "Duty Dimming", if ICCFL is less than 4mA.

Note 2: CCFL discharge frequency should be carefully determined to avoid interference between inverter and TFT LCD.

Note 3: The frequency range will not affect to lamp life and reliability characteristics.

Note 4: **The output voltage of inverter should be able to give out a power after ballast capacitor , the generating capacity have to be larger than a lamp startup voltage**, otherwise backlight may has blinking for a moment after turns on or can not be turned on.

Note 5: Calculator value for reference ($ICCFL \times VCCFL = PCCFL$)

Note 6: Requirements for a system inverter design, which is intended to have a better display performance, a better power efficiency and a more reliable lamp, are following. It shall help increase the lamp lifetime and reduce leakage current.

a. The asymmetry rate of the inverter waveform should be less than 10%.

b. The distortion rate of the waveform should be within $\sqrt{2} \pm 10\%$.

* Inverter output waveform had better be more similar to ideal sine wave.

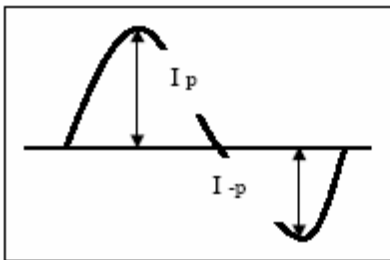

* Asymmetry rate:

$$\frac{|I_p - I_{-p}|}{I_{rms}} * 100\%$$

* Distortion rate

$$I_p \text{ (or } I_{-p}) / I_{rms}$$

Note 7: It is an edge-type BLU with single CCFL, the life-time define as the brightness decay to 50% of original value and under normal operation.

6.2 The input data format

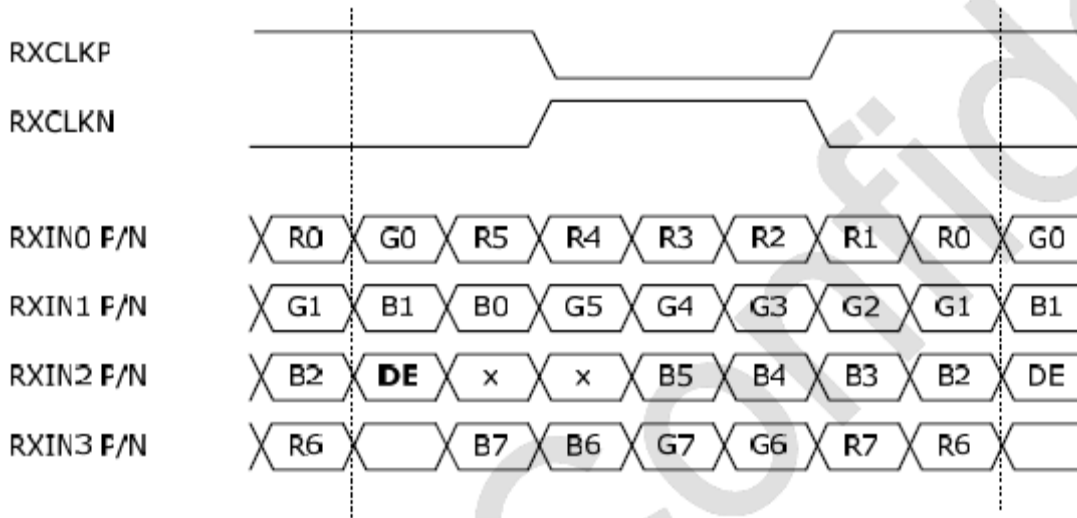

| Signal Name | Description | |
|----------------------------------|-------------------------------------------------------------------------------------------------------------------------------------|--------------------------------------------------------------------------------------------------------------------------------------------------------------------------------------|
| R5 R4 R3 R2 R1 R0 | Red Data 5 (MSB) Red Data 4 Red Data 3 Red Data 2 Red Data 1 Red Data 0 (LSB) Red-pixel Data | Red-pixel Data Each red pixel's brightness data consists of these 6 bits pixel data. |
| G5 G4 G3 G2 G1 G0 | Green Data 5 (MSB) Green Data 4 Green Data 3 Green Data 2 Green Data 1 Green Data 0 (LSB) Green-pixel Data | Green-pixel Data Each green pixel's brightness data consists of these 6 bits pixel data. |
| B5 B4 B3 B2 B1 B0 | Blue Data 5 (MSB) Blue Data 4 Blue Data 3 Blue Data 2 Blue Data 1 Blue Data 0 (LSB) Blue-pixel Data | Blue-pixel Data Each blue pixel's brightness data consists of these 6 bits pixel data. |
| RxCLKIN | Data Clock | The typical frequency is 77.8 MHz. The signal is used to strobe the pixel data and DSPTMG signals. All pixel data shall be valid at the falling edge when the DSPTMG signal is high. |
| DE | Display Timing | This signal is strobed at the falling edge of -DTCLK. When the signal is high, the pixel data shall be valid to be displayed. |
| VS | Vertical Sync | The signal is synchronized to -DTCLK. |
| HS | Horizontal Sync | The signal is synchronized to -DTCLK. |

Note: Output signals from any system shall be low or High-Z state when VDD is off.



6.3 Signal Description/Pin Assignment

LVDS is a differential signal technology for LCD interface and high speed data transfer device.

| PIN # | SIGNAL NAME | DESCRIPTION |
|-------|----------------------|--------------------------------|
| 1 | VSS | Power Ground |
| 2 | VDD | + 3.3V Power Supply |
| 3 | VDD | + 3.3V Power Supply |
| 4 | V _{EDID} | + 3.3V EDID Power |
| 5 | AGING | Aging Mode Power Supply |
| 6 | CLK _{EDID} | EDID Clock Input |
| 7 | DATA _{EDID} | EDID Data Input |
| 8 | RXIN0N | -LVDS Differential Data Input |
| 9 | RXIN0P | +LVDS Differential Data Input |
| 10 | VSS | Power Ground |
| 11 | RXIN1N | -LVDS Differential Data Input |
| 12 | RXIN1P | +LVDS Differential Data Input |
| 13 | VSS | Power Ground |
| 14 | RXIN2N | -LVDS Differential Data Input |
| 15 | RXIN2P | +LVDS Differential Data Input |
| 16 | VSS | Power Ground |
| 17 | CK1INN | -LVDS Differential Clock Input |
| 18 | CK1INP | +LVDS Differential Clock Input |
| 19 | VSS | Power Ground |
| 20 | X | --- |
| 21 | X | --- |
| 22 | VSS | Power Ground |
| 23 | X | --- |
| 24 | X | --- |
| 25 | VSS | Power Ground |
| 26 | X | --- |
| 27 | X | --- |
| 28 | VSS | Power Ground |
| 29 | X | --- |
| 30 | X | --- |

Note1: Start from right side

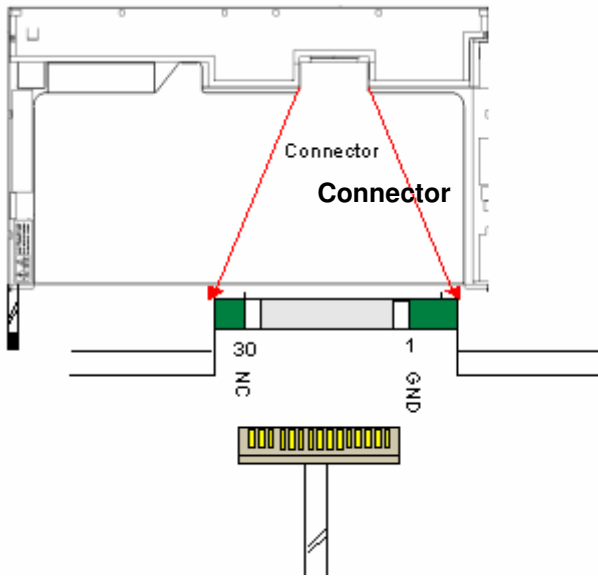

Note2: Input signals shall be low or High-impedance state when VDD is off.
internal circuit of LVDS inputs are as following.

The module uses a 100ohm resistor between positive and negative data lines of each receiver input

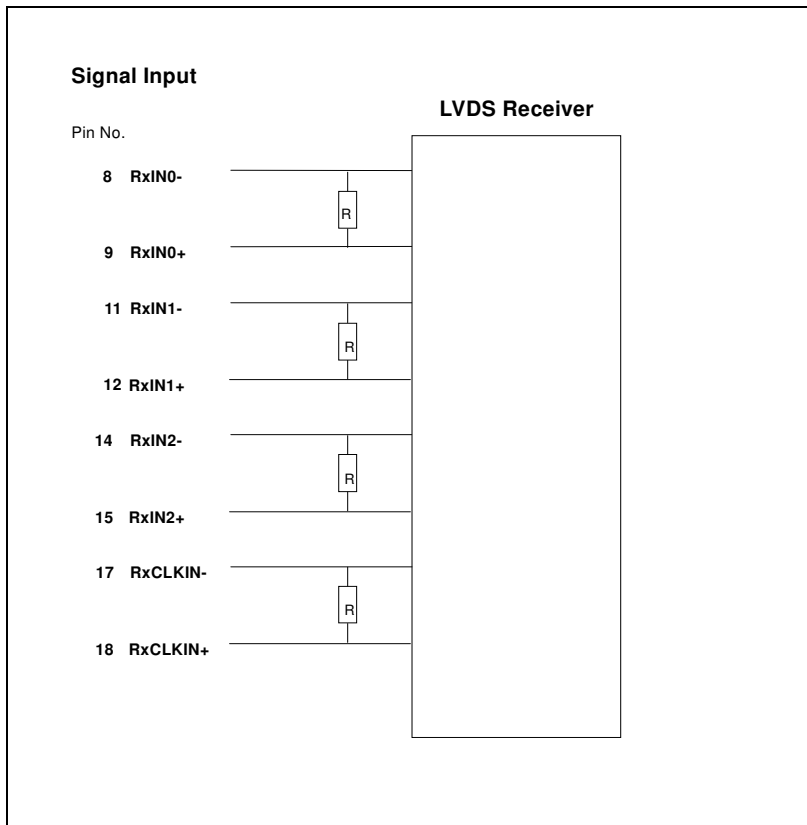

6.4 Interface Timing

6.4.1 Timing Characteristics

Basically, interface timings should match the 1366x768 /60Hz manufacturing guide line timing.

| Parameter | Symbol | Min. | Typ. | Max. | Unit | |
|--------------------|-----------------------|-----------------|------|------|------|--------------------|
| Frame Rate | - | - | 60 | - | Hz | |
| Clock frequency | 1/ T _{clock} | 65 | 77.8 | 90 | MHz | |
| Vertical Section | Period | T _V | 776 | 808 | 1023 | T _{Line} |
| | Active | T _{VD} | 768 | 768 | 768 | |
| | Blanking | T _{VB} | 8 | 40 | 255 | |
| Horizontal Section | Period | T _H | 1396 | 1606 | 2047 | T _{clock} |
| | Active | T _{HD} | 1366 | 1366 | 1366 | |
| | Blanking | T _{HB} | 30 | 240 | 681 | |

Note : DE mode only

6.4.2 Timing diagram

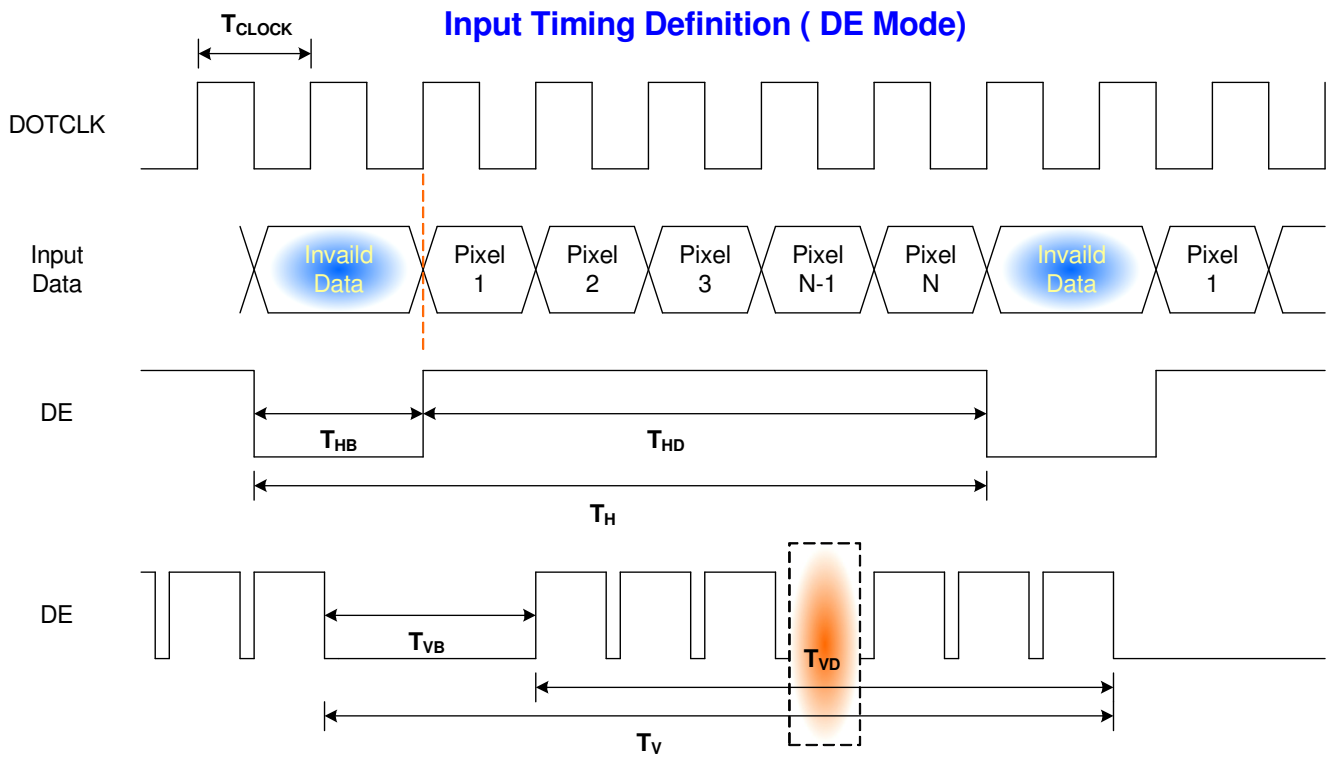

6.5 Power ON/OFF Sequence

VDD power and lamp on/off sequence is as follows. Interface signals are also shown in the chart. Signals from any system shall be Hi-Z state or low level when VDD is off.

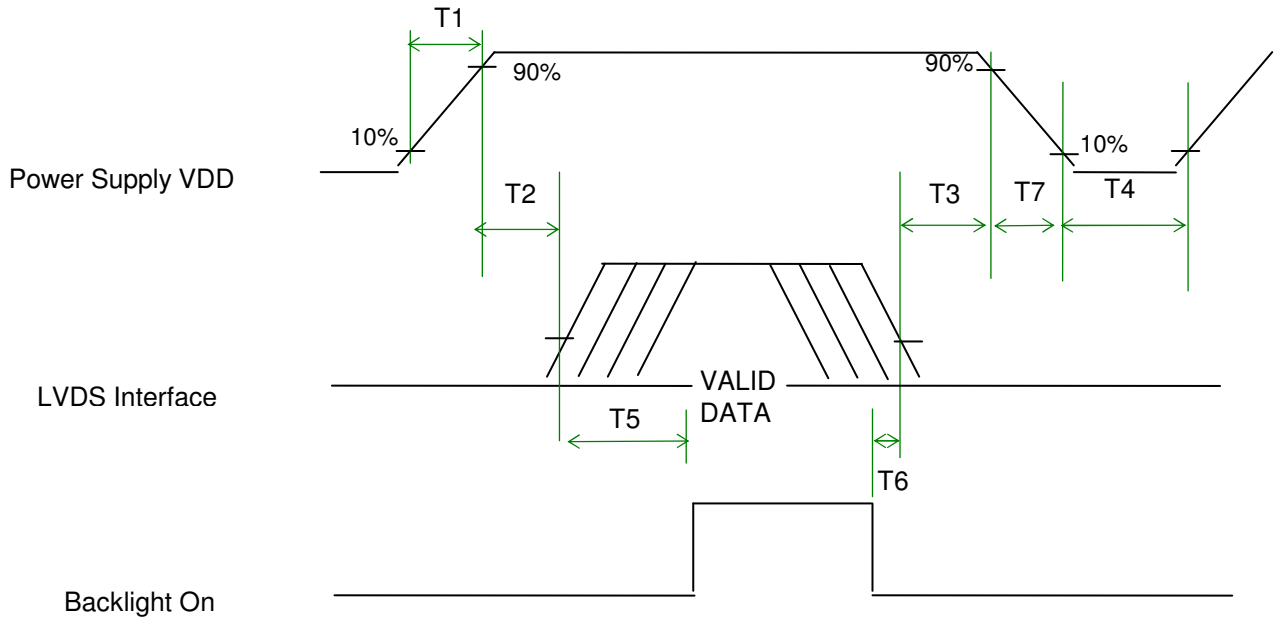

Timing

| Parameter | Value | | | Units |
|-----------|-------|------|------|-------|
| | Min. | Typ. | Max. | |
| T1 | 0.5 | - | 10 | (ms) |
| T2 | 0 | - | 50 | (ms) |
| T3 | 0 | - | 50 | (ms) |
| T4 | 400 | - | - | (ms) |
| T5 | 200 | - | - | (ms) |
| T6 | 200 | - | - | (ms) |
| T7 | 0 | - | 10 | (ms) |

Power Sequence

7. Connector Description

Physical interface is described as for the connector on module.

These connectors are capable of accommodating the following signals and will be following components.

7.1 TFT LCD Module

| | |
|------------------------------|----------------------------|
| Connector Name / Designation | For Signal Connector |
| Manufacturer | JAE or compatible |
| Type / Part Number | JAE, FI-XB30SL-HF10 |
| Mating Housing/Part Number | |

7.2 Backlight Unit

Physical interface is described as for the connector on module.

These connectors are capable of accommodating the following signals and will be following components.

| | |
|------------------------------|------------------------|
| Connector Name / Designation | For Lamp Connector |
| Manufacturer | JST |
| Type / Part Number | BHSR-02VS-1 |
| Mating Type / Part Number | SM02B-BHSS-1-TB |

7.3 Signal for Lamp connector

| Pin # | Cable color | Signal Name |
|-------|-------------|-------------------|
| 1 | Pink | Lamp High Voltage |
| 2 | White | Lamp Low Voltage |

8. Dynamic Test

8.1 Vibration Test

Test condition:

- Acceleration: 1.5 G
- Frequency: 10 - 500Hz Random
- Sweep: 30 Minutes each Axis (X, Y, Z)

8.2 Shock Test Spec:

Test condition:

- Acceleration: 220 G , Half sine wave
- Active time: 2 ms
- Pulse: +/-X,+/-Y,+/-Z , one time for each side

Remark:

1. Ambient condition is $25 \pm 5^{\circ}\text{C}$, Relative humidity : 40% ~ 70%
2. Non-packaged and Non-operation

9. Reliability

| Items | Required Condition | Note |
|----------------------------|--------------------------------------------------|--------|
| Temperature Humidity Bias | Ta= 40°C, 90%RH, 300h | |
| High Temperature Operation | Ta= 50°C, Dry, 300h | |
| Low Temperature Operation | Ta= 0°C, 300h | |
| High Temperature Storage | Ta= 60°C, 35%RH, 300h | |
| Low Temperature Storage | Ta= -20°C, 50%RH, 300h | |
| Thermal Shock Test | Ta=-20°C to 60°C, Duration at 30 min, 100 cycles | |
| ESD | Contact : ±8 KV Air : ±15 KV | Note 1 |

Note1: According to EN 61000-4-2 , ESD class B: Some performance degradation allowed. No data lost . Self-recoverable. No hardware failures.

Remark: MTBF (Excluding the CCFL): 30,000 hours with a confidence level 90%

10. Mechanical Characteristics

10.1 LCM Outline Dimension

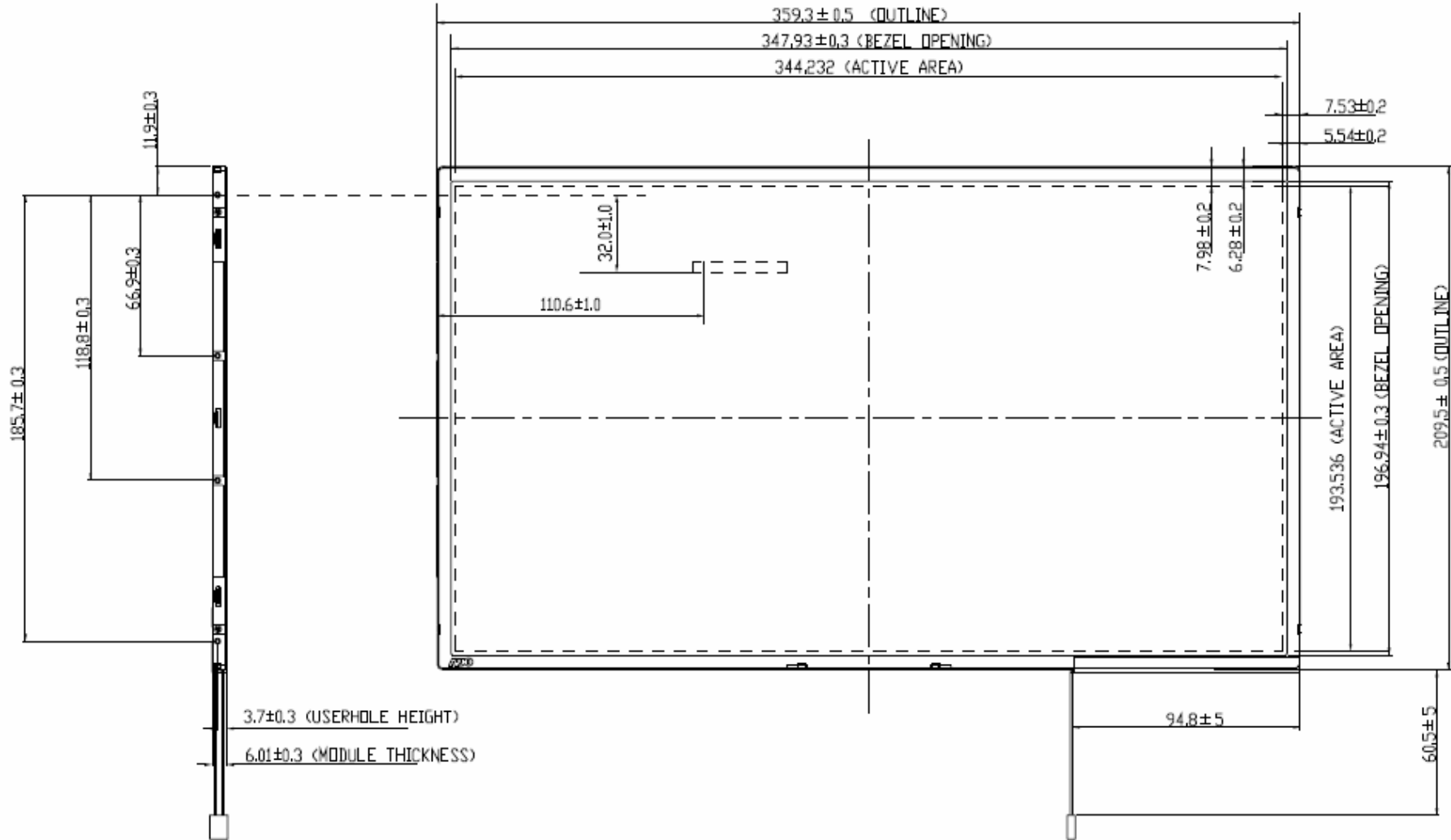



Product Specification

AU OPTRONICS CORPORATION B156XW01

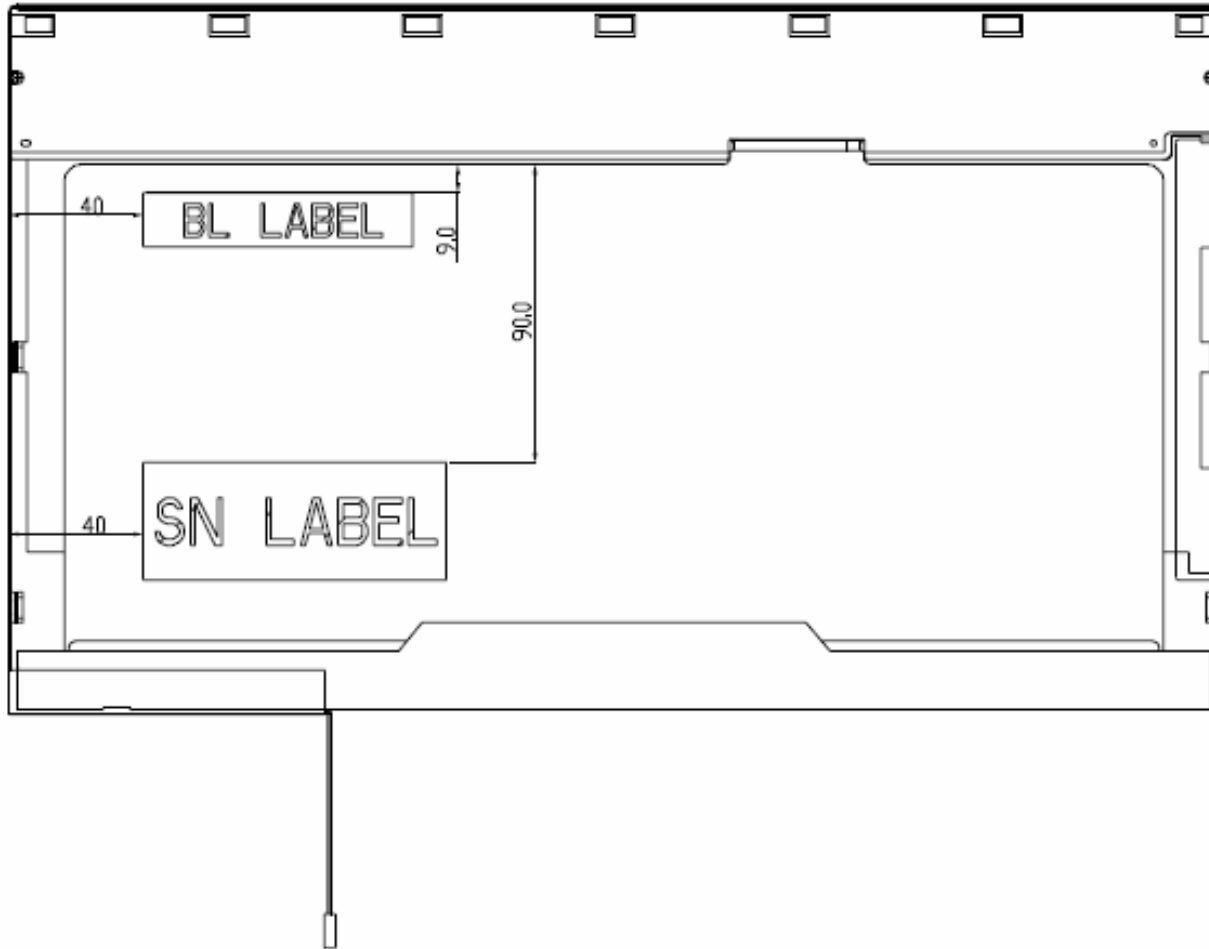



10.2 Screw Hole Depth and Center Position

Screw hole minimum depth, from side surface = 2.6 mm (See drawing)

Screw hole center location, from front surface = 3.7 ± 0.3 mm (See drawing)

Screw maximum length = 2.3 mm (See drawing)

Screw Torque: Maximum 2.5 kgf-cm



Product Specification

AU OPTRONICS CORPORATION B156XW01

11. Shipping and Package

11.1 Shipping Label Format

| | | |
|---------------------------------------------------------------------------------------------------------------|-----------------------------------------------------------------------------------------------------------------------------------------------------------|----------------------------------------------------------------------------------------------------------------------------------------------------------------------------|
|  XXXXXXXXXXXXXXXX-XXXXXX | Manufactured 05/52 Model No: B156XW01 Y0 AU Optronics OAXX6 MADE IN CHINA (S3) H/W: 0A F/W:1 |   |
|  CT: CXXXXXXXXXXXX | | |

11.2 Carton package

The outside dimension of carton is TBD

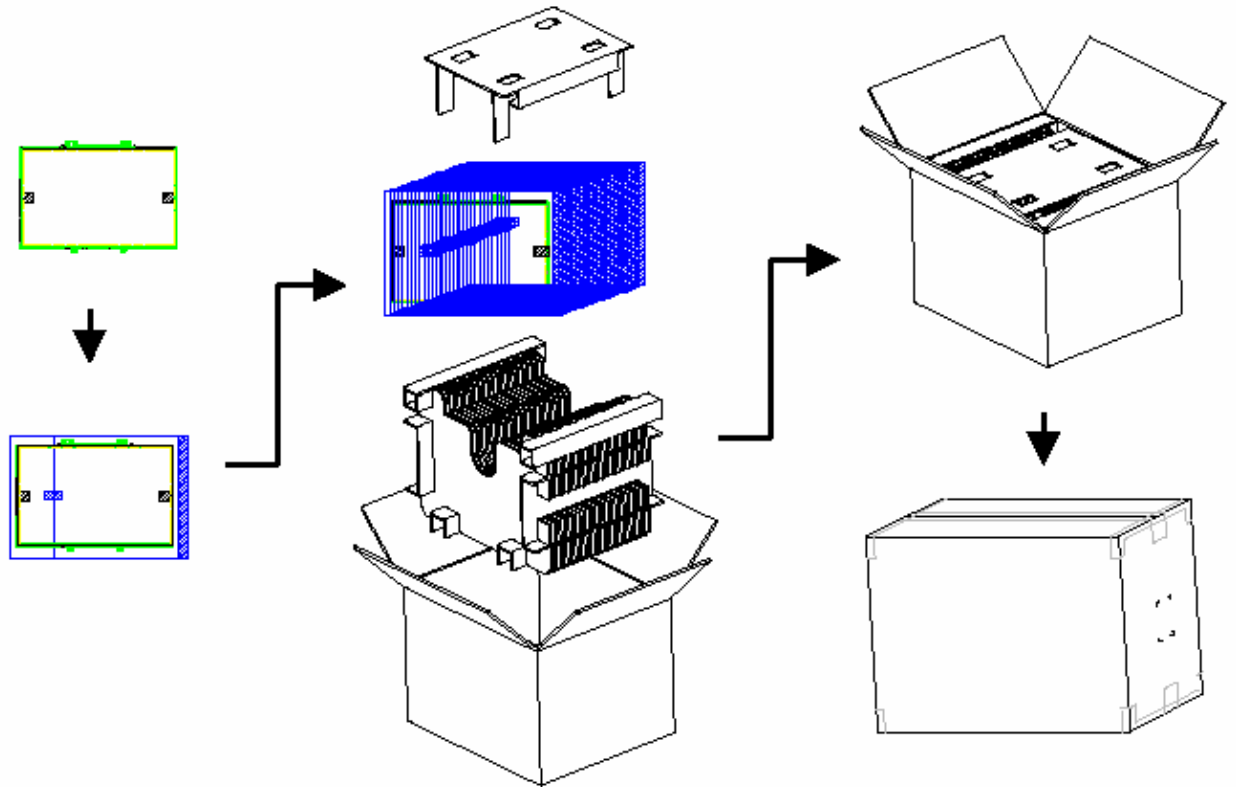

11.3 Shipping package of palletizing sequence

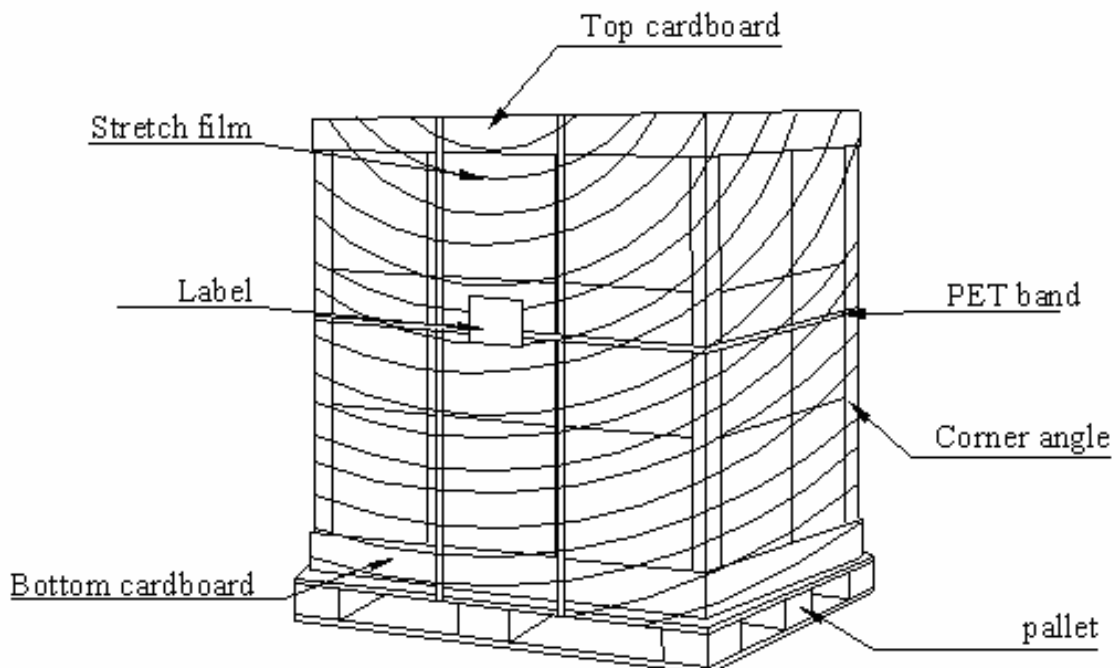



Product Specification

AU OPTRONICS CORPORATION B156XW01

12. Appendix: EDID description

TBD