

# mass integrated

global part distribution • product lifecycle partner  
excess inventory management • value-ad service provider



Data sheet provided by Mass Integrated

[massintegrated.com](http://massintegrated.com) • [displayalliance.com](http://displayalliance.com)

Please call +1.978.465.6190  
Email: [sales@massintegrated.com](mailto:sales@massintegrated.com)



ISO 9001: 2008

Mass Integrated complies with all DMCA takedown notices. Please send a formal DMCA Takedown Notice to Mass Integrated Systems, Inc. • 18 Henry Graf Jr. Road, Unit 1 • Newburyport, MA 01950.



# Product Specification

AU OPTRONICS CORPORATION

( ) Preliminary Specifications

( V ) Final Specifications

<b>Module</b>	<b>15.6”(15.55”) HD 16:9 Color TFT-LCD with LED Backlight design</b>
<b>Model Name</b>	B156XW03 V2 (H/W:0A)
<b>Note</b> (  )	<b><i>LED Backlight with driving circuit design</i></b>

<b>Customer</b>	<b>Date</b>
_____	_____
<b>Checked &amp; Approved by</b>	<b>Date</b>
_____	_____
Note: This Specification is subject to change without notice.	

<b>Approved by</b>	<b>Date</b>
<u>Bonnie Chen</u>	<u>09/16/2009</u>
<b>Prepared by</b>	<b>Date</b>
<u>Derrick Lee</u>	<u>09/16/2009</u>
<b>NBBU Marketing Division AU Optronics corporation</b>	



**Contents**

**1. Handling Precautions ..... 4**

**2. General Description ..... 5**

    2.1 General Specification ..... 5

    2.2 Optical Characteristics ..... 6

**3. Functional Block Diagram ..... 11**

**4. Absolute Maximum Ratings..... 12**

    4.1 Absolute Ratings of TFT LCD Module ..... 12

    4.2 Absolute Ratings of Environment ..... 12

**5. Electrical Characteristics..... 13**

    5.1 TFT LCD Module..... 13

    5.2 Backlight Unit ..... 16

**6. Signal Interface Characteristic..... 17**

    6.1 Pixel Format Image ..... 17

    6.2 The Input Data Format ..... 18

    6.3 Integration Interface Requirement..... 19

    6.4 Interface Timing ..... 21

**7. Panel Reliability Test ..... 23**

    7.1 Vibration Test ..... 23

    7.2 Shock Test ..... 23

    7.3 Reliability Test..... 23

**8. Mechanical Characteristics..... 24**

    8.1 LCM Outline Dimension..... 24

**9. Shipping and Package ..... 26**

    9.1 Shipping Label Format ..... 26

    9.2 Carton Package..... 27

    9.3 Shipping Package of Palletizing Sequence..... 28

**10. Appendix: EDID Description..... 28**



# Product Specification

AU OPTRONICS CORPORATION

## Record of Revision

Version and Date	Page	Old description	New Description	Remark
0.1 2009/04/16	All	First Edition for Customer		
1.0 2009/7/27	All	Preliminary spec	Final spec	
1.1 2009/8/21	26	Shipping label	Adding a check line on shipping label	
1.2 2009/9/16	6	Luminance Uniformity 13 Points (Max): TBD	Luminance Uniformity 13 Points (Max): 1.55	

## 1. Handling Precautions

- 1) Since front polarizer is easily damaged, pay attention not to scratch it.
- 2) Be sure to turn off power supply when inserting or disconnecting from input connector.
- 3) Wipe off water drop immediately. Long contact with water may cause discoloration or spots.
- 4) When the panel surface is soiled, wipe it with absorbent cotton or other soft cloth.
- 5) Since the panel is made of glass, it may break or crack if dropped or bumped on hard surface.
- 6) Since CMOS LSI is used in this module, take care of static electricity and insure human earth when handling.
- 7) Do not open nor modify the Module Assembly.
- 8) Do not press the reflector sheet at the back of the module to any directions.
- 9) At the insertion or removal of the Signal Interface Connector, be sure not to rotate nor tilt the Interface Connector of the TFT Module.
- 11) After installation of the TFT Module into an enclosure (Notebook PC Bezel, for example), do not twist nor bend the TFT Module even momentary. At designing the enclosure, it should be taken into consideration that no bending/twisting forces are applied to the TFT Module from outside. Otherwise the TFT Module may be damaged.
- 12) Small amount of materials having no flammability grade is used in the LCD module. The LCD module should be supplied by power complied with requirements of Limited Power Source (IEC60950 or UL1950), or be applied exemption.
- 13) Disconnecting power supply before handling LCD modules, it can prevent electric shock, DO NOT TOUCH the electrode parts, cables, connectors and LED circuit part of TFT module that a LED light bar build in as a light source of back light unit. It can prevent electrostatic breakdown.

## 2. General Description

B156XW03 V2 is a Color Active Matrix Liquid Crystal Display composed of a TFT LCD panel, a driver circuit, and LED backlight system. The screen format is intended to support the 16:9 HD, 1366(H) x768(V) screen and 262k colors (RGB 6-bits data driver) with LED backlight driving circuit. All input signals are LVDS interface compatible.

B156XW03 V2 is designed for a display unit of notebook style personal computer and industrial machine.

### 2.1 General Specification

The following items are characteristics summary on the table at 25 °C condition:

Items	Unit	Specifications			
Screen Diagonal	[mm]	394.9 (15.55")			
Active Area	[mm]	344.2 x 193.5			
Pixels H x V		1366x3(RGB) x 768			
Pixel Pitch	[mm]	0.252 x 0.252			
Pixel Format		R.G.B. Vertical Stripe			
Display Mode		Normally White			
White Luminance (ILED=20mA) (Note: ILED is LED current)	[cd/m <sup>2</sup> ]	200 typ. (5 points average) 170 min. (5 points average)			
Luminance Uniformity		1.25 max. (5 points)			
Contrast Ratio		500 typ			
Response Time	[ms]	8 typ / 15 Max			
Nominal Input Voltage VDD	[Volt]	+3.3 typ.			
Power Consumption	[Watt]	5.4 max. (Include Logic and BLU power)			
Weight	[Grams]	425 max.			
Physical Size <b>Include bracket</b>	[mm]		Min.	Typ.	Max.
		Length	-	-	360
		Width	-	-	224.3
		Thickness	-	-	3.8
Electrical Interface		1 channel LVDS			
Glass Thickness	[mm]	0.5			
Surface Treatment		Anti-glare			
Support Color		262K colors ( RGB 6-bit )			



# Product Specification

AU OPTRONICS CORPORATION

Temperature Range Operating	[°C]	0 to +50
Storage (Non-Operating)	[°C]	-20 to +60
RoHS Compliance		RoHS Compliance

## 2.2 Optical Characteristics

The optical characteristics are measured under stable conditions at 25°C (Room Temperature) :

Item	Symbol	Conditions	Min.	Typ.	Max.	Unit	Note
<b>White Luminance</b> $I_{LED}=20mA$		<b>5 points average</b>	<b>170</b>	<b>200</b>	<b>-</b>	<b>cd/m<sup>2</sup></b>	1,4,5
<b>Viewing Angle</b>	$\theta_R$ $\theta_L$	<b>Horizontal (Right)</b> <b>CR = 10 (Left)</b>	<b>40</b> <b>40</b>	<b>45</b> <b>45</b>	<b>-</b> <b>-</b>	<b>degree</b>	4,9
	$\psi_H$ $\psi_L$	<b>Vertical (Upper)</b> <b>CR = 10 (Lower)</b>	<b>10</b> <b>30</b>	<b>15</b> <b>35</b>	<b>-</b> <b>-</b>		
<b>Luminance Uniformity</b>	$\delta_{5P}$	<b>5 Points</b>	<b>-</b>	<b>-</b>	<b>1.25</b>		1,3,4
<b>Luminance Uniformity</b>	$\delta_{13P}$	<b>13 Points</b>	<b>-</b>	<b>-</b>	<b>1.55</b>		2,3,4
<b>Contrast Ratio</b>	<b>CR</b>		<b>400</b>	<b>500</b>	<b>-</b>		4,6
<b>Cross talk</b>	%				<b>4</b>		4,7
<b>Response Time</b>	$T_r$	<b>Rising</b>	<b>-</b>	<b>-</b>	<b>-</b>	<b>msec</b>	4,8
	$T_f$	<b>Falling</b>	<b>-</b>	<b>-</b>	<b>-</b>		
	$T_{RT}$	<b>Rising + Falling</b>	<b>-</b>	<b>8</b>	<b>15</b>		
<b>Color / Chromaticity Coordinates</b>	<b>Red</b>	<b>Rx</b>	<b>CIE 1931</b>	<b>0.590</b>	<b>0.620</b>	<b>0.650</b>	4
		<b>Ry</b>		<b>0.310</b>	<b>0.340</b>	<b>0.370</b>	
	<b>Green</b>	<b>Gx</b>		<b>0.300</b>	<b>0.330</b>	<b>0.360</b>	
		<b>Gy</b>		<b>0.540</b>	<b>0.570</b>	<b>0.600</b>	
	<b>Blue</b>	<b>Bx</b>		<b>0.120</b>	<b>0.150</b>	<b>0.180</b>	
		<b>By</b>		<b>0.030</b>	<b>0.060</b>	<b>0.090</b>	
	<b>White</b>	<b>Wx</b>		<b>0.263</b>	<b>0.313</b>	<b>0.363</b>	
		<b>Wy</b>		<b>0.279</b>	<b>0.329</b>	<b>0.379</b>	
<b>NTSC</b>	%		<b>-</b>	<b>60</b>	<b>-</b>		

**Note 1:** 5 points position (Ref: Active area)

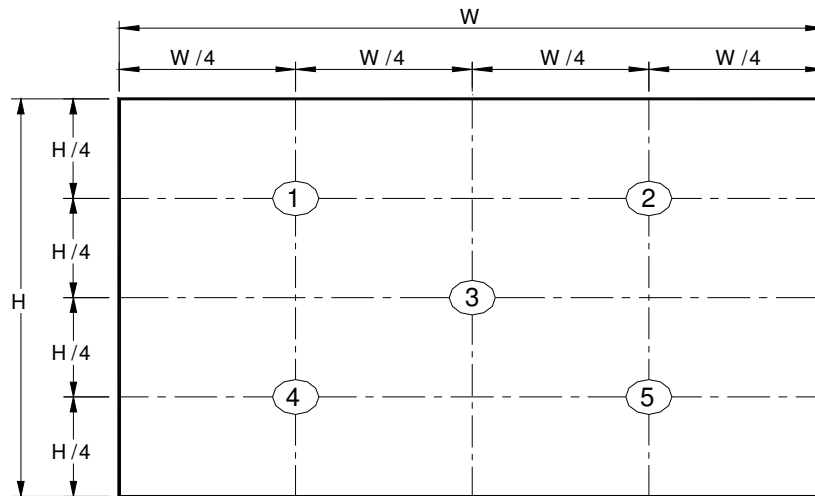

**Note 2:** 13 points position (Ref: Active area)

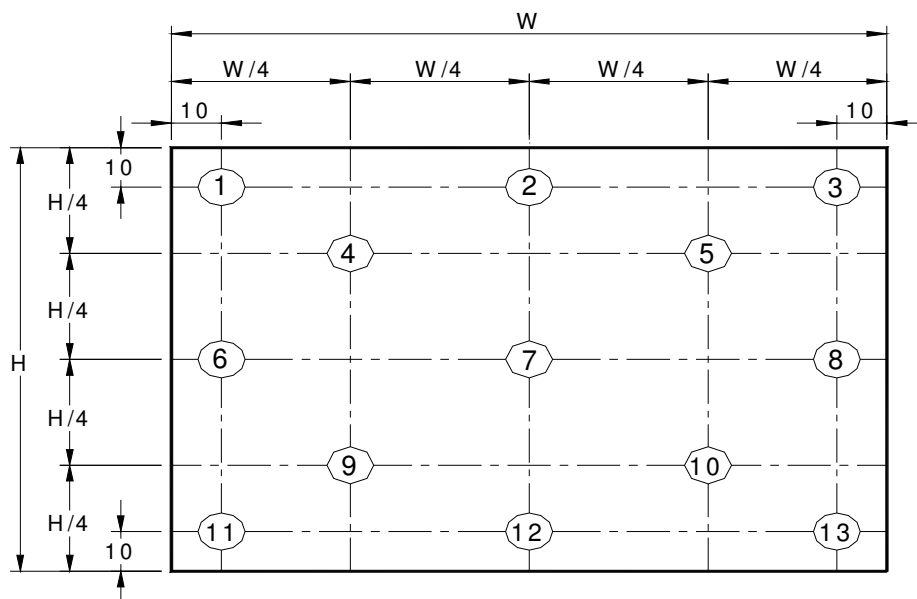

**Note 3:** The luminance uniformity of 5 or 13 points is defined by dividing the maximum luminance values by the minimum test point luminance

$$\delta_{W5} = \frac{\text{Maximum Brightness of five points}}{\text{Minimum Brightness of five points}}$$

$$\delta_{W13} = \frac{\text{Maximum Brightness of thirteen points}}{\text{Minimum Brightness of thirteen points}}$$

**Note 4:** Measurement method

The LCD module should be stabilized at given temperature for 30 minutes to avoid abrupt temperature change during measuring. In order to stabilize the luminance, the measurement should be executed after lighting

Backlight for 30 minutes in a stable, windless and dark room, and it should be measured in the center of screen.

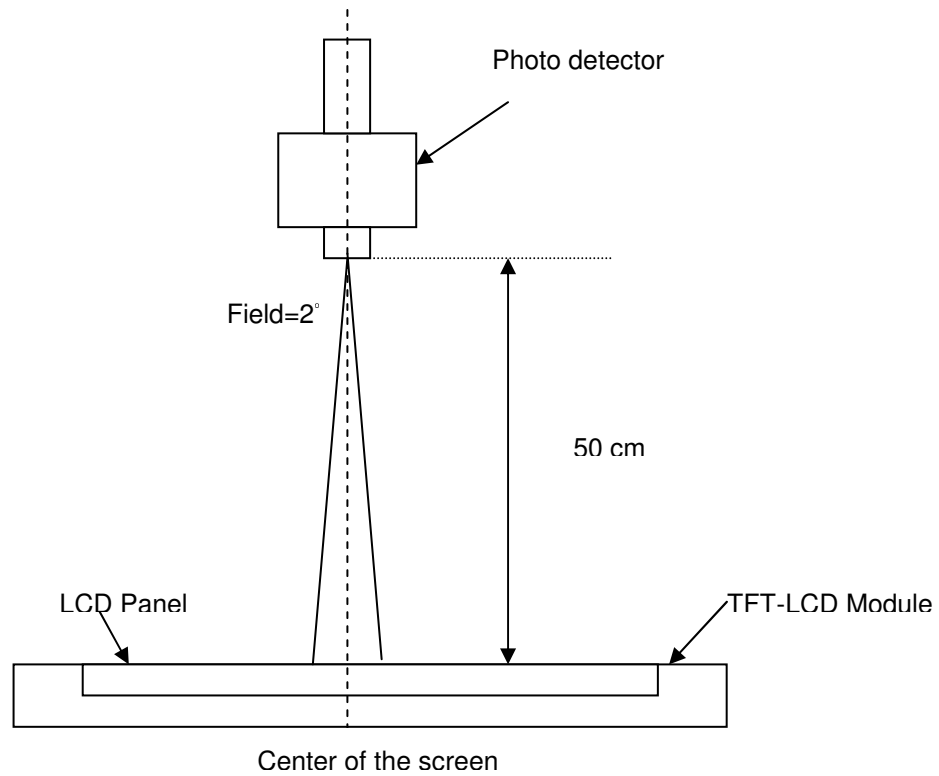

**Note 5 :** Definition of Average Luminance of White ( $Y_L$ ):

Measure the luminance of gray level 63 at 5 points ·  $Y_L = [L(1) + L(2) + L(3) + L(4) + L(5)] / 5$

$L(x)$  is corresponding to the luminance of the point X at Figure in Note (1).

**Note 6 :** Definition of contrast ratio:

Contrast ratio is calculated with the following formula.

$$\text{Contrast ratio (CR)} = \frac{\text{Brightness on the "White" state}}{\text{Brightness on the "Black" state}}$$

**Note 7 :** Definition of Cross Talk (CT)

$$CT = |Y_B - Y_A| / Y_A \times 100 (\%)$$

Where

$Y_A$  = Luminance of measured location without gray level 0 pattern ( $\text{cd}/\text{m}^2$ )

$Y_B$  = Luminance of measured location with gray level 0 pattern ( $\text{cd}/\text{m}^2$ )

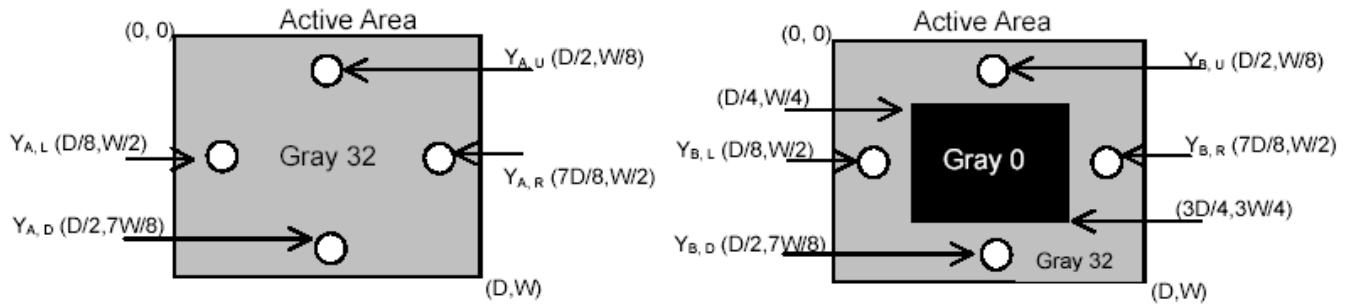

**Note 8:** Definition of response time:

The output signals of BM-7 or equivalent are measured when the input signals are changed from "Black" to "White" (falling time) and from "White" to "Black" (rising time), respectively. The response time interval between the 10% and 90% of amplitudes. Refer to figure as below.

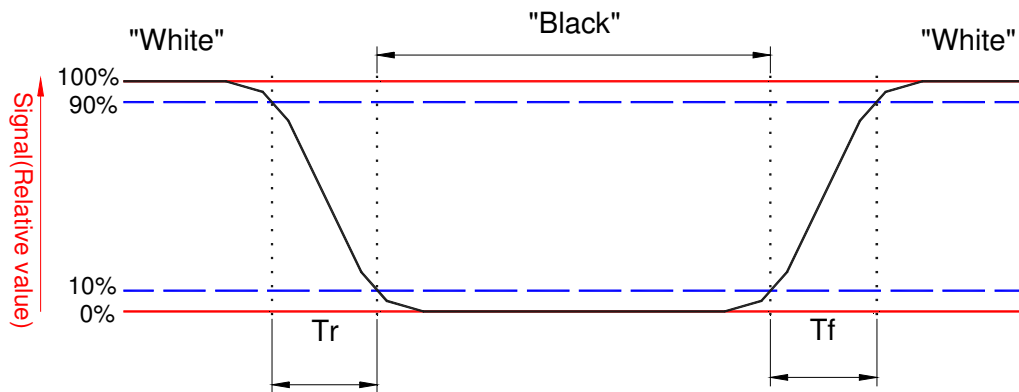

**Note 9.** Definition of viewing angle

Viewing angle is the measurement of contrast ratio  $\geq 10$ , at the screen center, over a  $180^\circ$  horizontal and  $180^\circ$  vertical range (off-normal viewing angles). The  $180^\circ$  viewing angle range is broken down as follows;  $90^\circ$  ( $\theta$ ) horizontal left and right and  $90^\circ$  ( $\phi$ ) vertical, high (up) and low (down). The measurement direction is typically perpendicular to the display surface with the screen rotated about its center to develop the desired measurement viewing angle.

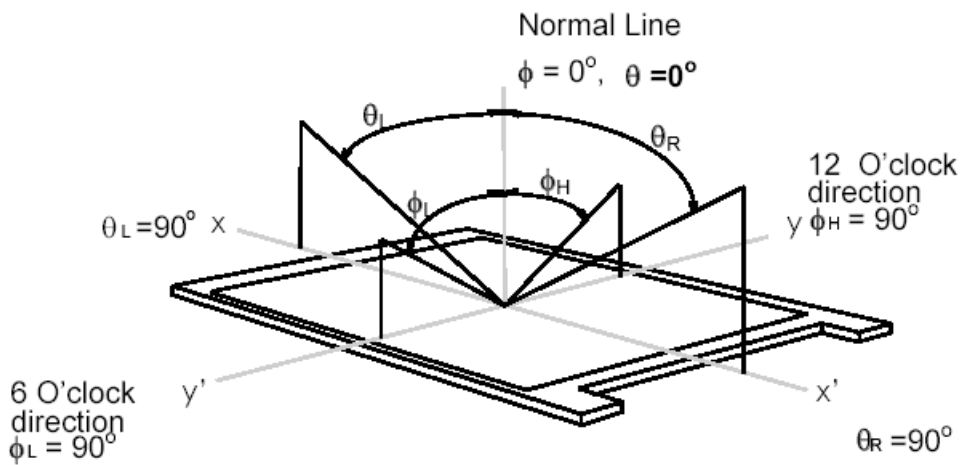

## 3. Functional Block Diagram

The following diagram shows the functional block of the 15.6 inches wide Color TFT/LCD 40 Pin one channel Module

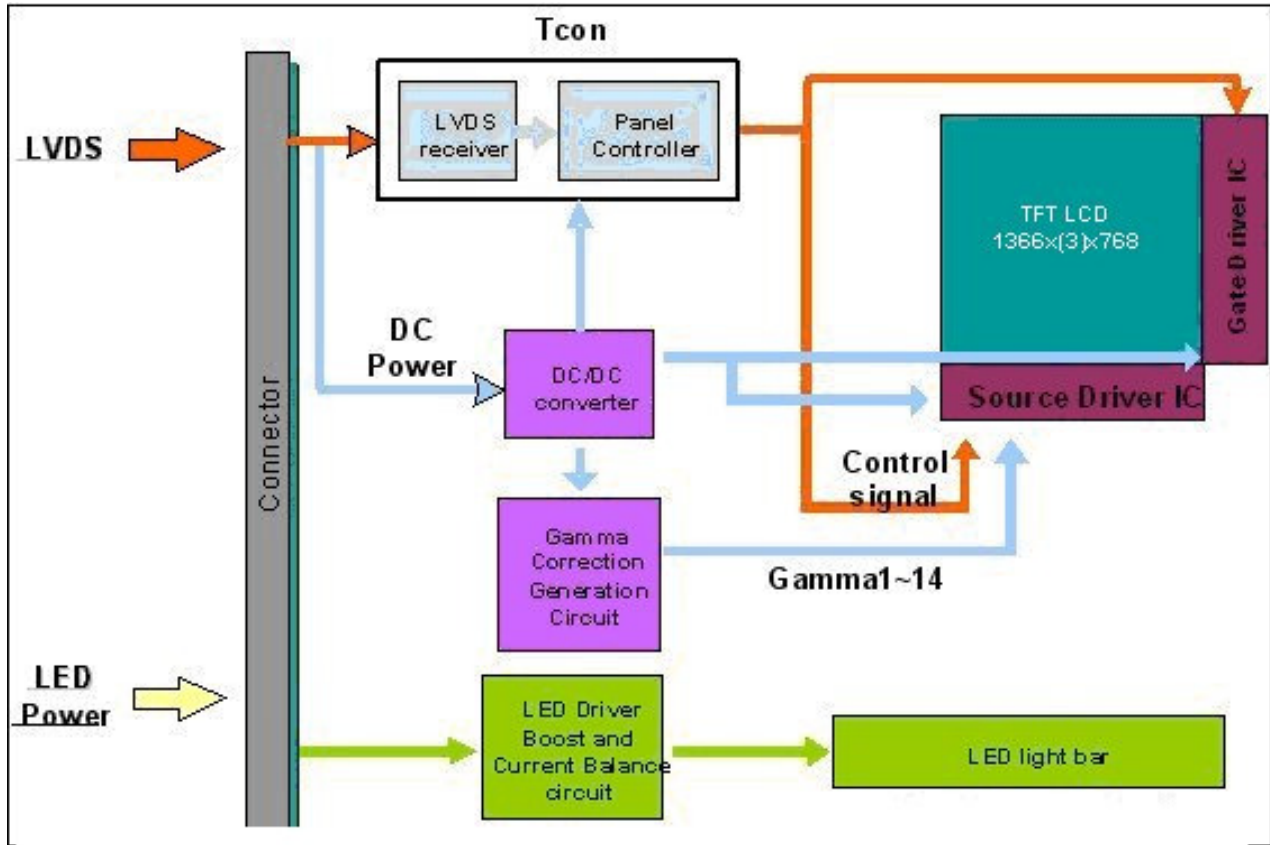

## 4. Absolute Maximum Ratings

An absolute maximum rating of the module is as following:

### 4.1 Absolute Ratings of TFT LCD Module

Item	Symbol	Min	Max	Unit	Conditions
Logic/LCD Drive Voltage	Vin	-0.3	+4.0	[Volt]	Note 1,2

### 4.2 Absolute Ratings of Environment

Item	Symbol	Min	Max	Unit	Conditions
Operating Temperature	TOP	0	+50	[°C]	Note 4
Operation Humidity	HOP	5	95	[%RH]	Note 4
Storage Temperature	TST	-20	+60	[°C]	Note 4
Storage Humidity	HST	5	95	[%RH]	Note 4

Note 1: At Ta (25°C )

Note 2: Permanent damage to the device may occur if exceed maximum values

Note 3: LED specification refer to section 5.2

Note 4: For quality performance, please refer to AUO IIS (Incoming Inspection Standard).

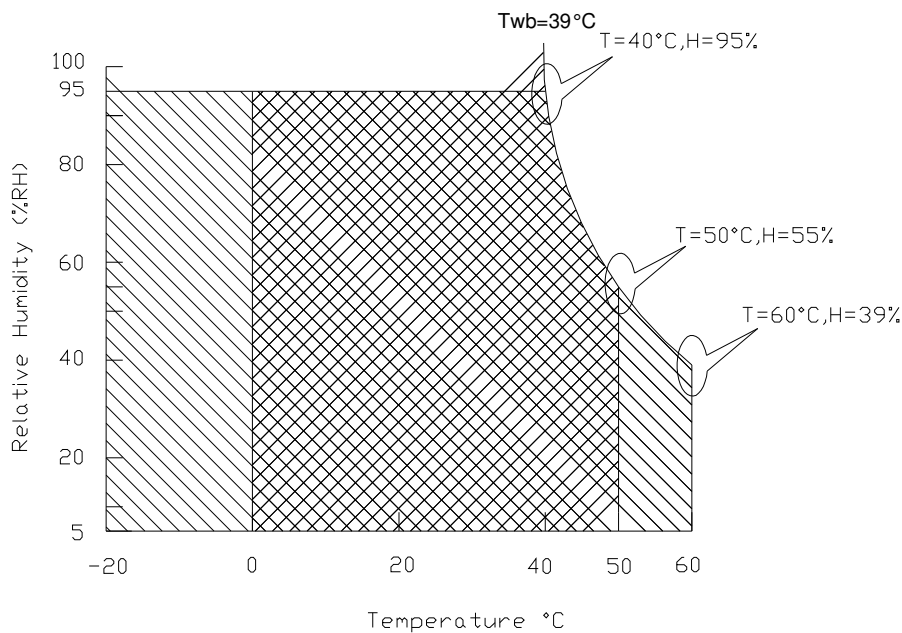

Operating Range 

Storage Range

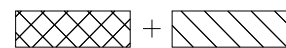

## 5. Electrical Characteristics

### 5.1 TFT LCD Module

#### 5.1.1 Power Specification

Input power specifications are as follows;

The power specification are measured under 25°C and frame frequency under 60Hz

Symble	Parameter	Min	Typ	Max	Units	Note
VDD	Logic/LCD Drive Voltage	3.0	3.3	3.6	[Volt]	
PDD	VDD Power	-	0.8	1.05	[Watt]	Note 1/2
IDD	IDD Current	-	303	400	[mA]	Note 1/2
IRush	Inrush Current	-	-	1500	[mA]	Note 3
VDDrp	Allowable Logic/LCD Drive Ripple Voltage	-	-	100	[mV] p-p	
DCR enable	Input logic high	3.0	-	5.5	[Volt]	
	Input logic low	-	-	0.8	[Volt]	
PWM signal	Input logic high	2.2	-	Vin	[Volt]	
	Input logic low	-	-	0.8	[Volt]	
B/L enable	Input logic high	2.2	-	5.5	[Volt]	
	Input logic low	-	-	0.8	[Volt]	

Note 1 : Maximum Measurement Condition : Black Pattern at 3.3V driving voltage. ( $P_{max}=V_{3.3} \times I_{black}$ )

Note 2 : Typical Measurement Condition: Mosaic Pattern

Note 3 : Measure Condition

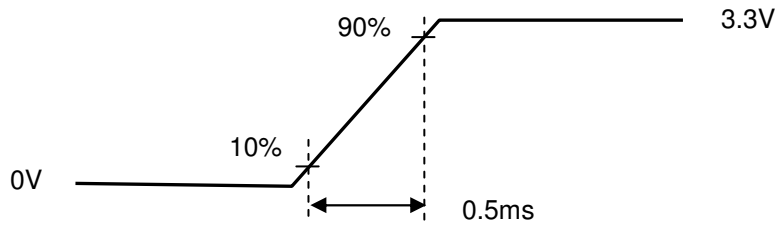
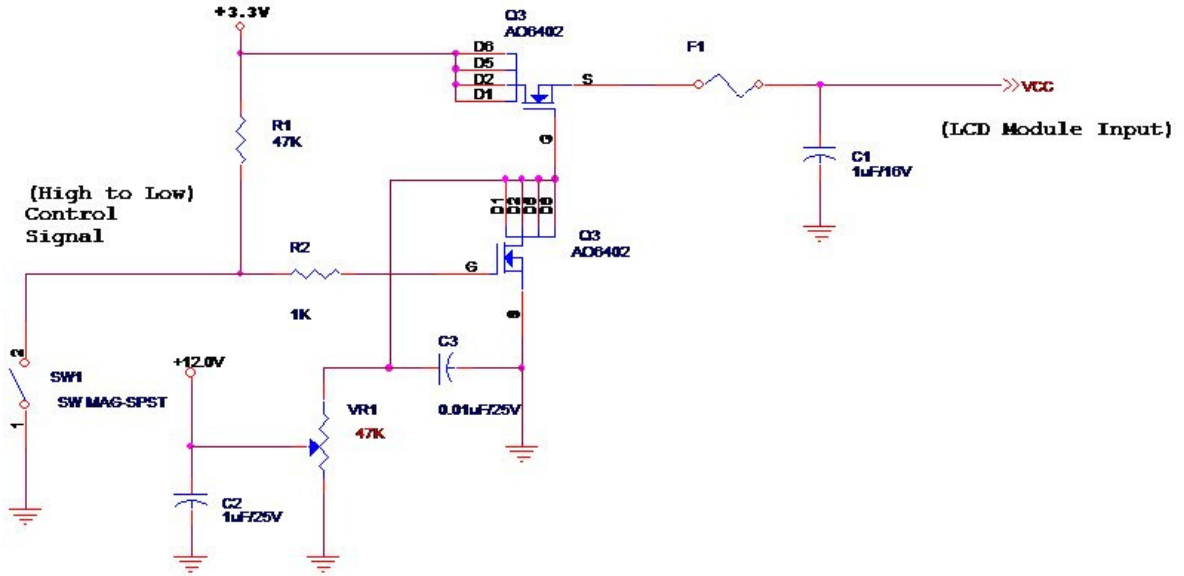

Vin rising time

## 5.1.2 Signal Electrical Characteristics

Input signals shall be low or High-impedance state when VDD is off.

Signal electrical characteristics are as follows;

Parameter	Condition	Min	Max	Unit
$V_{th}$	Differential Input High Threshold ( $V_{cm}=+1.2V$ )		100	[mV]
$V_{tl}$	Differential Input Low Threshold ( $V_{cm}=+1.2V$ )	-100	-	[mV]
$V_{ID}$	Differential Input Voltage	100	600	[mV]
$V_{cm}$	Differential Input Common Mode Voltage	1.125	1.375	[V]

Note: LVDS Signal Waveform

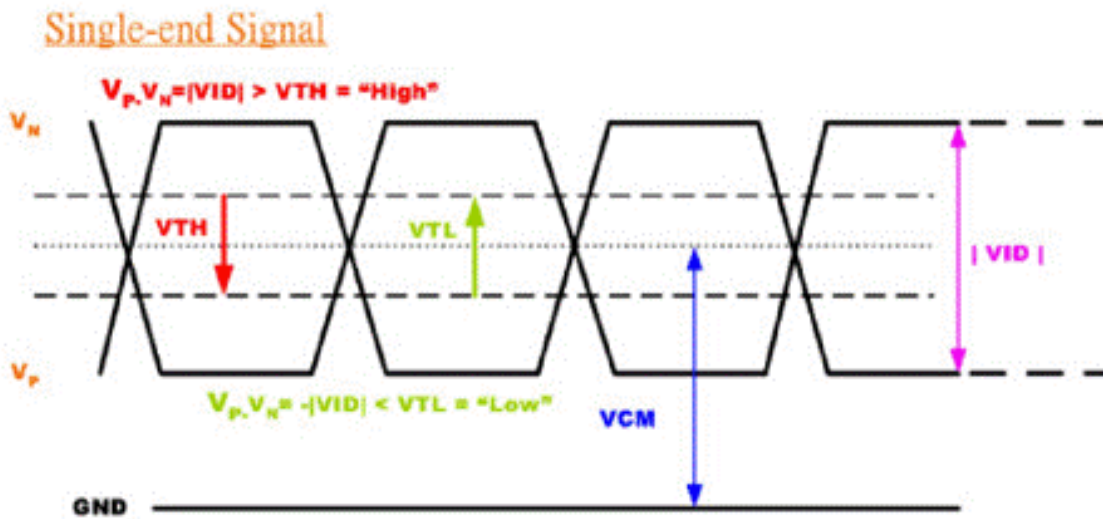

## 5.2 Backlight Unit

### 5.2.1 LED characteristics

Parameter	Symbol	Min	Typ	Max	Units	Condition
Backlight Power Consumption	PLED	-	3.65	4.2	[Watt]	(Ta=25°C), Note 1 Vin =12V
LED Life-Time	N/A	10,000	-	-	Hour	(Ta=25°C), Note 2 If=20 mA

**Note 1:** Calculator value for reference  $P_{LED} = V_F$  (Normal Distribution) \*  $I_F$  (Normal Distribution) / Efficiency

**Note 2:** The LED life-time define as the estimated time to 50% degradation of initial luminous.

### 5.2.2 Backlight input signal characteristics

Parameter	Symbol	Min	Typ	Max	Units	Remark
LED Power Supply	VLED	7	12	21	[Volt]	Define as Connector Interface (Ta=25°C)
LED Enable Input High Level	VLED_EN	2.1	3.3	3.5	[Volt]	
LED Enable Input Low Level		-	-	0.8	[Volt]	
PWM Logic Input High Level	VPWM_EN	2.1	3.3	3.5	[Volt]	
PWM Logic Input Low Level		-	-	0.8	[Volt]	
PWM Input Frequency	FPWM	100	-	20K	Hz	
PWM Duty Ratio	Duty	5	--	100	%	



## 6.2 The Input Data Format

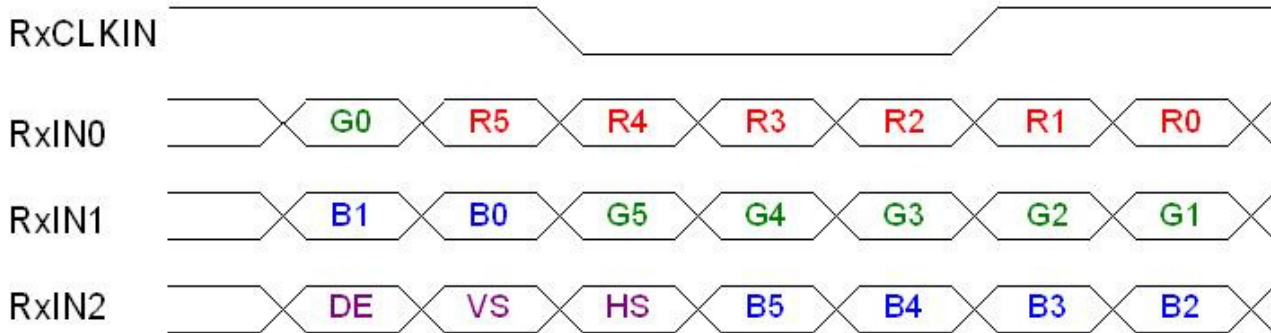

Signal Name	Description	
R5 R4 R3 R2 R1 R0	Red Data 5 (MSB) Red Data 4 Red Data 3 Red Data 2 Red Data 1 Red Data 0 (LSB)	Red-pixel Data Each red pixel's brightness data consists of these 6 bits pixel data.
G5 G4 G3 G2 G1 G0	Green Data 5 (MSB) Green Data 4 Green Data 3 Green Data 2 Green Data 1 Green Data 0 (LSB)	Green-pixel Data Each green pixel's brightness data consists of these 6 bits pixel data.
B5 B4 B3 B2 B1 B0	Blue Data 5 (MSB) Blue Data 4 Blue Data 3 Blue Data 2 Blue Data 1 Blue Data 0 (LSB)	Blue-pixel Data Each blue pixel's brightness data consists of these 6 bits pixel data.
RxCLKIN	Data Clock	The signal is used to strobe the pixel data and DE signals. All pixel data shall be valid at the falling edge when the DE signal is high.
DE	Display Timing	This signal is strobed at the falling edge of RxCLKIN. When the signal is high, the pixel data shall be valid to be displayed.
VS	Vertical Sync	The signal is synchronized to RxCLKIN .
HS	Horizontal Sync	The signal is synchronized to RxCLKIN .

Note: Output signals from any system shall be low or High-impedance state when VDD is off.

## 6.3 Integration Interface Requirement

### 6.3.1 Connector Description

Physical interface is described as for the connector on module.

These connectors are capable of accommodating the following signals and will be following components.

Connector Name / Designation	For Signal Connector
Manufacturer	IPEX or compatible
Type / Part Number	<b>IPEX 20455-040E-12A</b> or compatible
Mating Housing/Part Number	<b>IPEX 20453-040T-11</b> or compatible

### 6.3.2 Pin Assignment

LVDS is a differential signal technology for LCD interface and high speed data transfer device.

PIN#	Signal Name	Description
1	NC	No Connection (Reserve)
2	VDD	Power Supply +3.3V
3	VDD	Power Supply +3.3V
4	VEDID	EDID +3.3V Power
5	NC	No Connect (Reserve)
6	CLK_EDID	EDID Clock Input
7	DAT_EDID	EDID Data Input
8	RxOIN0-	-LVDS Differential Data INPUT(Odd R0-R5,G0)
9	RxOIN0+	+LVDS Differential Data INPUT(Odd R0-R5,G0)
10	VSS	Ground
11	RxOIN1-	-LVDS Differential Data INPUT(Odd G1-G5,B0-B1)
12	RxOIN1+	+LVDS Differential Data INPUT(Odd G1-G5,B0-B1)
13	VSS	Ground
14	RxOIN2-	-LVDS Differential Data INPUT(Odd B2-B5,HS,VS,DE)
15	RxOIN2+	+LVDS Differential Data INPUT(Odd B2-B5,HS,VS,DE)
16	VSS	Ground
17	RxOCKIN-	-LVDS Odd Differential Clock INPUT
18	RxOCKIN+	-LVDS Odd Differential Clock INPUT
19	VSS	Ground
20	NC	No connection
21	NC	No connection
22	NC	No connection

23	NC	No connection
24	NC	No connection
25	NC	No connection
26	NC	No connection
27	NC	No connection
28	NC	No connection
29	NC	No connection
30	NC	No connection
31	VLED_GND	LED Ground
32	VLED_GND	LED Ground
33	VLED_GND	LED Ground
34	NC	No Connection (Reserve)
35	VPWM_EN	PWM logic input level
36	VLED_EN	LED enable input level
37	DCR_EN	Dynamic Backlight Control (High Enable)
38	VLED	LED Power Supply
39	VLED	LED Power Supply
40	VLED	LED Power Supply

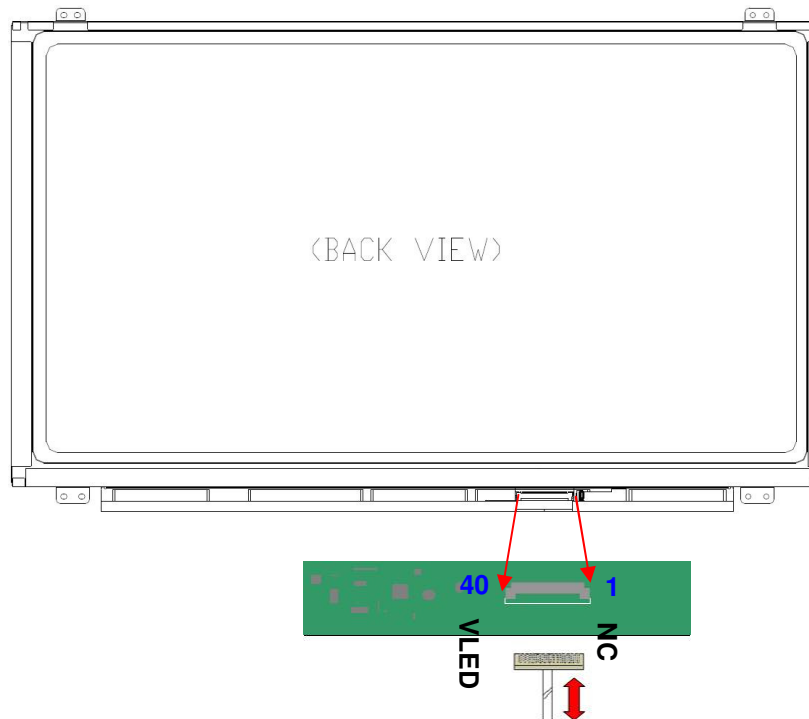

Note1: Input signals shall be low or High-impedance state when VDD is off.

## 6.4 Interface Timing

### 6.4.1 Timing Characteristics

Basically, interface timings should match the 1366x768 /60Hz manufacturing guide line timing.

Parameter	Symbol	Min.	Typ.	Max.	Unit	
Frame Rate	-	50	60	-	Hz	
Clock frequency	$1/ T_{\text{Clock}}$	65	70	80	MHz	
Vertical Section	Period	$T_V$	780	808	-	$T_{\text{Line}}$
	Active	$T_{VD}$	768			
	Blanking	$T_{VB}$	12	23	-	
Horizontal Section	Period	$T_H$	1400	1440	-	$T_{\text{Clock}}$
	Active	$T_{HD}$	1366			
	Blanking	$T_{HB}$	34	160	-	

Note : DE mode only

### 6.4.2 Timing diagram

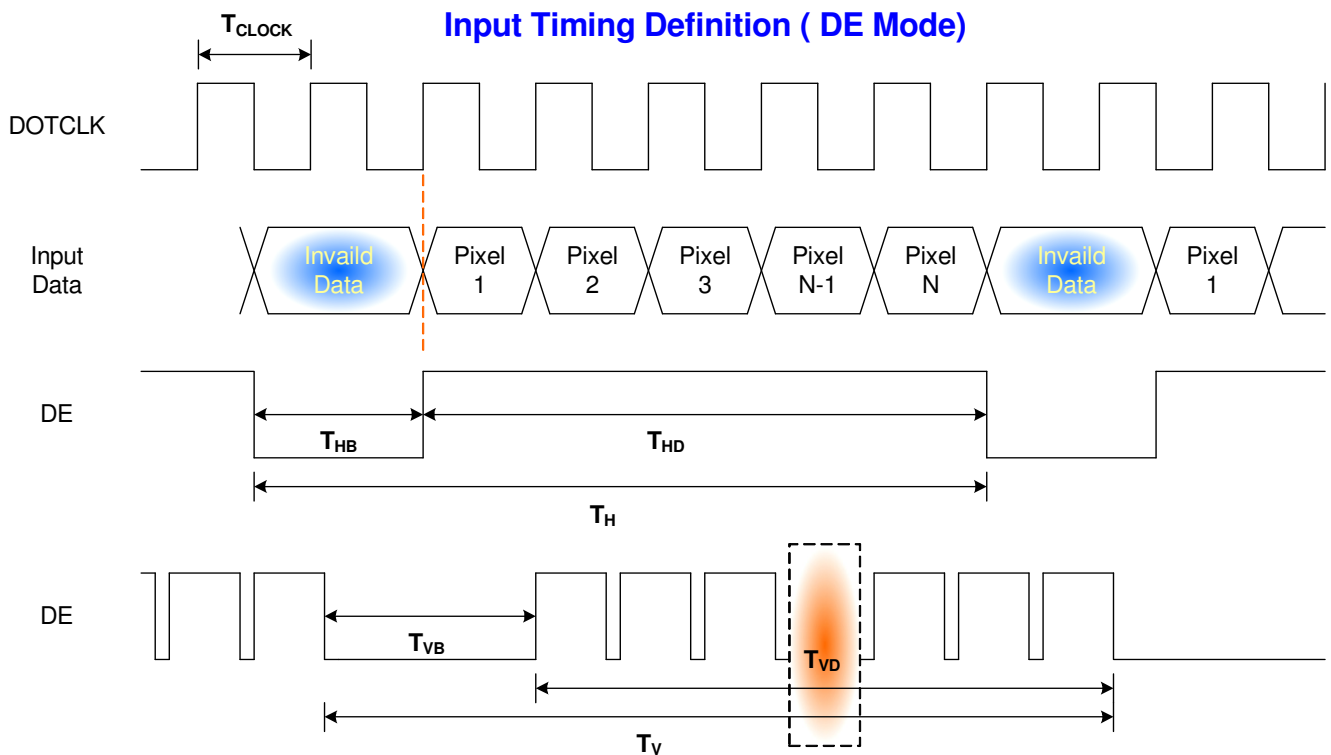

## 6.5 Power ON/OFF Sequence

Power on/off sequence is as follows. Interface signals and LED on/off sequence are also shown in the chart. Signals from any system shall be Hi-Z state or low level when VDD is off

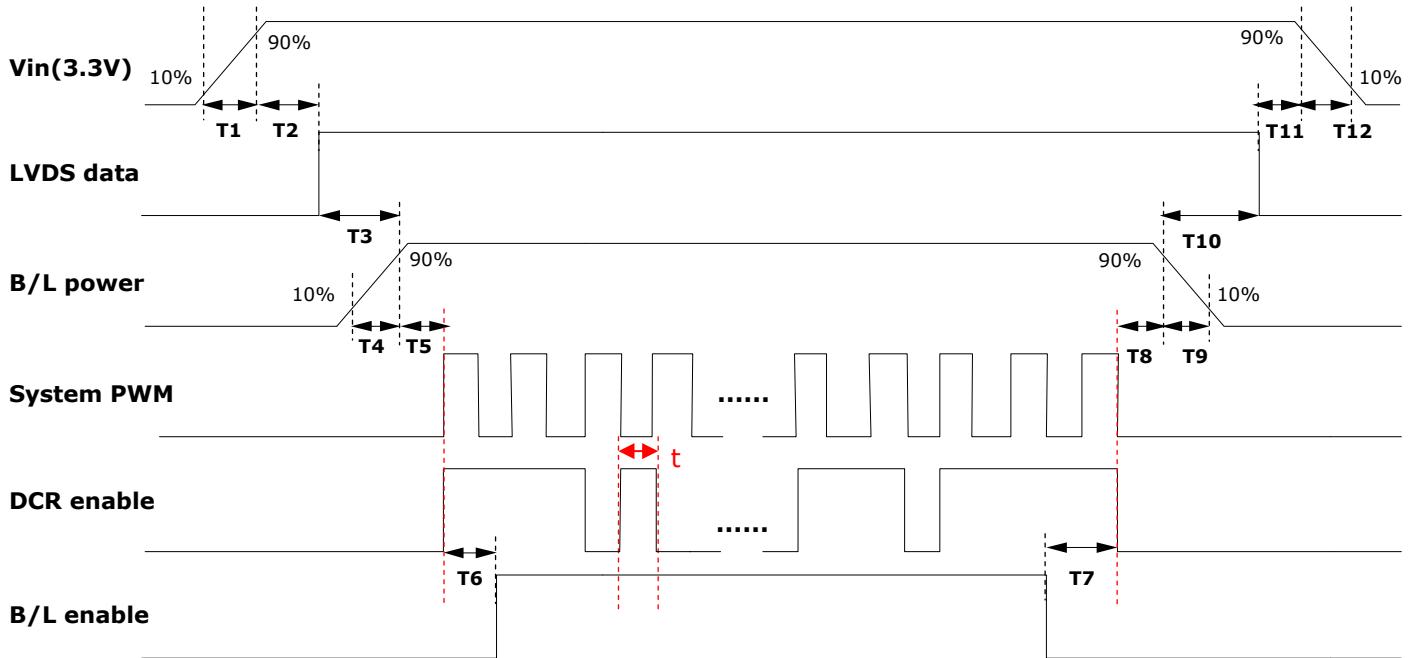

Parameter	Value (ms)		
	Min.	Typ.	Max.
T1	<b>0.5</b>	-	<b>10</b>
T2	<b>30</b>	<b>40</b>	<b>90</b>
T3	<b>200</b>	-	-
T4	<b>0.5</b>	-	<b>10</b>
T5	<b>10</b>	-	-
T6	<b>10</b>	-	-
T7	<b>0</b>	-	-
T8	<b>10</b>	-	-
T9	-	<b>10</b>	<b>30</b>
T10	<b>200</b>	-	-
T11	<b>0</b>	-	<b>50</b>
T12	-	<b>10</b>	<b>30</b>

Note: If T3, T5, T6 couldn't match above specifications, must request  $T3+T5+T6 > 200\text{ms}$  at least

## 7. Panel Reliability Test

### 7.1 Vibration Test

**Test Spec:**

- Test method: Non-Operation
- Acceleration: 1.5 G
- Frequency: 10 - 500Hz Random
- Sweep: 30 Minutes each Axis (X, Y, Z)

### 7.2 Shock Test

**Test Spec:**

- Test method: Non-Operation
- Acceleration: 220 G , Half sine wave
- Active time: 2 ms
- Pulse: X,Y,Z .one time for each side

### 7.3 Reliability Test

Items	Required Condition	Note
Temperature Humidity Bias	Ta= 40°C, 90%RH, 300h	
High Temperature Operation	Ta= 50°C, Dry, 300h	
Low Temperature Operation	Ta= 0°C, 300h	
High Temperature Storage	Ta= 60°C, 35%RH, 300h	
Low Temperature Storage	Ta= -20°C, 50%RH, 250h	
Thermal Shock Test	Ta=-20°C to 60°C, Duration at 30 min, 100 cycles	
ESD	Contact : ±8 KV Air : ±15 KV	Note 1

**Note1:** According to EN 61000-4-2 , ESD class B: Some performance degradation allowed. No data lost  
 . Self-recoverable. No hardware failures.

**Remark:** MTBF (Excluding the LED): 30,000 hours with a confidence level 90%



# Product Specification

AU OPTRONICS CORPORATION

## 8. Mechanical Characteristics

### 8.1 LCM Outline Dimension

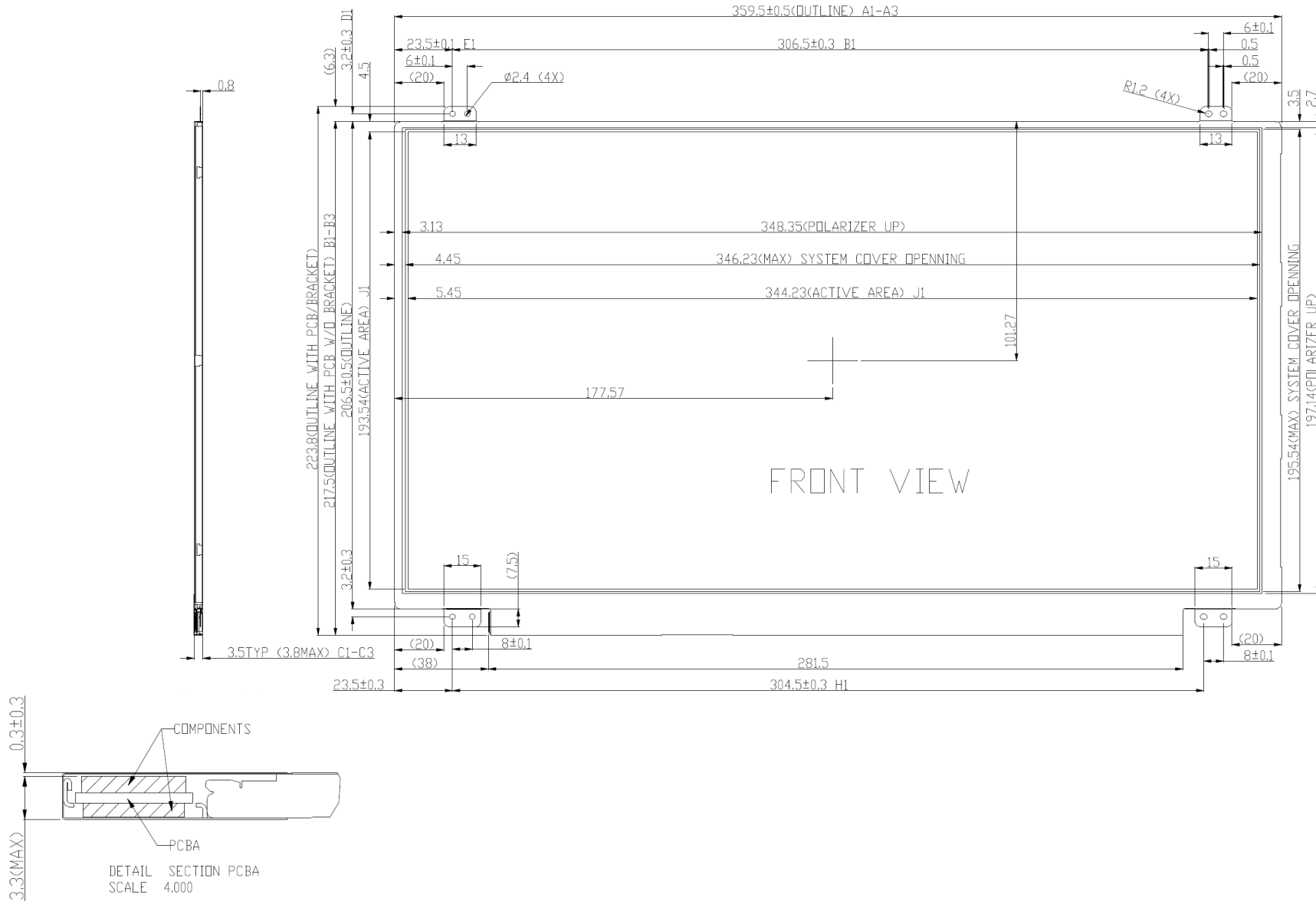



Note: Prevention IC damage, IC positions not allowed any overlap over these areas.

## 9. Shipping and Package

### 9.1 Shipping Label Format



### 9.2 Carton Package

The outline dimension of carton is 455 (L)mm x 380 (W)mm x 355 (H)mm



## 9.3 Shipping Package of Palletizing Sequence

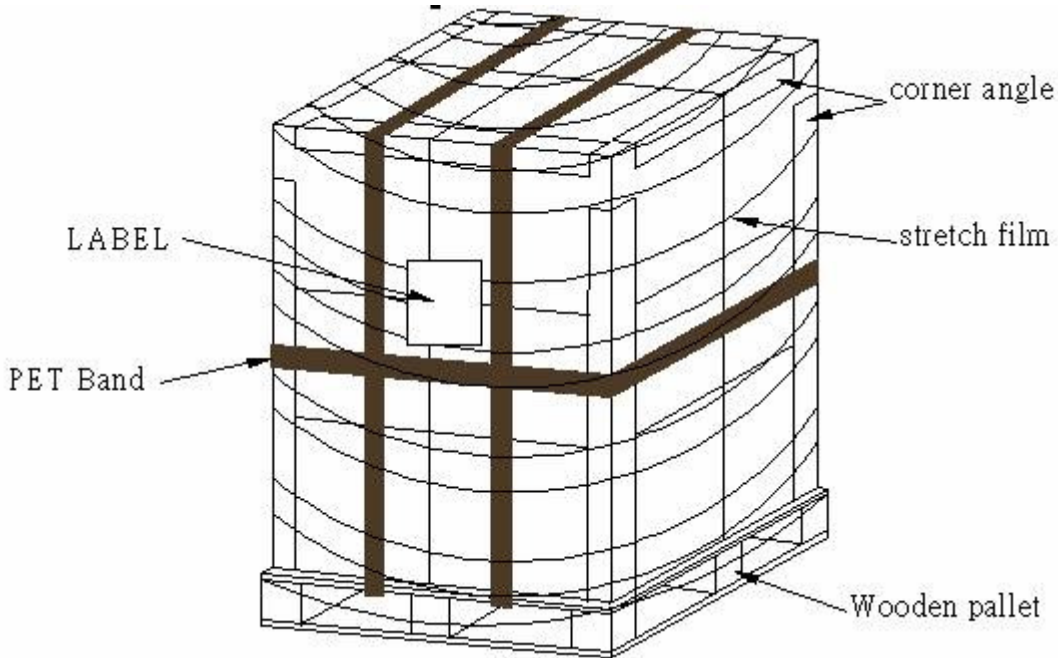

## 10. Appendix: EDID Description

Address	FUNCTION	Value	Value	Value	Note
HEX		HEX	BIN	DEC	
00	Header	00	00000000	0	
01		FF	11111111	255	
02		FF	11111111	255	
03		FF	11111111	255	
04		FF	11111111	255	
05		FF	11111111	255	
06		FF	11111111	255	
07		00	00000000	0	
08	EISA Manuf. Code LSB	06	00000110	6	
09	Compressed ASCII	AF	10101111	175	
0A	Product Code	EC	11101100	236	
0B	hex, LSB first	32	00110010	50	
0C	32-bit ser #	00	00000000	0	
0D		00	00000000	0	



# Product Specification

AU OPTRONICS CORPORATION

0E		00	00000000	0	
0F		00	00000000	0	
10	Week of manufacture	01	00000001	1	
11	Year of manufacture	13	00010011	19	
12	EDID Structure Ver.	01	00000001	1	
13	EDID revision #	03	00000011	3	
14	<b>Video input def. (digital I/P, non-TMDS, CRGB)</b>	80	10000000	128	
15	<b>Max H image size (rounded to cm)</b>	22	00100010	34	
16	<b>Max V image size (rounded to cm)</b>	13	00010011	19	
17	<b>Display Gamma (=gamma*100)-100</b>	78	01111000	120	
18	<b>Feature support (no DPMS, Active OFF, RGB, tmg Blk#1)</b>	0A	00001010	10	
19	Red/green low bits (Lower 2:2:2:2 bits)	6B	01101011	107	
1A	Blue/white low bits (Lower 2:2:2:2 bits)	2A	00101010	42	
1B	Red x (Upper 8 bits)	9D	10011101	157	
1C	Red y/ highER 8 bits	4C	01001100	76	
1D	Green x	42	01000010	66	
1E	Green y	84	10000100	132	
1F	Blue x	1C	00011100	28	
20	Blue y	0D	00001101	13	
21	White x	48	01001000	72	
22	White y	4C	01001100	76	
23	Established timing 1	00	00000000	0	
24	Established timing 2	00	00000000	0	
25	Established timing 3	00	00000000	0	
26	Standard timing #1	01	00000001	1	
27		01	00000001	1	
28	Standard timing #2	01	00000001	1	
29		01	00000001	1	
2A	Standard timing #3	01	00000001	1	
2B		01	00000001	1	
2C	Standard timing #4	01	00000001	1	
2D		01	00000001	1	
2E	Standard timing #5	01	00000001	1	
2F		01	00000001	1	
30	Standard timing #6	01	00000001	1	
31		01	00000001	1	
32	Standard timing #7	01	00000001	1	
33		01	00000001	1	



# Product Specification

AU OPTRONICS CORPORATION

34	Standard timing #8	01	00000001	1	
35		01	00000001	1	
36	Pixel Clock/10000 LSB	58	01011000	88	
37	Pixel Clock/10000 USB	1B	00011011	27	
38	Horz active Lower 8bits	56	01010110	86	
39	Horz blanking Lower 8bits	66	01100110	102	
3A	HorzAct:HorzBlnk Upper 4:4 bits	50	01010000	80	
3B	Vertical Active Lower 8bits	00	00000000	0	
3C	Vertical Blanking Lower 8bits	1A	00011010	26	
3D	Vert Act : Vertical Blanking (upper 4:4 bit)	30	00110000	48	
3E	HorzSync. Offset	30	00110000	48	
3F	HorzSync.Width	20	00100000	32	
40	VertSync.Offset : VertSync.Width	36	00110110	54	
41	Horz&Vert Sync Offset/Width Upper 2bits	00	00000000	0	
42	Horizontal Image Size Lower 8bits	58	01011000	88	
43	Vertical Image Size Lower 8bits	C1	11000001	193	
44	Horizontal & Vertical Image Size (upper 4:4 bits)	10	00010000	16	
45	Horizontal Border (zero for internal LCD)	00	00000000	0	
46	Vertical Border (zero for internal LCD)	00	00000000	0	
47	Signal (non-intr, norm, no stero, sep sync, neg pol)	18	00011000	24	
48	Detailed timing/monitor	00	00000000	0	
49	descriptor #2	00	00000000	0	
4A		00	00000000	0	
4B		0F	00001111	15	
4C		00	00000000	0	
4D		00	00000000	0	
4E		00	00000000	0	
4F		00	00000000	0	
50		00	00000000	0	
51		00	00000000	0	
52		00	00000000	0	
53		00	00000000	0	
54		00	00000000	0	
55		00	00000000	0	
56		00	00000000	0	
57		00	00000000	0	
58		00	00000000	0	
59		20	00100000	32	



# Product Specification

AU OPTRONICS CORPORATION

5A	Detailed timing/monitor	00	00000000	0	
5B	descriptor #3	00	00000000	0	
5C		00	00000000	0	
5D		FE	11111110	254	
5E		00	00000000	0	
5F	Manufacture	41	01000001	65	A
60	Manufacture	55	01010101	85	U
61	Manufacture	4F	01001111	79	O
62		0A	00001010	10	
63		20	00100000	32	
64		20	00100000	32	
65		20	00100000	32	
66		20	00100000	32	
67		20	00100000	32	
68		20	00100000	32	
69		20	00100000	32	
6A		20	00100000	32	
6B		20	00100000	32	
6C	Detailed timing/monitor	00	00000000	0	
6D	descriptor #4	00	00000000	0	
6E		00	00000000	0	
6F		FE	11111110	254	
70		00	00000000	0	
71	Manufacture P/N	42	01000010	66	B
72	Manufacture P/N	31	00110001	49	1
73	Manufacture P/N	35	00110101	53	5
74	Manufacture P/N	36	00110110	54	6
75	Manufacture P/N	58	01011000	88	X
76	Manufacture P/N	57	01010111	87	W
77	Manufacture P/N	30	00110000	48	0
78	Manufacture P/N	33	00110011	51	3
79	Manufacture P/N	20	00100000	32	
7A	Manufacture P/N	56	01010110	86	V
7B	Manufacture P/N	32	00110010	50	2
7C		20	00100000	32	
7D		0A	00001010	10	
7E	Extension Flag	00	00000000	0	
7F	Checksum	47	01000111	71	