

mass integrated

global part distribution • product lifecycle partner
excess inventory management • value-ad service provider



Data sheet provided by Mass Integrated

massintegrated.com • displayalliance.com

Please call +1.978.465.6190
Email: sales@massintegrated.com



ISO 9001: 2008

Mass Integrated complies with all DMCA takedown notices. Please send a formal DMCA Takedown Notice to Mass Integrated Systems, Inc. • 18 Henry Graf Jr. Road, Unit 1 • Newburyport, MA 01950.

INNOLUX DISPLAY CORPORATION

BT140GW01 V.0 LCD MODULE SPECIFICATION

- () Preliminary Specification
(●) Final Specification

Customer	Checked & Approved by

Approved by	Checked by	Prepared by
MKT	PD	PM
		Monica Huang

Date: 2009/06/16

Innolux Display Corporation

No.160 Kesyue Rd., Chu-Nan Site, Hsinchu Science Park,

Chu-Nan 350, Miao-Li County, Taiwan

Tel: 886-37-586000

Fax: 886-37-586060

版權屬於群創所有，禁止任何未經授權的使用

The copyright belongs to INNOLUX. Any unauthorized use is prohibited.

Contents:	Page
1. General Specifications	2
2. Electrical Specifications	
2-1 Pin Assignment	3
2-2 Absolute Maximum Ratings	5
2-3 Electrical Characteristics	6
3. Optical Specifications	12
4. Reliability Test Items	16
5. Safety	17
6. Display Quality	17
7. Handling Precaution	17
8. Label Definition	18
9. Packing Form	20
10. Mechanical Drawings	21
Appendix	23

版權屬於群創所有，禁止任何未經授權的使用

1. General Specifications

NO.	Item	Specification	Unit
1	Display resolution (pixel)	1366(H) X 768(V), HD resolution	
2	Active area	309.40(H) X 173.95(V)	mm
3	Screen size	14.0 inches diagonal	Inches
4	Pixel pitch	0.2265(H) X 0.2265(V)	mm
5	Color configuration	Stripe	
6	Overall dimension	324(W) X 192.5(H) X 5.2(D) (max)	mm
7	Weight	350Max.	Grams
8	Surface treatment	Glare, 3H	
9	Input color signal	6 bit LVDS	
10	Display colors	262K (6 bit)	
11	Optimum viewing direction	6 o'clock	
12	Backlight	W-LED	
13	RoHS	RoHS compliance	

版權屬於群創所有，禁止任何未經授權的使用

2. Electrical Specifications

2-1 Pin Assignment

a. Panel connector

Connector Part No.: 20455-040-12 (I-PEX) or equivalent

User's connector Part No: 20453-040T-12 (I-PEX) or equivalent

Pin No	Symbol	Description	Remark
1	DIAG_LOOP	Plug detection pin	
2	V _{CC}	Power Supply (+3.3V)	
3	V _{CC}	Power Supply (+3.3V)	
4	V _{EDID}	DDC Power +3.3V	
5	BIST	BIST function enable (+3.3V)	
6	CLK _{EDID}	DDC Clock	
7	DATA _{EDID}	DDC Data	
8	Rxin0-	Differential Data Input	R0~R5,G0
9	Rxin0+	Differential Data Input	
10	GND	Ground	
11	Rxin1-	Differential Data Input	G1~G5,B0,B1
12	Rxin1+	Differential Data Input	
13	GND	Ground	
14	Rxin2-	Differential Data Input	B2~B5,DE,Hsync,Vsync
15	Rxin2+	Differential Data Input	
16	GND	Ground	
17	CLK-	Differential Clock Input	
18	CLK+	Differential Clock Input	
19	NC	No connection (Reserve)	
20	NC	No connection (Reserve)	
21	NC	No connection (Reserve)	
22	NC	No connection (Reserve)	
23	NC	No connection (Reserve)	
24	NC	No connection (Reserve)	
25	NC	No connection (Reserve)	
26	NC	No connection (Reserve)	
27	NC	No connection (Reserve)	
28	NC	No connection (Reserve)	
29	NC	No connection (Reserve)	
30	NC	No connection (Reserve)	
31	LED_GND	LED Ground	
32	LED_GND	LED Ground	
33	LED_GND	LED Ground	
34	DIAG_LOOP	Plug detection pin	
35	LED_PWM	PWM dimming signal input	
36	LED_EN	LED enable pin (3.3V)	
37	NC	No connection (Reserve)	
38	V_LED	LED power supply 7.5V~21V	
39	V_LED	LED power supply 7.5V~21V	
40	V_LED	LED power supply 7.5V~21V	

b. General Block Diagram

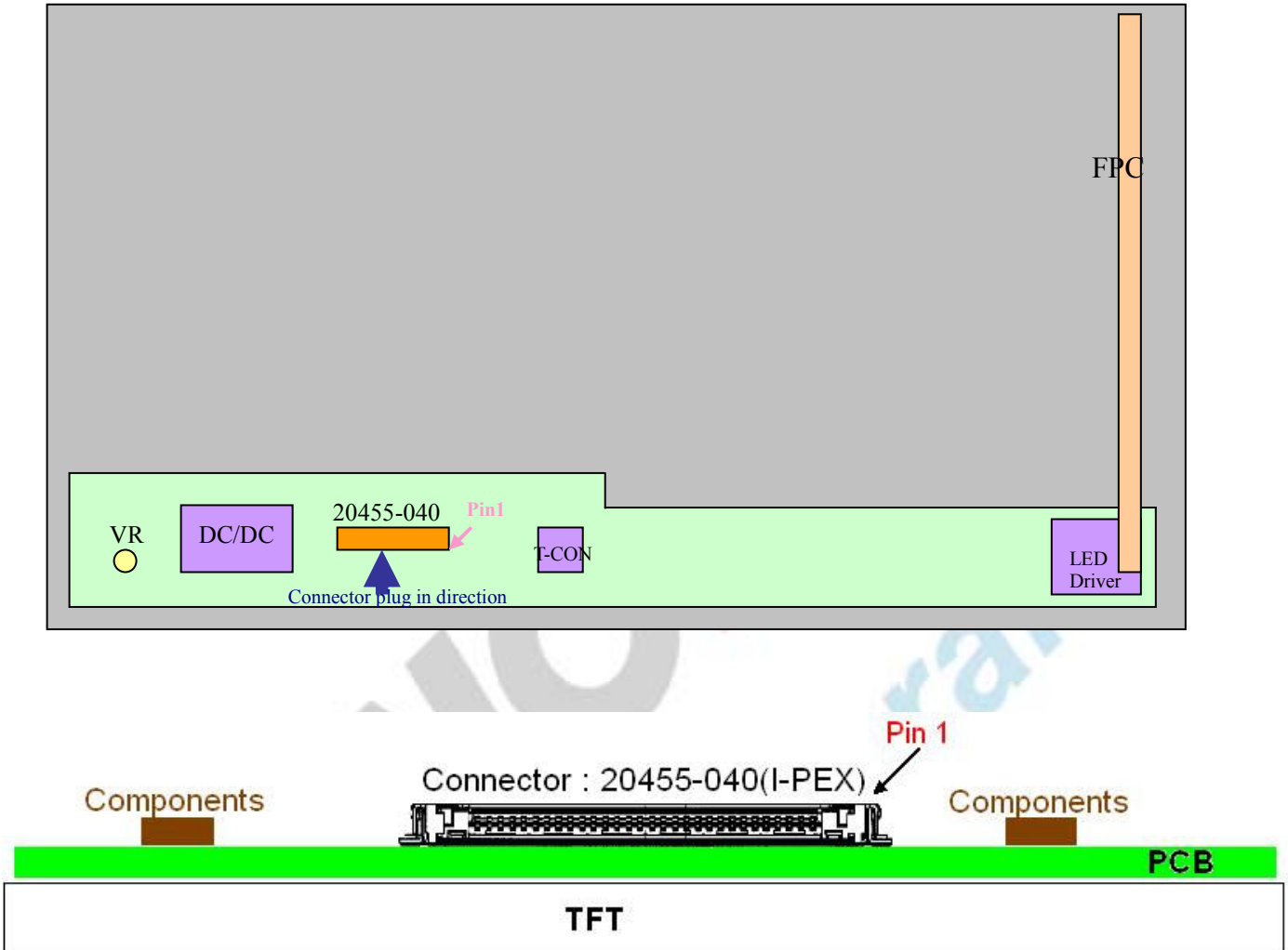

版權屬於群創所有，禁止任何未經授權的使用

2-2. Absolute Maximum Ratings

Parameter	Symbol	Values		Unit	Remark
		Min.	Max.		
Power input voltage	V_{CC}	- 0.3	4.0	V	At 25°C
Signal input voltage	V_{IN}	- 0.3	4.0	V	At 25°C
Operating temperature	T_{OP}	0	50	°C	Note 1
Storage temperature	T_{ST}	- 20	60	°C	Note 2
Re-screw		-	5	Times	
Assured torque at side mount		-	2	kgf.cm	

Note 1: The relative humidity must not exceed 90% non-condensing at temperatures of 40°C or less. At temperatures greater than 40°C, the wet bulb temperature must not exceed 39°C.

Note 2: The unit should not be exposed to corrosive chemicals.

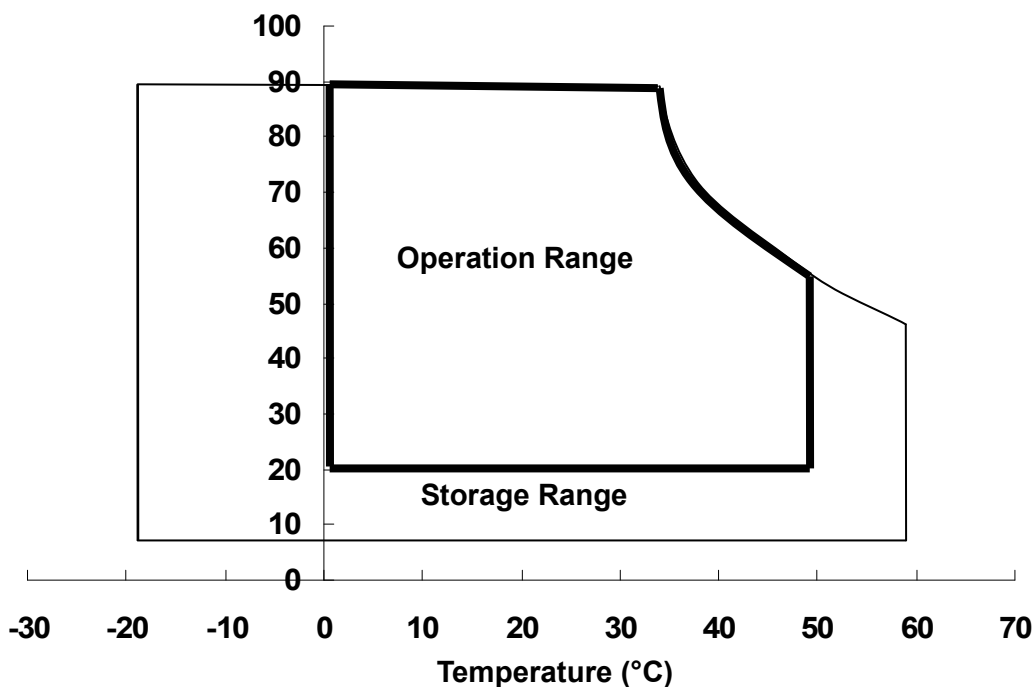
Relative Humidity (%RH)

版權屬於群創所有，禁止任何未經授權的使用

2-3. Electrical Characteristics

a. Typical operating conditions

Item	Symbol	Min.	Typ.	Max.	Unit	Remark
Power input voltage	V_{CC}	3	3.3	3.6	V	
Permissive power input ripple	V_{RF}	-	-	0.1	V	
Power input current	I_{CC}	-	300	330	mA	Note 1
Power consumption	P_C	-		1	Watts	Note 1
LVDS interface	Differential input high threshold voltage	V_{LVTH}	-	+100	mV	LVDS interface
	Differential input low threshold voltage	V_{LVTL}	-100	-	mV	
	Common input voltage	V_{LVC}	1.0	1.2	V	
	Terminating resistor	R_T	90	100	ohm	
Rush current	I_{Rush}	-	-	1.5	A	Note 3
LED rush current	$I_{LED-Rush}$	-	-	3.0	A	Note 4

Note 1: The specified input current and power consumption are under the $V_{CC} = 3.3\text{ V}$, 25°C , $f_V = 60\text{ Hz}$ (frame frequency) condition whereas black pattern is displayed.

Note 2: LVDS waveform diagram

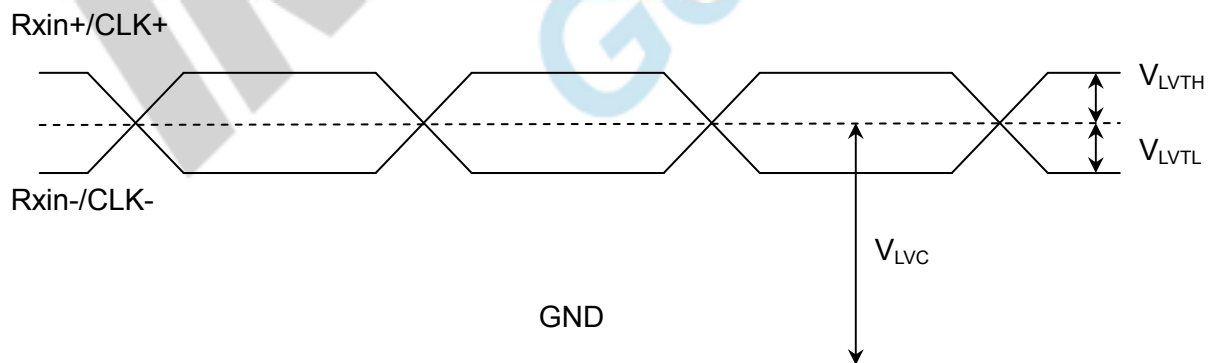

版權屬於群創所有，禁止任何未經授權的使用

Note 3: Test condition

(1) Pattern: Black pattern

(2) $V_{CC} = 3.3\text{ V}$, V_{CC} rising time = $470\ \mu\text{s} \pm 10\%$

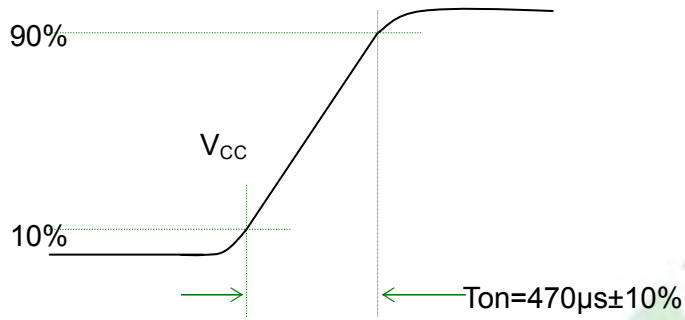

(3) Test circuit

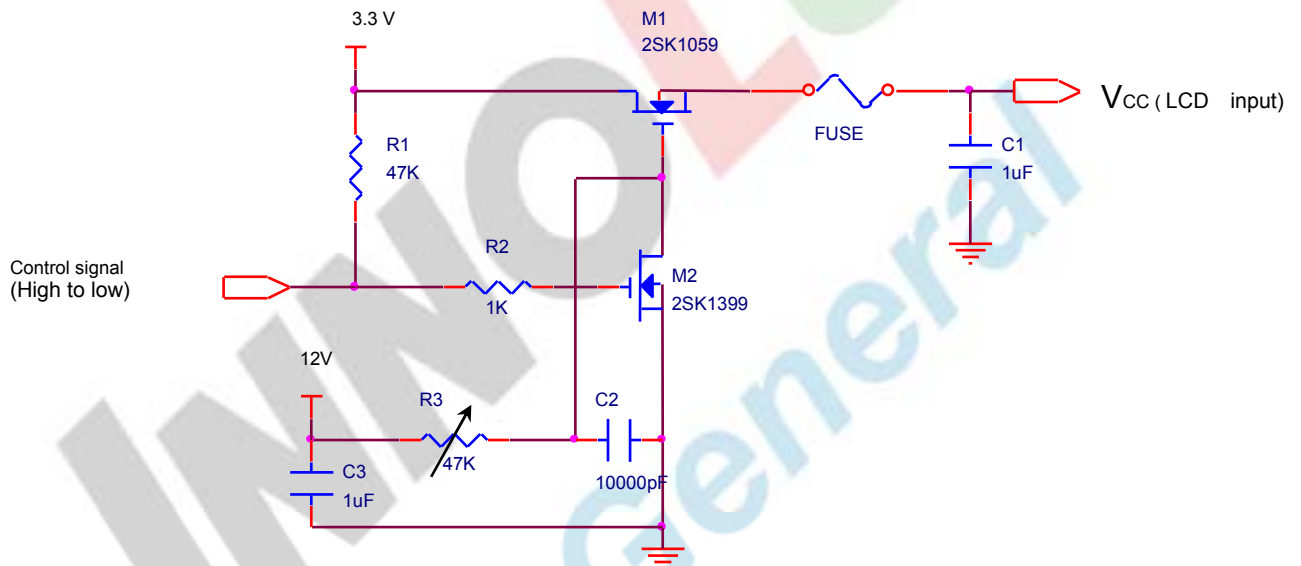

版權屬於群創所有，禁止任何未經授權的使用

Note 4: Test condition

(1) Pattern: LED duty 100%

(2) $V_{LED} = 12.0V$, V_{LED} rising time = $470 \mu s \pm 10\%$

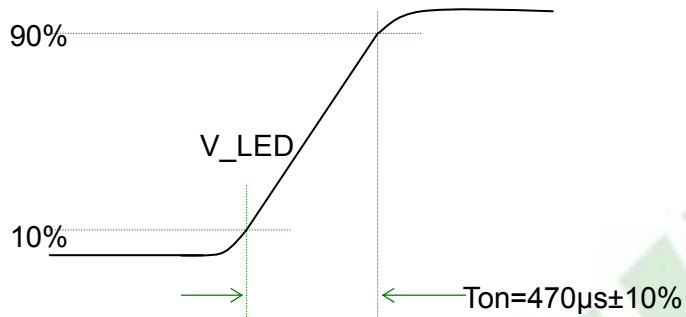

(3) Test circuit

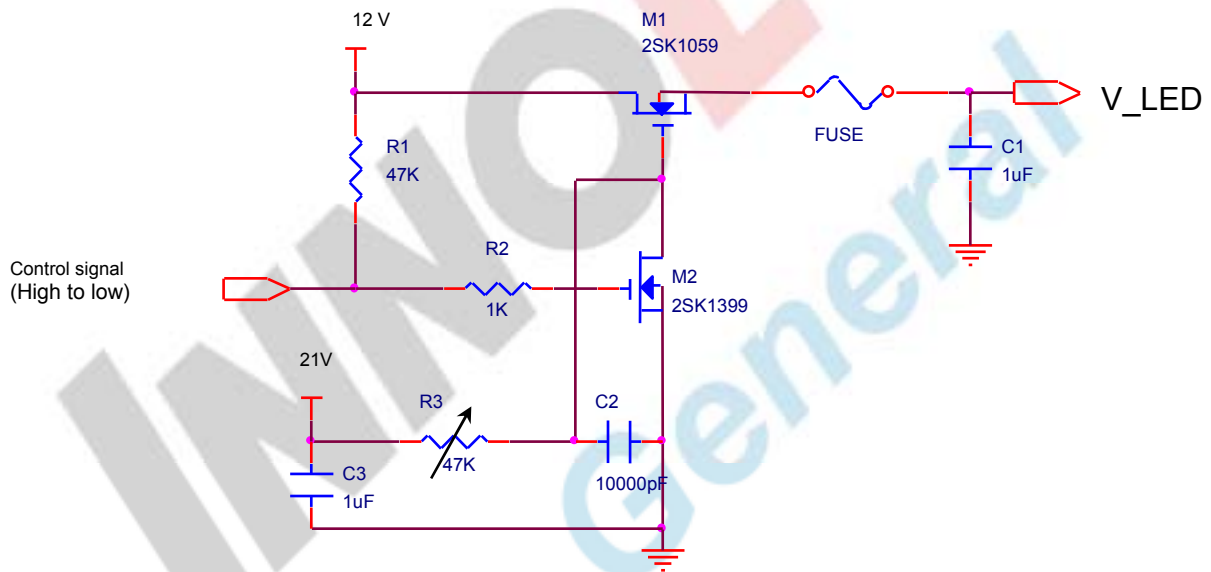

版權屬於群創所有，禁止任何未經授權的使用

b. Power sequence

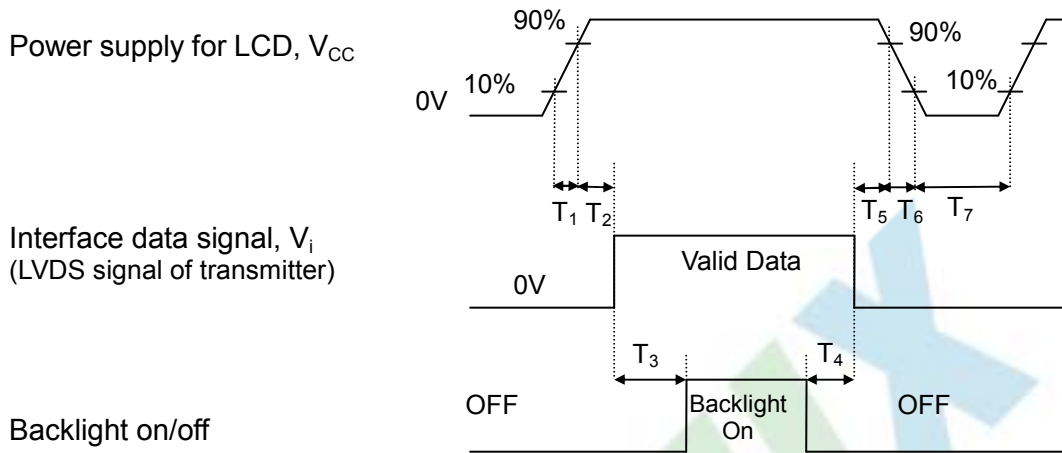

Power sequence timing table

Parameter	Value			Units
	Min.	Typ.	Max.	
T_1	0.5	-	10	ms
T_2	0	-	50	ms
T_3	200	-	-	ms
T_4	200	-	-	ms
T_5	0	-	50	ms
T_6	0	-	10	ms
T_7	400	-	-	ms

版權屬於群創所有，禁止任何未經授權的使用

c. Display color vs. input data signals

Signal Name	Description	Remark
R5	Red Data 5 (MSB)	Red-pixel data. Each red pixel's brightness data consists of these 6 bits pixel data.
R4	Red Data 4	
R3	Red Data 3	
R2	Red Data 2	
R1	Red Data 1	
R0	Red Data 0 (LSB)	
	Red-pixel Data	
G5	Green Data 5 (MSB)	Green-pixel data. Each green pixel's brightness data consists of these 6 bits pixel data.
G4	Green Data 4	
G3	Green Data 3	
G2	Green Data 2	
G1	Green Data 1	
G0	Green Data 0 (LSB)	
	Green-pixel Data	
B5	Blue Data 5 (MSB)	Blue-pixel data. Each blue pixel's brightness data consists of these 6 bits pixel data.
B4	Blue Data 4	
B3	Blue Data 3	
B2	Blue Data 2	
B1	Blue Data 1	
B0	Blue Data 0 (LSB)	
	Blue-pixel Data	

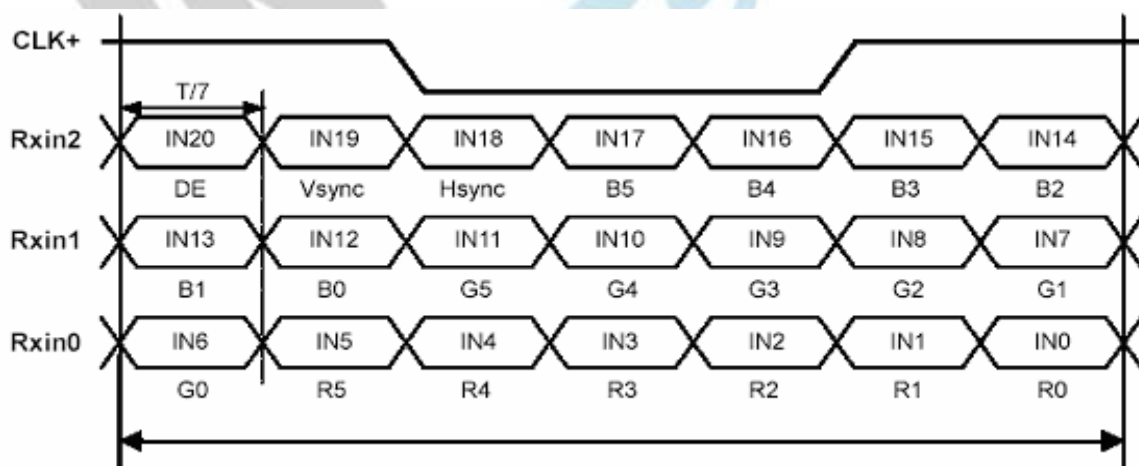

Signal for 1 DCLK cycle (t_{CLK})

版權屬於群創所有，禁止任何未經授權的使用

d. Input signal timing

Timing table

Description	Symbol	Min	Typ	Max	Unit
Frame rate	--	50	60	--	Hz
Clock freq.	$1/t_{CLK}$	65	75	85	MHz
Line cycle time	t_H	1400	1560	1800	t_{CLK}
Line width-active	t_{Hd}	1366	1366	1366	t_{CLK}
Frame cycle time	t_v	780	806	900	t_H
V width-active	t_{vd}	768	768	768	t_H

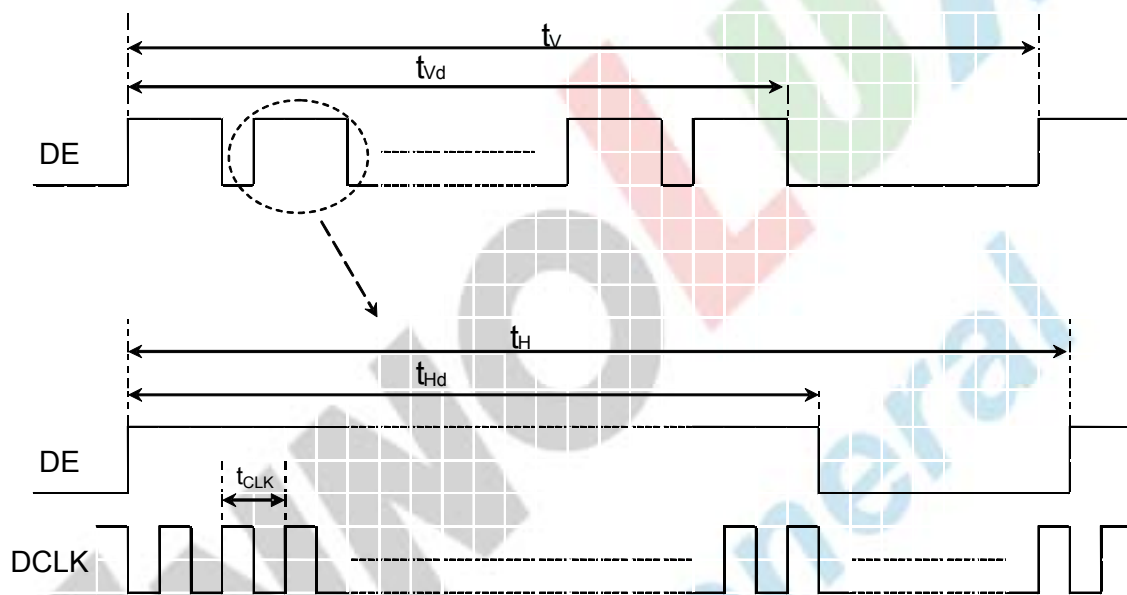

e. Display position

D(1, 1)	D(2, 1)	D(683, 1)	D(1365, 1)	D(1366, 1)
D(1, 2)	D(2, 2)	D(683, 2)	D(1365, 2)	D(1366, 2)
⋮		⋮	⋮	⋮
D(1, 384)	D(2, 384)	D(683, 384)	D(1365, 384)	D(1366, 384)
⋮		⋮	⋮	⋮
D(1, 767)	D(2, 767)	D(683, 767)	D(1365, 767)	D(1366, 767)
D(1, 768)	D(2, 768)	D(683, 768)	D(1365, 768)	D(1366, 768)

版權屬於群創所有，禁止任何未經授權的使用

f. Backlight driving conditions

Parameter	Symbol	Min.	Typ.	Max.	Unit	Remark
LED Forward Voltage	V_F	2.8	3.2	3.4	V_{rms}	T = 25°C
LED Forward Current	I_F		20		mA_{rms}	T = 25°C
Power consumption	P_{LED}		3.6	3.8	W	T = 25°C
Input PWM frequency	F_{PWM}	180		2000	Hz	T = 25°C
Duty ratio	-	5		100	%	Note 1
LED life time	-	15,000			Hr	T = 25°C , Note 2

Note 1: PWM duty ratio linearity guarantees 10~100%

Note 2: LED life time definition is Brightness decrease to 50% of initial or abnormal lighting.

g. Module function block

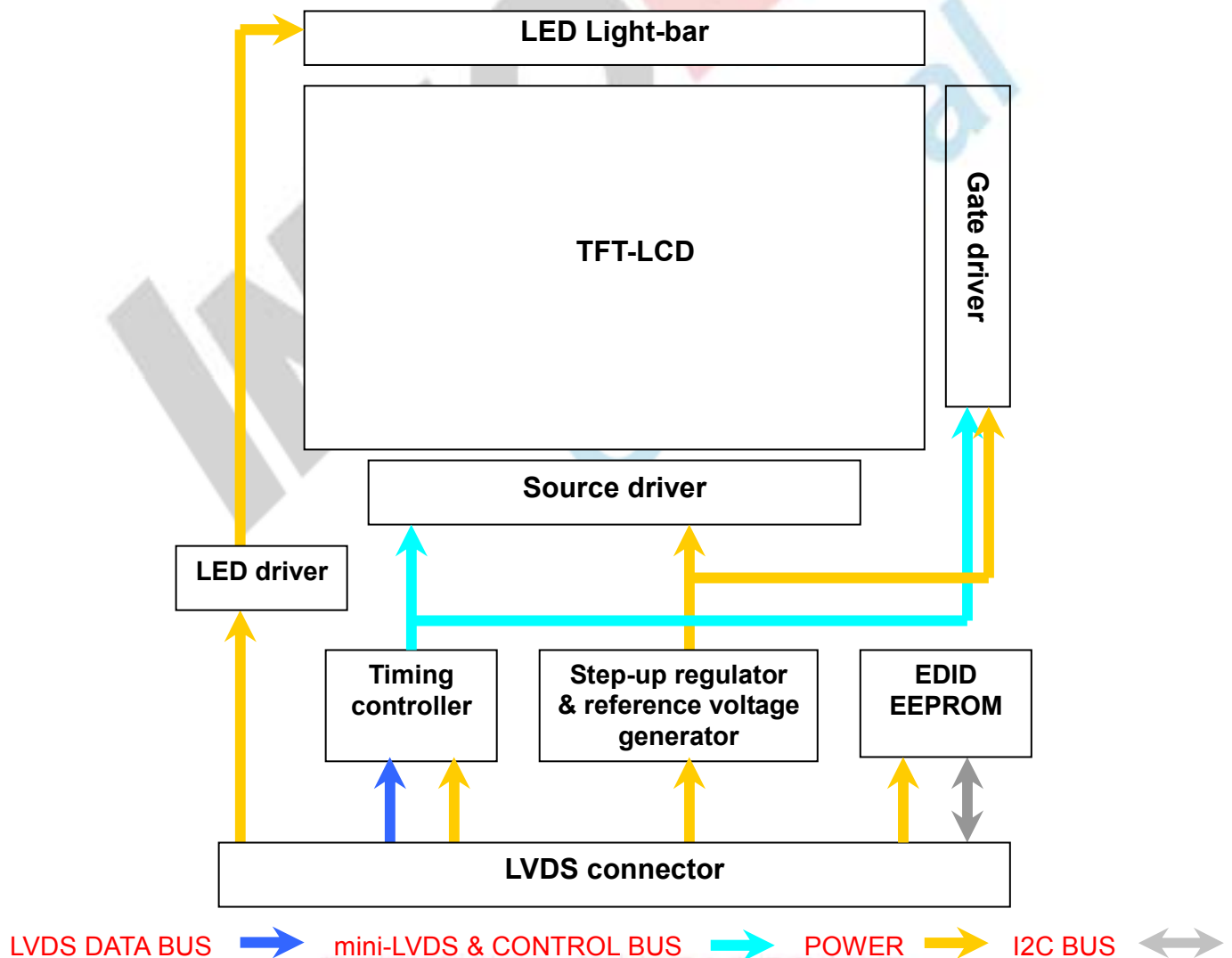

3. Optical specifications

Ambient temperature = 25°C

Item	Symbol	Condition	Specification			Unit	Remark
			Min.	Typ.	Max.		
Response time	Tr+Tf	$\theta = 0^\circ$		8	16	ms	Note 3
Contrast ratio	CR	$\theta = 0^\circ$	500	600			Note 2,4
Viewing angle	Top	$CR \geq 10$	15			deg	Note 2,4,6
	Bottom	$CR \geq 10$	30				
	Left	$CR \geq 10$	40				
	Right	$CR \geq 10$	40				
Brightness (5 points average)	Y_L		200	220		nit	Note 2,5
Color chromaticity (CIE)	W_x	$\theta = 0^\circ$	-0.02	0.313	+0.02		Note 2
	W_y			0.329			
	R_x			0.620			
	R_y			0.340			
	G_x			0.330			
	G_y			0.605			
	B_x			0.150			
	B_y			0.070			
Color Gamut	NTSC	CIE1931	56	60		%	-
White uniformity	$\bar{\delta}_{W(5)}$		0.8				Note 2,7
	$\bar{\delta}_{W(13)}$		0.65				
Cross talk	Ct				2%		Note 8

Note 1: To be measured in dark room.

Note 2: To be measured with a viewing cone of 2° by Topcon luminance meter BM-5A.

Note 3: Definition of response time:

The output signals of BM-7 are measured when the input signals are changed from "Black" to "White" (falling time) and from "White" to "Black" (rising time), respectively. The response time interval is between 10% and 90% of amplitudes. Refer to figure as below.

版權屬於群創所有，禁止任何未經授權的使用

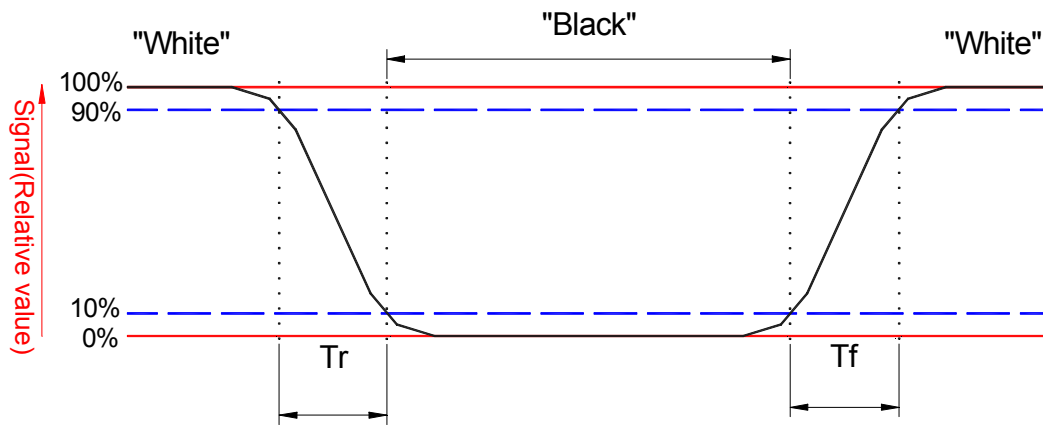

Note 4: Definition of contrast ratio:

Contrast ratio is calculated with the following formula:

$$\text{Contrast ratio (Avg of 5pts)} = \frac{L_{\text{white (Avg of 5pts.)}}}{L_{\text{Black (Avg of 5pts.)}}}$$

Note 5: Driving current for LED should be 20 mA.

Luminance is measured at the following thirteen points (1~13):

$$Y_L = (Y_3 + Y_5 + Y_7 + Y_{11} + Y_{12}) / 5$$

Note 6: Definition of viewing angle

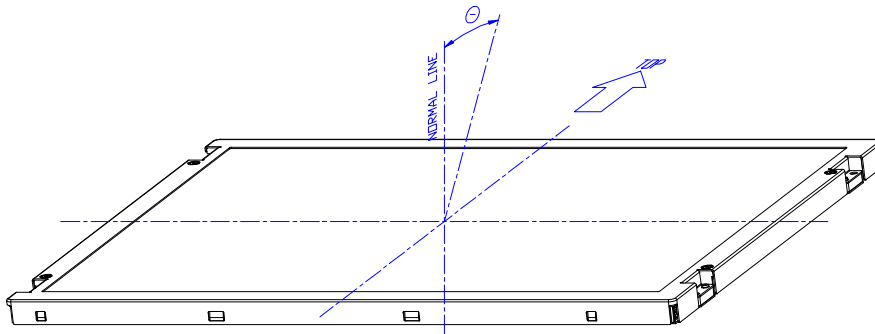

Note 7: Definition white uniformity

Luminance is measured at the following thirteen points (1~13):

$$\delta_{W(13)} = \frac{\text{Minimum brightness of thirteen points}}{\text{Maximum brightness of thirteen points}}$$

$$\delta_{W(5)} = \frac{\text{Minimum brightness of five points}}{\text{Maximum brightness of five points}}$$

版權屬於群創所有，禁止任何未經授權的使用

13 point measuring locations refer to the point 1, 2, 3, 4, 5, 6, 7, 8, 9, 10, 11, 12 and 13.
 5 point measuring locations refer to the point 3, 5, 7, 11 and 12.

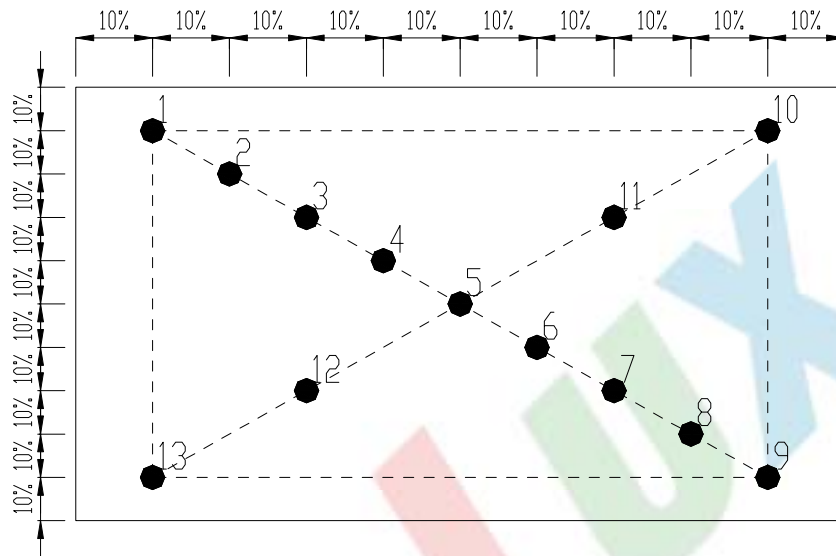

Note 8:

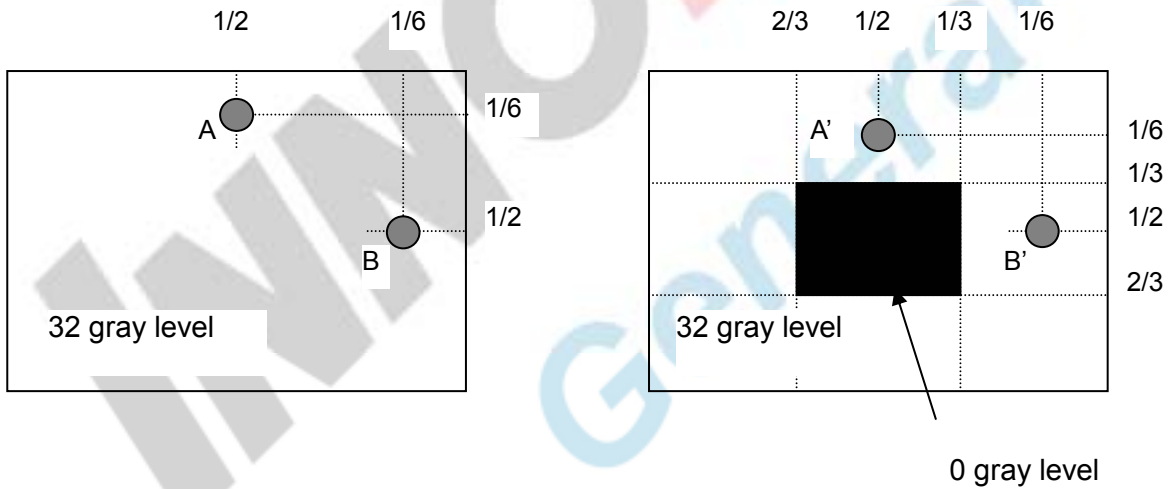

Unit: percentage of dimension of display area

$|L_A - L_{A'}| / L_A \times 100\% = 2\% \text{ max.}$, L_A and $L_{A'}$ are brightness at location A and A'

$|L_B - L_{B'}| / L_B \times 100\% = 2\% \text{ max.}$, $L_{B'}$ and L_B are brightness at location B and B'

版權屬於群創所有，禁止任何未經授權的使用

4. Reliability test items

Test Item	Test Condition	Judgment	Remark
High temperature storage	60°C, 240 hours	Note 1	Note 2
Low temperature storage	-20°C, 240 hours	Note 1	Note 2
High temperature & high humidity operation	40°C, 90% RH, 240 hours (No condensation)	Note 1	Note 2
High temperature operation	50°C, 240 hours	Note 1	Note 2
Low temperature operation	0°C, 240 hours	Note 1	Note 2
Thermal Shock (Non-operation)	-25°C / 30 mins ~ 65°C / 30 mins 100 cycles	Note 1	Note 2
Electrostatic discharge (ESD)	150 pF, 330Ω, Contact: ±8kV, Air: ±15kV	Note 1	
Vibration (Non-operation)	1.5G, 10 to 500 Hz random; 0.5hr in each perpendicular axes (X, Y, Z).	Note 1	Note 2
Mechanical shock (Non-operation)	220G/2ms, Half sine wave, ±X, ±Y, ±Z one time for each direction	Note 1	Note 2

Note 1: Pass: Normal display image with no obvious non-uniformity and no line defect.

Fail: No display image, obvious non-uniformity, or line defects.

Partial transformation of the module parts should be ignored.

Note 2: Evaluation should be tested after storage at room temperature for more than one hour.

版權屬於群創所有，禁止任何未經授權的使用

5. Safety

5-1. Sharp edge requirements

There will be no sharp edges or corners on the display assembly that could cause injury.

5-2. Materials

a. Toxicity

There will be no carcinogenic materials used anywhere in the display module. If toxic materials are used, they will be reviewed and approved by the responsible InnoLux Toxicologist.

b. Flammability

All components including electrical components that do not meet the flammability grade UL94-V0 in the module will complete the flammability rating exception approval process. The printed circuit board will be made from material rated 94-V0 or better. The actual UL flammability rating will be printed on the printed circuit board.

c. Capacitors

If any polarized capacitors are used in the display assembly, provisions will be made to keep them from being inserted backwards.

6. Display quality

The display quality of the color TFT-LCD module should be in compliance with the InnoLux incoming inspection standard.

7. Handling precaution

- (1) Do not apply rough force such as bending or twisting to the module during assembly.
- (2) To assemble or install module into user's system can be only in clean working areas. The dust and oil may cause electrical short or worsen the polarizer.
- (3) It's not permitted to have pressure or impulse on the module because the LCD panel and backlight will be damaged.
- (4) Always follow the correct power sequence when LCD module is connecting and operating.
- (5) Do not pull the I/F connector in or out while the module is operating.
- (6) Do not disassemble the module.
- (7) Use a soft dry cloth without chemicals for cleaning, because the surface of polarizer is very soft and easily scratched.
- (8) It is dangerous that moisture come into or contacted the LCD module, because moisture may damage LCD module when it is operating.
- (9) High temperature or humidity may reduce the performance of module. Please store LCD module within the specified storage conditions.

版權屬於群創所有，禁止任何未經授權的使用

8-2. Carton label

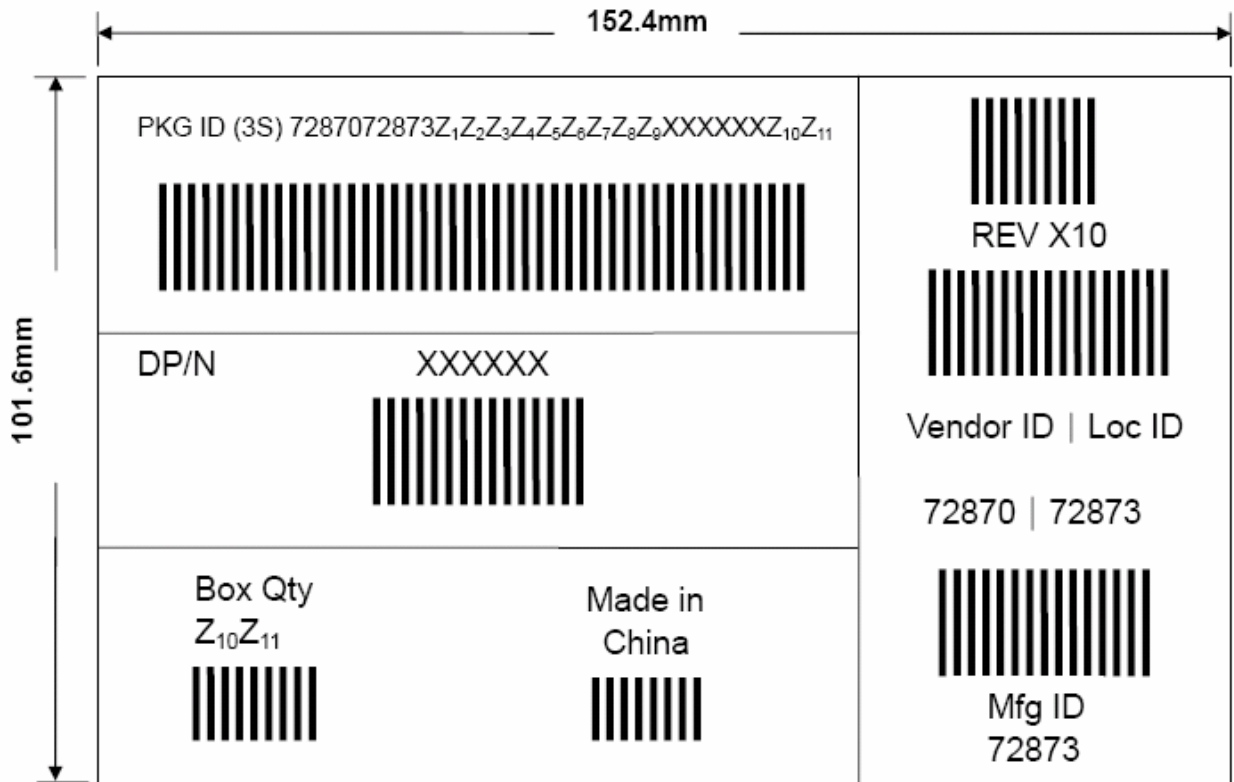

Serial ID :

(3S) 72870 72873 Z₁Z₂Z₃ Z₄Z₅Z₆Z₇Z₈Z₉ XXXXXX Z₁₀Z₁₁

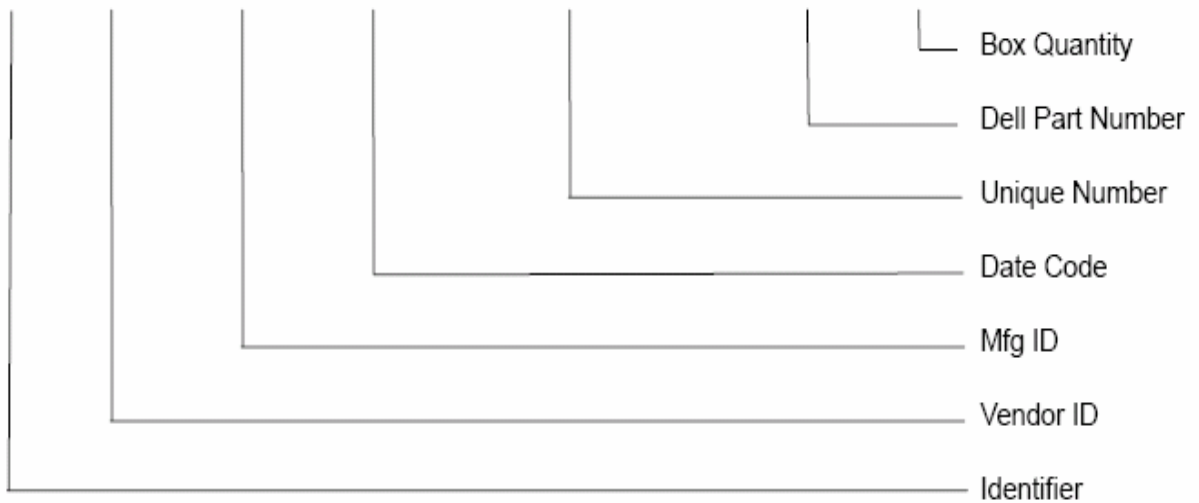

版權屬於群創所有，禁止任何未經授權的使用

9. Packing Form

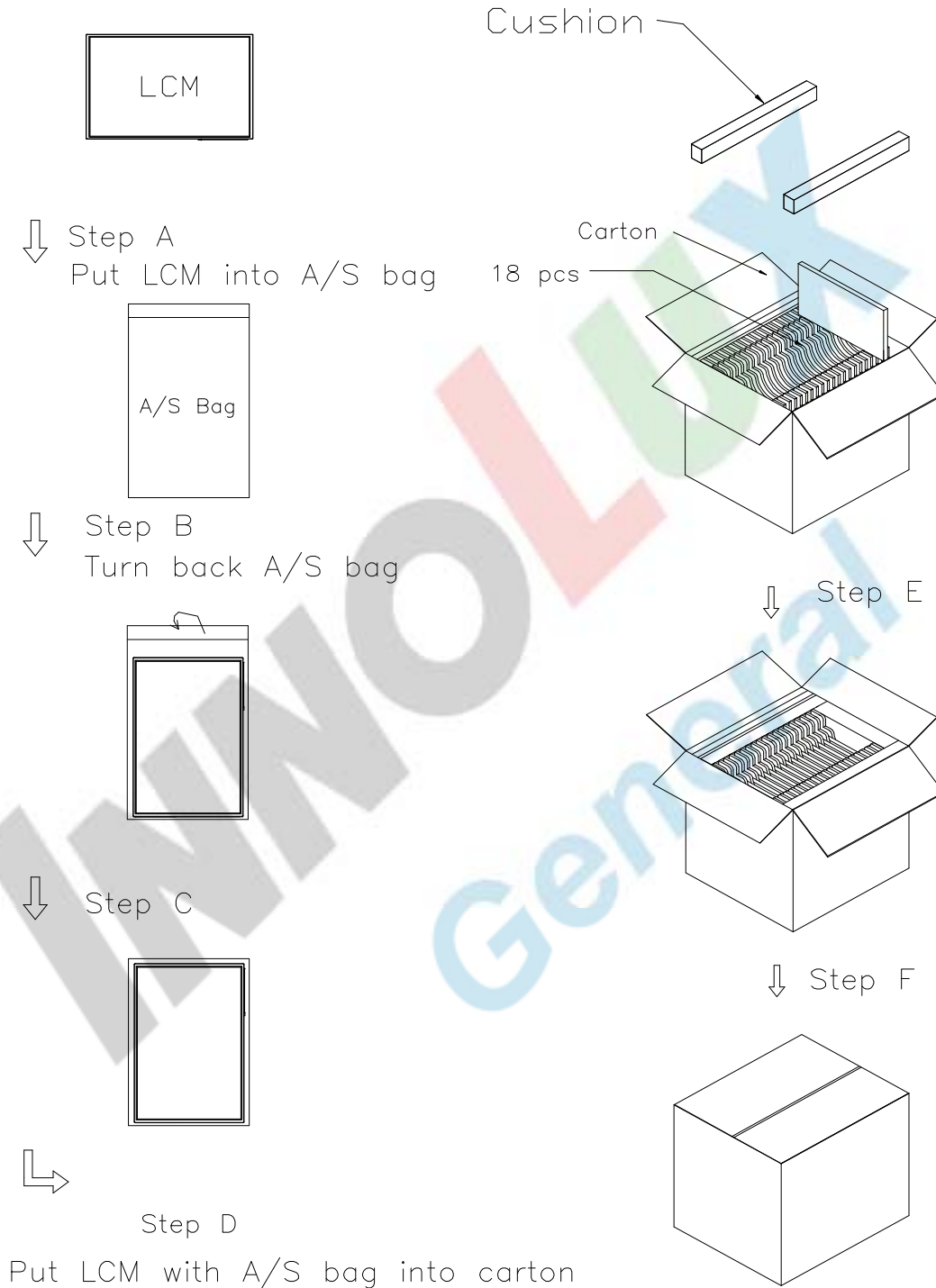

版權屬於群創所有，禁止任何未經授權的使用

10. Mechanical Drawings

10-1 Front Side

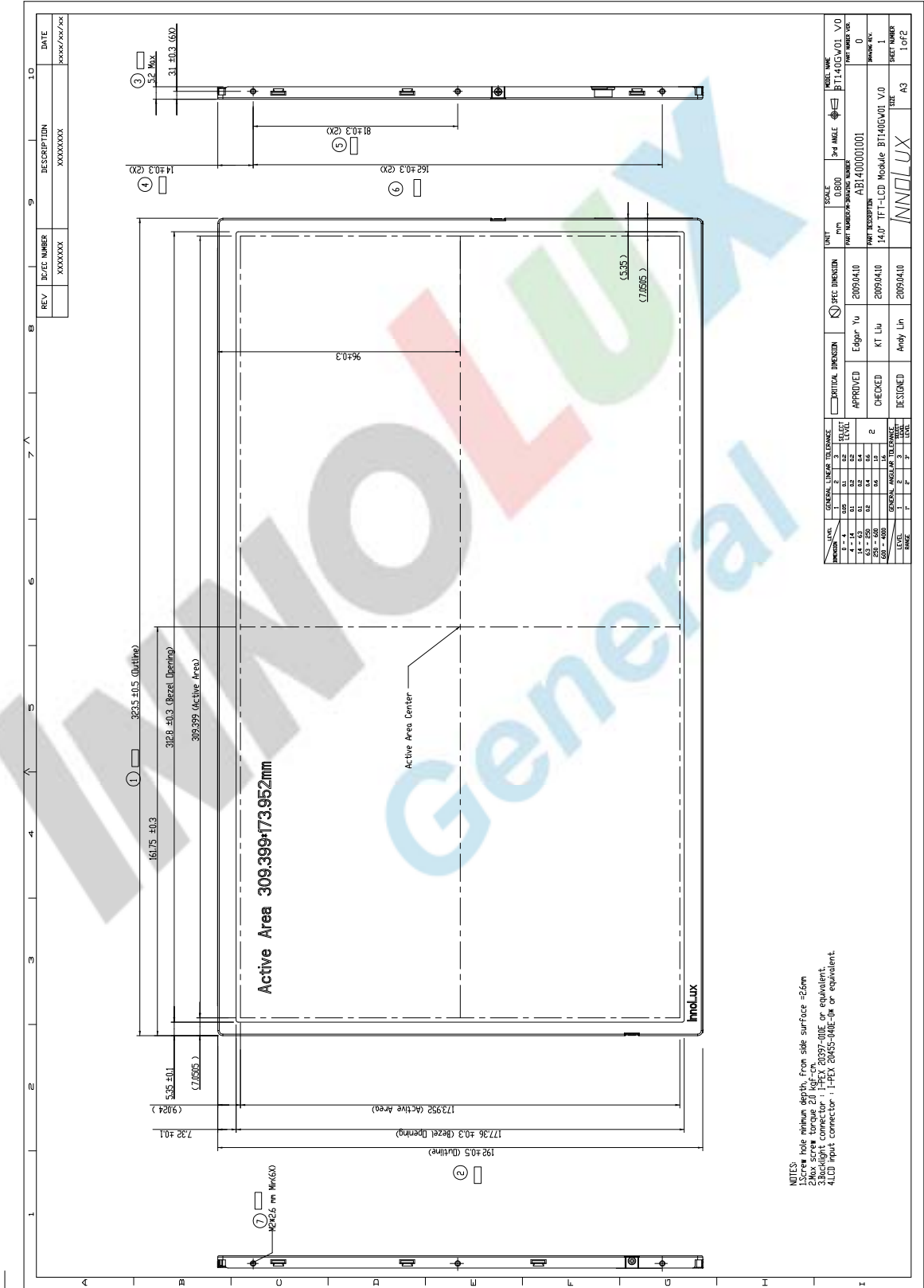

NOTES:
 1. Screw hole minimum depth, from side surface =2.6mm
 2. Backlight connector : I-PEX 20097-010E or equivalent.
 3. Backlight connector : I-PEX 20405-040E-0r or equivalent.
 4. LCD input connector : I-PEX 20405-040E-0r or equivalent.

版權屬於群創所有，禁止任何未經授權的使用

10-2 Rear side

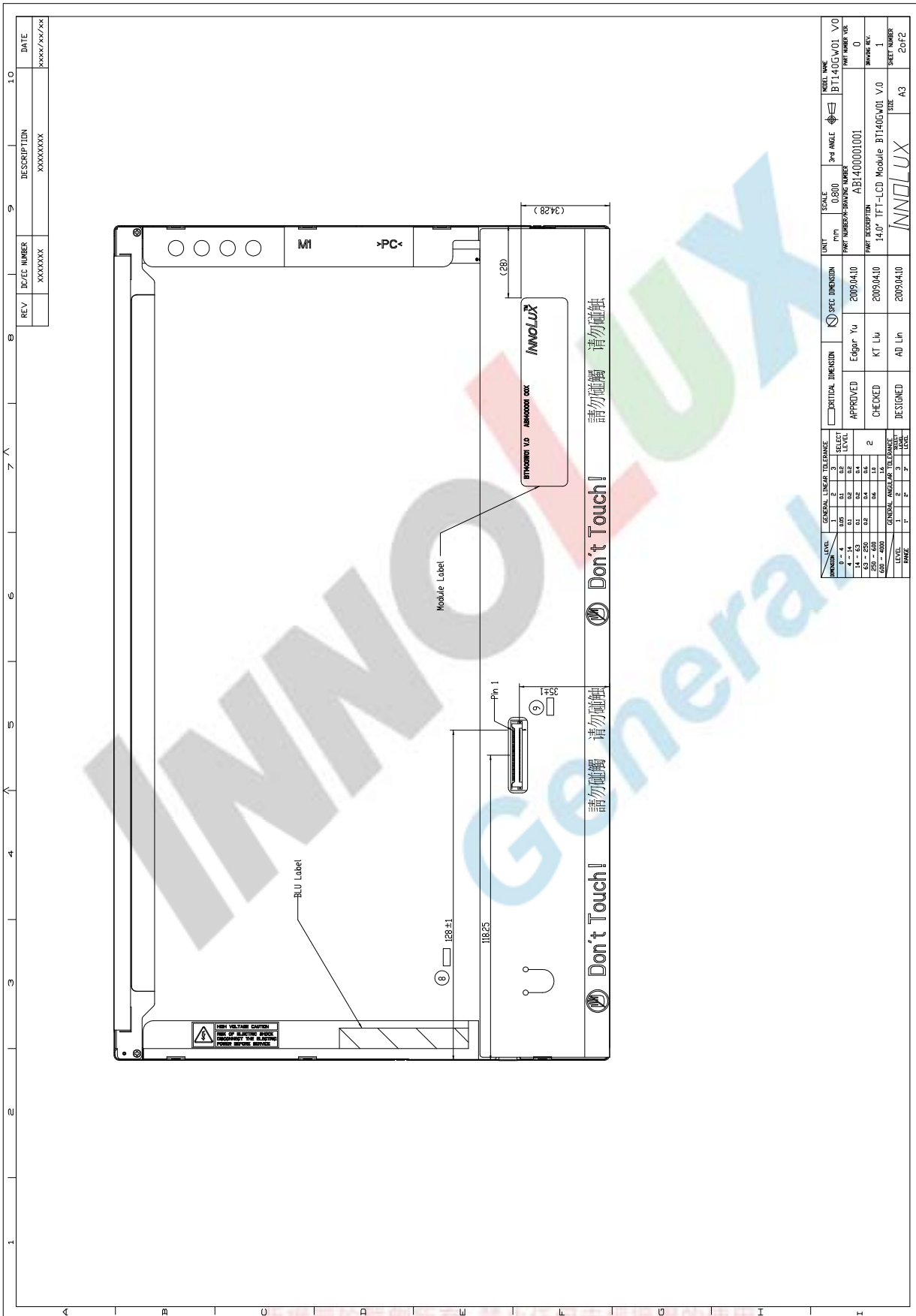

Appendix: EDID Code

	Byte	Field Name and Comments	Value	Value
	(hex)		(hex)	(binary)
Header	0	Header	00	00000000
	1	Header	FF	11111111
	2	Header	FF	11111111
	3	Header	FF	11111111
	4	Header	FF	11111111
	5	Header	FF	11111111
	6	Header	FF	11111111
	7	Header	00	00000000
Vendor / Product EDID Version	8	EISA manufacture code = 3 Character ID	25	00100101
	9	EISA manufacture code (Compressed ASCII)	CC	11001100
	0A	Panel Supplier Reserved – Product Code	02	00000001
	0B	Panel Supplier Reserved – Product Code	00	00000000
	0C	LCD module Serial No - Preferred but Optional (“0” if not used)	00	00000000
	0D	LCD module Serial No - Preferred but Optional (“0” if not used)	00	00000000
	0E	LCD module Serial No - Preferred but Optional (“0” if not used)	00	00000000
	0F	LCD module Serial No - Preferred but Optional (“0” if not used)	00	00000000
	10	Week of manufacture-->--	00	00000000
	11	Year of manufacture – 1990 (ex. 2005-1990=15) -->2009	13	00010011
	12	EDID structure version # = 1	01	00000001
	13	EDID revision # = 3	03	00000011
	Display Parameters	14	Video I/P definition = Digital I/P (80h)	90
15		Max H image size = (309.3=31 cm)	1F	00100010
16		Max V image size = (173.9=17 cm)	11	00010011
17		Display gamma = (gamma ×100)-100 = Example: (2.2×100) – 100 = 120	78	01111000
18		Feature support (no DPMS, Active off, RGB, timing BLK 1)	0A	00001010
Panel Color Coordinates	19	Red/Green Low bit (RxRy/GxGy)	C8	11001000
	1A	Blue/White Low bit (BxBy/WxWy)	85	10000110
	1B	Red x Rx=0.62	9E	10011110
	1C	Red y Ry=0.34	57	01010111
	1D	Green x Gx=0.33	54	01010100
	1E	Green y Gy=0.605	9B	10011011
	1F	Blue x Bx=0.15	26	00100110
	20	Blue y By=0.07	12	00010010
	21	White X Wx=0.313	50	01001110
22	White Y Wy=0.329	54	01010011	
Established Timings	23	Established timings 1 (00h if not used)	00	00000000
	24	Established timings 2 (00h if not used)	00	00000000
	25	Manufacturer’s timings (00h if not used)	00	00000000
Standard Timing ID	26	Standard timing ID1 (01h if not used)	01	00000001
	27	Standard timing ID1 (01h if not used)	01	00000001
	28	Standard timing ID2 (01h if not used)	01	00000001
	29	Standard timing ID2 (01h if not used)	01	00000001
	2A	Standard timing ID3 (01h if not used)	01	00000001
	2B	Standard timing ID3 (01h if not used)	01	00000001
	2C	Standard timing ID4 (01h if not used)	01	00000001
	2D	Standard timing ID4 (01h if not used)	01	00000001
	2E	Standard timing ID5 (01h if not used)	01	00000001
	2F	Standard timing ID5 (01h if not used)	01	00000001
	30	Standard timing ID6 (01h if not used)	01	00000001
	31	Standard timing ID6 (01h if not used)	01	00000001
	32	Standard timing ID7 (01h if not used)	01	00000001

	33	Standard timing ID7 (01h if not used)	01	00000001
	34	Standard timing ID8 (01h if not used)	01	00000001
	35	Standard timing ID8 (01h if not used)	01	00000001
Timing Descriptors #1	36	Pixel Clock/10,000 (LSB) (Pixel Clock=71.1MHz)	C6	01110100
	37	Pixel Clock/10,000 (MSB) (Pixel Clock=71.1MHz)	1B	00011101
	38	Horizontal Active = 1366 pixels (lower 8 bits)	56	01010110
	39	Horizontal Blanking (Thbp) = 127 pixels (lower 8 bits)	7F	11000010
	3A	Horizontal Active/Horizontal blanking (Thbp) (upper4:4 bits)	50	01010000
	3B	Vertical Active = 768 lines	00	00000000
	3C	Vertical Blanking (Tvbp) = 25 lines (DE Blanking typ. for DE only panels)	19	00100110
	3D	Vertical Active : Vertical Blanking (Tvbp) (upper4:4 bits)	30	00110000
	3E	Horizontal Sync, Offset (Thfp) = 31 pixels	1F	00110000
	3F	Horizontal Sync, Pulse Width = 21 pixels	15	00100000
	40	Vertical Sync, Offset (Tvfp) = 3 lines Sync Width = 4 lines	34	00110110
	41	Horizontal Vertical Sync Offset/Width upper 2 bits	00	00000000
	42	Horizontal Image Size =309mm	35	01011000
	43	Vertical image Size = 174 mm	AE	11000010
	44	Horizontal Image Size / Vertical image size	10	00010000
	45	Horizontal Border = 0 (Zero for Notebook LCD)	00	00000000
	46	Vertical Border = 0 (Zero for Notebook LCD)	00	00000000
47	Non-interlaced, Normal, no stereo, Separate sync, H/V pol Negatives, DE only note: LSB is set to "1" if panel is DE-timing only. H/V can be ignored.	1A	00011010	
Timing Descriptors #2	48	Pixel Clock/10,000 (LSB) (Pixel Clock=71.1MHz)	C6	01110100
	49	Pixel Clock/10,000 (MSB) (Pixel Clock=71.1MHz)	1B	00011101
	4A	Horizontal Active = 1366 pixels (lower 8 bits)	56	01010110
	4B	Horizontal Blanking (Thbp) = 127 pixels (lower 8 bits)	7F	11000010
	4C	Horizontal Active/Horizontal blanking (Thbp) (upper4:4 bits)	50	01010000
	4D	Vertical Active = 768 lines	00	00000000
	4E	Vertical Blanking (Tvbp) = 25 lines (DE Blanking typ. for DE only panels)	19	00100110
	4F	Vertical Active : Vertical Blanking (Tvbp) (upper4:4 bits)	30	00110000
	50	Horizontal Sync, Offset (Thfp) = 31 pixels	1F	00110000
	51	Horizontal Sync, Pulse Width = 21 pixels	15	00100000
	52	Vertical Sync, Offset (Tvfp) = 3 lines Sync Width = 4 lines	34	00110110
	53	Horizontal Vertical Sync Offset/Width upper 2 bits	00	00000000
	54	Horizontal Image Size =309 mm	35	01011000
	55	Vertical image Size = 174 mm	AE	11000010
	56	Horizontal Image Size / Vertical image size	10	00010000
	57	Horizontal Border = 0 (Zero for Notebook LCD)	00	00000000
	58	Vertical Border = 0 (Zero for Notebook LCD)	00	00000000
59	Module "A" Revision = Example: 00, 01, 02, 03, etc.	00	00011010	
Timing Descriptor #3 Dell specific information	5A	Flag	00	00000000
	5B	Flag	00	00000000
	5C	Flag	00	00000000
	5D	Dummy Descriptor	FE	11111110
	5E	Flag	00	00000000
	5F	Dell P/N 1 st Character "H"	48	01010101
	60	Dell P/N 2 nd Character "4"	34	00111000
	61	Dell P/N 3 rd Character "8"	38	00111000
	62	Dell P/N 4 th Character "4"	34	00110100
	63	Dell P/N 5 th Character "N"	4E	01001101
	64	LCD Supplier EEDID Revision #	80	10000000
65	Manufacturer P/N"00"	31	00110000	
66	Manufacturer P/N	34	00110000	

	67	Manufacturer P/N	30	00001010
	68	Manufacturer P/N	47	00100000
	69	Manufacturer P/N	57	00100000
	6A	Manufacturer P/N	30	00100000
	6B	Manufacturer P/N (If <13 char, then terminate with ASCII code 0Ah, set remaining char = 20h)	31	00100000
Timing Descriptors #4	6C	Flag	00	00000000
	6D	Flag	00	00000000
	6E	Flag	00	00000000
	6F	Data Type Tag:	00	00000000
	70	Flag	00	00000000
	71	Reserved	00	00000000
	72	Reserved	00	00000000
	73	Reserved	00	00000000
	74	Reserved	00	00000000
	75	Reserved	00	00000000
	76	Reserved	00	00000000
	77	Reserved	00	00000000
	78	Reserved	00	00000000
	79	Number of LVDS receiver chips = '01' or '02'	01	00000001
	7A	BIST Enable: Yes = '01' No = '00'	01	00000001
7B	(If <13 char, then terminate with ASCII code 0Ah, set remaining char = 20h)	0A	00001010	
7C	(If <13 char, then terminate with ASCII code 0Ah, set remaining char = 20h)	20	00100000	
7D	(If <13 char, then terminate with ASCII code 0Ah, set remaining char = 20h)	20	00100000	
Checksum	7E	Extension flag (# of optional 128 EDID extension blocks to follow, Typ = 0)	00	00000000
	7F	Checksum (The 1-byte sum of all 128 bytes in this EDID block shall = 0)	9B	01101111

版權屬於群創所有，禁止任何未經授權的使用