

# mass integrated

global part distribution • product lifecycle partner  
excess inventory management • value-ad service provider



Data sheet provided by Mass Integrated

[massintegrated.com](http://massintegrated.com) • [displayalliance.com](http://displayalliance.com)

Please call +1.978.465.6190  
Email: [sales@massintegrated.com](mailto:sales@massintegrated.com)



ISO 9001: 2008

Mass Integrated complies with all DMCA takedown notices. Please send a formal DMCA Takedown Notice to Mass Integrated Systems, Inc. • 18 Henry Graf Jr. Road, Unit 1 • Newburyport, MA 01950.



# Chunghwa Picture Tubes, Ltd.

## Technical Specification

To :

Date : 2006/10/20

***CPT TFT-LCD***

**CLAA141WB05A**

APPROVED BY	CHECKED BY	PREPARED BY

**Prepared by : Design General Division**

**CHUNGHWA PICTUER TUBES, LTD.**

1127 Hopin Rd., Padeh, Taoyuan, Taiwan 334, R.O.C.  
TEL: +886-3-3675151 FAX: +886-3-377-3001

Doc. No:	CLAA141WB05A -tentative-20061020	Issue Date:	2006/10/20
----------	----------------------------------	-------------	------------





## 1. OVERVIEW

CLAA141WB05A(with LVDS interface) is 14.1" color TFT-LCD (Thin Film Transistor Liquid Crystal Display) module composed of LCD panel , LVDS driver ICs , control circuit , and backlight.

By applying 6 bits digital data, 1280×800, 262K color images are displayed on the 14.1" diagonal screen. Input power voltage is single 3.3V for LCD driving.

Inverter for backlight is not included in this module. General specifications are summarized in the following table:

ITEM	SPECIFICATION
Display Area (mm)	303.744 (H)×189.84 (V) (14.1-inch diagonal)
Number of Pixels	1280 ×3(H)×800(V)
Pixel Pitch (mm)	0.2373(H)×0.2373(V)
Color Pixel Arrangement	RGB vertical stripe
Display Mode	Normally white
Number of Colors	262,144
Optimum Viewing Angle	6 o'clock
Brightness (cd/m <sup>2</sup> )	200 cd/m <sup>2</sup> (5P) ; Lamp current 6 mA (typ.)
Viewing Angle	80/60
Power Consumption (W)	6.0 W (typ) w/o inverter
Module Size (mm)	319.5(W)×205.5(H)×5.5(D) ( Max )
Module Weight (g)	400(typ) ; 420(max)
Backlight Unit	1CCFL
Surface Treatment	Glare (Haze value 12%); Hardness: 3H

[Note] : Sign "( )" means tentative value.

The LCD Products listed on this document are not suitable for use of aerospace equipment, submarine cables, nuclear reactor control system and life support systems. If customers intend to use these LCD products for above application or not listed in "Standard" as follows, please contact our sales people in advance.

Standard: Computer, Office equipment, Communication equipment, Test and Measurement equipment, Machine tool, Industrial robot, Audio and Visual equipment, Other consumer products.

## 2. ABSOLUTE MAXIMUM RATINGS

ITEM	SYMBOL	MIN.	MAX.	UNIT	REMARK
Power Supply Voltage for LCD	VCC	-0.3	4.0	V	
LVDS input Voltage	VIN	-0.3	VCC+0.3	V	
Static Electricity	VESDt	-250	250	V	*1)
	VESDc	-15	15	KV	
ICC Rush Current	I <sub>RUSH</sub>	--	2	A	*2)
Operation Temperature	Top	0	50	°C	*3)*4)
Storage Temperature	Tstg	-20	65	°C	*3)*4)
Starting Voltage	V <sub>SL</sub>	0	1180	V	

[Note] : \*1) Test Condition : IEC 1000-4-2 ,

VESDt : Contact discharge to input connector

VESDc : Contact discharge to module

\*2) measure with below circuit, If Vcc rise time increase then I<sub>RUSH</sub> decrease.

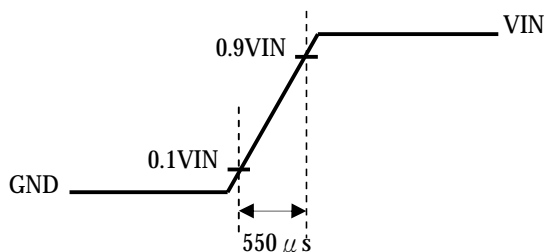
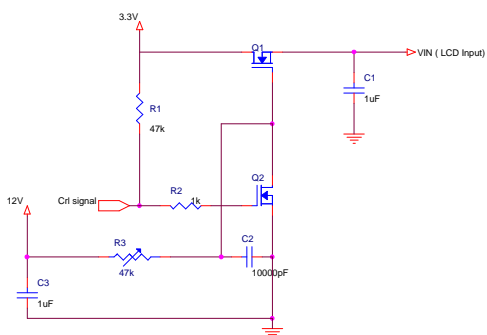

\*3) Humidity ≤ 85% RH. without condensation.

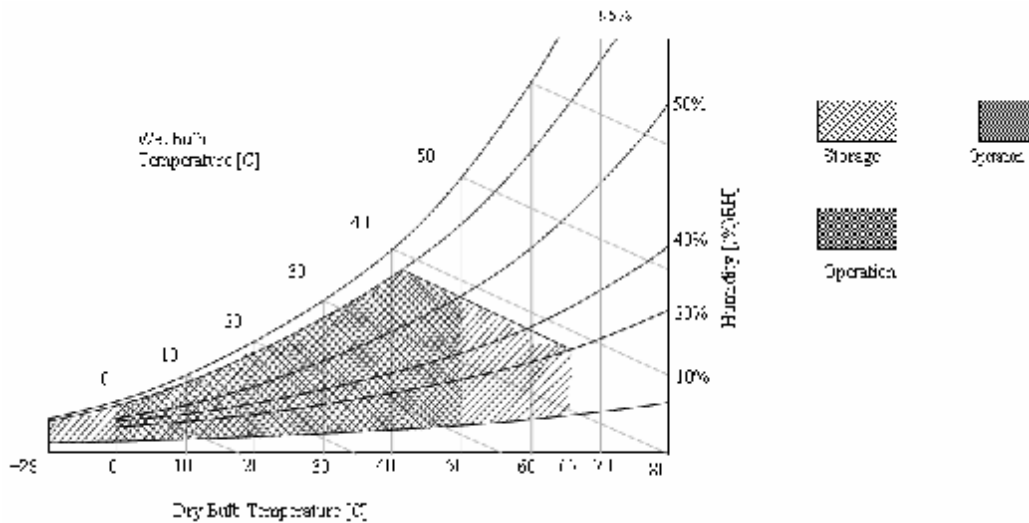

\*4) If the relative temperature and humidity out of range too long, it will affect visual of observation.

### 3. ELECTRICAL CHARACTERISTICS

#### (A) TFT LCD

ITEM	SYMBOL	MIN	TYP	MAX	UNIT	REMARK	
LCD POWER VOLTAGE	VCC	3.0	3.3	3.6	V	[Note 1]	
LCD POWER CURRENT	ICC	-	340	380	mA	[Note 2 · 3]	
LOGIC INPUT VOLTAGE (LVDS: IN+,IN-) [Note 3]	INPUT VOLTAGE	VIN	0	-	VCC	V	
	COMMON VOLTAGE	VCM	1.125	1.25	1.375	V	
	DIFFERENTIAL INPUT VOLTAGE	VID	250	350	450	mV	
	THRESHOLD VOLTAGE (HIGH)	VTH	-	-	100	mV	FOR VCM=+1.2V
	THRESHOLD VOLTAGE (LOW)	VTL	-100	-	-	mV	
DIFFERENTIAL INPUT VOLTAGE TOLERANCE	$\Delta$ VID	-	-	35	mV		
COMMON VOLTAGE TOLERANCE	$\Delta$ VCM	-	-	35	mV		

[Note 1] Power Sequence :

- 1 ms < t1 ≤ 10ms                      1 sec ≤ t5
- 0 ms < t2 ≤ 50 ms                    300 ms ≤ t6
- 0 ms < t3 ≤ 50 ms                    300 ms ≤ t7
- 0 ms < t4 ≤ 10 ms

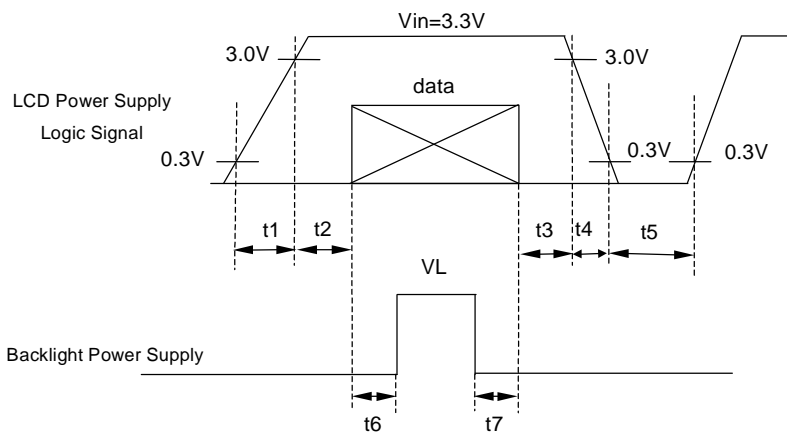

#### VCC-dip state

- (1) when  $2.7 \leq VCC < 3.0V$ ,  $t_d \leq 10$  ms
- (2) when  $VCC < 2.7V$ , VCC-dip condition should as the VCC-turn-off condition.

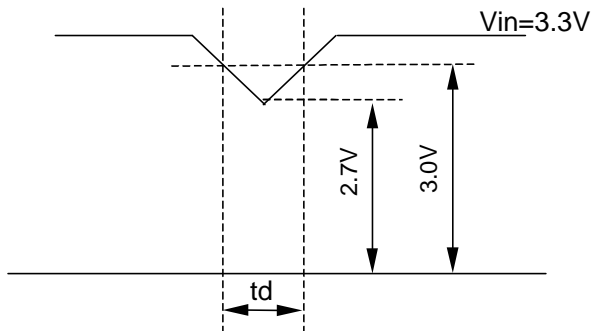

[Note 2]

Typical value is 0~63 gray level.(horizontal line Pattern)  
 800 line mode , VCC= +3.3V fCLKin =71.1MHz (fV=60Hz)

[Note 3]

LVDS Signal Definite :

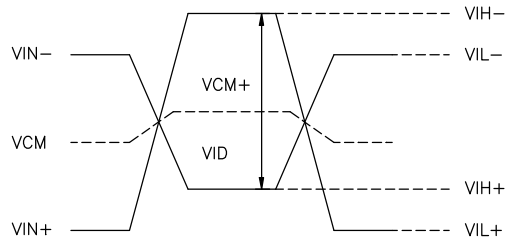
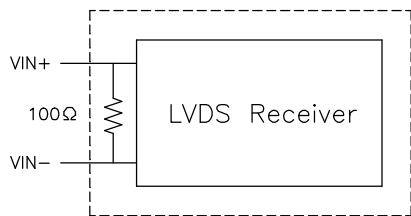

$$VID = VIN_+ - VIN_-$$

$$\Delta VCM = |VCM_+ - VCM_-|$$

$$\Delta VID = |VID_+ - VID_-|$$

$$VID_+ = |VIH_+ - VIH_-|$$

$$VID_- = |VIL_+ - VIL_-|$$

$$VCM = (VIN_+ + VIN_-) / 2$$

$$VCM_+ = (VIH_+ + VIH_-) / 2$$

$$VCM_- = (VIL_+ + VIL_-) / 2$$

VIN+ : Positive differential DATA & CLK Input  
 VIN- : Negative differential DATA & CLK Input

(B) BACK LIGHT

						Ta=25°C	
ITEM	SYMBOL	MIN	TYP	MAX	UNIT	REMARK	
Lamp Voltage(IL=6.0mA)	VL	-	(640)	-	V		
Lamp Current	IL	3.0	6.0	6.5	mA	*1)	
Inverter Frequency	FI	50	-	60	kHz	*3)	
Lamp Life Time(IL=6.0mA)	Life L	15,000	-	-	hr	*2)	
Start up Lamp Voltage	Ta=0°C	-	-	(1420)	V	*4)	
	Ta=25°C	-	-	(1180)			

\*1)Measure method : galvanometer connect to low voltage

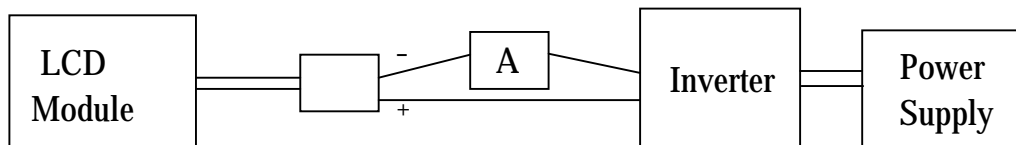

\*2) Definition of the lamp life time :

- a. Luminance (L) under 50% of specification starting lamp voltage
- b. Starting Lamp Voltage: Vs=1180 ,Ta=25°C, IL=Max 6.0 mA

[Note]

If the driving waveform of Lamp is asymmetric, the distribution of mercury inside the lamp tube will become unequally or will deplete the Ar gas in it. Then it may cause the abnormal phenomenon of lighting-up. Therefore, designers have to try their best to for fill the conditions under the inverter designing-stage as below:

- The degrees of unbalance : < 10%
- The ratio of wave height : < √2 ±10%

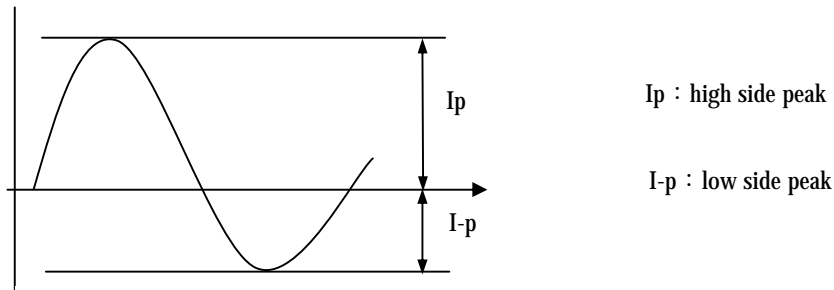

A : The degrees of unbalance =  $| I_p - I-p | / I_{rms} \times 100 (\%)$

B : The ratio of wave height =  $I_p \text{ (or } I-p) / I_{rms}$

**\*3) Frequency in this range can make the characteristics of electric and optics maintain in +/- 10% except hue.**

Lamp frequency of inverter may produce interference with horizontal synchronous frequency, and this may cause horizontal beat on the display. Therefore, please adjust lamp frequency, and keep inverter as far from module as possible or use electronic shielding between inverter and module to avoid the interference.

Under optimum operate frequency range (50~80 KHz), will not effect panel life-time and reliability .

**\*4) For keeping good lighting situation ,when design the inverter, it must be considered that the voltage large than starting lamp voltage.**

### 4.Connector Interface PIN & Function

(a) CN1(Interface signal)

Outlet connector: FI-XB30SL-HF10 (JAE)

Link connector: FI-X30H (JAE, Link Type )

Pin No.	SYMBOL	Function
1	Vss	Ground
2	Vcc	+3.3V
3	Vcc	+3.3V
4	V_EDID	DDC 3.3V Power
5	BIST	Panel BIST test *1)
6	CLK_EDID	DDC Clock
7	DATA_EDID	DDC Data
8	R0M	minus signal of channel 0(LVDS)
9	R0P	plus signal of channel 0(LVDS)
10	Ground	Ground
11	R1M	minus signal of channel 1(LVDS)
12	R1P	plus signal of channel 1(LVDS)
13	Ground	Ground
14	R2M	minus signal of channel 2(LVDS)
15	R2P	plus signal of channel 2(LVDS)
16	Ground	Ground
17	RCLKM	minus signal of clock channel (LVDS)
18	RCLKP	plus signal of clock channel (LVDS)
19	Ground	Ground
20	NC	No connect
21	NC	VCOM test provided , but customer-end unused ; No Connect (open)
22	NC	No connect
23	NC	No connect
24	NC	No connect
25	NC	No connect
26	NC	No connect
27	NC	No connect
28	NC	No connect
29	NC	No connect
30	NC	No connect

\*1)BIST(Build in self-test pattern)

BIST pin = low(GND) : Normal

BIST pin = high(VCC) : Self-test mode

- 1) Self-test Display Pattern will change when pin 5 is at high voltage and no LVDS input signals would be detected, as following patterns runs continuously. ( Black, White, Red, Green and Blue or White, Black, Red, Green and Blue).
- 2) Pattern sequence  
 Pattern1à Pattern2à Pattern3à Pattern4à Pattern5à Pattern1à .....

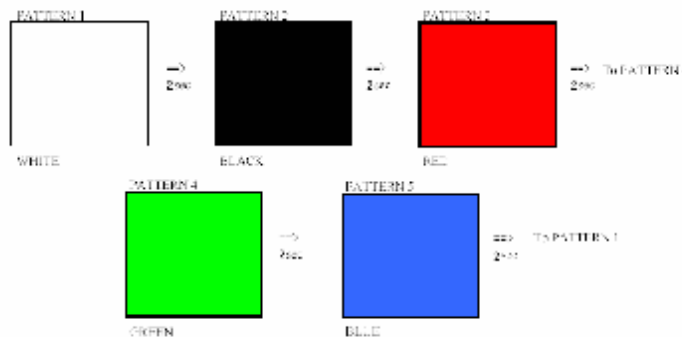

Recommendable Display Pattern Sequence

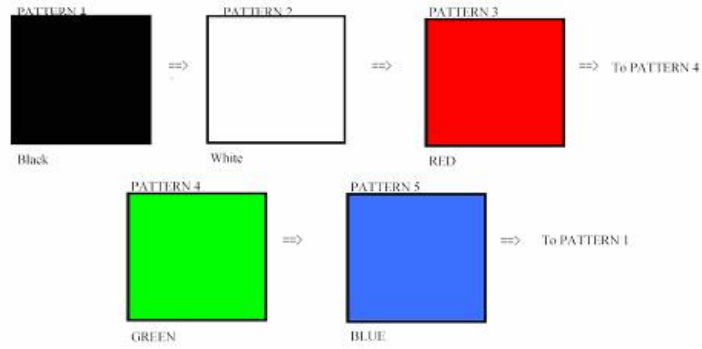

**Alternative Display Pattern Sequence**

**(b) CN2 (BACKLIGHT)**

Backlight-side connector: BHSR-02VS-1 (JST)

Inverter-side connector: SM02B-BHSS-1 (JST)

Pin No.	Symbol	Function
1	CTH	VBLH (High)
2	CTL	VBLL (Low)

[Note] : VBLH-VBLL=VL

### 5. INTERFACE TIMING CHART

(a). LVDS input time sequence

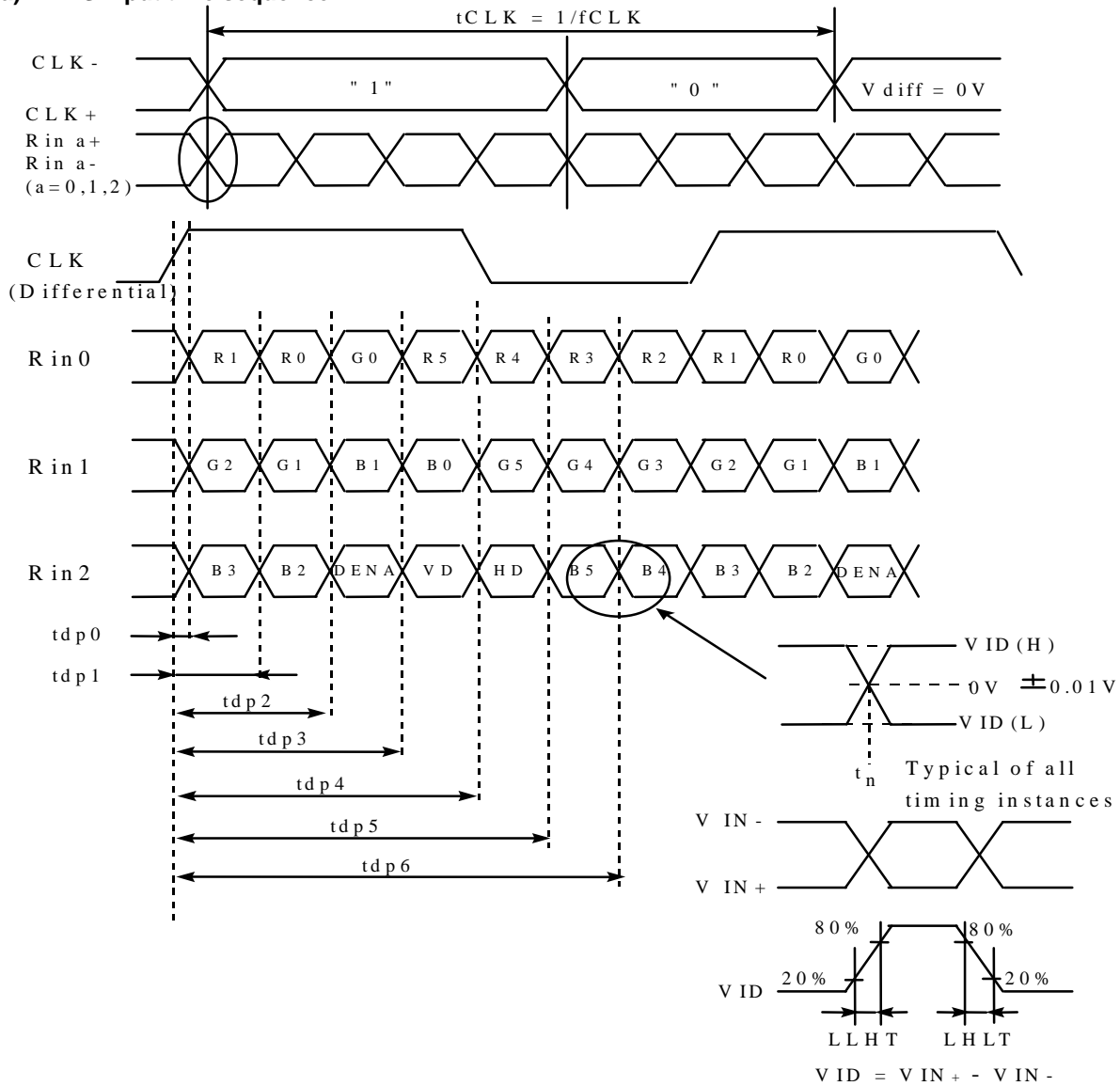

(b) LCD input time sequence

(1) Timing Chart

a. Horizontal signal:

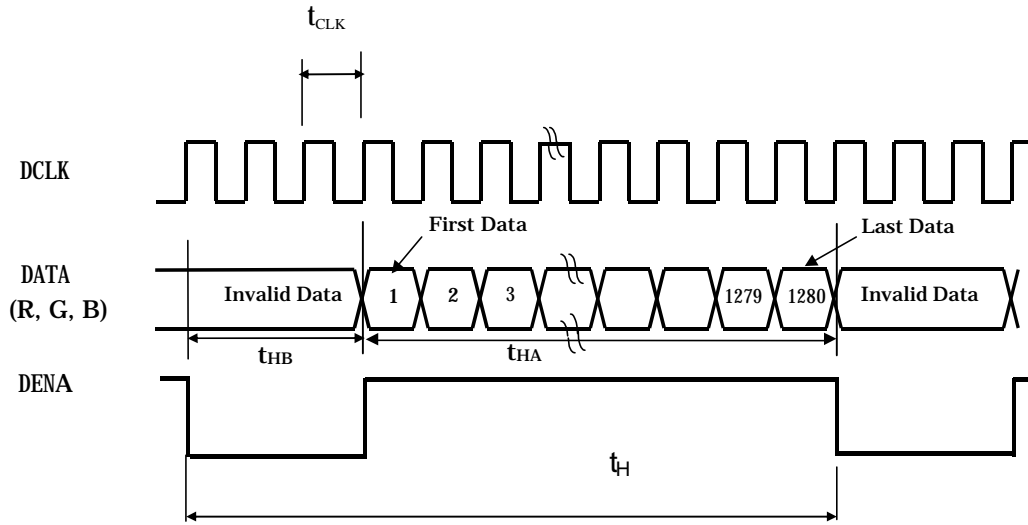

b. Vertical signal:

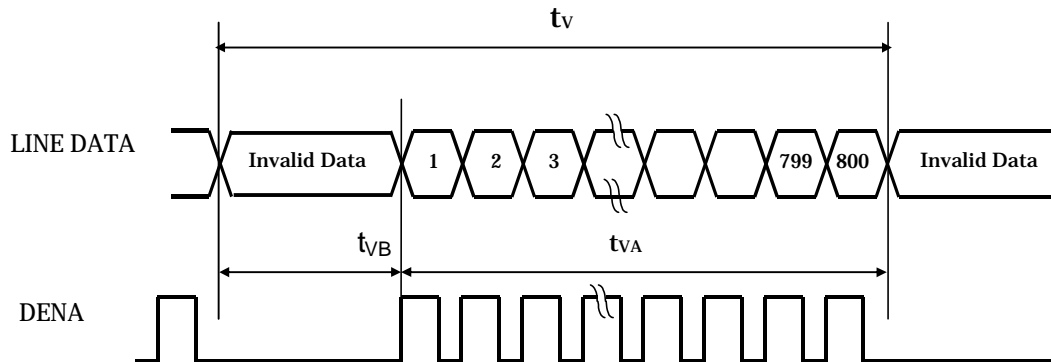

(3) Data Mapping

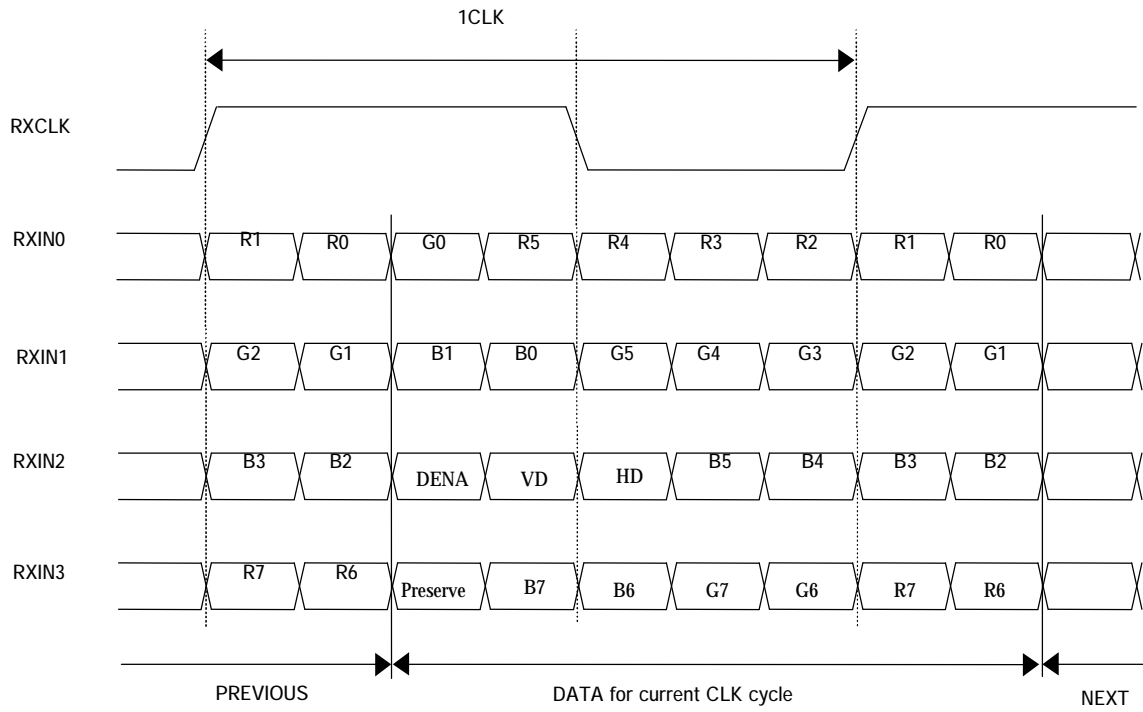

**(2) Timing Chart**

ITEM			SYMBOL	MIN	TYP	MAX	UNIT	
LVDS Input Timing	CLK frequency		fCLKin	62.83	71.11	80.42	MHz	
	CLK period		tCLKin	12.43	14.06	15.92	ns	
LCD input signal ( LVDS Tx Input , Rx output )	DENA	Horizontal	Total	t <sub>H</sub>	1400	1440	1480	tCLK
			Active	t <sub>HA</sub>	1280	1280	1280	tCLK
			Blank	t <sub>HB</sub>	120	160	200	tCLK
		Vertical	Frame Rate	fV	55	60	65	Hz
			Tatol	t <sub>V</sub>	816	823	836	t <sub>H</sub>
			Active	t <sub>VA</sub>	800	800	800	t <sub>H</sub>
	Blank		t <sub>VB</sub>	16	23	36	t <sub>H</sub>	

**[Note]**

- 1) Data is latched at fall edge of DCLK in this specification.
- 2) DENA (Data Enable) should always be positive polarity as shown in the timing specification.
- 3) CLKIN should appear during all invalid period.
- 4) T(period) = 1/f

(3) DATA mapping

Color	Input Data	R DATA						G DATA						B DATA					
		R5	R4	R3	R2	R1	R0	G5	G4	G3	G2	G1	G0	B5	B4	B3	B2	B1	B0
		MS B					LS B	MS B					LS B	MS B					LS B
Basic Color	Black	0	0	0	0	0	0	0	0	0	0	0	0	0	0	0	0	0	0
	Red(63)	1	1	1	1	1	1	0	0	0	0	0	0	0	0	0	0	0	0
	Green(63)	0	0	0	0	0	0	1	1	1	1	1	1	0	0	0	0	0	0
	Blue(63)	0	0	0	0	0	0	0	0	0	0	0	0	1	1	1	1	1	1
	Cyan	0	0	0	0	0	0	1	1	1	1	1	1	1	1	1	1	1	1
	Magenta	1	1	1	1	1	1	0	0	0	0	0	0	1	1	1	1	1	1
	Yellow	1	1	1	1	1	1	1	1	1	1	1	1	0	0	0	0	0	0
	White	1	1	1	1	1	1	1	1	1	1	1	1	1	1	1	1	1	1
Red	RED(0)	0	0	0	0	0	0	0	0	0	0	0	0	0	0	0	0	0	0
	RED(1)	0	0	0	0	0	1	0	0	0	0	0	0	0	0	0	0	0	0
	RED(2)	0	0	0	0	1	0	0	0	0	0	0	0	0	0	0	0	0	0
	RED(62)	1	1	1	1	1	0	0	0	0	0	0	0	0	0	0	0	0	0
	RED(63)	1	1	1	1	1	1	0	0	0	0	0	0	0	0	0	0	0	0
	Green	Green(0)	0	0	0	0	0	0	0	0	0	0	0	0	0	0	0	0	0
Green(1)		0	0	0	0	0	0	0	0	0	0	0	1	0	0	0	0	0	0
Green(2)		0	0	0	0	0	0	0	0	0	0	1	0	0	0	0	0	0	0
Green(62)		0	0	0	0	0	0	1	1	1	1	1	0	0	0	0	0	0	0
Green(63)		0	0	0	0	0	0	1	1	1	1	1	1	0	0	0	0	0	0
Blue		Blue(0)	0	0	0	0	0	0	0	0	0	0	0	0	0	0	0	0	0
	Blue(1)	0	0	0	0	0	0	0	0	0	0	0	0	0	0	0	0	0	1
	Blue(2)	0	0	0	0	0	0	0	0	0	0	0	0	0	0	0	0	1	0
	Blue(62)	0	0	0	0	0	0	0	0	0	0	0	0	1	1	1	1	1	0
	Blue(63)	0	0	0	0	0	0	0	0	0	0	0	0	1	1	1	1	1	1

[Note]

(1) Definition of gray scale:

Color(n) : n means level of gray scale . Higher n means brighter level.

(2)Data : 1= High , 0 = Low

6. BLOCK DIAGRAM

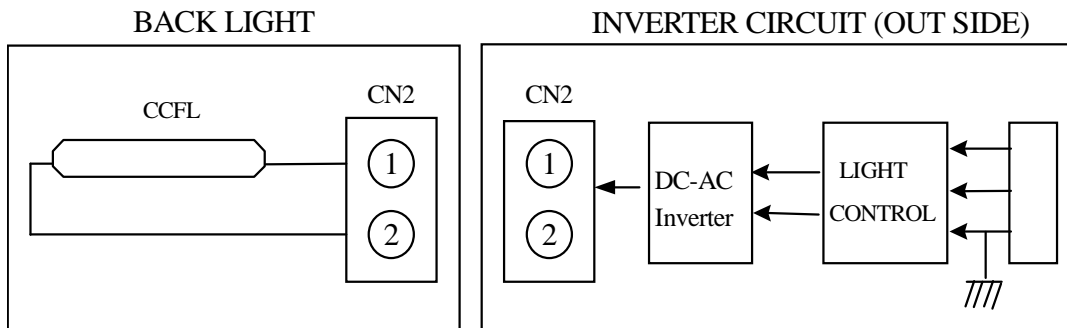
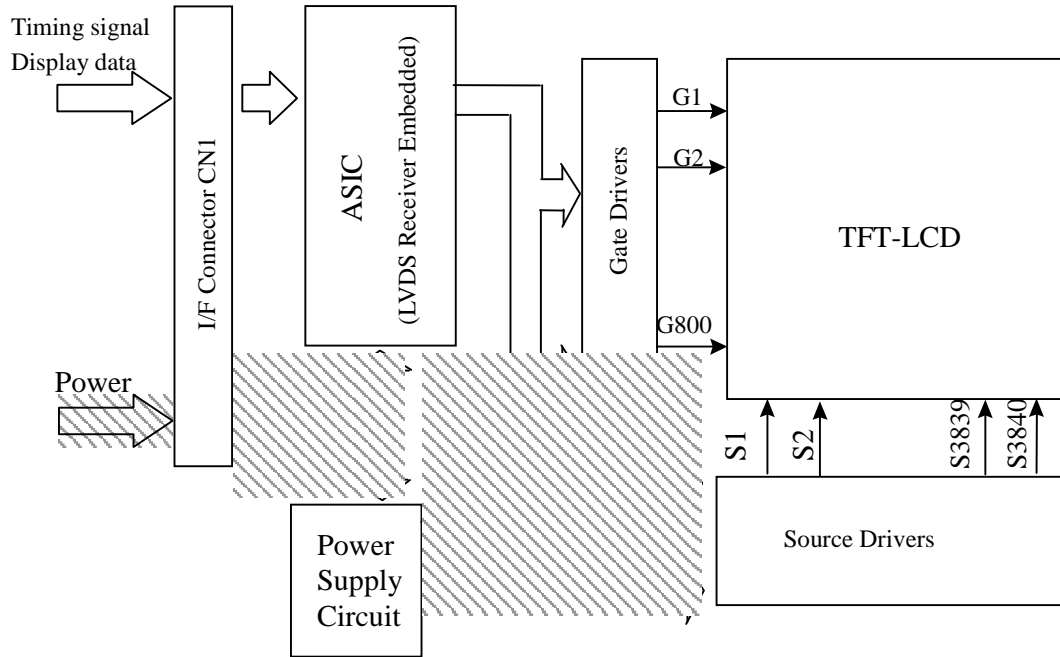

### 7.MECHANICAL SPECIFICATION

(1) Front side

The tolerance, not show in the figure, is  $\pm 0.5\text{mm}$ .

[Unit : mm]

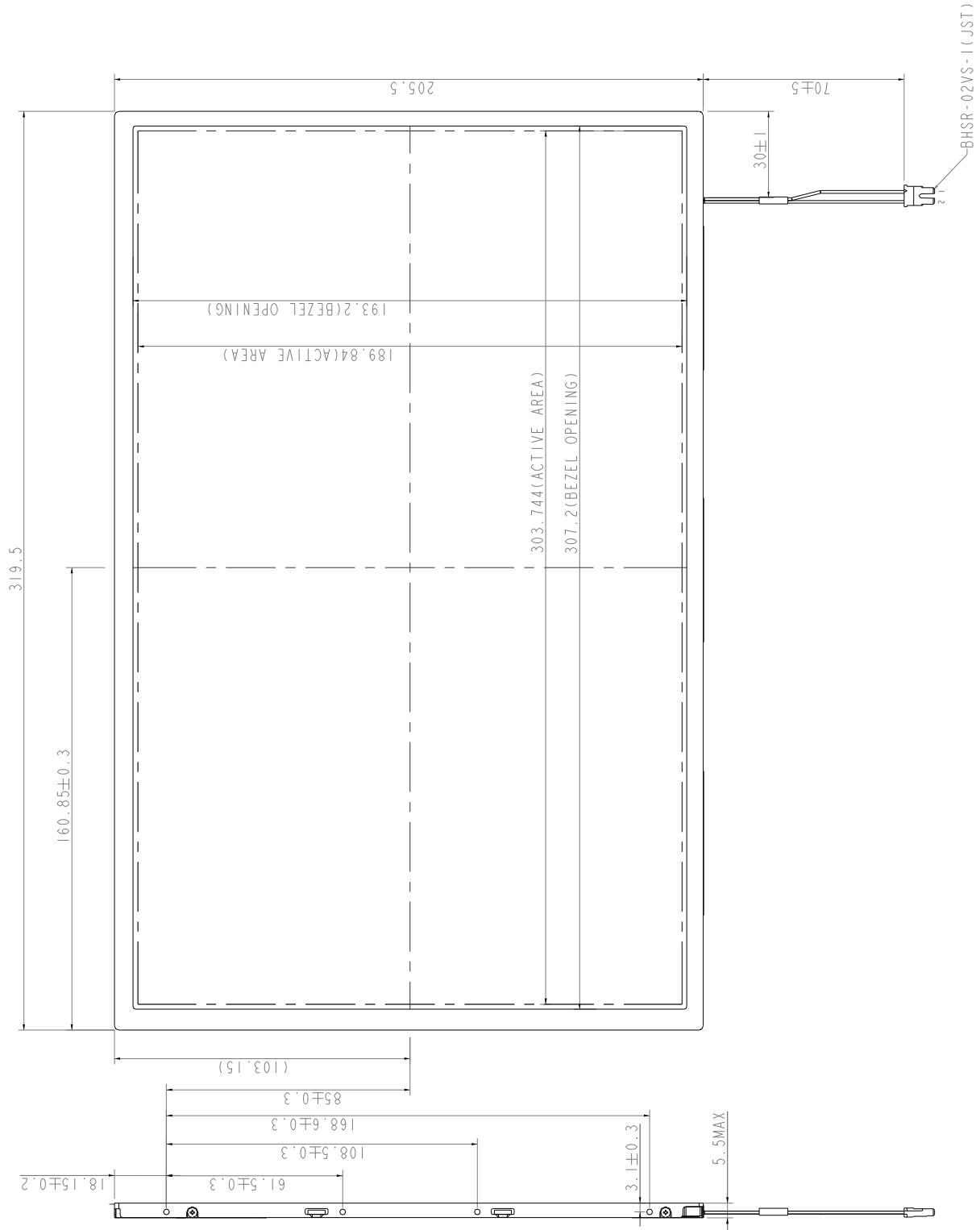

2) Rear side

The tolerance, not show in the figure, is  $\pm 0.5\text{mm}$ .

[Unit : mm]

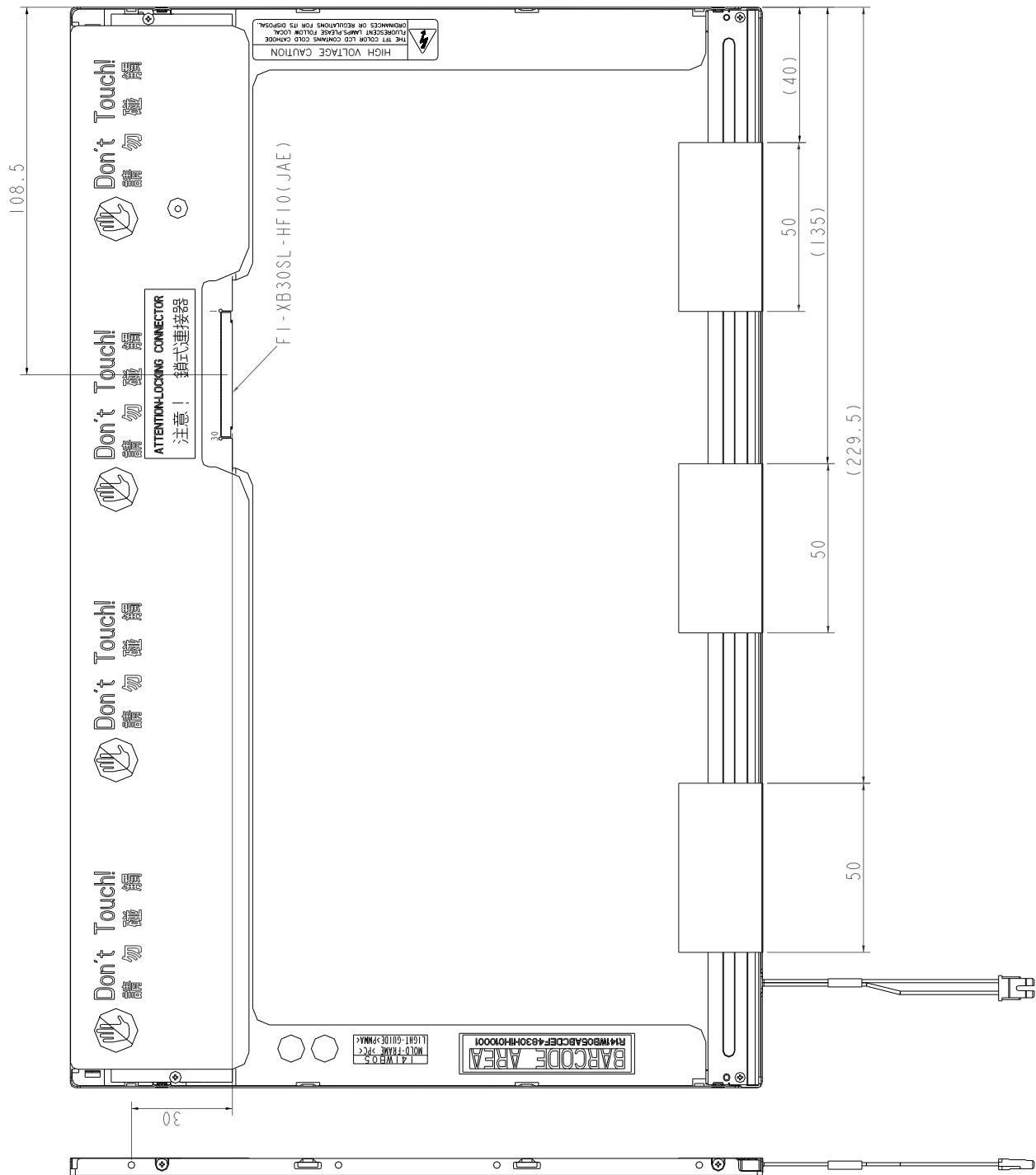

## 8. OPTICAL CHARACTERISTICS

Ta=25°C · VDD=3.3V

item	symbol	condition	min	typ	max	unit	
contrast	CR	*1)	300	350	--	--	
Luminance	L	*3) $I_L = 6 \text{ mA}$	200	--	--	cd/m <sup>2</sup>	
5P Luminance Uniformity	$\Delta L$	*4)	80	--	--	%	
Response Time	Tr	*6)	--	5	20	ms	
	Tf		--	11		ms	
View angle	Horizontal	*2) $CR \geq 10$	-35~35	-40 ~ 40	--	°	
	Vertical		$\theta^{*2)}$	-35~15		-40 ~ 20	°
Crosstalk Ratio	CMR	*7)	--	--	1	%	
Image sticking	tis	*8)	--	--	2	s	
Color Temperature Coordinate	RED	x	$\theta = \phi = 0^\circ$	0.559	0.589	0.619	--
		y		0.296	0.326	0.356	
	GREEN	x		0.285	0.315	0.345	
		y		0.510	0.540	0.570	
BLUE	x	0.123	0.153	0.183			
	y	0.095	0.125	0.155			
WHITE	x	0.283	0.313	0.343			
	y	0.299	0.329	0.359			

These items are measured using BM-5A (TOPCON) under the dark room condition (no ambient light).

Measurement Condition:  $I_L=6.0\text{mA}$

Inverter : SUMIDA PWS-400-9594

Definition of these measurement items is as follows:

(1)Definition of Contrast Ratio :  $CR = \text{ON (White) Luminance} / \text{OFF (Black) Luminance}$

(2)Definition of Viewing Angle( $\theta, \psi$ )

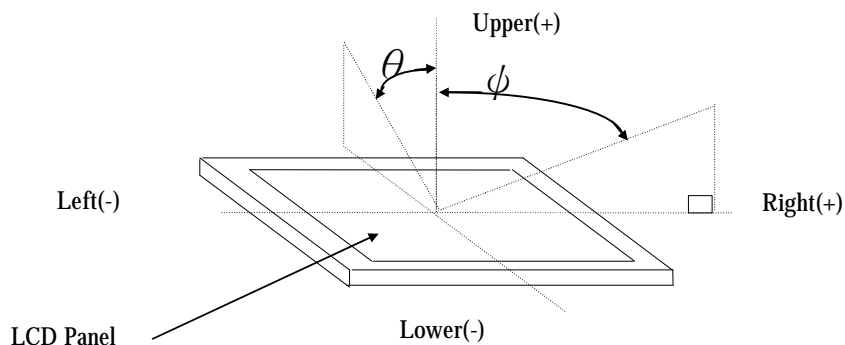

(3) Definition of Luminance and Luminance uniformity :

Definition of Average Luminance of White (L)

Measure White Luminance on the below center(5) · 5 point(5,10,11,12,13)

$$L = [L(5) + L(10) + L(11) + L(12) + L(13)] / 5$$

L(X) is corresponding to the luminance of the point X at below Figure.

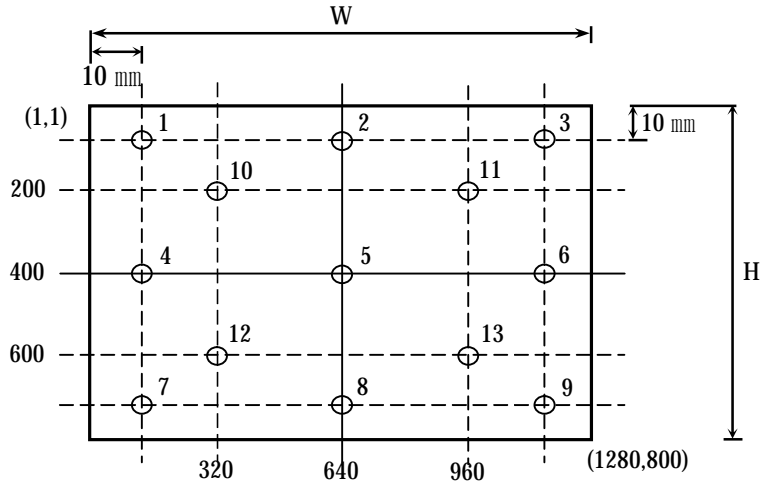

(4) Definition of Luminance Uniformity

$$\Delta L = [L(\text{MIN}) / L(\text{MAX})] \times 100$$

(5) Definition of Contrast Ratio Uniformity

$$\Delta \text{CR} = [\text{CR}(\text{MAX}) / \text{CR}(\text{MIN}) - 1] \times 100$$

(6) Definition of Response Time

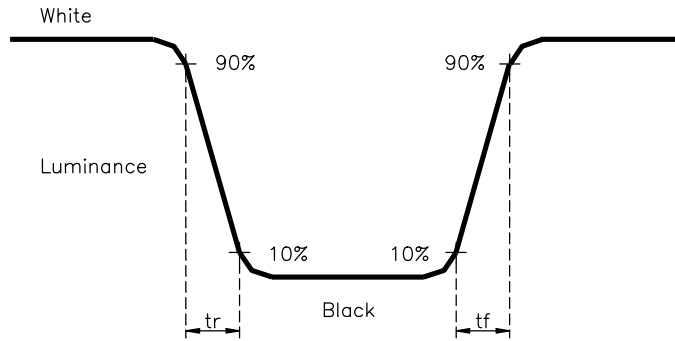

(7) Definition of Cross talk Modulation Ratio

$$CTR = \text{MAX}(|(Lb1-La)/Lc| \times 100, |(Lb2-La)/Lc| \times 100)$$

La : Pattern A(Half-Tone pattern) Measure point Luminance

Lb1,Lb2 : Pattern B1、Pattern B2 Measure point Luminance

Lc : Pattern C(white pattern) Measure point Luminance

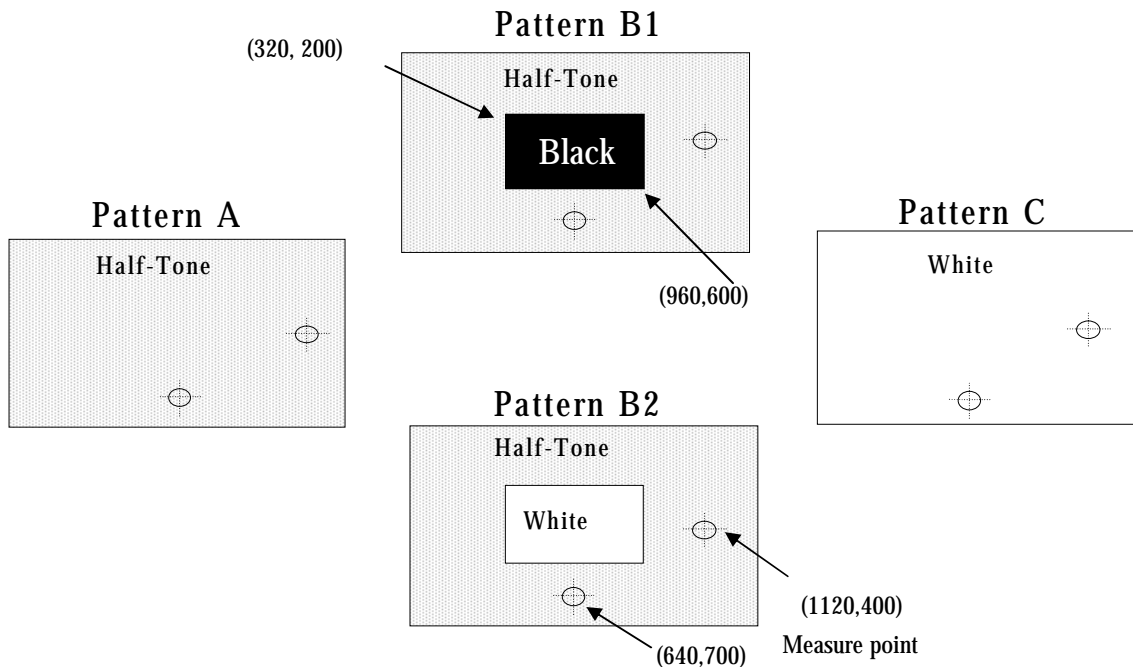

(8) Definition of Image Sticking

Continuously display the test pattern showing in the below figure for 3 hrs at 25°C.

Then switch to gray pattern, and the previous image should not persist more than 5 sec.

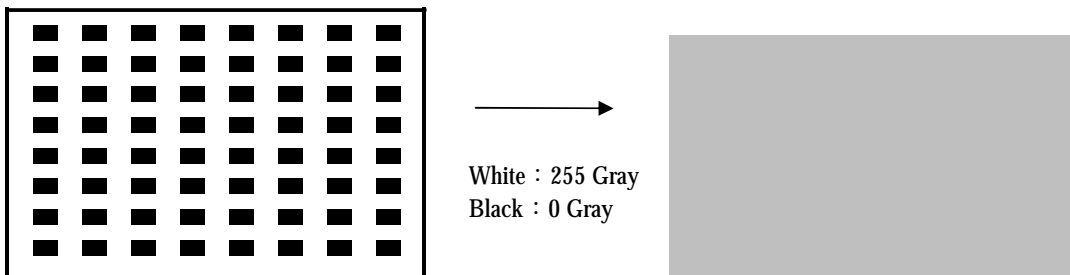

(9) Definition Gamma(VESA)

Based on Customer Sample, take the average value as a standard center value and the variation range of Gamma value caused by loop voltage error should be between +/- 0.2. the bellow figure shows how to obtain the gamma curve and  $\gamma$  (from gray level: 0、16、32----224、240、255).

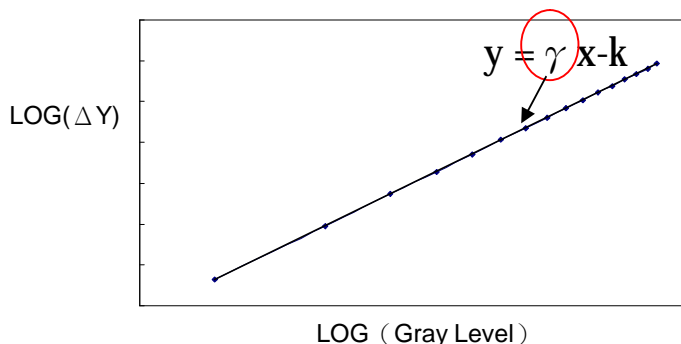

## 9.RELIABILITY TEST CONDITIONS

### (1)Temperature and Humidity

TEST ITEMS	CONDITIONS
HIGH TEMPERATURE OPERATION	50°C,48h
HIGH TEMPERATURE STORAGE	65°C,48h
LOW TEMPERATURE OPERATION	0°C,48h
LOW TEMPERATURE STORAGE	-30°C,48h
HIGH TEMPERATURE HIGH HUMIDITY OPERATION	45° C , 90%RH ,48h
HIGH TEMPERATURE HIGH HUMIDITY STORAGE	50°C , 90%RH(Max), 48h
THERMAL SHOCK(No operation)	BETWEEN -30°C (25h)AND 65°C (2h),12 CYCLES (Variation of temperature : under10°C/min)

### (2) Shock & Vibration

ITEMS	CONDITIONS
SHOCK (OPERATION)	<ul style="list-style-type: none"> <li>  Shock level: 120G</li> <li>  Waveform: half sinusoidal wave, 3ms</li> <li>  Number of shocks: one shock input in each direction of three mutually perpendicular axes for a total of six shock inputs.</li> </ul>
SHOCK (NON-OPERATION)	<ul style="list-style-type: none"> <li>  Shock level: 210G</li> <li>  Waveform: half sinusoidal wave, 3ms</li> <li>  Number of shocks: one shock input in each direction of three mutually perpendicular axes for a total of six shock inputs.</li> </ul>
VIBRATION (OPERATION)	<ul style="list-style-type: none"> <li>  Vibration level: 1.1G , Random, perpendicular axis(each x,y,z axis): 20 min</li> <li>  5 to 50 Hz 0.024 G<sup>2</sup>/Hz</li> <li>  50 to 100 Hz -36dB/oct</li> <li>  Vibration level: 1.5G , sinusoidal wave, perpendicular axis(each x,y,z axis): 20 min</li> <li>  5 to 50 Hz 9Hz/min</li> </ul>
VIBRATION (NON-OPERATION)	<ul style="list-style-type: none"> <li>  Vibration level: 1.1G , Random, perpendicular axis(each x,y,z axis): 20 min</li> <li>  5 to 50 Hz 0.11 G<sup>2</sup>/Hz</li> <li>  50 to 100 Hz -36dB/oct</li> <li>  Vibration level: 2.5G , sinusoidal wave, perpendicular axis(each x,y,z axis): 20 min</li> <li>  5 to 50 Hz 9Hz/min</li> </ul>

### (3) ESD Test

ITEMS	CONDITIONS
ESD (OPERATION)	<ul style="list-style-type: none"> <li>  Air mode : ICE 1000-4-2 15KV</li> </ul>
ESD (NON-OPERATION)	<ul style="list-style-type: none"> <li>  Contact mode : 200pF, 0Ω, ±250V to I/F connector pins</li> </ul>

NOTE:test position (1)LCD glass and metal bezel  
(2)I/F connector pins

## (4) Pressure Test

ITEMS	CONDITIONS
Pressure	<ul style="list-style-type: none"> <li>┆ Loading form :ψ 15nm</li> <li>┆ 15 kgf 5 sec</li> </ul>

## (5) Height Test

ITEMS	CONDITIONS
Height (Slight Pressure) (OPERATION)	┆ 700hPa(3000m),48hr
Height (Slight Pressure) (NON-OPERATION)	┆ 260hPa(10000m),48hr

## (6) Judgment standard

The judgment of the above test should be made as follow:

Pass: Normal display image with no obvious non-uniformity and no line defect. Partial transformation of the module parts should be ignored.

Fail: No display image, obvious non-uniformity, or line defects.

## 10. HANDLING PRECAUTIONS FOR TFT-LCD MODULE

Please pay attention to the followings in handling- TFT-LCD products.

### 10.1 ASSEMBLY PRECAUTION

- (1) Please use the mounting hole on the module side in installing and do not beading or wrenching LCD in assembling. And please do not drop, bend or twist LCD module in handling.
- (2) Please design display housing in accordance with the following guidelines.
  - Housing case must be destined carefully so as not to put stresses on LCD all sides and not to wrench module. The stresses may cause non-uniformity even if there is no non-uniformity statically.
  - Keep sufficient clearance between LCD module back surface and housing when the LCD module is mounted. Approximately 1.0 mm of the clearance in the design is recommended taking into account the tolerance of LCD module thickness and mounting structure height on the housing.
  - When some parts, such as, FPC cable and ferrite plate, are installed underneath the LCD module, still sufficient clearance is required, such as 0.5mm. This clearance is, especially, to be reconsidered when the additional parts are implemented for EMI countermeasure.
  - Design the inverter location and connector position carefully so as not to give stress to lamp cable, or not to interface the LCD module by the lamp cable.
  - Keep sufficient clearance between LCD module and the others parts, such as inverter and speaker so as not to interface the LCD module. Approximately 1.0mm of the clearance in the design is recommended.
- (3) Please do not push or scratch LCD panel surface with any-thing hard. And do not soil LCD panel surface by touching with bare hands. (Polarizer film, surface of LCD panel is easy to be flawed.)
- (4) Please do not press any parts on the rear side such as source TCP, gate TCP, control circuit board and FPCs during handling LCD module. If pressing rear part is unavoidable, handle the LCD module with care not to damage them.
- (5) Please wipe out LCD panel surface with absorbent cotton or soft clothe in case of it being soiled.
- (6) Please wipe out drops of adhesives like saliva and water on LCD panel surface immediately. They might damage to cause panel surface variation and color change.
- (7) Please do not take a LCD module to pieces and reconstruct it. Resolving and reconstructing modules may cause them not to work well.
- (8) Please do not touch metal frames with bare hands and soiled gloves. A color change of the metal frames can happen during a long preservation of soiled LCD modules.
- (9) Please pay attention to handling lead wire of backlight so that it is not tugged in connecting with inverter.

### 10.2 OPERATING PRECAUTIONS

- (1) Please be sure to turn off the power supply before connecting and disconnecting signal input cable.
- (2) Please do not change variable resistance settings in LCD module. They are adjusted to the most suitable value. If they are changed, it might happen LCD does not satisfy the characteristics specification.
- (3) Please consider that LCD backlight takes longer time to become stable of radiation characteristics in low temperature than in room temperature.
- (4) A condensation might happen on the surface and inside of LCD module in case of sudden change of ambient temperature.
- (5) Please pay attention to displaying the same pattern for very long time. Image might stick on LCD. If then, time going on can make LCD work well.
- (6) Please obey the same caution descriptions as ones that need to pay attention to ordinary electronic parts.

### 10.3 PRECAUTIONS WITH ELECTROSTATICS

- (1) This LCD module use CMOS-IC on circuit board and TFT-LCD panel, and so it is easy to be affected by electrostatics. Please be careful with electrostatics by the way of your body connecting to the ground and so on.
- (2) Please remove protection film very slowly on the surface of LCD module to prevent from

electrostatics occurrence.

#### 10.4 STORAGE PRECAUTIONS

- (1) When you store LCDs for a long time, it is recommended to keep the temperature between 0°C ~40°C without the exposure of sunlight and to keep the humidity less than 90%RH.
- (2) Please do not leave the LCDs in the environment of high humidity and high temperature such as 60°C 90%RH.
- (3) Please do not leave the LCDs in the environment of low temperature; below -20°C.

#### 10.5 SAFETY PRECAUTIONS

- (1) When you waste LCDs, it is recommended to crush damaged or unnecessary LCDs into pieces and wash them off with solvents such as acetone and ethanol, which should later be burned.
- (2) If any liquid leaks out of a damaged-glass cell and comes in contact with the hands, wash off thoroughly with soap and water.

#### 10.6 OTHERS

- (1) A strong incident light into LCD panel might cause display characteristics' changing inferior because of polarizer film, color filter, and other materials becoming inferior. Please do not expose LCD module direct sunlight and strong UV rays.
- (2) Please pay attention to a panel side of LCD module not to contact with other materials in preserving it alone.
- (3) For the packaging box, please pay attention to the followings:
  - Packaging box and inner case for LCD are designed to protect the LCDs from the damage or scratching during transportation. Please do not open except picking LCDs up from the box.
  - Please do not pile them up more than 3 boxes. (They are not designed so.) And please do not turn over.
  - Please handle packaging box with care not to give them sudden shock and vibrations. And also please do not throw them up.
  - Packing box and inner case for LCDs are made of cardboard. So please pay attention not to get them wet. (Such like keeping them in high humidity or wet place can occur getting them wet.)

### 11. PACKING FORM

- 1 Package quantity in one carton: 10 pieces.
- 1 Carton size:485(L)×365(W)×365(H) (unit : mm)
- 1 For domestic transportation only.

### 12. SAFETY

1. UL 60950-1, 2003, First Edition, Underwriters Laboratories. Standard Safety of Information Technology Equipment, Including Electrical Business Equipment.
2. CAN/ CSA C22.2 No. 60950-1-03 First Edition, Canadian Standards Association, April 1, 2003. Standard Safety of Information Technology Equipment, Including Electrical Business Equipment.
3. We will try our best comply the directive 2002/95/EC of the European, and that we will do our possible not to use or use exceeding the limits of banned substances. We also comply with product-related environmental laws and regulations in manufacturing process and do our best to achieve global environmental protection standards.