

mass integrated

global part distribution • product lifecycle partner
excess inventory management • value-ad service provider



Data sheet provided by Mass Integrated

massintegrated.com • displayalliance.com

Please call +1.978.465.6190
Email: sales@massintegrated.com



ISO 9001: 2008

Mass Integrated complies with all DMCA takedown notices. Please send a formal DMCA Takedown Notice to Mass Integrated Systems, Inc. • 18 Henry Graf Jr. Road, Unit 1 • Newburyport, MA 01950.

Data Sheet

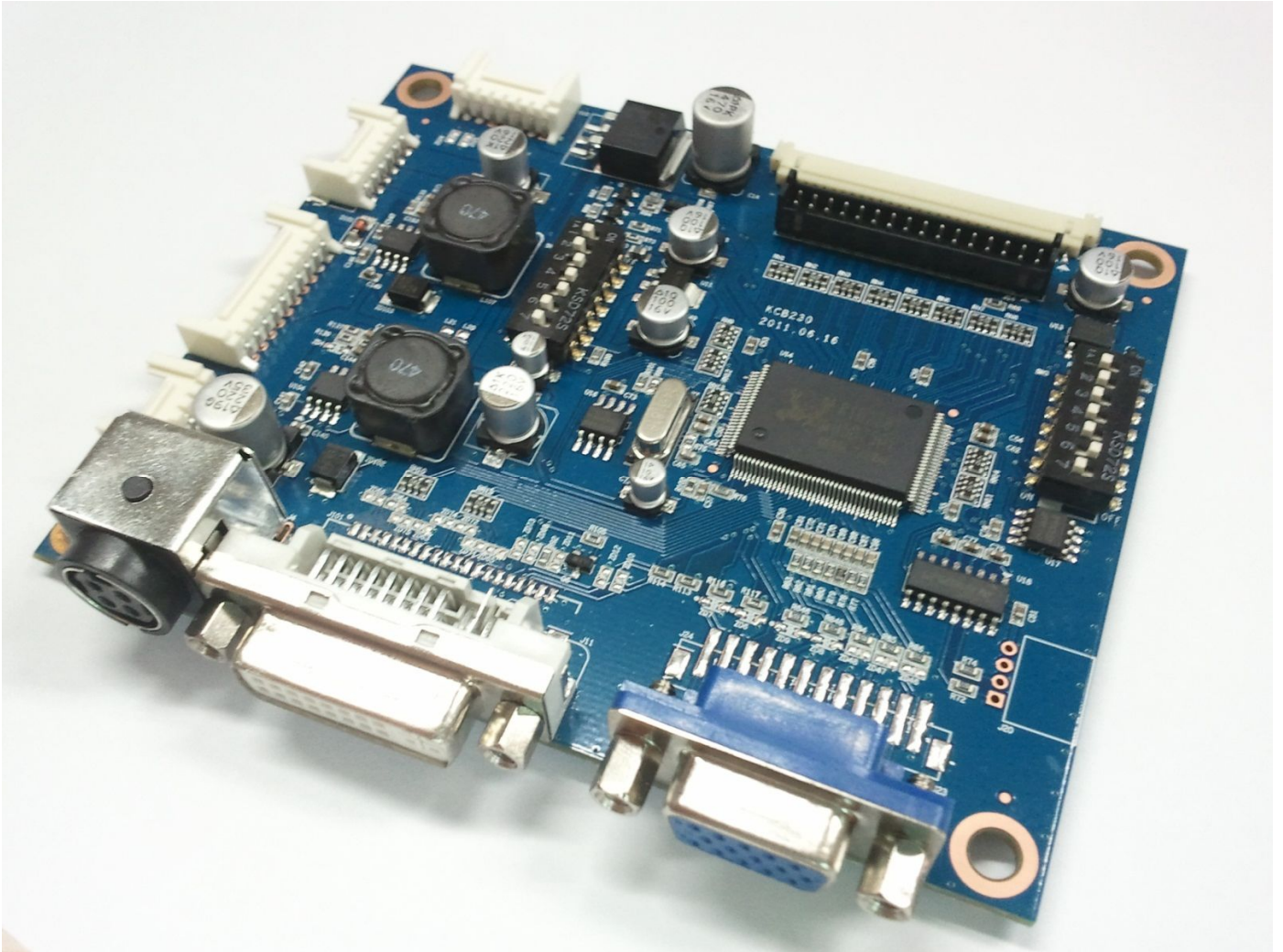

TFT LCD Controller Board

KCB230(RoHS Compliant)

Jul, 2011

Rev. 0.0

CONTENTS

- INTRODUCTION..... 4
- GENERAL SPECIFICATION..... 5
- ABSOLUTE MAXIMUM RATINGS..... 5
- RELIABILITY-ENVIRONMENTAL TEST CONDITION..... 6
- ELECTRICAL SPECIFICATION..... 7
- SYSTEM DESIGN..... 8
- BLOCK DIAGRAM..... 9
- ASSEMBLY NOTES..... 10
- CONNECTION & OPERATION..... 11
- OSD CONTROL BOARD..... 12
- OSD FUNCTION..... 13
- IR CONTROL..... 15
- CONNECTOR, PINOUT & JUMPER..... 16
- CONTROLLER DIMENSIONS 23
- APPLICATION NOTES..... 24
- TROUBLESHOOTING..... 25
- APPLICABLE GRAPHIC MODE..... 26
- ACCESSORY..... 26

Revision History

No	Description	Date	Rev.	Page
1	Preliminary Release	Jul. 7, 11	0.0	

INTRODUCTION

Designed for LCD monitor and other flat panel display application the controller provides an auto-input synchronization and easy to use interface controller for:

- TFT (active matrix) LCD panels of 800x600, 1024x768, 1280x768, 1366x768, 1280x1024, 1440x900, 1680x1050, 1600x1200, 1920x1080 and 1920x1200 resolutions.
- Computer Analog/Digital Video signals of VGA, SVGA, XGA, WXGA, SXGA WXGA+, WSXGA+, UXGA, and WUXGA standard.
- All VESA Standard Signal Input Support.

HOW TO PROCEED

- Ensure that you have all parts & they are correct, refer to:
 - Connection diagram
 - Connector reference
 - Assembly notes
- Check controller switch & jumper settings (errors may damage the panel)
- Prepare the PC
- Connect the parts
- Understand the operation & functions

IMPORTANT USAGE NOTE

This equipment is for use by developers and integrators. The manufacturer accepts no liability for damage or injury caused by the use of this product. It is the responsibility of the developer, integrators or other users of this product to:

- Ensure that all necessary and appropriate safety measures are taken.
- Obtain suitable regulatory approvals as may be required.
- Check power settings to all component parts before connection.

DISCLAIMER

There is no implied or expressed warranty regarding this material.

GENERAL SPECIFICATION

No.	Item	Description			
1	Supported Resolution	Panel Resolution	Resolution		
		XGA Panel	1024X768		
		WXGA Panel	1280X768		
		WXGA Panel	1366X768		
		SXGA Panel	1280X1024		
		WSXGA+ Panel	1680X1050		
		UXGA Panel	1600X1200		
		HD Panel	1920X1080		
		WUXGA Panel	1920X1200		
2	LCD Module	SVGA, XGA, WXGA, SXGA, WSXGA+, UXGA, HD, WUXGA			
3	Signal Input	Analog RGB, TMDS(DVI)			
4	Resolution Support	H: 31 ~ 80kHz			
		V: 55 ~ 76Hz			
5	OSD Control	Menu, Sel, Up, Down, Power		5 keys	
	Plug & Play	VESA DDC 2B Ver1.3			
6	Power Connector	Input	Type: IEC320 MALE 3Line Connector		
7	Power Consumption	Supply Voltage	12Vdc/15Vdc/18Vdc or 24Vdc		
		Max Power	10W (Without Back Light Inverter, LCD Panel)		
8	Signal Connector	Analog	DSUB 15P(R, G, B Separate H, V Sync)		
		Digital	DVI-D(TMDS)		TMDS

ABSOLUTE MAXIMUM RATINGS

Parameter	Symbol	Values		Units	Notes
		Min	Max		
Operating Temperature	T _{OP}	0	50	°C	
Storage Temperature	T _{ST}	-20	60	°C	
Operating Ambient Humidity	H _{OP}	10	90	%RH	
Storage Humidity	H _{ST}	10	90	%RH	

* Note: No condensation of water

RELIABILITY-ENVIRONMENTAL TEST CONDITION

Item	Condition	Method
Vibration (non-operating)	Wave form : random Vibration level : 1.0G RMS Bandwidth : 10-500Hz Duration : X,Y,Z, 10 min	One time each direction
Shock (non-operating)	Shock level : 100G Waveform : half sine wave, 2ms Direction : $\pm X, \pm Y, \pm Z$	One time each direction

*** Note: Tested with Mechanical part like as metal frame or plastic housing.**

ELECTRICAL SPECIFICATION

Input characteristic

Description	Signal	Unit	Min	Typical	Max	Remarks
Power In (24V)						
	Input	Vdc	22.8	24.0	25.2	
Power In (18V)						
	Input	Vdc	17.0	18.0	19.0	
Power In (12V)						
	Input	Vdc	11.4	12.0	12.6	
RGB Input						
	Analog RGB	Vp-p	0	0.7	-	
	Sync	Vdc	0	5.0	5.5	
	H Frequency	KHz	31	64	80	Depends on Mode
	V Frequency	Hz	55	60	75	Depends on Mode
DVI Input						
	TMDS	mVp-p	450	500	900	

Output Characteristics

	Signal	Unit	Min	Typical	Max	Remarks
Panel Power						
	LCD Power (18V)	Vdc	17.0	18	19.0	Jumper option
	LCD Power (12V)	Vdc	11.4	12	12.6	Jumper option
	LCD Power(5V)	Vdc	4.75	5	5.25	Jumper option
	LCD Power(3.3V)	Vdc	3.13	3.3	3.46	Jumper option
LVDS Interface						
	Differential output	mVp-p	250	350	450	Different +/-
Inverter Interface						
	Power out	Vdc	22.8 11.4	24 12	25.2 12.6	Depends on Power Input and Spec.
	On/Off control	V	0		3.3	
	Brightness control	V	3.3		0	Option
			0		3.3	Option
		Step		0		100

Power Consumption

	Input Power	Unit	Min *1	Typical	Max	Remarks
Board without Panel and Inverter						
	LCD Power (24V)	Watts	0.51	2.22	-	*2
		A	0.02	0.09		
	LCD Power (12V)	Watts	0.62	2.05	-	*2
		A	0.05	0.17		

*1: Power saving mode

* 2: Controller board only, disconnected with LCD and Inverter.

System power consumption should be different value with different type of LCD and Inverter.

BLOCK DIAGRAM

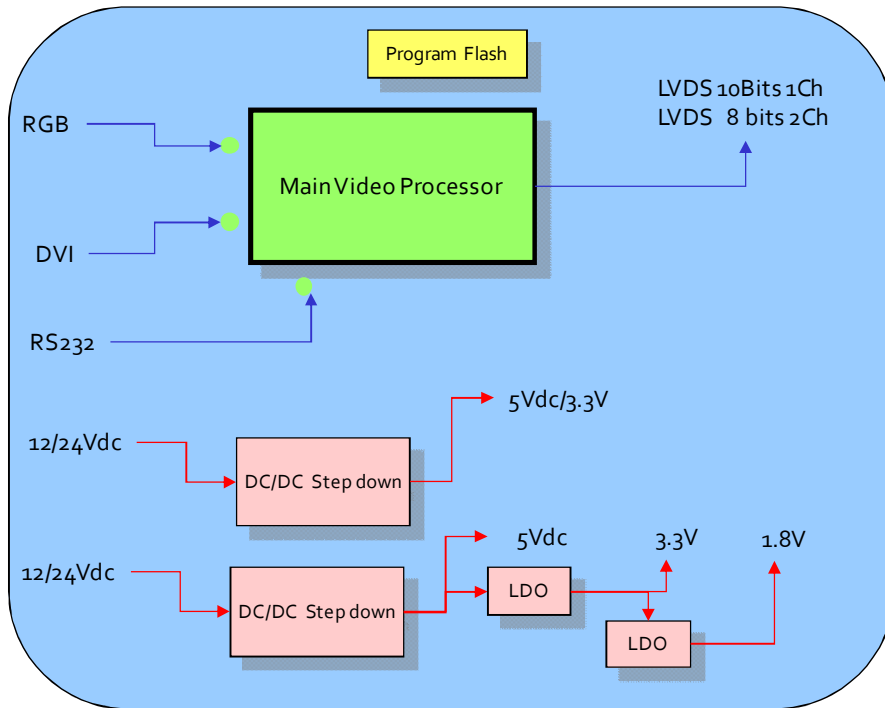

ASSEMBLY NOTES

This controller is designed for monitors and custom display projects using TFT (active matrix) LCD panels of 1024x768, 1280x768, 1366x768, 1280x1024, 1680x1050, 1600x1200, 1920x1080 and 1920x1200 resolutions, VGA, SVGA, XGA, WXGA, SXGA, WSXGA+, UXGA, WUXGA, HD and FHD signal input. The following provides some guidelines for installation and preparation of a finished display solution.

Preparation: Before proceeding it is important to familiarize yourself with the parts making up the system and the various connectors, mounting holes and general layout of the controller. As much as possible connectors have been labeled. Guides to connectors and mounting holes are shown in the following relevant sections.

- 1. LCD Panel:** This controller has LVDS interface logic on the Board for different kind of TFT LCD panel.
- 2. Controller:** Handle the controller with care as static charge may damage electronic components, Make sure correct jumper and switches settings to match the target LCD and PDP panel
- 3. LCD connector board:** Different makers and models of LCD panel require different panel signal connectors and different pin assignments.
- 4. LVDS signal cables:** In order to provide a clean signal it is recommended that LVDS signal cables should not longer than 30cm. If loose wire cabling is utilized these can be made into a harness with cable ties. Care should be taken when you place the cables to avoid signal interface. Additionally it may necessary in some systems to add ferrite cores to the cables to minimize signal noise.
- 5. Inverter:** This will be required for the backlight of an LCD, some LCD panel have an inverter built in. As LCD panels may have 1 or more backlight tubes and the power requirements for different panel backlights may vary it is important to match the inverter in order to obtain optimum performance. See application notes for more information on connection.
- 6. Inverter cable:** Different inverter models require different cables and different pin assignment. Make sure the correct cable pin out to match the inverter. Unsuitable cable pins out may damage the inverter.
- 7. OSD Button:** See Operational Function section.
- 8. LED Indicator:** This LED shows the state of controller.
 - Green – Normal state
 - Red – Off mode
 - Amber – DPMS mode
- 9. Power switch:** This switch is located on OSD button board.
- 10. Power input:** Proper power is required to supply power for the controller, the Inverter and the LCD panel
- 11. VGA Input Cable:** As this may affect regulatory emission test result, a suitably shielded cable should be utilized.

Installation Notes

EMI:

Shielding will be required for passing certain regulatory radiation tests. Also the choice of video board and power supply can affect the test result.

Consideration should be given to:

- Electrical insulation.
- Grounding.
- EMI shielding.
- Heat & ventilation

Caution:

Ensure that the adequate insulation is provided for all areas of the PCB with special attention to high voltage parts such as the inverter.

Remarks:

For a specific panel use, one panel sample and full technical specifications for the LCD panel from the manufacturer are required to test for tuning up screen image. We can provide engineering service for customer's specific controller development.

Setup Notes

Once the circuit has been connected, a setup procedure for optimal is requires a few minutes. The following instructions are likely to form the basis of the finished product operation manual.

PC Settings:

The PC needs to be set to an appropriate graphics mode that has the same resolution with the LCD panel to have clear screen image. And the vertical refresh rate should be set to one of 56~75Hz, non – interlaced signal.

Display System Settings

The OSD (On Screen Display) provides certain functions to have clear image and others. This board supports 5 buttons OSD operation as a standard. The control functions defined on OSD operation are as below.

PC Graphics Output:

- Signal quality is very important, if there is noise or instability in the PC graphics output this may result in visible noise on the display
- Refer to the graphic modes table in specification section for supported modes.
- Non-interlaced & interlaced video input is acceptable.

Important: please read the application notes section for more information.

CONNECTION & OPERATION

CAUTION:

Never connect or disconnect parts of the display system when the system is operating as this may cause serious damage.

CONNECTION:

1. **LCD panel & Inverter:** Connect the inverter (if it is not built- in the panel) to the CCFT lead connector of the LCD panel.
2. **LVDS type panels:** Plug the signal cables direct to J23(or J24) of the controller for 1 or 2 channel interface panel
3. **Inverter & Controller:** Plug the inverter cable to J1 of the controller and another end to the connector on the inverter.
4. **Function switch & Controller:** Plug the OSD switch mount cable to J26(or J27) of the controller and another end to the OSD board.
5. **Jumpers:** Check all jumpers are set correctly. Details referring the jumpers setting table (in the following section)
6. **VGA cable & Controller:** Plug the VGA cable to the connector J15 of the controller.
7. **DIV-D Cable & Controller:** Plug the DVI-D Cable to the connector J18 of the controller.
8. **Power supply to Controller:** Plug the DC 12V/ power in to the connector J10 of the controller.
9. **SMPS & Controller :** Plug the SMPS power in to the connector J12 of the controller
10. **Power on:** Switch on the controller and panel by using the OSD switch mount.

General:

- If you use supplied cables & accessories, ensure that they are correct for the model of the panel and the controller.
- If you make your own cables & connectors, refer carefully to both the panel & inverter specifications and the section in this manual, "Connectors, Pin outs & Jumpers" to ensure the correct pin to pin wiring.

PC Setting:

The controller has been designed to take a very wide range of input signals however to optimize the PC's graphic performance we recommend choosing 60Hz vertical refresh rate – this will not cause screen flicker.

OSD CONTROL BOARD

The OSD (On Screen Display) provides certain functions to have clear image and others. This board supports 5 buttons OSD operation as a standard. The control functions defined on OSD operation are as below. (unit: mm)

Appearance

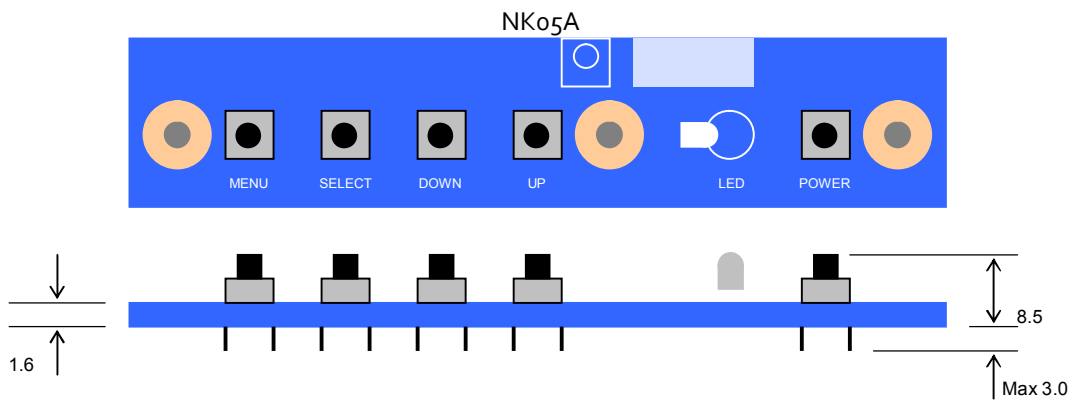

Button	Function	Status	HOT Key
LED	Indicates operation status	Green : Normal State Red : Off Mode Amber : DPMS Mode	
POWER	Power on/off		
MENU	Enable MENU Window Disable MENU Window Exit from Sub function		
SELECT	Select function		No OSD Window, Input Source Change
DOWN	Move to Down or Left		No OSD Window, Auto Color
UP	Move to Up or Right		No OSD Window, Auto Configuration

OSD FUNCTION

The chosen OSD settings will be stored in memory. The OSD menu can be cleared from the screen by pressing the **MENU** button otherwise it will be automatically cleared after a few second of non-use.

OSD MAIN MENU

[PICTURE]

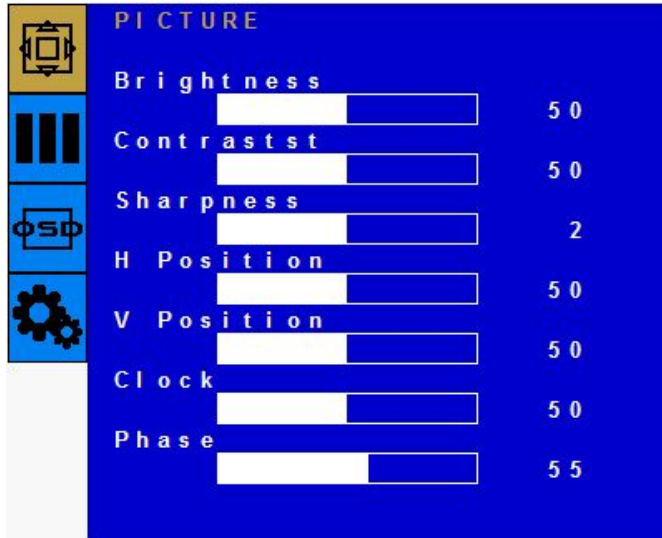

PICTURE

- Brightness 50
- Contrast 50
- Sharpness 2
- H Position 50
- V Position 50
- Clock 50
- Phase 55

[COLOR]



COLOR

- Color Status Management
 - User
- Red 50
- Green 50
- Blue 50
- Auto Color
 - To Start

[OSD]

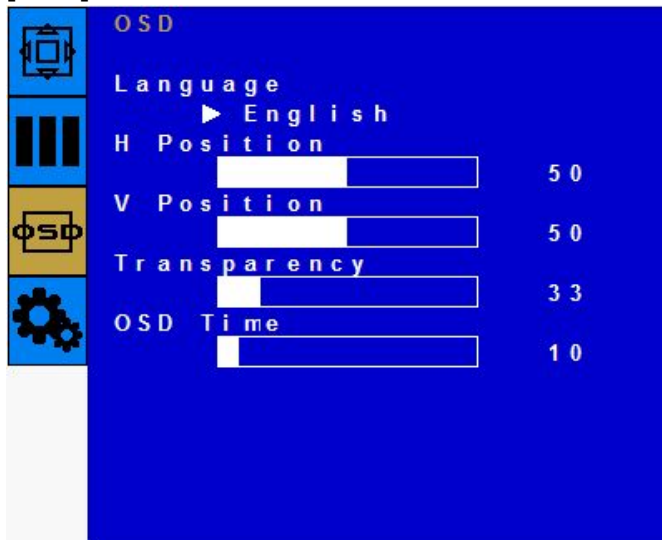

OSD

- Language
 - English
- H Position 50
- V Position 50
- Transparency 33
- OSD Time 10

[SETUP]



SETUP

- Source
 - RGB
- Factory Reset
 - To Start
- Aspect
 - Off
- Set ID
 - Off

1280x1024 60Hz

OSD GUI Control Table

MAIN MENU	SUB MENU	CONTROL	
Picture	Brightness	50(0~100)	
	Contrast	50(0~100)	
	Sharpness	2(0~4)	
	H Position	50(0~100)	PC ONLY
	V Position	50(0~100)	
	Clock	50(0~100)	
	Phase	30(0~100)	
Color	Color Status Management	User(User, Warm, Normal, Cool)	
	Red	50(0~100)	PC ONLY
	Green	50(0~100)	
	Blue	50(0~100)	
	Auto Color	To Start	
OSD	Language	English(English, Deutsh, Francais, Italiano, Espanol, Korean)	
	H Position	50(0~100)	
	V Position	50(0~100)	
	Transparency	33(0~100)	
	OSD Time	10(3~30)	
SETUP	Source	RGB, DVI, AUTO	
	Factory reset	To Start	
	Aspect	Off(On/Off)	
	Set ID	Off(On/Off)	

IR Control

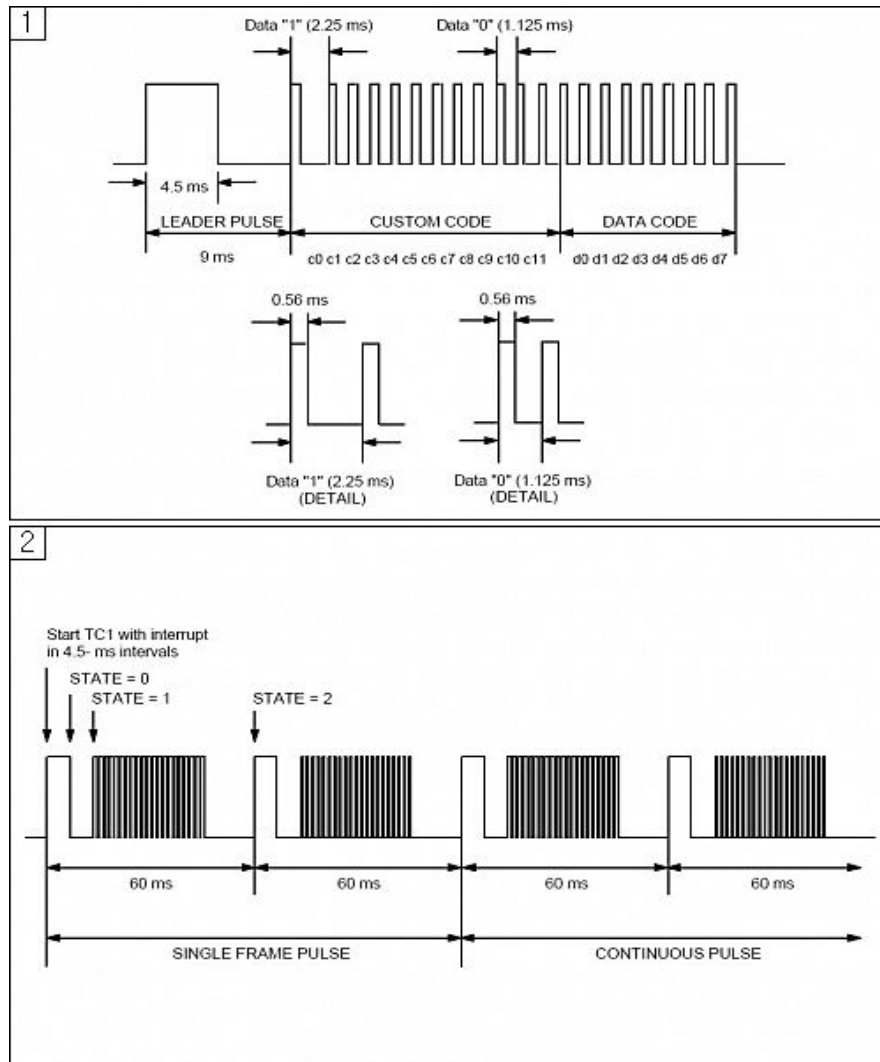

Custom Code : 0x40

Data Code

Function	Date Code
POWER	0x00
MENU	0x11
SELECT	0x04
DOWN	0x06
UP	0x02
LEFT	0x03
RIGHT	0x05
VOL_DOWN	0x0B
VOL_UP	0x08
MUTE	0x0C

CONNECTOR, PINOUT & JUMPERS

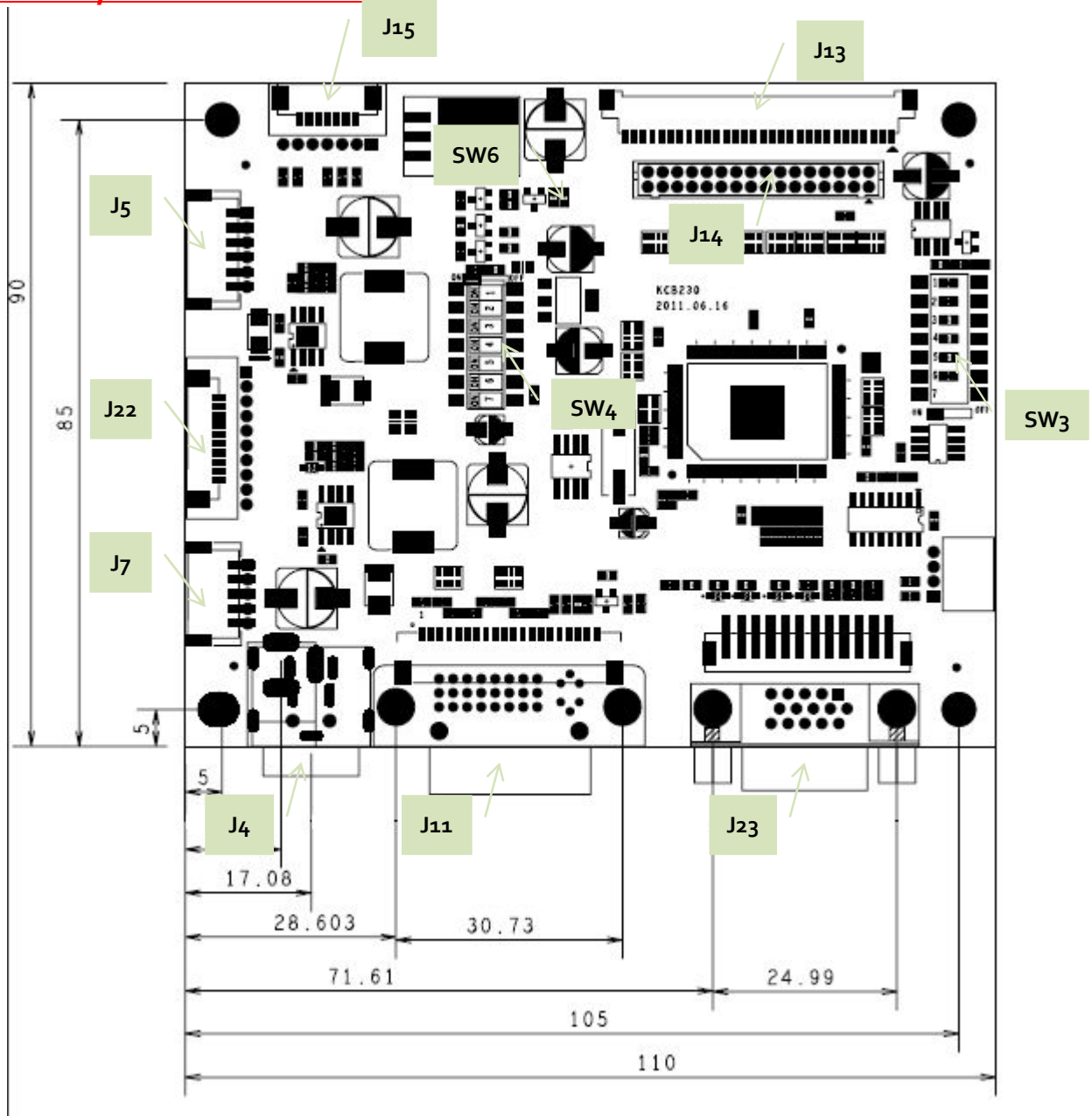

Summary

Reference	Item	Description	Type	Manufacture
J7	Connector	Internal 12V or 24V Power Input	SMAW200-04	YEONHO
J22	Connector	Backlight Inverter Connector	SMAW200-10	YEONHO
J5	Connector	5V/12V Power output	SMAW200-06	YEONHO
J4	Jack	24V Input Dc power Jack	KPJ-4S-S	-
J11	Connector	DVI-D Input(TMD5) Connector	DVI-D24P	-
J23	Connector	Analog RGB Input Connector	15P D-SUB	-
J13	Connector	LCD Interface connector(2Ch LVDS)	12507WR-30	YEONHO
J14	Connector	LCD Interface connector(2Ch LVDS)	YDW200-32	YEONHO
J15	Connector	OSD Board Connector	SMAW200-07	YEONHO
SW3	Switch	Panel Type Select Switch	KSD72S	OTAX
SW4	Switch	Panel Power Select Switch Backlight Inverter Option Switch	KSD42S	OTAX

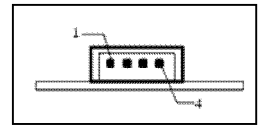

J7 : 12V / 24 Power Input

Pin No.	Symbol	Description
1	Vcc	+12V / +24V
2	Vcc	+12V / +24V
3	GND	Ground
4	GND	Ground

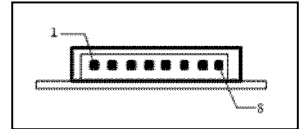

J5 : Backlight Inverter connector

Pin No.	Symbol	Description
1, 2	Vcc	+12V
3, 4	GND	Ground
5, 6	Vcc	+5V

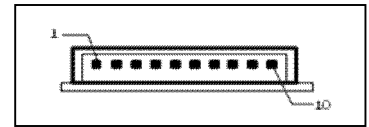

J22 : Backlight Inverter connector

Pin No.	Symbol	Description
1	DIM-ADJ	DIM-adjustment analog dimming control signal * make sure inverter specification
2	ON/OFF	Inverter digital ON(3.3V)/OFF(0V) signal
3,4,5,6	GND	Ground
7,8,9,10	B+	B+(24V or 12V)

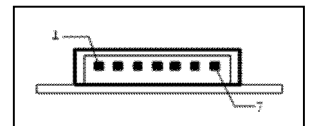

J15 : OSD Board connector

Pin No.	Symbol	Description
1	Vcc	+5V power for IR sensor
2	IRQ	Infrared rays signal line.
3	LED1	Green LED
4	LED2	Red LED
5	GND	Ground
6	ADC-IN0	Menu, Up
7	ADC-IN1	Power, Down, Up

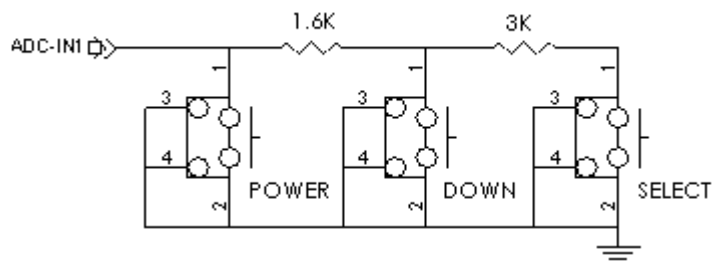
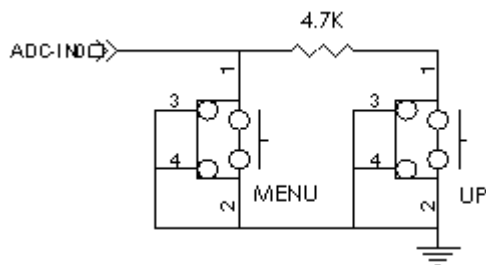



J4 : 12V Power Input Jack(Optional)

Pin No.	Symbol	Description
-	GND	Ground
+	Vcc	12V

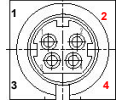

J4 : +24V Power Input Jack

Pin No.	Symbol	Description
1,3	GND	Ground
2,4	Vcc	24V

EX) LSE0227B24130(4PIN) Li-shin Adapter / SLS0227B24118

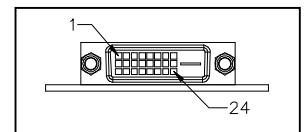

J11 : DVI-D Input(TMDS) Connector

Pin No.	Symbol	Description
1	TMDS DATA2-	TMDS DATA2 Differential Negative Signal
2	TMDS DATA2+	TMDS DATA2 Differential Positive Signal
3	TMDS DATA2 Shield	Shield for TMDS Channel #2
4	NC	No Connection
5	NC	No Connection
6	DDC Clock	The Data Line for the DDC Interface
7	DDC Data	The Clock Line for the DDC Interface
8	NC	No Connection
9	TMDS DATA1-	TMDS DATA1 Differential Negative Signal
10	TMDS DATA1+	TMDS DATA1 Differential Positive Signal
11	TMDS DATA1 Shield	Shield for TMDS Channel #1
12	NC	No Connection
13	NC	No Connection
14	+5V Power	+5 Volt signal for EDID (Un-powered Monitor)
15	GND(for +5V)	Ground for +5 Volt Power pin, Sync return
16	HPD	Identify the presence of a monitor
17	TMDS DATA0-	TMDS DATA0 Differential Negative Signal
18	TMDS DATA0+	TMDS DATA0 Differential Positive Signal
19	TMDS DATA0 Shield	Shield for TMDS Channel #0
20	NC	No Connection
21	NC	No Connection
22	TMDS CLOCK Shield	Shield for TMDS Clock differential Pair
23	TMDS CLOCK+	TMDS DATA0 Differential Positive Signal
24	TMDS CLOCK-	TMDS DATA0 Differential Negative Signal

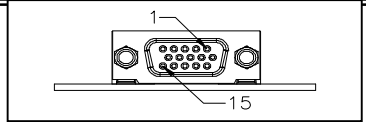

J23 : Analog RGB Input Connector

Pin No.	Symbol	Description
1	Red1	Red analog input
2	Green1	Green analog input
3	Blue1	Blue analog input
4	GND	Ground
5	GND	Ground
6	GND	Ground
7	GND	Ground
8	GND	Ground
9	NC	Not connected
10	GND	Ground
11	GND	Ground
12	DSDA	DDC-SDA
13	HSYNC	Horizontal Sync
14	VSYNC	Vertical Sync
15	DSCL	Serial Clock Input

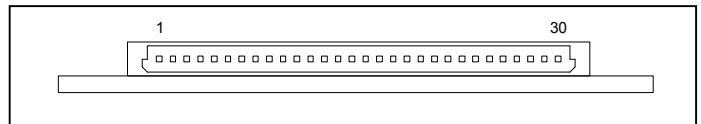

J13 : LCD Interface connector(2Ch LVDS)

Pin No.	Symbol	Description
1	MOD_PWR	Panel Power (12V, 5V or 3.3V)
2	MOD_PWR	Panel Power (12V, 5V or 3.3V)
3	MOD_PWR	Panel Power (12V, 5V or 3.3V)
4	MOD_PWR	Panel Power (12V, 5V or 3.3V)
5	GND	Ground
6	Option	High/Low for LCD Option
7	GND	Ground
8	Y3P-EVEN	Positive (+) LVDS differential first 3 data
9	Y3N- EVEN	Negative (-) LVDS differential first 3 data
10	YCP- EVEN	Positive (+) LVDS differential first Clock
11	YCN- EVEN	Negative (-) LVDS differential first Clock
12	Y2P- EVEN	Positive (+) LVDS differential first 2 data
13	Y2N- EVEN	Negative (-) LVDS differential first 2 data
14	GND	Ground
15	Y1P- EVEN	Positive (+) LVDS differential first 1 data
16	Y1N- EVEN	Negative (-) LVDS differential first 1 data
17	YoP- EVEN	Positive (+) LVDS differential first 0 data
18	YoN- EVEN	Negative (-) LVDS differential first 0 data
19	GND	Ground
20	Y3P-ODD	Positive (+) LVDS differential second 3 data
21	Y3N-ODD	Negative (-) LVDS differential second 3 data
22	YCP-ODD	Positive (+) LVDS differential second Clock
23	YCN-ODD	Negative (-) LVDS differential second Clock
24	Y2N-ODD	Positive(-) LVDS differential second 2 data
25	Y2P-ODD	Negative(+) LVDS differential second 2 data
26	GND	Ground
27	Y1P-ODD	Positive (+) LVDS differential second 1 data
28	Y1N-ODD	Negative(-) LVDS differential second 1 data
29	YoP-ODD	Positive (+) LVDS differential second 0 data
30	YoN-ODD	Negative (-) LVDS differential second 0 data

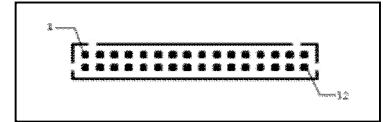

J14 : LCD Interface connector(8bit 2Ch LVDS)

Pin No.	Symbol	Description
1	MOD_PWR	Panel Power (12V, 5V or 3.3V)
2	MOD_PWR	Panel Power (12V, 5V or 3.3V)
3	MOD_PWR	Panel Power (12V, 5V or 3.3V)
4	Option	High/Low for LCD Option
5	GND	Ground
6	GND	Ground
7	Y3P-EVEN	Positive(+) LVDS differential first 4 data
8	Y3N- EVEN	Negative(-) LVDS differential first 4 data
9	YCP- EVEN	Positive (+) LVDS differential first 3 data
10	YCN- EVEN	Negative (-) LVDS differential first 3 data
11	Y2P- EVEN	Positive (+) LVDS differential first Clock
12	Y2N- EVEN	Negative (-) LVDS differential first Clock
13	Y1P- EVEN	Positive (+) LVDS differential first 2 data
14	Y1N- EVEN	Negative (-) LVDS differential first 2 data
15	YoP- EVEN	Positive (+) LVDS differential first 1 data
16	YoN- EVEN	Negative (-) LVDS differential first 1 data
17	Y3P-ODD	Positive (+) LVDS differential first 0 data
18	Y3N-ODD	Negative (-) LVDS differential first 0 data
19	GND	Ground
20	GND	Ground
21	YCP-ODD	Positive (+) LVDS differential second 4 data
22	YCN-ODD	Negative(-) LVDS differential second 4 data
23	Y2N-ODD	Positive (+) LVDS differential second 3 data
24	Y2P-ODD	Negative (-) LVDS differential second 3 data
25	Y1P-ODD	Positive (+) LVDS differential second Clock
26	Y1N-ODD	Negative (-) LVDS differential second Clock
27	YoP-ODD	Positive(-) LVDS differential second 2 data
28	YoN-ODD	Negative(+) LVDS differential second 2 data
29	NC	No Connection
30	NC	No Connection
31	NC	No Connection
32	NC	No Connection

SW3 : Target panel jumper setting

1: LVDS MAP Selection => ON : Map1 (Normal Type), OFF : Map2 (Shift Type)

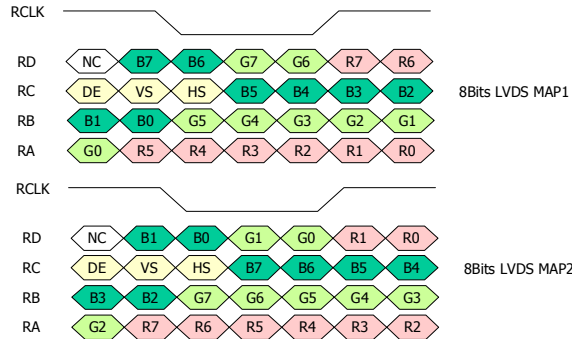
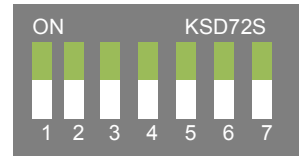

2~6 : Output Resolution Selection

2	3	4	5	6	Output	Remarks
OFF	ON	OFF	ON	ON	640X480	
OFF	OFF	OFF	OFF	OFF	800 X 600	
OFF	OFF	OFF	OFF	ON	1024 X 768	
OFF	OFF	OFF	ON	OFF	1280 X 768	
OFF	OFF	OFF	ON	ON	1280 X 1024	
OFF	OFF	ON	OFF	OFF	1366 X 768	
OFF	OFF	ON	OFF	ON	1400 X 1050	
OFF	OFF	ON	ON	OFF	1440 X 900	
OFF	OFF	ON	ON	ON	1600 X 1200	
OFF	ON	OFF	OFF	OFF	1680 X 1050	
OFF	ON	OFF	OFF	ON	1920 X 1080	
OFF	ON	OFF	ON	OFF	1920 X 1200	

7: Panel Option Selection

7	J13 Pin#6, J14 Pin#4 Output	Remarks
ON	Low(GND)	If #7 is On, J13 Pin#6 and J14 Pin#4 are Low
OFF	High(3.3V)	If #7 is Off, J13 Pin#6 and J14 Pin#4 are High

SW4 : Target LCD pane power jumper setting

1	2	3	Input Power	Output	Remarks
ON	OFF	OFF	24V	12V	
OFF	ON	OFF	12/24V	5V	
OFF	OFF	ON	12V/24V	3.3V	

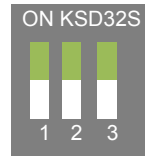

- Inverter Power : Same as Input power (12V/18V or 24V)

SW4 : Backlight Inverter Option setting

4	5	6	7	Dimming Voltage	Remarks
ON	ON	OFF	ON	0(Max), 5V(Min)	Analog
ON	OFF	ON	ON	0(Max), 3.3V(Min)	Analog
ON	ON	OFF	OFF	5V(Max), 0(Min)	Analog
ON	OFF	ON	OFF	3.3V(Max), 0(Min)	Analog
OFF	ON	OFF	ON	0(Max), 5V(Min)	PWM
OFF	OFF	ON	ON	0(Max), 3.3V(Min)	PWM
OFF	ON	OFF	OFF	5V(Max), 0(Min)	PWM
OFF	OFF	ON	OFF	3.3V(Max), 0(Min)	PWM

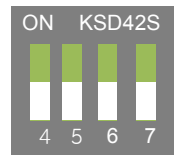

CONTROLLER DIMENSIONS

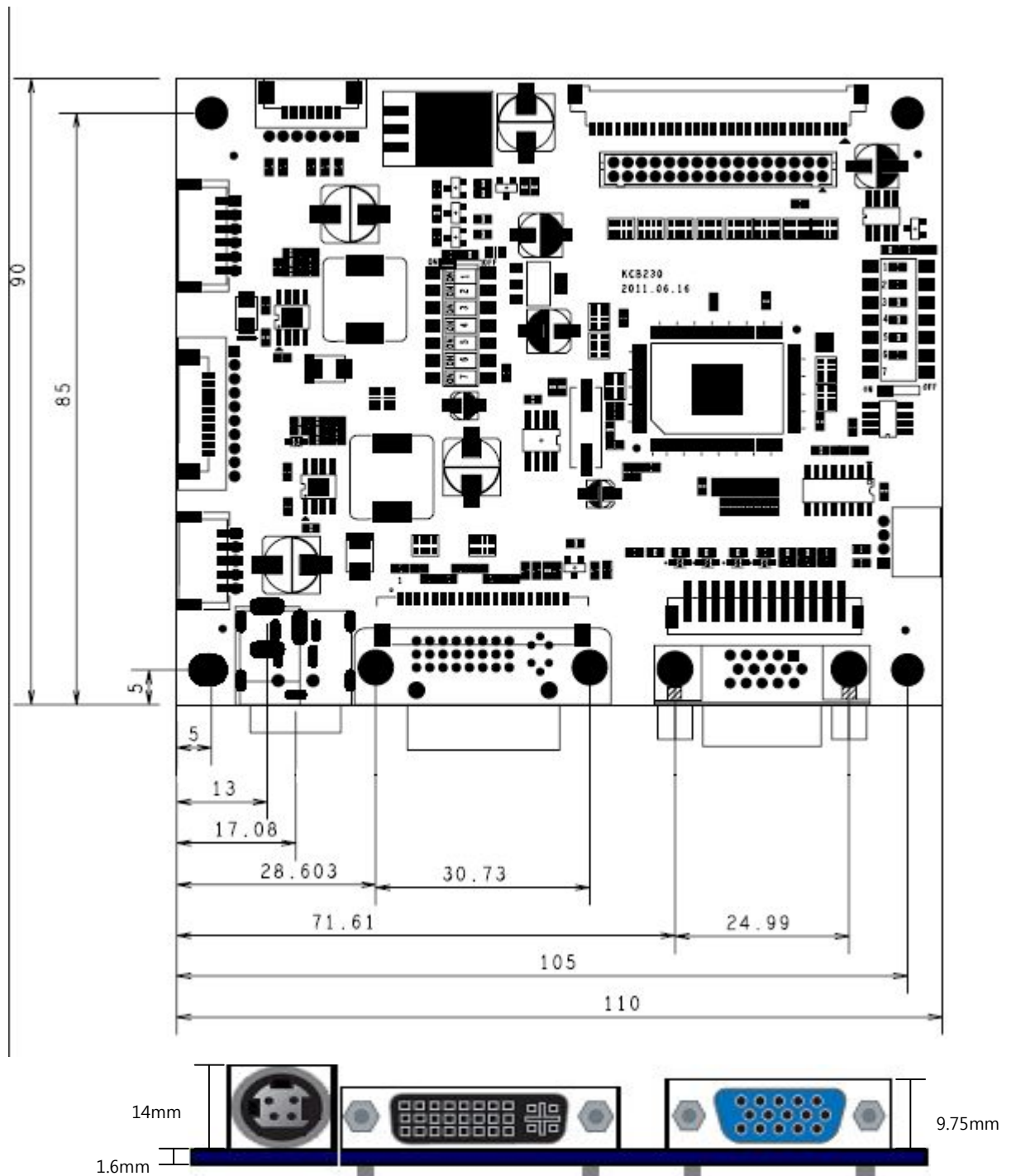

APPLICATION NOTES

USING THE CONTROLLER WITHOUT BOTTONS ATTACHED

This is very straightforward:

- Firstly setup the controller/display system with the buttons. With the attached controllers and display system active make any settings for color, contrast and image position as required then switch everything off.
- Remove the control switches, the 7-wired cable.
- Refer to inverter specifications for details as to fixing brightness to a desired level, this may require a resistor, an open circuit or closed circuit depending on inverter

INVERTER CONNECTION

There are 3 potential issues to consider with inverter connection:

- Power
- ON/OFF
- Brightness (DIM-ADJ)

Inverter power: This should be matched with the inverter specification.

Inverter ON/OFF: This is a pin provided on some inverter for ON/OFF function and is used by this panel controller for VESA DPMS compliance. If the inverter does not have on/off pin or the on/off pin is not used DPMS will not operate. Pin 5 should be matched to the inverter specification for the ON/OFF pin.

Brightness Dimming control: The controller boards are analog dimming control method. And it is important to consider the specifications for the inverter to be used.

TROUBLESHOOTING

General

A general guide to troubleshooting of a flat panel display system it worth considering the system as separate elements, such as:

- Controller (jumpers, PC settings)
- Panel (controller, cabling, connection, panel, PC settings)
- Backlight (inverter, cabling, connection, panel, Pc settings)
- Cabling
- Computer system (display settings, operating system)

Through checking the system step by step cross with instruction manuals and a process of elimination to isolate the problem it is usually possible to clearly identify the problem area.

No image:

- If the panel backlight is not working it may still be possible to see just some image.
- A lack of image is most likely to be caused by incorrect connection, lack of power, failure to provide a signal or incorrect graphic card settings.

Image position:

If it is impossible to position the image correctly, the image adjustment controls will not move the image far enough, then test using another graphics card. This situation can occur when a graphic card is not close to standard timing or when something is in the graphics line that may affect the signal such as a signal splitter (please note that normally a signal splitter will not have any adverse effect).

Image appearance:

- A faulty panel can have blank lines, failed sections, flickering or flashing display.
- Incorrect graphic card refresh rate, resolution or interlaced mode will probably cause the image to be the wrong size, to scroll to, flicker badly or possibly even no image.
- Incorrect jumper settings on the controller may cause everything from incorrect image viewing to total failure.

CAUTION: Do not set the panel power input incorrectly.

- Sparkling on the display: faulty panel signal cable.

Backlight:

Items to check include: Power input, controls, inverter and Tubes generally in this order.

If half the screen is dimmer than the other half:

- Check cabling for the inverter.

APPLICABLE GRAPHIC MODE

The microprocessor measures the, H – sync V – sync and polarity for RGB Inputs, and uses this timing information to control all of the display operation to get the proper image on a screen. This board can detect all VESA standard Graphic modes shown on the table below and Provide more clear and stable image on a screen

Table 6.1) RGB input format

Spec Mode	Pixel Freq.	Horizontal Timing				Vertical Timing			
		Sync Polar	Freq.	Total	Active	SP	Freq.	Total	Active
	MHz		KHz	Pixel	Pixel		Hz	Line	Line
640*350@70Hz	25.144	P	31.430	800	640	N	70.000	449	350
640*400@70Hz	28.287	N	31.430	800	640	P	70.000	449	400
720*400@ 70Hz	28.287	N	31.430	900	720	P	70.000	449	400
640*480@60Hz	28.175	N	31.469	800	640	N	59.940	525	480
640*480@72Hz	31.500	N	37.861	832	640	N	72.809	520	480
640*480@75Hz	31.500	N	37.500	840	640	N	75.000	500	480
800*600@56 Hz	36.000	P	35.156	1024	800	P	56.250	625	600
800*600@60Hz	40.000	P	37.879	1056	800	P	60.317	628	600
800*600@72Hz	50.000	P	48.077	1040	800	P	72.188	666	600
800*600@75Hz	49.500	P	46.875	1056	800	P	75.000	625	600
1024*768@60Hz	65.000	N	48.363	1344	1024	N	60.005	806	768
1024*768@ 70Hz	75.000	N	56.476	1328	1024	P	70.070	806	768
1024*768@75Hz	78.750	P	60.023	1312	1024	P	75.030	800	768
1280*720@60Hz	74.500	P	44.772	1664	1280	P	59.855	748	720
1280*768@60Hz	68.250	P	47.396	1440	1280	N	59.995	790	768
1360*768@60Hz	84.75	P	47.72	1776	1360	P	59.799	798	768
1280*1024@60Hz	108.000	P	63.981	1688	1280	P	60.020	1066	1024
1280*1024@75Hz	135.000	P	79.976	1688	1280	P	75.035	1066	1024
1440*1050@60Hz	101.000	P	64.744	1560	1400	N	59.948	1080	1050
1680*1050@60Hz	119.125	P	64.742	1840	1680	N	59.946	1080	1050
1600*1200@60Hz	162,000	P	75,000	2160	1600	P	60.00	1250	1200
1920*1080@60Hz	138.625	P	66.647	2080	1920	N	59.988	1111	1080
1920*1200@60Hz	154.125	P	74.099	2080	1920	N	59.999	1235	1200

ACCESSORY

This board requires several accessories to build a complete display unit. We can provide standard accessory for this board as below.

No.	Items	Part No.	Ex) LG Display LM215WF1
1	LCD signal cable	SC- Panel Part No. - mm	
2	Inverter	Part no. of Manufacturer	
3	Inverter cable	IC- S10 - Inverter Part No. - mm	
4	OSD Board	NOB005P	
5	OSD Cable	OC- S07 - OSD Part No – mm	