

# mass integrated

global part distribution • product lifecycle partner  
excess inventory management • value-ad service provider



Data sheet provided by Mass Integrated

[massintegrated.com](http://massintegrated.com) • [displayalliance.com](http://displayalliance.com)

Please call +1.978.465.6190  
Email: [sales@massintegrated.com](mailto:sales@massintegrated.com)



ISO 9001: 2008

Mass Integrated complies with all DMCA takedown notices. Please send a formal DMCA Takedown Notice to Mass Integrated Systems, Inc. • 18 Henry Graf Jr. Road, Unit 1 • Newburyport, MA 01950.

To : \_\_\_\_\_

TENTATIVE

## Specification of FUJITSU TFT-LCD module

**FLC26XGC6R**

### Approval

Date :

By :

This Product is designed, developed and manufactured as contemplated for general use, including without limitation, general office use, personal use, household use, and ordinary industrial use, but is not designed, developed and manufactured as contemplated for use accompanying fatal risks or dangers that, unless extremely high safety is secured, could lead directly to death, personal injury, severe physical damage or other loss (hereinafter "High Safety Required Use"), including without limitation, nuclear reaction control in nuclear facility, aircraft flight control, air traffic control, mass transport control, medical life support system, missile launch control in weapon system. If customer's product possibly falls under the category of High Safety Required Use, please consult with our sales representatives in charge before such use. In addition, FDTC shall not be liable against the customer and/or any third party for any claims or damages arising in connection with the High Safety Required Use of the Product without permission.

Specification No. : Tech Bes LCD-00185

Issue Date : Jan. 31, 2003

Issued by : F.Yamada

FUJITSU DISPLAY TECHNOLOGIES CORPORATION



TENTATIVE

TABLE OF CONTENTS

1 . APPLICATIONS ..... 3

2 . PRODUCT NAME AND MODEL NAME ..... 3

    2-1.Product Name ..... 3

    2-2.Model Name ..... 3

3 . OVERVIEW ..... 3

4 . CONFIGURATION ..... 4

5 . MECHANICAL SPECIFICATIONS ..... 5

6 . ABSOLUTE MAXIMUM RATING ..... 5

7 . RECOMMENDED OPERATING CONDITIONS ..... 6

8 . ELECTRICAL SPECIFICATIONS ..... 8

9 . OPTICAL SPECIFICATIONS ..... 13

10 . INTERFACE SPECIFICATIONS ..... 14

    10-1.Signal Descriptions and Data Assignment of LVDS ..... 16

    10-2.Digitizer Sensor Board Interface ..... 16

    10-3. Color Data Assignment ..... 17

    10-4. Input Signal Timing ..... 18

    10-5. Correspondence between Data and Display Position ..... 20

    10-6.Power Supply Sequence ..... 20

    10-7.Shut Down Time ..... 21

11 . FRONT-LIGHT SPECIFICATIONS ..... 21

    11-1.Pin configuration for Front-light ..... 21

    11-2.Cold Cathode Fluorescent Tube Specification ..... 21

    11-3.Life ..... 21

12 . APPEARANCE SPECIFICATIONS ..... 22

    12-1.Zone ..... 22

    12-2.Bright Spots ..... 22

    12-3.Test Condition ..... 22

    12-4.Specification ..... 22

13 . ENVIRONMENTAL SPECIFICATIONS ..... 24

14 . INDICATIONS ..... 25

15 . PACKAGING ..... 25

16 . WARRANTY ..... 26

17 . PRECAUTIONS ..... 26

18 . PRECAUTIONS FOR USE ..... 29

19 . MISCELLANEOUS ..... 29

A

A

B

B

C

C

D

D

E

DATE DOCUMENT CONTROL SECTION

						TITLE		FLC26XGC6R	
						DRAW. NO.		Tech Bes LCD-00185	
								CUST.	
EDIT	DATE	DESIG.	CHECK	APPR.	DESCRIPTION		FUJITSU DISPLAY TECHNOLOGIES CORPORATION		2 /
	DESIG.		CHECK		APPR.				

F

TENTATIVE

**1. APPLICATION**

This specification is applied to the 10.4-inch XGA supported TFT-LCD module.

A

A

**2. PRODUCT NAME AND MODEL NAME**

2-1 Product Name : LCD Module

2-2 Model Name : FLC26XGC6R

**3. OVERVIEW**

B

B

This LCD module has a TFT active matrix type liquid crystal panel 1024x3(RGB)x768 pixels, and diagonal size of 26cm. This LCD has a RGB interface for XGA and can display 262,144 colors under non-interlaced mode.

This LCD module can display under the bright light very clearly, also can display plainly in the dark place due to the front light.

It has built-in edge type front-light with 1CCFL which is driven by external inverter for this front-light.

C

C

The power supply of this LCD module is +3.3V DC voltage. (It is not included with the power source for front light and Digitizer unit.)

The timing control signal consists of data-ENAB signal only. It is possible to display freely within regulation.

D

D

The interface uses LVDS interface. This LCD module installs the digitizer unit of electromagnetic induction tablet device.

**4. CONFIGURATION**

This LCD module consists of a reflected color TFT-LCD panel on which TFT driver ICs are mounted, a bezel, a CCFL front-light, digitizer unit for tablet device, and LVDS interface PCB.

The inverter for the front-light is not included.

Figure 4-1 shows a block diagram of this LCD module.

E

DATE DOCUMENT CONTROL SECTION

						TITLE		FLC26XGC6R	
						DRAW. NO.		Tech Bes LCD-00185	
								CUST.	
EDIT	DATE	DESIG.	CHECK	APPR.	DESCRIPTION		FUJITSU DISPLAY TECHNOLOGIES CORPORATION		3/

F

TENTATIVE

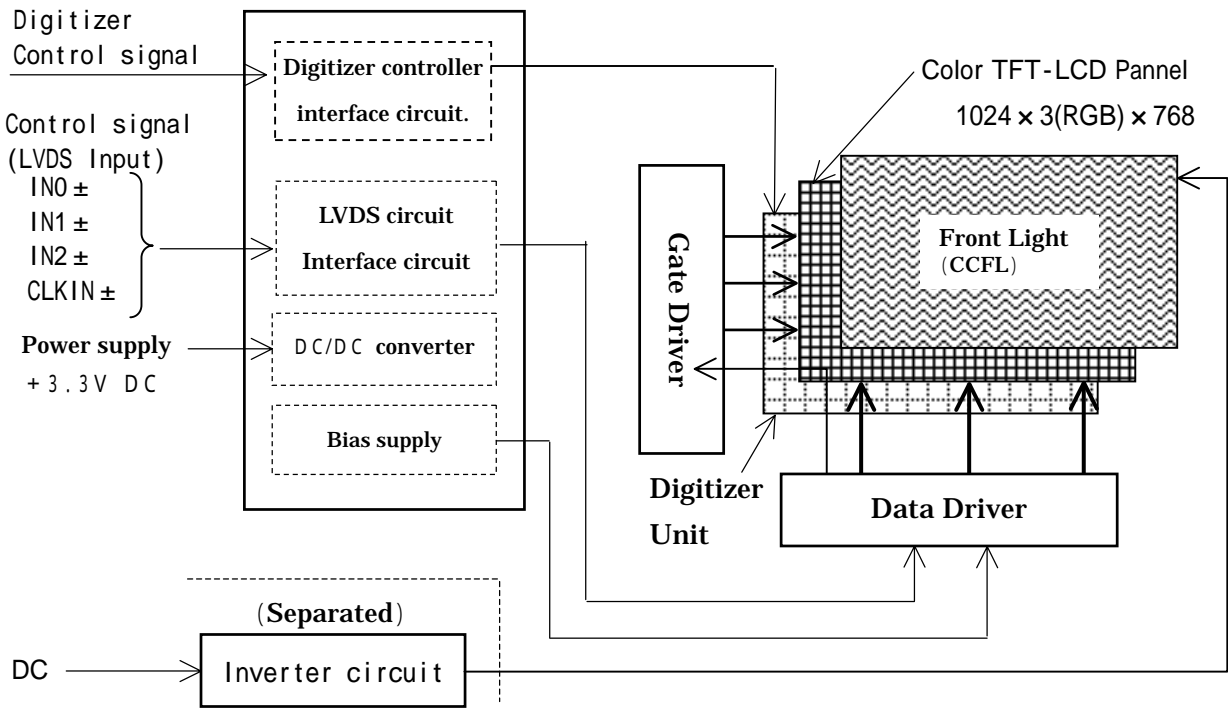

Figure 4-1 Block Diagram

**5. MECHANICAL SPECIFICATIONS**

Table 5-1 shows the mechanical specifications of this LCD module.

**Table 5-1 Mechanical Specifications**

Item	Specifications	Unit	Remark
Dimensions	235.6 x 173.2 x 6.8	mm	Edge type front-light is used. ( 1.8 CCFLx1)
Display Resolution	(1024 x 3) x 768	—	Without inverter.
Display Dot Area	210.432 x 157.824	mm	For details on dimensions, see dimensional outline drawing. (at page 32,33,34:Figure 19-1,2,3)
Dot Pitch	(0.0685x3)x0.2055	mm	
Pixel Aspect Ratio	1:1	—	
Weight	330 MAX	g	
FG - SG	Short	—	

DOCUMENT CONTROL SECTION

DATE

						TITLE		FLC26XGC6R	
						DRAW. NO.		Tech Bes LCD-00185	
								CUST.	
EDIT	DATE	DESIG.	CHECK	APPR.	DESCRIPTION		FUJITSU DISPLAY TECHNOLOGIES CORPORATION		4 /
		DESIG.		CHECK		APPR.			

TENTATIVE

**6. ABSOLUTE MAXIMUM RATING**

Table 6-1 shows the absolute maximum rating of this LCD module.

Table 6-1 Absolute Maximum Rating

Item	Symbol	Condition	MIN.	TYP.	MAX.	Unit
Supply Voltage (3.3V)	V <sub>CC</sub>	Ta=25°C	-0.3	—	4.0	V
Input Signal Voltage(LVDS)	V <sub>IN</sub>		-0.3	—	V <sub>CC</sub> +0.3	V

**7. RECOMMENDED OPERATING CONDITIONS**

Table 7-1 shows the recommended operating conditions of this LCD module.

Table 7-1 Recommended Operating Conditions

Item	Symbol	MIN.	TYP.	MAX.	Unit
Supply Voltage	V <sub>CC</sub>	3.0	3.3	3.6	V
Ripple Voltage (V <sub>CC</sub> )	V <sub>RP</sub>			100	mV

DATE DOCUMENT CONTROL SECTION

						TITLE		FLC26XGC6R	
						DRAW. NO.			CUST.
						Tech Bes LCD-00185			
EDIT	DATE	DESIG.	CHECK	APPR.	DESCRIPTION		FUJITSU DISPLAY TECHNOLOGIES CORPORATION		5 /
DESIG.			CHECK		APPR.				

### 8. ELECTRICAL SPECIFICATIONS

Table 8-1 shows the electrical specifications of this LCD module. Figure 8-1 shows the measurement circuit. Figure 8-2 shows the equivalent circuit of the logic signal input area.

**Table 8-1 Electrical Specifications**

Item	Symbol	Condition	MIN.	TYP.	MAX.	Unit		
Differential-input Voltage (+)	$V_{IH}$	$V_{cm}=+1.2V$			100	mV		
Differential-input Voltage (-)	$V_{IL}$		- 100			mV		
Supply Current	$I_{CC}$	$V_{CC}=+3.3V$ $V_{SS}=0V$ $T_a=25$ $CK=65MHz$ Frame frequency $=60Hz$		195	325	mA		
Supply Rush Current	$I_{SCC}$		1.7			A		
Supply Rush Current Duration (excess 1.2A)	$T_{SCC}$		1			ms		
FRONT LIGHT	CCFL Turn on Voltage	$V_S$	$f_L=65kHz, T_a=25$ $C_L=22pF$		1100	1200	Vrms	
			$f_L=65kHz, T_a=0$			1200	Vrms	
	Lighting Voltage	$V_L$	$f_L=65kHz, I_L=5mArms$			630	Vrms	
	Lighting Frequency	$f_L$	$V_L=630Vrms,$ $I_L=5mA$		50	65	80	kHz
	Recommended Lighting Frequency							kHz
	Tube Current	$I_L$	$V_L=630Vrms$ $f_L=65kHz$		4.0	5.0	6.0	mArms

Measurement circuit is based on Figure 8-1.

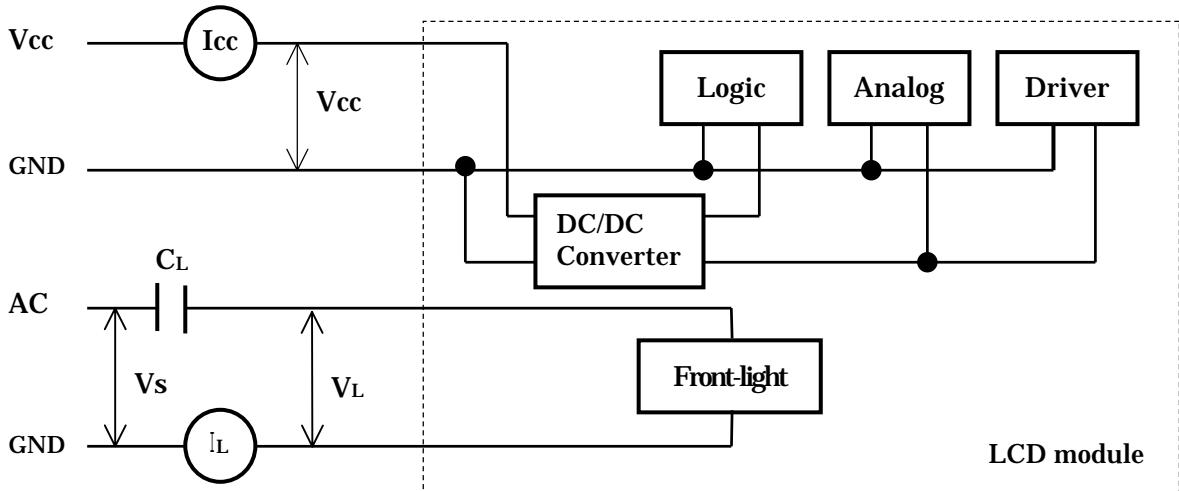

**Figure 8-1 Measurement circuit**

DOCUMENT CONTROL SECTION

DATE

					TITLE	
					FLC26XGC6R	
					DRAW. NO.	
					Tech Bes LCD-00185	
					CUST.	
EDIT	DATE	DESIG.	CHECK	APPR.	DESCRIPTION	
DESIG.			CHECK		FUJITSU DISPLAY TECHNOLOGIES CORPORATION	
					6 /	F

TENTATIVE

DS90CR583(National Semiconductor) or equivalent

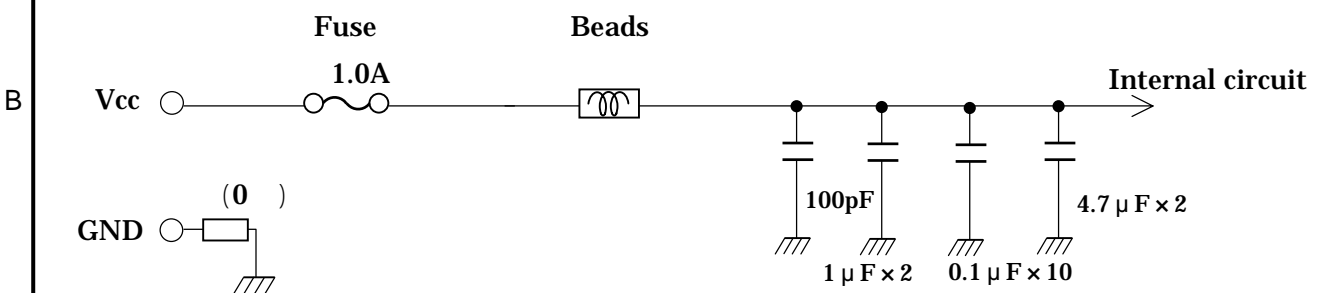
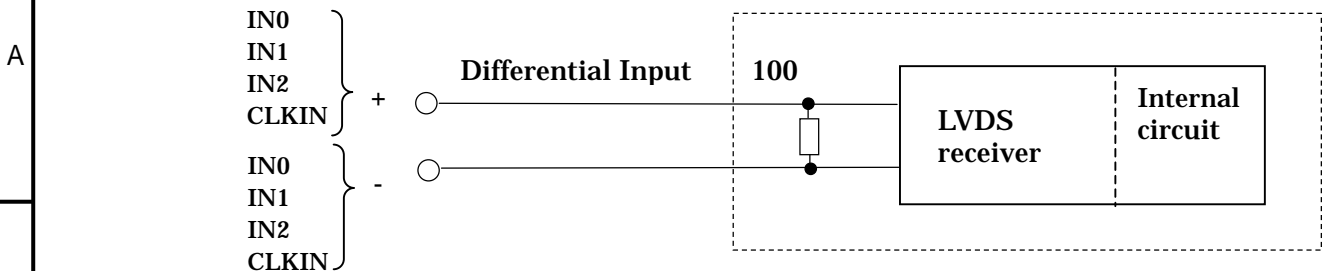

Fuse.....KAB3202102NA29 1.0A  
 (Matsuo Electric Co., LTD.) or equivalent  
 Beads.....MPZ2012 S331A T000 (TDK Co., LTD.)  
 or equivalent

Figure 8-2 Equivalent circuit of logic signal input

DATE DOCUMENT CONTROL SECTION

						TITLE	
						FLC26XGC6R	
						DRAW. NO.	
						Tech Bes LCD-00185	
						CUST.	
EDIT	DATE	DESIG.	CHECK	APPR.	DESCRIPTION		FUJITSU DISPLAY TECHNOLOGIES CORPORATION
DESIG.			CHECK	APPR.			

7/

TENTATIVE

## 9. OPTICAL SPECIFICATIONS

Table 9-1 shows the optical specifications of this LCD module.

Table 9-1 Optical Specifications

Item	Symbol	Condition	Specification			Unit	Front Light	Note			
			MIN.	TYP.	MAX.						
Horizontal Visual Angle	L, R	CR 2	$U, D = 0^\circ$	55			deg	OFF	4,6,8,10		
				45				ON	1,2,6,7,8,10		
Vertical Visual Angle	U	CR 2	$L, R = 0^\circ$	55			deg	OFF	4,6,8,10		
				70				ON	1,2,6,7,8,10		
	D			55				OFF	4,6,8,10		
				40				ON	1,2,6,7,8,10		
Contrast Ratio	C R	$L, R, U, D = 0^\circ$ $s = 25^\circ$	(30)	40			OFF	3,6			
		$L, R, U, D = 0^\circ$	(16)	18			ON	1,2,6,8,10			
Response Time (ON) (B W)	$t_{on}$	$L, R, U, D = 0^\circ$	Ta=25	-	15	30	ms	ON	1,2,6,9,10		
			Ta=0	-	50	100	ms				
Response Time (OFF) (W B)	$t_{off}$	$L, R, U, D = 0^\circ$	Ta=25	-	10	25	ms				
			Ta=0	-	50	100	ms				
Reflectivity	R	$L, R, U, D = 0^\circ$ $s = 25^\circ$	(13)	15			%	OFF	3,6		
Brightness	I	$L, R, U, D = 0^\circ$ $V_{CC} = 3.3V,$ $I_L = 5mA$	(30)	35			cd/m <sup>2</sup>	ON	1,2,6		
Brightness Uniformity	I		65				%	ON	1,2,6,12		
Chromaticity	W		x		(0.32)			-	OFF	5	
			y	(0.283)	0.313	(0.343)		-	ON	1,2,6	
	R G B		x, y		(0.35)				-	OFF	5
					(0.299)	0.329	(0.359)		-	ON	1,2,6
				R		-				OFF	5
					(0.45, 0.31)	Typ.				ON	1,2,6
G			-				OFF	5			
	(0.32, 0.41)		Typ.				ON	1,2,6			
B		-				OFF	5				
	(0.21, 0.24)	Typ.				ON	1,2,6				
LCD Panel Type			TFT Color								
Display Mode			Normally Black VA								
Panel Technology			MVA-R								
Optimum Viewing Angle			none				OFF				
			Top (12 o'clock Direction)				ON		11		
Display Color			262,144 (6-bit color)								
Surface Treatment			None (Front-Light Prism surface)								

· Specified value is measured in 15 ~ 20 minutes after lighting on.

· All items without "Brightness Uniformity" are measured at the center of display board.

DOCUMENT CONTROL SECTION

DATE

TITLE

FLC26XGC6R

DRAW. NO.

Tech Bes LCD-00185

CUST.

EDIT DATE

DESIG.

CHECK

APPR.

DESCRIPTION

FUJITSU DISPLAY TECHNOLOGIES CORPORATION

SHEET

8 /

DESIG.

CHECK

APPR.

**TENTATIVE**

Note 1) Brightness is measured by CS-1000(MINOLTA Co., LTD.), BM-5A(TOPCON Co., LTD.),or equivalent.

Field = 2 ° , Interval = 500mm

Note 2) This LCD module's specifications of Visual Angle, Contrast Ratio, Brightness, Brightness Uniformity, and Chromaticity are measured in the dark condition (under 1lux).

Note 3) Definition of reflectivity

**All-directional Ring light irradiation**

It is measured by CM-512m3(MINOLTA Co., LTD.)or equivalent.

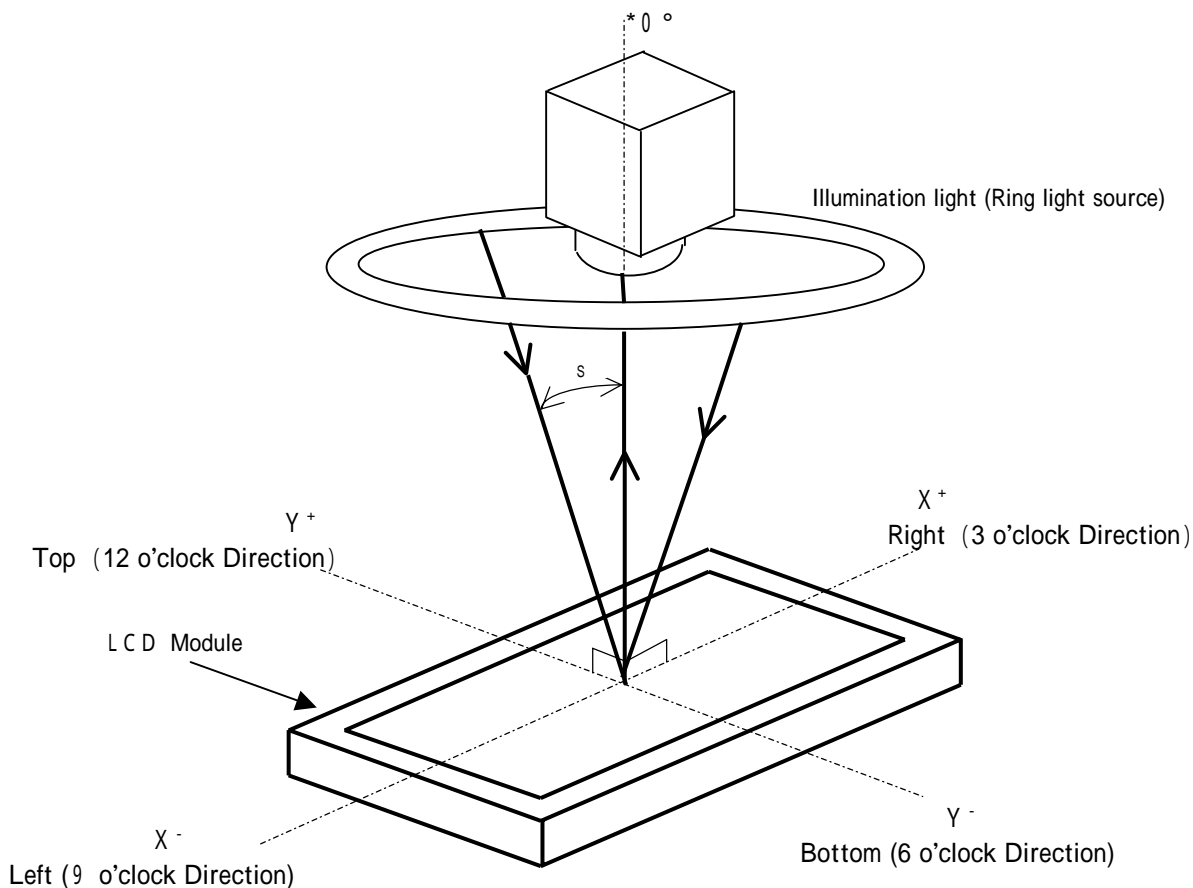

DOCUMENT CONTROL SECTION

						TITLE <b>FLC26XGC6R</b>	
						DRAW. NO. <b>Tech Bes LCD-00185</b>	
						CUST.	
EDIT	DATE	DESIG.	CHECK	APPR.	DESCRIPTION	FUJITSU DISPLAY TECHNOLOGIES CORPORATION	
DESIG.			CHECK		APPR.	9 /	

**TENTATIVE**

**Note 4) Measuring method of reflective viewing angle**  
It is measured by LCD-7000  
(OTSUKA ELECTRONICS CO., LTD)

**Note 5) Measuring Method of Chromaticity at reflection**  
**All-directional diffusion irradiation**  
It is measured by CM-2022(MINOLTA CO., LTD).

A

A

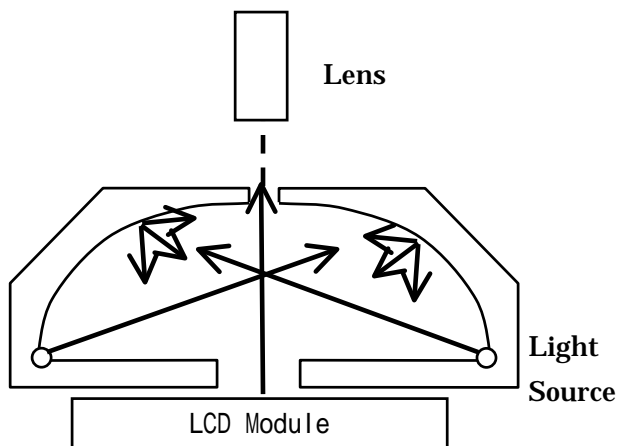

B

B

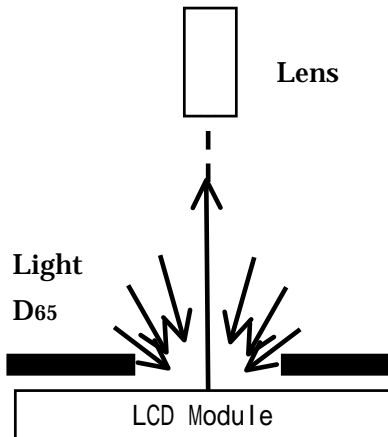

**Note 6) Definition of Viewing Angle (1)**

Based on Figure 9-2.

C

C

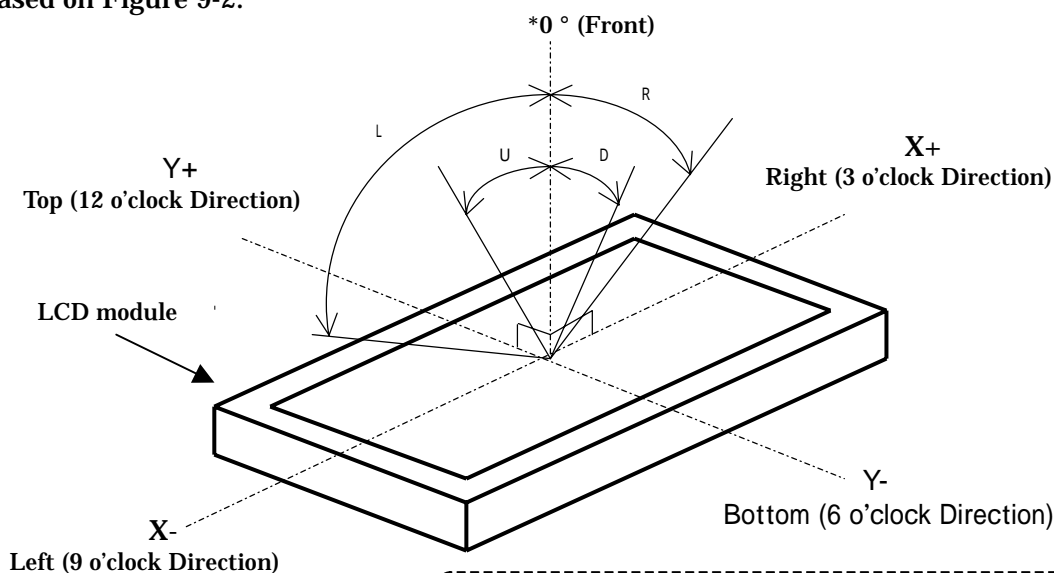

D

D

\*  $U = 0^\circ, D = 0^\circ, L = 0^\circ, R = 0^\circ$

**Figure 9-2 Definition of Viewing Angle (1)**

DATE	DOCUMENT CONTROL SECTION
------	--------------------------

E

F

					TITLE <b>FLC26XGC6R</b>	
					DRAW. NO. <b>Tech Bes LCD-00185</b>	
					CUST.	
EDIT	DATE	DESIG.	CHECK	APPR.	DESCRIPTION FUJITSU DISPLAY TECHNOLOGIES CORPORATION	
DESIG.			CHECK	APPR.	10/	

**Note 7) Definition of Viewing Angle (2)**

Based on Figure 9-3.

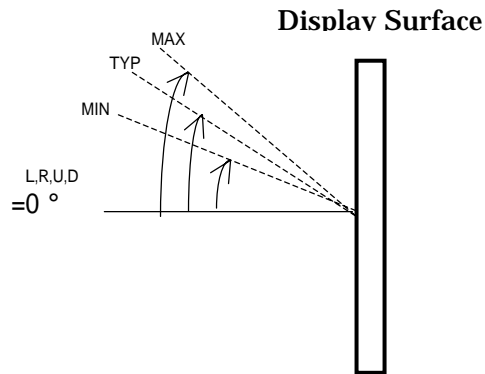
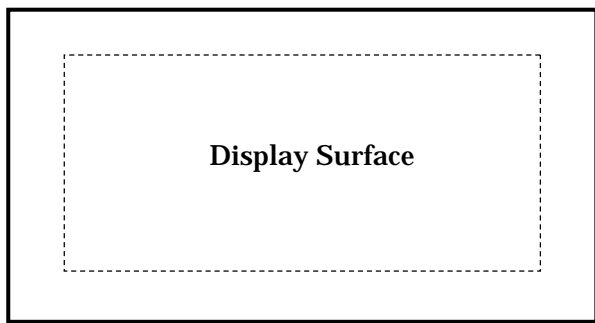
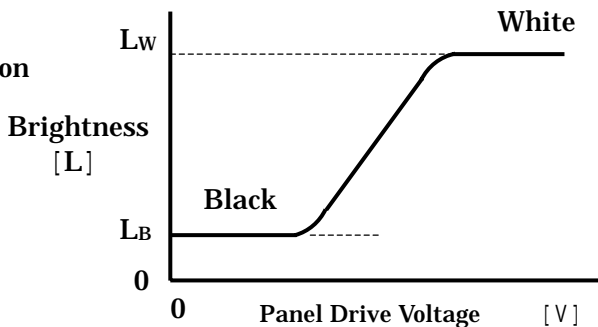

**Figure 9-3 Definition of Viewing Angle (2)**

**Note 8) Definition of Contrast Ratio (CR)**

Determined by Formula (1) based on Figure 9-4 Voltage-Brightness characteristics.

$$CR = \frac{L_W \text{ (Brightness at white)}}{L_B \text{ (Brightness at black)}} \dots\dots(1)$$



**Figure 9-4 Voltage-Brightness Characteristics**

**Note 9) Definition of Response Time**

Based on Figure 9-5.

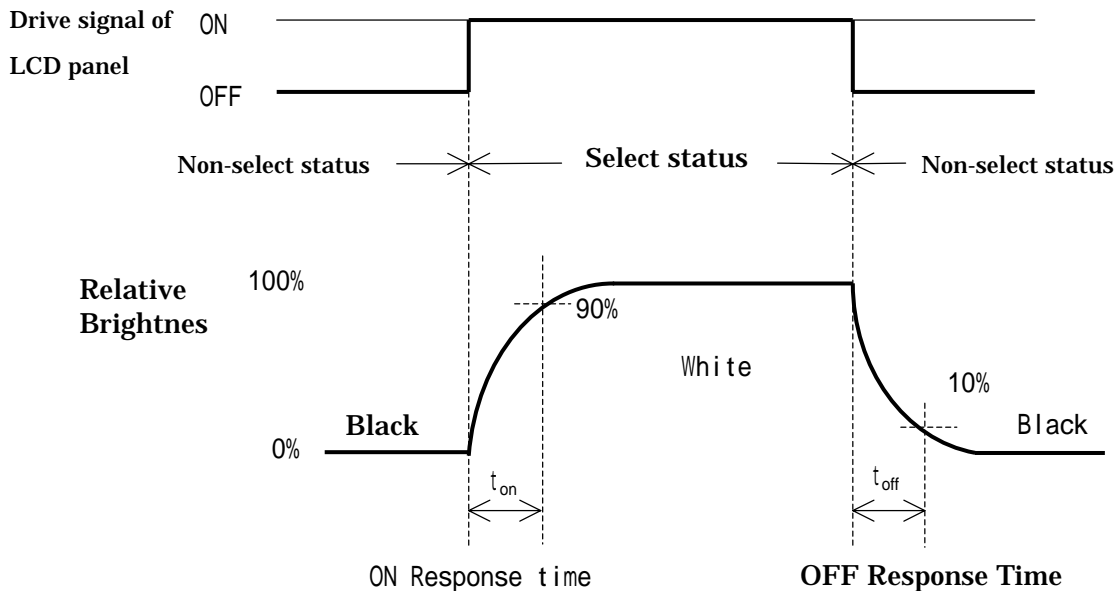

**Figure 9-5 Definition of Response Time**

DATE	DOCUMENT CONTROL SECTION

						TITLE <b>FLC26XGC6R</b>	
						DRAW. NO. <b>Tech Bes LCD-00185</b>	
						CUST. 	
EDIT	DATE	DESIG.	CHECK	APPR.	DESCRIPTION	FUJITSU DISPLAY TECHNOLOGIES CORPORATION	
DESIG.			CHECK				11 /

TENTATIVE

**Note 10) Contrast Ratio and Response Measurement System**

Based on Figure 9-6.

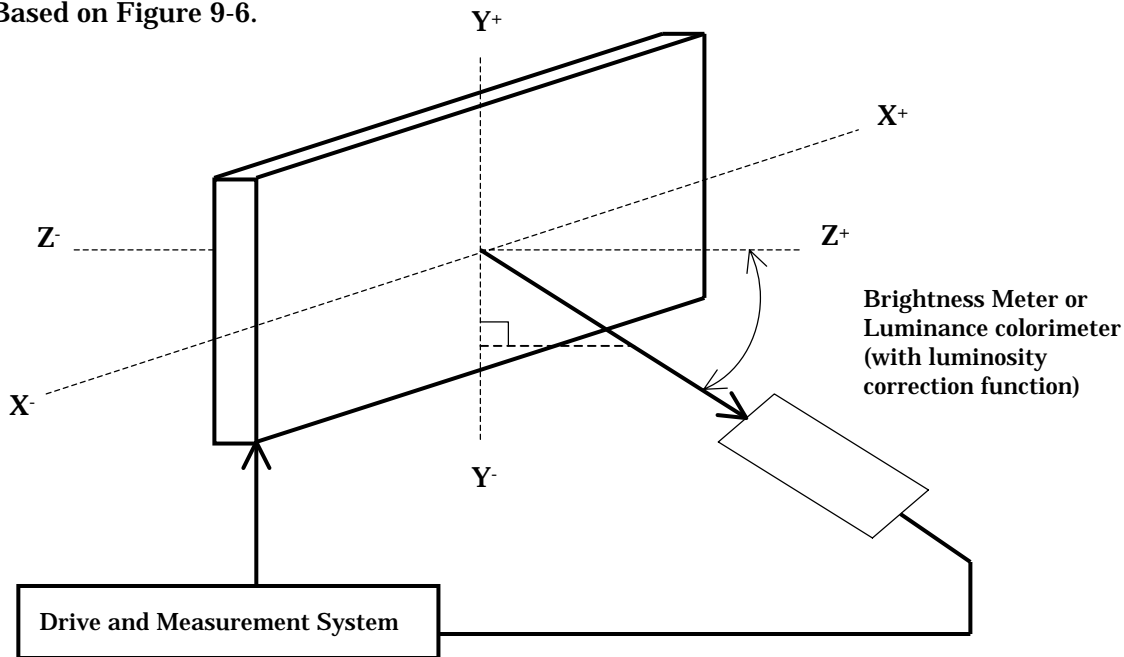

**Figure 9-6 Contrast Ratio and Response Time Measurement System**

**Note 11) Definition of Optimum Viewing Angle**

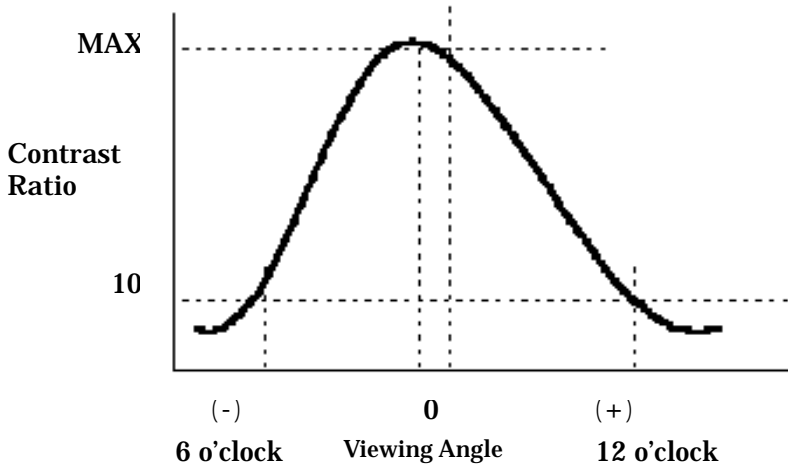

**Figure 9-7 Definition of Viewing Angle**

DOCUMENT CONTROL SECTION

DATE

						TITLE <b>FLC26XGC6R</b>	
						DRAW. NO. <b>Tech Bes LCD-00185</b>	
						CUST.	
EDIT	DATE	DESIG.	CHECK	APPR.	DESCRIPTION	FUJITSU DISPLAY TECHNOLOGIES CORPORATION	
DESIG.			CHECK	APPR.		12/	

TENTATIVE

**Note 12) Definition of Brightness Uniformity**

Brightness uniformity is defined by the following formula.

Brightness art measured at the following 9 points ( ~ ) on the display area that is shown in Figure 9-8.

$$\text{Brightness Uniformity} : \{ (\text{Min. Brightness} \sim) / (\text{Max. Brightness} \sim) \} \times 100 [\%]$$

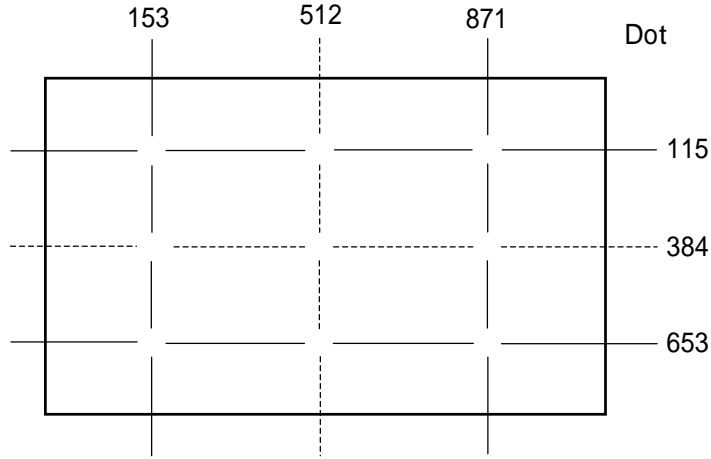

Note) Each measurement point ( ~ ) defines the center spot of view of Brightness Meter. The tolerance of measurement position is ± 3mm.

**Figure 9-8 Measurement Points**

**10. INTERFACE SPECIFICATIONS**

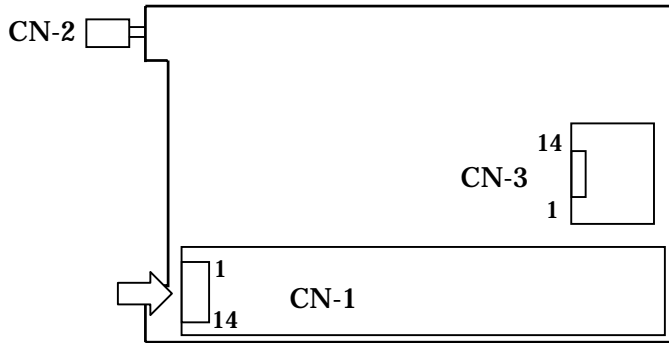

- CN-1 : LCD interface
- CN-2 : Power source of front light
- CN-3 : Digitizer unit Interface

It shows from backside.

DATE DOCUMENT CONTROL SECTION

						TITLE		FLC26XGC6R	
						DRAW. NO.			CUST.
						<b>Tech Bes LCD-00185</b>			
EDIT	DATE	DESIG.	CHECK	APPR.	DESCRIPTION		FUJITSU DISPLAY TECHNOLOGIES CORPORATION		13/
DESIG.			CHECK		APPR.				

TENTATIVE

**10-1 Signal Descriptions and Data assignment of LCD**

Table 10-1 shows the Signal Description of LCD (CN1).

Table 10-2 shows the LVDS Data Assignment.

**Table 10-1 Interface signals (CN1)**

Pin No.	Symbol	Function
1	VCC	+ 3.3V power supply
2	VCC	+ 3.3V power supply
3	VSS	GND
4	VSS	GND
5	IN0 -	LVDS signal IN0 -
6	IN0 +	LVDS signal IN0 +
7	IN1 -	LVDS signal IN1 -
8	IN1 +	LVDS signal IN1 +
9	IN2 -	LVDS signal IN2 -
10	IN2 +	LVDS signal IN2 +
11	CLKIN -	LVDS signal CLKIN -
12	CLKIN +	LVDS signal CLKIN +
13	VSS	GND
14	VSS	GND

Connector : DF19L - 14P - 1H  
 Conformed Connector : DF19G - 14S - 1C  
 Producer : HIROSE ELECTRIC CO., LTD.

DATE DOCUMENT CONTROL SECTION

						TITLE <b>FLC26XGC6R</b>		
						DRAW. NO.		CUST.
						<b>Tech Bes LCD-00185</b>		
EDIT	DATE	DESIG.	CHECK	APPR.	DESCRIPTION	FUJITSU DISPLAY TECHNOLOGIES CORPORATION		14/
DESIG.			CHECK		APPR.			

TENTATIVE

Table 10-2 LVDS Data Assignment

Graphic Controller Input Signal	Transmitter pin assignment						LCD connector pin assignment
	Input from Graphic Controller			Output to LCD module			
	Pin No.	SN75LVDS84 (TI)	DS90CR563 (NS)	Pin No.	SN75LVDS84 (TI)	DS90CR563 (NS)	
Red 0 (LSB)	44	D0	TxIN0	41	Y1M	TxOUT0 -	5 (IN0 -)
Red 1	45	D1	TxIN1				
Red 2	47	D2	TxIN2				
Red 3	48	D3	TxIN3				
Red 4	1	D4	TxIN4	40	Y2P	TxOUT0 +	6 (IN0 +)
Red 5 (MSB)	3	D5	TxIN5				
Green 0(LSB)	4	D6	TxIN6				
Green 1	6	D7	TxIN7	39	Y2M	TxOUT1 -	7 (IN1 -)
Green 2	7	D8	TxIN8				
Green 3	9	D9	TxIN9				
Green 4	10	D10	TxIN10				
Green 5(MSB)	12	D11	TxIN11	38	Y1P	TxOUT1 +	8 (IN1 +)
Blue 0 (LSB)	13	D12	TxIN12				
Blue 1	15	D13	TxIN13				
Blue 2	16	D14	TxIN14	35	Y3M	TxOUT2 -	9 (IN2 -)
Blue 3	18	D15	TxIN15				
Blue 4	19	D16	TxIN16				
Blue 5 (MSB)	20	D17	TxIN17				
HRSVD	22	D18	TxIN18	34	Y3P	TxOUT2 +	10 (IN2 +)
VRSVD	23	D19	TxIN19				
ENAB	25	D20	TxIN20				
CK	26	CLKIN	TxCLK IN	33	CLKOUTM	TxCLK OUT -	11 (CLKIN -)
				32	CLKOUTP	TxCLK OUT +	12 (CLKIN +)

DOCUMENT CONTROL SECTION

DATE

						TITLE <b>FLC26XGC6R</b>	
						DRAW. NO. <b>Tech Bes LCD-00185</b>	
						CUST.	
EDIT	DATE	DESIG.	CHECK	APPR.	DESCRIPTION	FUJITSU DISPLAY TECHNOLOGIES CORPORATION	
DESIG.			CHECK		APPR.	15/	

**10-2 Digitizer Unit Interface (CN-3)**

Table 10-3 shows the Digitizer Unit Interface Data Assignment.

**Table 10-3 Digitizer Unit Interface Data Assignment**

Pin	NAME	IN/OUT	FUNCTION
1	GND		Ground
2	PWS1	OUT	Auxiliary Port1
3	PWS2	OUT	Auxiliary Port2
4	PWS3	OUT	Auxiliary Port3
5	PWS4	OUT	Auxiliary Port4
6	PDCT	OUT	Pen Detect Signal
7	DSR	IN	Data Set Ready Signal
8	CTS	IN	Clear To Send Signal
9	TxD	OUT	Serial Data Output Signal
10	RxD	IN	Serial Data Input Signal
11	SLP	IN	Sleep Signal
12	RES	IN	Reset
13	Vcc		Power Supply (3.3 Volt)
14	GND		Ground

- Connector on SU-001: DF19L-14P-1H / HIROSE ELECTRIC CO., LTD
- Mating Connector (Corresponding Connector)  
: DF19L-14S-1C / HIROSE ELECTRIC CO., LTD

**TxD**      Serial Data Output Signal  
To be connected to Host's RxD

**RxD**      Serial Data Input Signal  
To be connected to Host's TxD

**CTS**      Clear To Send Signal  
To be connected to Host's RTS for Plug & Play

**DSR**      Data Set Ready Signal  
To be connected to Host's DTR for Plug & Play

**PCDT**    Pen Detect output Signal  
This is set "HIGH" while Pen Device detects pen or eraser.  
Leave this open if Host does not use.

**SLP**      Sleep Input Signal  
When set "High", Pen Device stops and goes into sleep mode  
Keep this "Low" if sleep mode is not needed.

**RES**      Reset  
Pen Device stops operating when RES is set "LOW".  
Input "system power on reset" signal.

**PWS1:4**   Auxiliary Port  
Leave this pen.

DATE    DOCUMENT CONTROL SECTION

						TITLE		FLC26XGC6R	
						DRAW. NO.			CUST.
						Tech Bes LCD-00185			
EDIT	DATE	DESIG.	CHECK	APPR.	DESCRIPTION		FUJITSU DISPLAY TECHNOLOGIES CORPORATION		16/
	DESIG.		CHECK		APPR.				



TENTATIVE

10-4 Input Signal Timing

Table 10-5 and Figure 10-3 shows the Input Signal Timing at LVDS transmitter.

Table 10-5 Timing Characteristics

(Ta=0~50°C, Vcc=3.3±0.3V)

Item	Symbol	MIN.	TYP.	MAX.	Unit	Remark	
DCLK signal (Clock)	Period	Tc	15.15	15.38	28.5	ns	f <sub>c</sub> =1/T <sub>c</sub> *1
	Frequency	fc	35	65	66	MHz	
	Duty	Tch/Tc	45	50	55	%	
	High Time	TclkH	6			ns	
	Low Time	TclkL	6			ns	
	Rise Time	Tclkr			5.0	ns	
	Fall Time	Tclkf			5.0	ns	
DCLK-Data Timing	Setup time	Tset	3.0			ns	(65MHz)
	Hold time	Thold	7.0			ns	(65MHz)
Horizontal signal	Period	Th	1320	1344	1566	DCLK	
	Frequency	fh	38.6	48	60	kHz	
	Display period	Thd	1024	1024	1024	DCLK	
Vertical signal	Period	Tv	772	806	868	Th	16.67ms
	Frequency	fv	59.998	59.998	59.998	Hz	
	Display period	Tvd		768		Th	*2
ENAB signal	Data-ENAB timing	Tdn		0		DCLK	*3

\*1) •Clock must be input while the power is on.

\*2) •Horizontal display position is specified by the rise of ENAB signal only.

The data latched at falling edge of DCLK after rise of ENAB is displayed at the left edge of the display area.

•Vertical display position is specified by the rise of "L" ENAB after "H" level continuation over 2 Horizon Period  
The data latched at the rise of ENAB is displayed at the top line of the display area.

\*3) •If High Time ENAB does not synchronize with the effective data period, the display position does not fit to the display area.

DATE DOCUMENT CONTROL SECTION

						TITLE <b>FLC26XGC6R</b>	
						DRAW. NO. <b>Tech Bes LCD-00185</b>	
						CUST.	
EDIT	DATE	DESIG.	CHECK	APPR.	DESCRIPTION	FUJITSU DISPLAY TECHNOLOGIES CORPORATION	
DESIG.			CHECK		APPR.	18/	

TENTATIVE

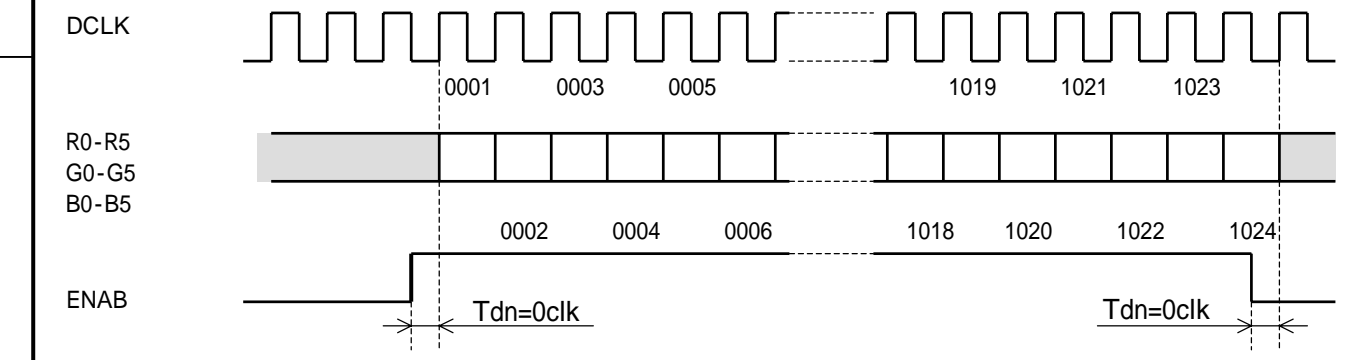
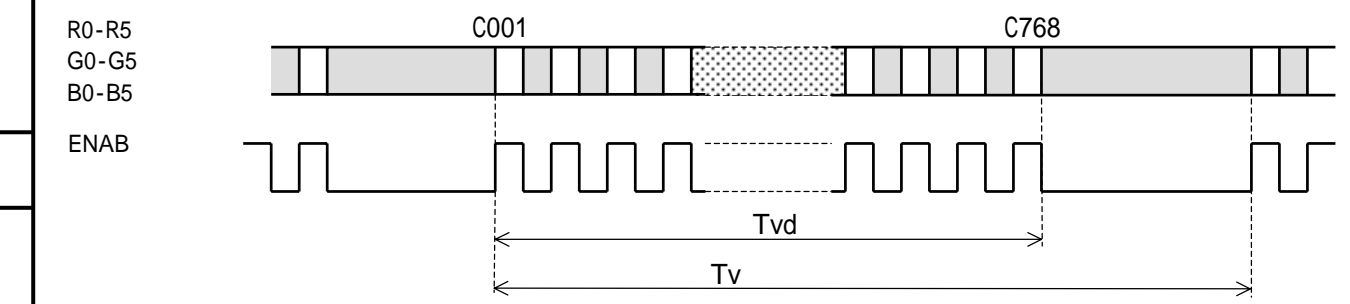
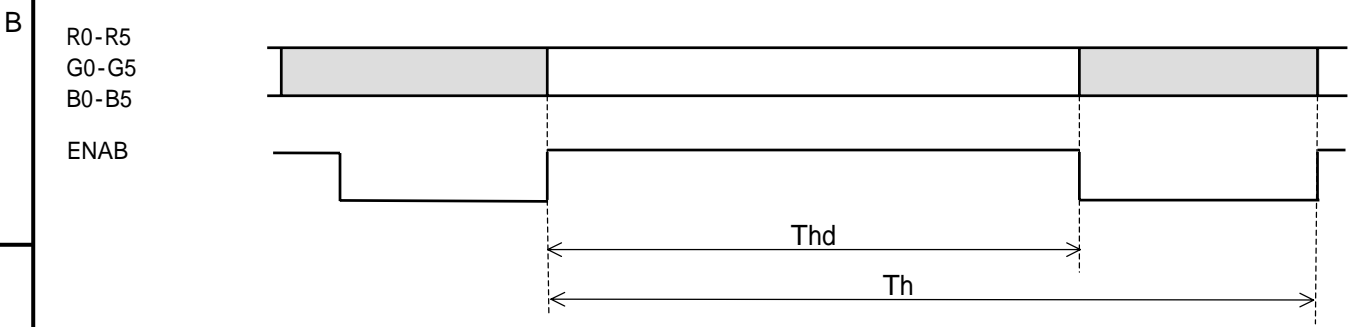
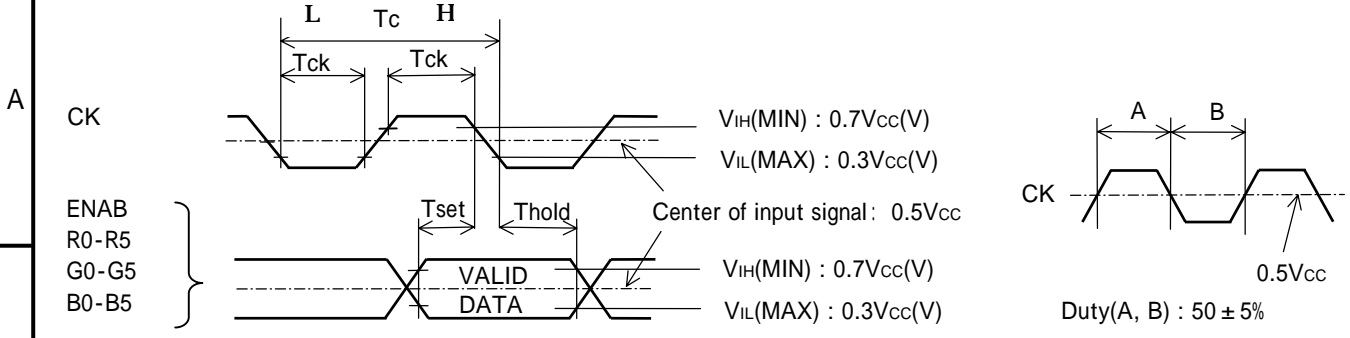

Figure 10-3 Input Signal Timing Chart

DOCUMENT CONTROL SECTION

DATE

						TITLE		FLC26XGC6R	
						DRAW. NO.			CUST.
						Tech Bes LCD-00185			
EDIT	DATE	DESIG.	CHECK	APPR.	DESCRIPTION		FUJITSU DISPLAY TECHNOLOGIES CORPORATION		19 /
DESIG.			CHECK	APPR.					



**10-7 Shut Down Time**

Figure 10-6 shows the specification of shut down time.

If this specification is out of regulation, the last screen before shut down might be afterimage.

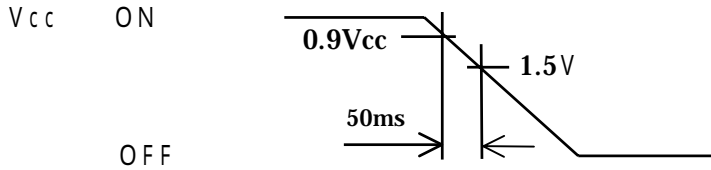

**Figure 10-6 Shut down time**

**11. FRONT-LIGHT SPECIFICATIONS**

**11-1 Pin configuration for Front-light (CN-2)**

Table 11-1 shows the description and Pin assignment of the connectors (CN-2) for the Front-light of this LCD module.

**Table 11-1 Pin Assignment of CN-2**

Pin	Signal	Function
1	VL	Power supply for CCFL
2	GND	GROUND

Connector : Housing : BHSR-02VS-1  
 User's Connector : Post with base: SM02B-BHSS-1  
 Supplier : Japan Solderless Terminal Trading Company LTD. (J.S.T.)

**11-2 CCFL Specification**

Supplier : Sanken Electric Co., Ltd.  
 Catalog Number : NA19026-5401

**11-3 Life**

The life of the front-light is a minimum of 10,000 hours at the following conditions.

**(1) Working conditions**

Ambient temperature: 25 ± 5  
 Tube current (IL) : 5.0mA or less

**(2) Definition of life**

Brightness becomes 50% or less than the minimum brightness value shown in Table 9-1.  
 Turn-on voltage becomes over 1500Vrms shown in Table 8-1.  
 Flashing.

DATE DOCUMENT CONTROL SECTION

						TITLE		FLC26XGC6R	
						DRAW. NO.			CUST.
						Tech Bes LCD-00185			
EDIT	DATE	DESIG.	CHECK	APPR.	DESCRIPTION				FUJITSU DISPLAY TECHNOLOGIES CORPORATION
									21 /

## 12. APPEARANCE SPECIFICATIONS (Tentative)

### 12-1 Zone (Tentative)

- Inside display dot area (210.432×157.824mm)
- Display dot area means active area.
- One pixel consists of 3 dots (red, green and blue).
- Foreign particle and scratch unharmed to display image, such as the foreign particle under polarizer film but outside of the display area and scratch on metal bezel, frontlight module or polarizer film out of the display area, etc., are not counted.

### 12-2 Bright spots (Tentative)

#### (1) Bright spots by the defect of TFT.

- Visible under bias of 2% ND filter .....High bright spot R•G
- Visible under 5% but invisible under 2% ND filter .....Low bright spot R•G•B
- Invisible under bias of 5% ND filter .....Not counted

#### (2) Bright spots by the light passing through tears, breaks, etc in color filter.

- Exceed size of a half dot .....High bright spot
- A half dot or less .....Not counted

#### (3) Bright spots by the light passing through tears, breaks, etc in chromium mask.

- Exceed 50μm .....High bright spot
- 50μm or less .....Not counted

### 12-3 Test condition (Tentative)

- Inspector must observe the LCD screen from the normal direction under the illumination by a single 20W fluorescent lamp. The distance between the LCD screen and the inspector should be a height of 35cm above the worktable.  
The vertical illuminance is 300 to 600lux (reference value).
- Bright spot should be counted under entire black screen.
- Dark spot should be counted under entire white screen.
- The test is performed when frame frequency is 60Hz.

### 12-4 Specification (Tentative)

Figure 12-1 shows the specification.

(Note1) Please do not mistake a single bright spot for a bright spot connection due to Cs(supplemental capacitance) line at the center of each dot.

(Note2) If a pixel is dark partially, it connects into the number of dark spots in accordance with following rule.

- (a)  $S < 1/3$  : Not count. Only one of 4 dark connection is allowed.
- (b)  $1/3 \leq S < 2/3$  : Considered as 0.5 dot.
- (c)  $2/3 \leq S$  : Considered as 1 dot.

(S=Dark spot size/dot size)

DOCUMENT CONTROL SECTION

						TITLE	
						FLC26XGC6R	
						DRAW. NO.	
						Tech Bes LCD-00185	
						CUST.	
EDIT	DATE	DESIG.	CHECK	APPR.	DESCRIPTION		
DESIG.			CHECK		FUJITSU DISPLAY TECHNOLOGIES CORPORATION		
						22 /	22 /

TENTATIVE

Figure 12-1 Appearance (Tentative)

No.	Item	Judgment method and standard	
1	Bright spot (high and Low)	T.B.D	
2	Bright spot connection (high and low)		
3	Total of bright spot		
4	Dark spot		
5	Dark spot connection		
6	Total of dark spot		
7	Total of dot defect (bright and dark)		
8	Distance of bright spot		high-hg others
9	Distance of dark spot		
10	Scratch on polarizer, line shape		
11	Dent on polarizer, dot shape		
12	Bubble in polarizer		
13	Black white spot (Foreign circular matter)		
14	Light leakage by foreign articles		
15	Lints, black/white line by foreign articles		

D:Average diameter [mm], W:Width [mm], L:Length [mm], S=(bright spot size)/(dot size)

DATE DOCUMENT CONTROL SECTION

						TITLE		FLC26XGC6R	
						DRAW. NO.		Tech Bes LCD-00185	
						CUST.			
EDIT	DATE	DESIG.	CHECK	APPR.	DESCRIPTION	FUJITSU DISPLAY TECHNOLOGIES CORPORATION		23 /	
DESIG.			CHECK		APPR.				

TENTATIVE

### 13. ENVIRONMENTAL SPECIFICATIONS

Table 13-1 show the environmental specifications.

**Table 13-1 Environmental specifications**

Item	Condition		Remark
Temperature	Operation	0~50°C	Temperature on surface of LCD panel (display area.)
	Storage	-20~60°C	
Humidity	Operation	20~85%RH	Maximum wet-bulb temperature should not exceed 29°C. No condensation.
	Storage	5~85%RH	
Vibration	Operation	10~500Hz, Sweep / 20minute, 2G, 2 hours for each X, Y and Z directions.	For single module without package.
Shock	Non-operation	15G, 6ms, 1time each ±X, ±Y and ±Z directions.	

NOTE: Table 13-2 and Figure 13-1 show the shock resistance standard when module is packaged.

**Table 13-2 Shock resistance standard when module is packaged**

Dropping location	Dropping height	Count
A ~ J	60cm	1 time

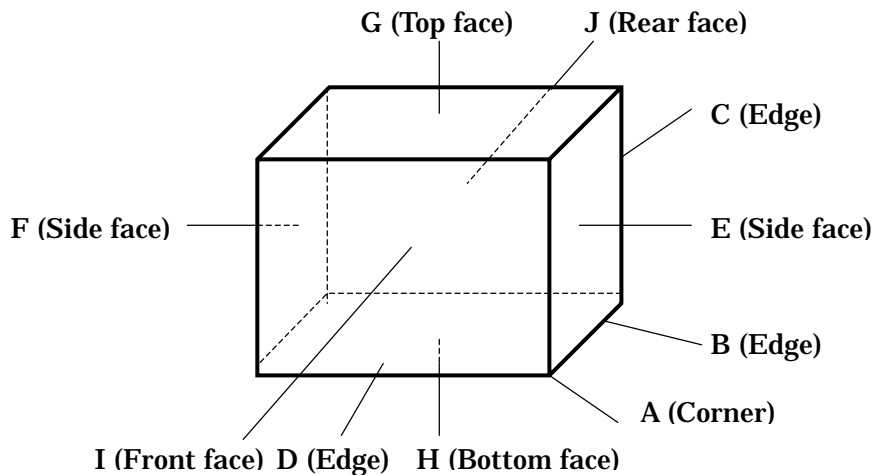

DOCUMENT CONTROL SECTION

						TITLE		FLC26XGC6R	
						DRAW. NO.			CUST.
						Tech Bes LCD-00185			
EDIT	DATE	DESIG.	CHECK	APPR.	DESCRIPTION		FUJITSU DISPLAY TECHNOLOGIES CORPORATION		24 /

### 14. INDICATIONS

This module has the following indications.

- (1) Product name : LCD unit
- (2) Model Number : FLC26XGC6R
- (3) Product Drawing Number : NA19026-C451
- (4) Manufacturing Number : **2 5 0 0 0 1**

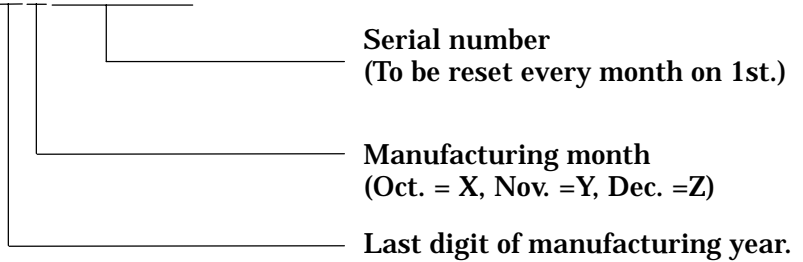

- (5) Version number : **01A** (Example)  
 -1st 2 digits "01" means operational version.  
 -3rd alphabet means functional version.
- (6) Manufacturer Country Name : MADE IN JAPAN
- (7) Company Name : FUJITSU DISPLAY TECHNOLOGIES CORP.
- (8) Disposal method of cold-cathode tubes. (See Figure 14-1)

· THIS TFT COLOR LCD CONTAINS COLD CATHODE FLUORESCENT LAMPS. PLEASE FOLLOW LOCAL ORDINANCES OR REGULATIONS FOR ITS DISPOSAL.  
 · 当該液晶ディスプレイユニットには蛍光管が組み込まれていますので、地方自治体の条例または規則に従って廃棄して下さい。

**Figure 14-2**

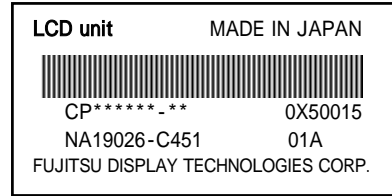

**Figure 14-1 Product Label (Example)**

### 15. PACKAGING

Packaging spec. is specified separately in the packaging specification.  
 \*This spec. is based on FDTC's original oversea packing specification against dropping damage.

DOCUMENT CONTROL SECTION

						TITLE	
						FLC26XGC6R	
						DRAW. NO.	
						Tech Bes LCD-00185	
						CUST.	
EDIT	DATE	DESIG.	CHECK	APPR.	DESCRIPTION		
DESIG.			CHECK		FUJITSU DISPLAY TECHNOLOGIES CORPORATION		
						25 /	25 /

TENTATIVE

16.WARRANTY

The warranty period is one year after shipping. Products which fail during this period are repaired or replaced without charge, unless the failure is caused by user.

17.PRECAUTIONS

Adhere to the following precautions to use this LCD module properly.

(1) Fail safe design

LCD module has an inherent chance of failure. Customers must protect against injury, damage or loss from such failures by incorporating safety design measures into your facility and equipment such as redundancy, fire protection, and prevention of over-current levels and other abnormal operating conditions.

(2) Handling of LCD panel

LCD panel is mounted rear side of LCD module.

Do not apply any strong mechanical shock to the LCD module.

Since the LCD panel is made of glass, excessive shock may damage the panel or cause a malfunction.

Do not press hard on the rear side of LCD module.

In the LCD panel, the gap between two glass plates is kept perfectly even to maintain display properties and reliability. The hard pressure on the LCD panel may cause the following problems.

- Ununiformity of color
- Disorder of orientation of liquid crystal

Problem returns to normal condition after a while. Problem returns to normal condition by turning the power off and turning on again. However these operations should be avoided to insure reliability.

Precaution for not damaging the front light

· Since the surface of front light consists of the fine prism form, dent and dirt soil may cause deterioration of display quality.

· ***!Do not touch the display surface.***

· On handling, please put on conductive gloves, and don't touch the screen.

Do not place or contact objects on the display surface.

This may make some parts of the LCD module distorted and the quality of display may deteriorate.

(3) Handling of LCD module

Do not pull the cold-cathode tube cable strongly.

If the cable is pulled with the strength of 2kgf or more, the cable may be damaged or may lose reliability.

DATE DOCUMENT CONTROL SECTION

						TITLE		FLC26XGC6R	
						DRAW. NO.			CUST.
						Tech Bes LCD-00185			
EDIT	DATE	DESIG.	CHECK	APPR.	DESCRIPTION				FUJITSU DISPLAY TECHNOLOGIES CORPORATION
DESIG.			CHECK			APPR.		26 /	

TENTATIVE

**Assemble the module into user's system in a dust free environment.**

Visible dirt between the protective board and LCD module may cause deterioration in display quality.

Conductive foreign matter adheres to the module may cause failures.

**Take anti-electrostatic measures for assembling the module.**

Since the LCD module contains CMOS-ICs, the following points should be observed.

- For assembling the module, operator should be grounded and wear cotton or conductive gloves.
- Floor of work area and work table to assemble the LCD module should be covered with electrostatic shielding in order to discharge static electricity via an earth wire.
- If necessary, ground operation tools (soldering iron, radio pliers, tweezers, etc.).
- Do not take the module out of the conductive bag until the module is assembled.
- Do not assemble the module under low humidity (50%RH or less).

**Do not disassemble or remodel the LCD module.**

Disassembly or remodeling of the LCD module may result in malfunctions or deterioration in the display quality and reliability.

**(4) Precautions in regards of operating the LCD module**

**Adhere to the specified power supply sequence.**

If not followed, the CMOS-IC may cause a latch-up, or DC voltage may be applied to the liquid crystal, which cause a failure or serious deterioration in display quality.

**Do not operate the LCD module when condensation occurs.**

If the LCD module is operated when condensation is on the terminals of the LCD panel, the terminals cause electrochemical reaction, and may reach disconnection. Condensation easily occurs especially when the module is moved from cold environment to warm environment.

**The following troubles occur when the LCD module is not used under recommended temperature.**

- Operation under high temperature(>50 ): Display colors shift to blue.
- Storage under high temperature(>60 ): The polarizer film deteriorates and contrast decreases.
- Operation under low temperature(< 0 ): The response speed decreases considerably.
- Storage under low temperature(<-20 ): The liquid crystal may solidify and become damaged.

**Be sure to input the control signals at the correct timing.**

If control signals (DCLK, ENAB) are not input, or if the timing is out of the specified timing, DC voltage may be applied to the liquid crystal and, as a result, cause image sticking or deterioration of contrast.

**The Strong Moire Stripe will be appeared on Special Pattern.**

The strong moiré stripe will be appeared on horizontal stripe display.

DATE DOCUMENT CONTROL SECTION

						TITLE		FLC26XGC6R	
						DRAW. NO.		Tech Bes LCD-00185	
								CUST.	
EDIT	DATE	DESIG.	CHECK	APPR.	DESCRIPTION				
DESIG.			CHECK		APPR.	FUJITSU DISPLAY TECHNOLOGIES CORPORATION		27 /	

TENTATIVE

(5) Precautions in regards of designing module mounting

**Excessive force should not be applied to the screen or the rear side of the LCD module.**  
 Excessive pressure on the screen caused by the installation of the LCD module may deteriorate display quality and reliability.  
 Since panel at the rare side of this LCD module is made from glass, brightness uniformity and the reliability of CCFT may decrease if the pressure is applied to the frontlight module.

**Avoid twisting and bending the LCD module.**  
 Excessive twist and bend may damage display quality and reliability.

**Avoid extending the power cable between the LCD module and inverter.**  
 This may cause the frontlight to flicker or not to light.

**Keep the frontlight cable apart from the metal enclosure of the LCD module.**  
 When frequency current for frontlight driving leak to the metal enclosure, the desired brightness may not be assured.

**Take countermeasure against electromagnetic interference of digitizer unit.**  
 The noise, which is occurred from transfer and inductance for power supply, affects electromagnetic induction sensor module. It is recommended to use the transfer and inductance that don't leak out magnetic flux. Please don't mount magnetic flux of transfer and coil right angled to sensor board.

**Mount the protect board on display screen.**  
 The surface of frontlight is prism form. Make the circumstance that the surface cannot be touched.

(6) Storage method

**Do not store the LCD module in an atmosphere of organic solvent or corrosive gas.**  
 In an organic solvent atmosphere, the polarizer film discolors and display quality deteriorates.  
 In a corrosive gas environment, various parts of the module may corrode or deteriorate.

**Store the LCD module in a FDTC package.**  
 At storing, FDTC packages can be stacked up to 4 boxes.  
 The LCD module is in an anti-static bag. Keep the module in that status.

**The LCD module is recommended to be stored in humidity controlled, cool and dark locations.**  
 Recommended storage environment  
 ·Place : Dark (avoid direct sunlight)  
 ·Temperature : 10 ~ 35  
 ·Humidity : 50 ~ 60%RH

Note) If the module is left in an environment of 60 and above for a long period of time, optical characteristics may deteriorate.

(7) Disposal Method

**LCD module**  
 The components of this LCD module can be grouped into metal, resin, glass and so on. As the frontlight contains CCFL which includes mercury, it must be disposed according to the local ordinance or regulations.

**Package**  
 All the packages are made of recyclable papers except the anti-ESD bag.

DOCUMENT CONTROL SECTION

DATE

						TITLE		FLC26XGC6R	
						DRAW. NO.			CUST.
						Tech Bes LCD-00185			
EDIT	DATE	DESIG.	CHECK	APPR.	DESCRIPTION				FUJITSU DISPLAY TECHNOLOGIES CORPORATION
									28 /

TENTATIVE

**(8) Others**

**If the LCD panel is damaged, do not inhale and do not swallow the liquid crystal.**  
If the liquid crystal adhere to the body or cloths, wash it off with soap immediately.  
Follow regular precautions for electronic components.

**Flux residue on the printed circuit board is harmless to the quality and reliability of LCD module.**

FDTC has adopted non-wash technology on module assembly process.

**18. PRECAUTIONS FOR USE**

This Product is designed, developed and manufactured as contemplated for general use, including without limitation, general office use, personal use, household use, and ordinary industrial use, but is not designed, developed and manufactured as contemplated for use accompanying fatal risks or dangers that, unless extremely high safety is secured, could lead directly to death, personal injury, severe physical damage or other loss (hereinafter "High Safety Required Use"), including without limitation, nuclear reaction control in nuclear facility, aircraft flight control, air traffic control, mass transport control, medical life support system, missile launch control in weapon system. If customer's product possibly falls under the category of High Safety Required Use, please consult with our sales representatives in charge before such use. In addition, FDTC shall not be liable against the customer and/or any third party for any claims or damages arising in connection with the High Safety Required Use of the Product without permission.

**19. MISCELLANEOUS**

Specifications of the TFT-LCD panel and other components used in the LCD module are subject to change. Both parties shall discuss together before change.

If any doubt is raised in the content of the specifications, both parties shall discuss and make best effort for the agreement.

DATE DOCUMENT CONTROL SECTION

						TITLE <b>FLC26XGC6R</b>	
						DRAW. NO. <b>Tech Bes LCD-00185</b>	
						CUST.	
EDIT	DATE	DESIG.	CHECK	APPR.	DESCRIPTION	FUJITSU DISPLAY TECHNOLOGIES CORPORATION	
DESIG.			CHECK		APPR.	29 /	

1

2

3

4

5

6

7

8

A

B

C

D

A

B

C

D

E

F

235.6±0.7  
231.8±0.4  
229.3±0.5

35±5

5.5±0.5  
1.8  
0.4

5.5±0.5  
1.8  
0.4

8.5  
3.0

117.1±0.5 (Active Area Center)  
217.2±0.4 (Bezel Opening)  
210.432±0.5 (Active Area)

13.2

CN-2

8.2  
5.0

Ø2.0  
Ø3.0

Ø3.0

1.6  
10.9

(53.2)

Ø0.8

173.2±0.7  
163.5±0.4 (Bezel Opening)  
160.0±0.4  
153.0±0.5  
143.0±0.4  
136.4±0.4  
157.824 (Active Area)

73.1±0.5 (Active Area Center)

Digitizer  
Control Board

CN-3

Active Area Center

136.4±0.5  
139.9±0.4  
153.9±0.4  
156.9±0.5

(111.3)

3.0  
0.2

Ø3.0

CN-1

Ø3.0

0.4  
1.8  
6.8

228.8±0.5  
231.55±0.5  
234.8±0.7

0.4  
1.8  
6.8

DATE DOCUMENT CONTROL SECTION

TENTATIVE

Front View

						TITLE FLC26XGC6R	
						DRAW. NO. Tech Bes LCD-00185	
						CUST.	
EDIT.	DATE	DESIG.	CHECK	DESCRIPTION		FUJITSU DISPLAY TECHNOLOGIES CORPORATION	
DESIG.			CHECK	APPR.		30/	

1

2

3

5

6

7

93.04 FDNC:3901:3

1

2

3

4

5

6

7

8

A

B

C

D

A

B

C

D

E

F

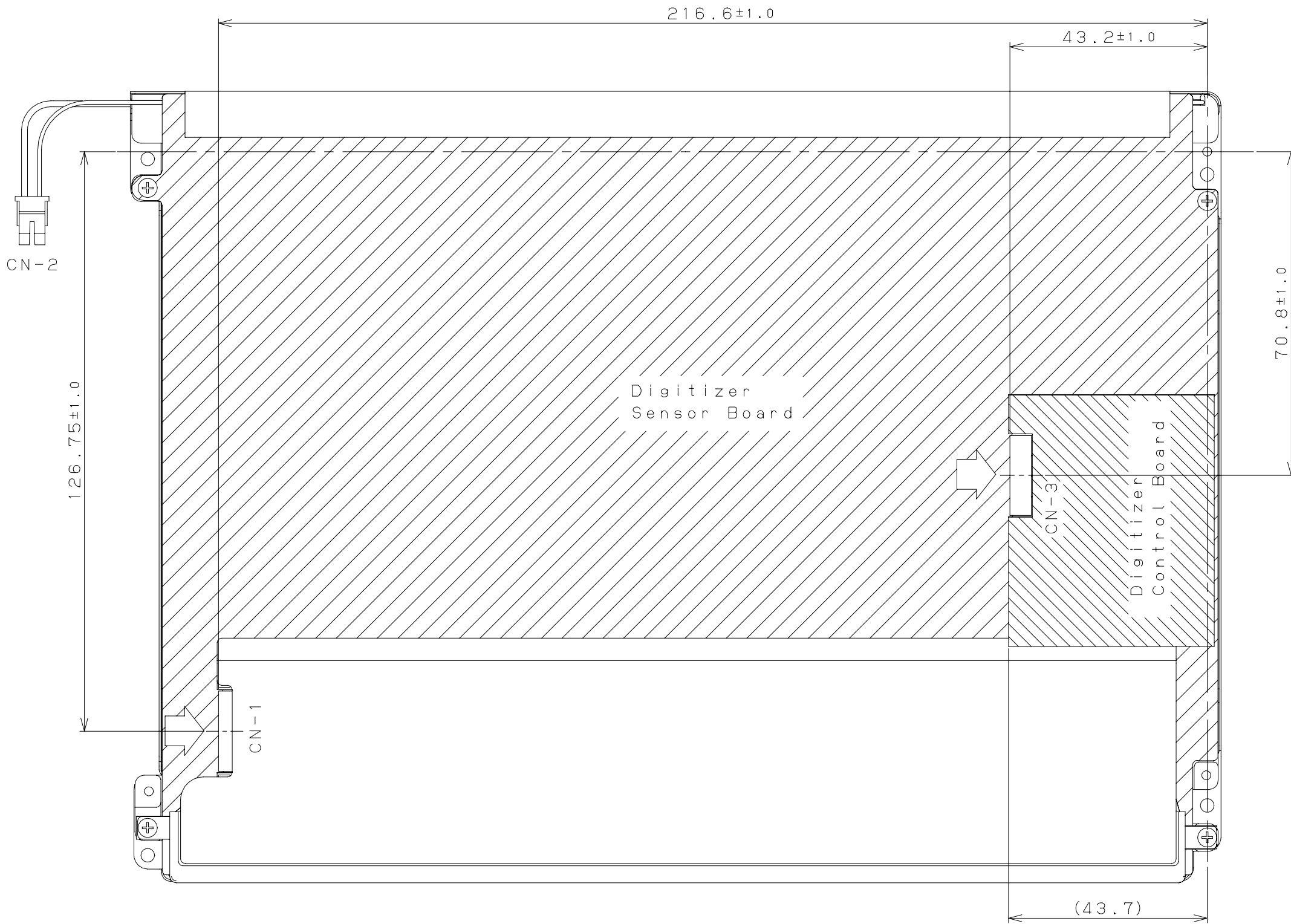

DATE

DOCUMENT CONTROL SECTION

↑

TENTATIVE

Rear View

						TITLE FLC26XGC6R	
						DRAW. NO. Tech Bes LCD-00185	
						CUST.	
EDIT.	DATE	DESIG.	CHECK	DESCRIPTION		FUJITSU DISPLAY TECHNOLOGIES CORPORATION	
DESIG.			CHECK		APPR.	SHEET 31 / 31	

1

2

3

4

5

6

7

93.04 FDNC:3901-3