

mass integrated

global part distribution • product lifecycle partner
excess inventory management • value-ad service provider



Data sheet provided by Mass Integrated

massintegrated.com • displayalliance.com

Please call +1.978.465.6190
Email: sales@massintegrated.com



ISO 9001: 2008

Mass Integrated complies with all DMCA takedown notices. Please send a formal DMCA Takedown Notice to Mass Integrated Systems, Inc. • 18 Henry Graf Jr. Road, Unit 1 • Newburyport, MA 01950.



Specification

G085VW01 V0

Version August 2009

Contents

1. Operating Precautions	4
2. General Description	5
2.1 Display Characteristics	5
2.2 Optical Characteristics	6
3. Functional Block Diagram	9
4. Absolute Maximum Ratings.....	10
4.1 Absolute Ratings of TFT LCD Module.....	10
4.2 Absolute Ratings of Environment.....	10
5. Electrical Characteristics.....	11
5.1 TFT LCD Module	11
5.2 Backlight Unit	12
6. Signal Characteristic.....	13
6.1 Pixel Format Image.....	13
6.2 Signal Description	14
6.3 Scanning Direction.....	16
6.4 Interface Timing	17
6.5 Power ON/OFF Sequence	20
7. Connector & Pin Assignment	21
7.1 TFT LCD Signal (CN1): LCD Connector	21
7.2 LED Backlight Unit (CN2): LED Driver Connector.....	21
7.3 LED Light Bar Input Connector (CN3):	22
8. Reliability Test Criteria.....	22
9. Mechanical Characteristics	23
9.1 LCM Front View	23
9.2 LCM Rear View	24
10. Label and Packaging.....	25
10.1 Shipping Label (on the rear side of TFT-LCD display)	25
10.2 Carton Package	25
11 Safety.....	25
11.1 Sharp Edge Requirements.....	25
11.2 Materials.....	25
11.3 Capacitors	25
11.4 National Test Lab Requirement.....	25



Record of Revision

Version and Date	Page	Old description	New Description
0.0 2009/08/28	All	First Edition	

1. Operating Precautions

- 1) Since front polarizer is easily damaged, please be cautious not to scratch it.
- 2) Be sure to turn off power supply when inserting or disconnecting from input connector.
- 3) Wipe off water drop immediately. Long contact with water may cause discoloration or spots.
- 4) When the panel surface is soiled, wipe it with absorbent cotton or soft cloth.
- 5) Since the panel is made of glass, it may be broken or cracked if dropped or bumped on hard surface.
- 6) To avoid ESD (Electro Static Discharge) damage, be sure to ground yourself before handling TFT-LCD Module.
- 7) Do not open nor modify the module assembly.
- 8) Do not press the reflector sheet at the back of the module to any direction.
- 9) In case if a module has to be put back into the packing container slot after it was taken out from the container, do not press the center of the LED Reflector edge. Instead, press at the far ends of the LED Reflector edge softly. Otherwise the TFT Module may be damaged.
- 10) At the insertion or removal of the Signal Interface Connector, be sure not to rotate nor tilt the Interface Connector of the TFT Module.
- 11) After installation of the TFT Module into an enclosure (Notebook PC Bezel, for example), do not twist nor bend the TFT Module even momentarily. At designing the enclosure, it should be taken into consideration that no bending/twisting forces are applied to the TFT Module from outside. Otherwise the TFT Module may be damaged.
- 12) Small amount of materials having no flammability grade is used in the LCD module. The LCD module should be supplied by power complied with requirements of Limited Power Source (IEC60950 or UL1950), or be applied exemption.
- 13) Severe temperature condition may result in different luminance, response time.
- 14) Continuous operating TFT-LCD Module under high temperature environment may accelerate LED light bar exhaustion and reduce luminance dramatically.
- 15) The data on this specification sheet is applicable when LCD module is placed in landscape position.
- 16) Continuous displaying fixed pattern may induce image sticking. It is recommended to use screen saver or shuffle content periodically if fixed pattern is displayed on the screen.

2. General Description

This specification applies to the 8.5 inch color TFT LCD module G085VW01 V0.

G085VW01 V0 designed with wide viewing angle; wide operating temperature and long life LEDs backlight is well suited to be the display units for Industrial Applications.

LED driving board for backlight unit is included in this panel and the structure of the LED units is replaceable.

G085VW01 V0 is built in timing controller and CMOS interface.

The screen format is intended to support the WVGA (800(H) x 480(V)) screen and 262k colors (RGB 6-bits).

G085VW01 V0 is a RoHS product.

2.1 Display Characteristics

The following items are characteristics summary on the table under 25 °C condition:

Items	Unit	Specifications
Screen Diagonal	[inch]	8.5 (215.5 mm)
Active Area	[mm]	184.8(H) x 110.88(V)
Pixels H x V		800x3(RGB) x 480
Pixel Pitch	[mm]	0.231x 0.231
Pixel Arrangement		R.G.B. Vertical Stripe
Display Mode		TN, Normally White
Nominal Input Voltage VDD	[Volt]	3.3 typ.
Typical Power Consumption	[Watt]	TBD
Weight	[Grams]	TBD
Physical Size	[mm]	210.0(W) x 134(H) x 10.0(D) (typ.)
Electrical Interface		CMOS I/F
Surface Treatment		Anti-glare, Hardness 3H
Support Color		262K(6-bit)
Temperature Range Operating Storage (Non-Operating)	[°C] [°C]	-30 to +85 (panel surface temperature) -30 to +85
RoHS Compliance		RoHS Compliance

2.2 Optical Characteristics

The optical characteristics are measured under stable conditions at 25°C (Room Temperature):

Item	Unit	Conditions	Min.	Typ.	Max.	Note
White Luminance	[cd/m ²]	I _F = 80mA (center point)	210	300	-	1
Uniformity	%	9 Points	70	75	-	1, 2, 3
Contrast Ratio			TBD	500	-	4
Response Time	[msec]	Rising	-	20	30	5
	[msec]	Falling	-	10	20	
	[msec]	Raising + Falling	-	30	50	
Viewing Angle	[degree]	Horizontal (Right) CR ≥ 10 (Left)	70	80	-	6
	[degree]		70	80	-	
	[degree]	Vertical (Upper) CR ≥ 10 (Lower)	65	80	-	
	[degree]		50	60	-	
Color / Chromaticity Coordinates (CIE 1931)		Red x	TBD	TBD	TBD	1
		Red y	TBD	TBD	TBD	
		Green x	TBD	TBD	TBD	
		Green y	TBD	TBD	TBD	
		Blue x	TBD	TBD	TBD	
		Blue y	TBD	TBD	TBD	
		White x	TBD	0.30	TBD	
		White y	TBD	0.32	TBD	
Color Gamut	%		-	50	-	1

Note 1: Measurement method

Equipment : Pattern Generator, Power Supply, Digital Voltmeter, Luminance meter (SR_3 or equivalent)

Aperture 1° with 50cm viewing distance

Test Point Center

Environment < 1 lux

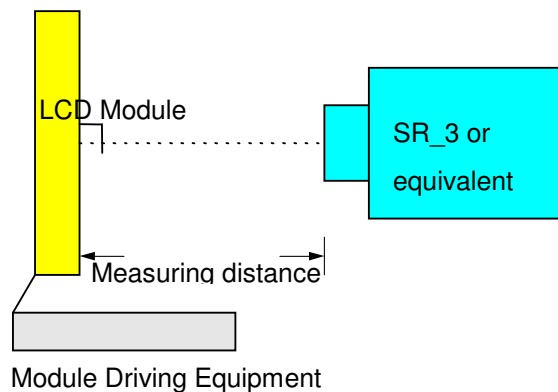

Note 2: Definition of 9 points position (Display active area : **184.8(H) x 110.88(V)**)

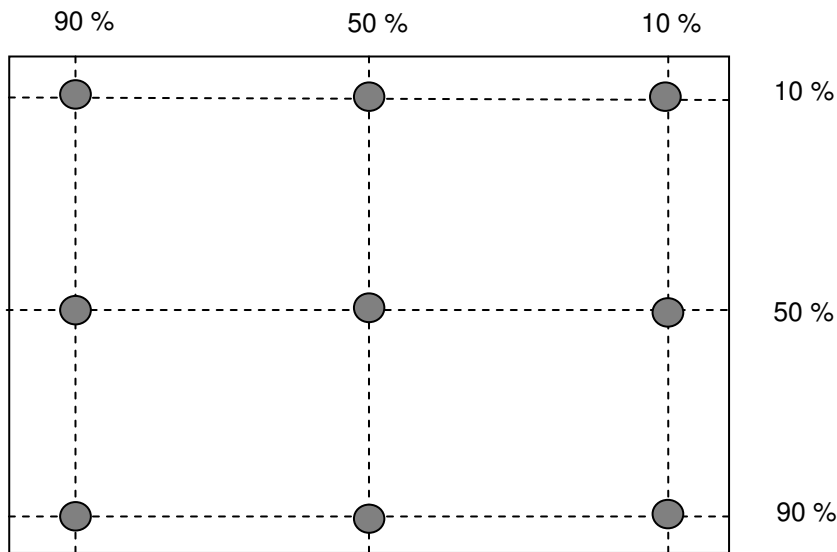

Note 3: The luminance uniformity of 9 points is defined by dividing the minimum luminance value by the maximum test point luminance

$$\delta_{w9} = \frac{\text{Minimum Brightness of nine points}}{\text{Maximum Brightness of nine points}}$$

Note 4 : Definition of contrast ratio (CR):

$$\text{Contrast ratio (CR)} = \frac{\text{Brightness on the "White" state}}{\text{Brightness on the "Black" state}}$$

Note 5: Definition of response time:

The output signals of photo detector are measured when the input signals are changed from "White" to "Black" (falling time) and from "Black" to "White" (rising time), respectively. The response time interval is between 10% and 90% of amplitudes. Please refer to the figure as below.

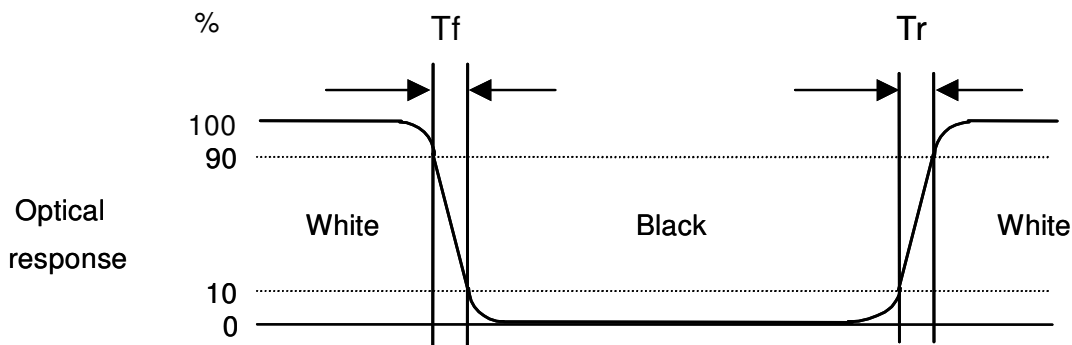

Note 6: Definition of viewing angle

Viewing angle is the measurement of contrast ratio ≥ 10 , at the screen center, over a 180° horizontal and 180° vertical range (off-normal viewing angles). The 180° viewing angle range is broken down as below: 90° (θ) horizontal left and right, and 90° (Φ) vertical high (up) and low (down). The measurement direction is typically perpendicular to the display surface with the screen rotated to its center to develop the desired measurement viewing angle.

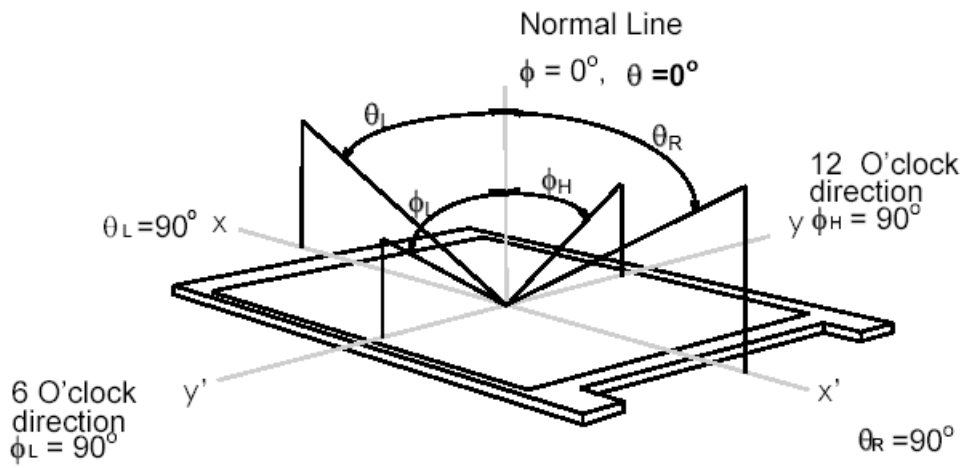

3. Functional Block Diagram

The following diagram shows the functional block of the 8.5 inch color TFT/LCD module:

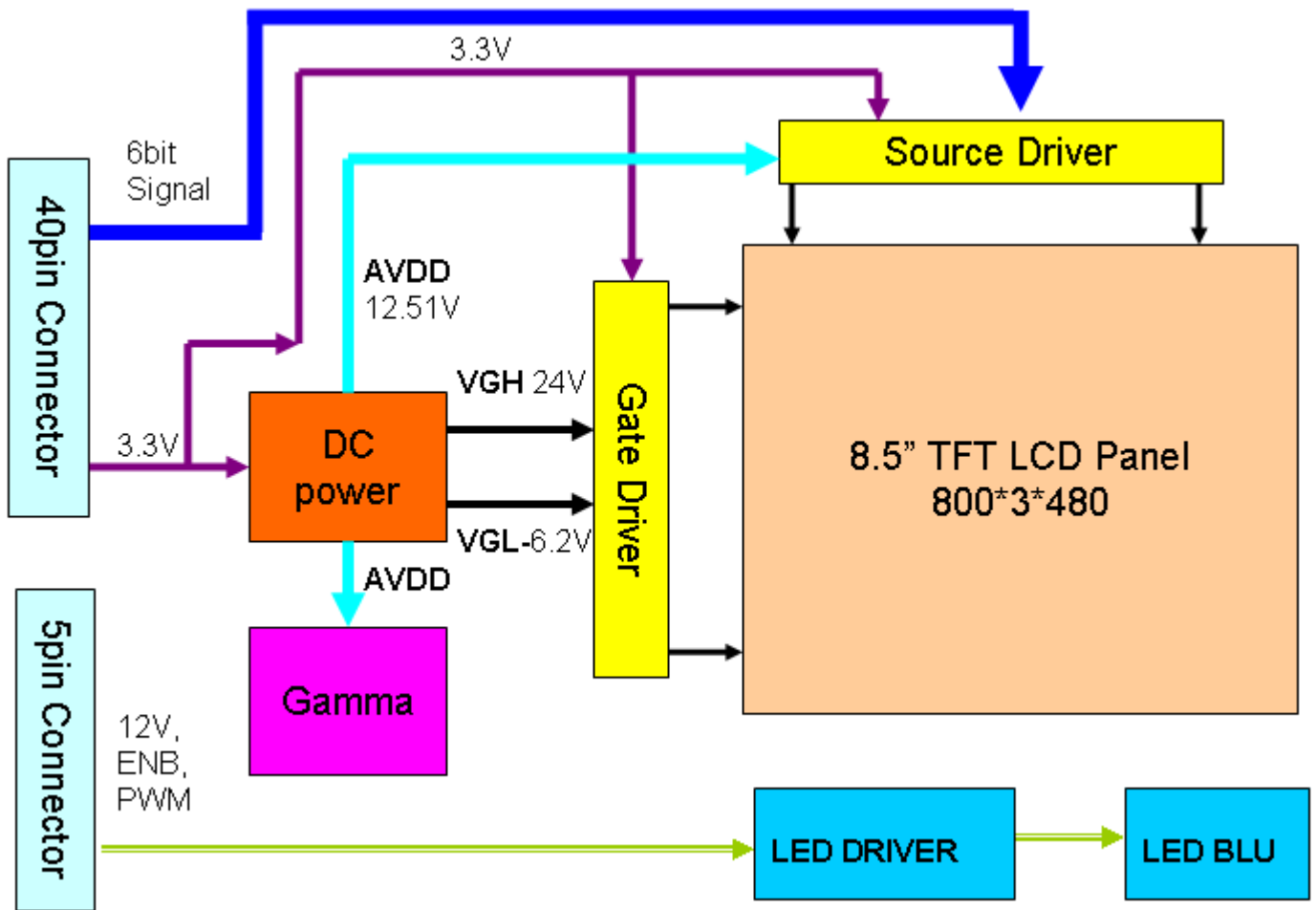

4. Absolute Maximum Ratings

4.1 Absolute Ratings of TFT LCD Module

Item	Symbol	Min	Max	Unit	Conditions
Logic/LCD Drive Voltage	VDD	-0.3	+3.6	[Volt]	

4.2 Absolute Ratings of Environment

Item	Symbol	Min	Max	Unit
Operating Temperature	TOP	-30	+85	[°C]
Operation Humidity	HOP	5	90	[%RH]
Storage Temperature	TST	-30	+85	[°C]
Storage Humidity	HST	5	90	[%RH]

Note: Maximum Wet-Bulb should be 39°C and no condensation.

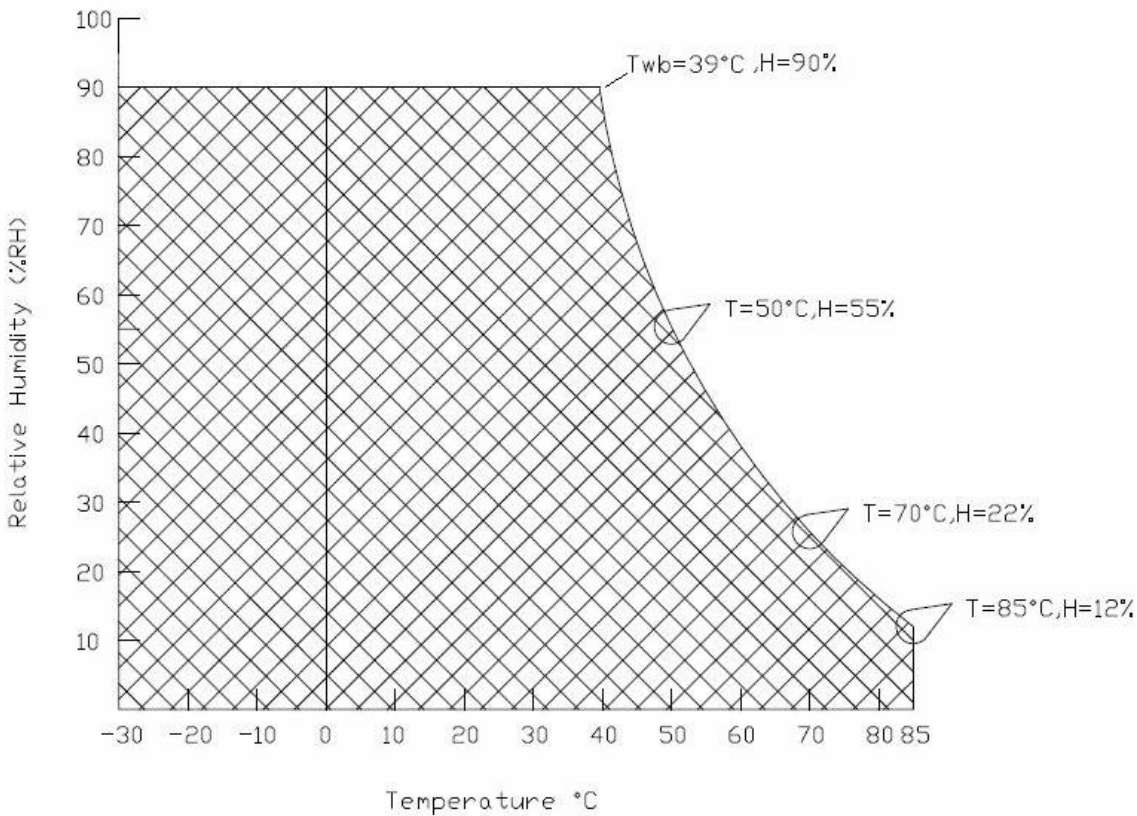

5. Electrical Characteristics

5.1 TFT LCD Module

5.1.1 Power Specification

Symbol	Parameter	Min	Typ	Max	Units	Remark
VDD	Logic/LCD Input Voltage	3.0	3.3	3.6	[Volt]	
I _{VDD}	LCD Input Current	-	TBD	-	[mA]	VDD=3.3V at 60 HZ, all Black Pattern
P _{VDD}	LCD Power consumption	-	TBD	-	[Watt]	VDD=3.3V at 60 HZ, all Black Pattern
I _{rush LCD}	LCD Inrush Current	-	-	1.5	[A]	Note 1; VDD=3.3V Black Pattern, Rising time=470us
VDD _{rp}	Allowable Logic/LCD Drive Ripple Voltage	-	-	100	[mV] p-p	VDD=3.3V at 60 HZ, all Black Pattern

Note 1: Measurement condition:

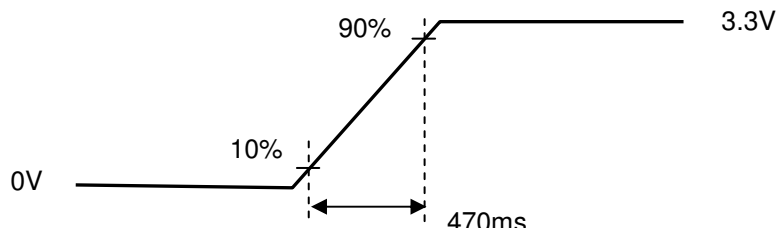
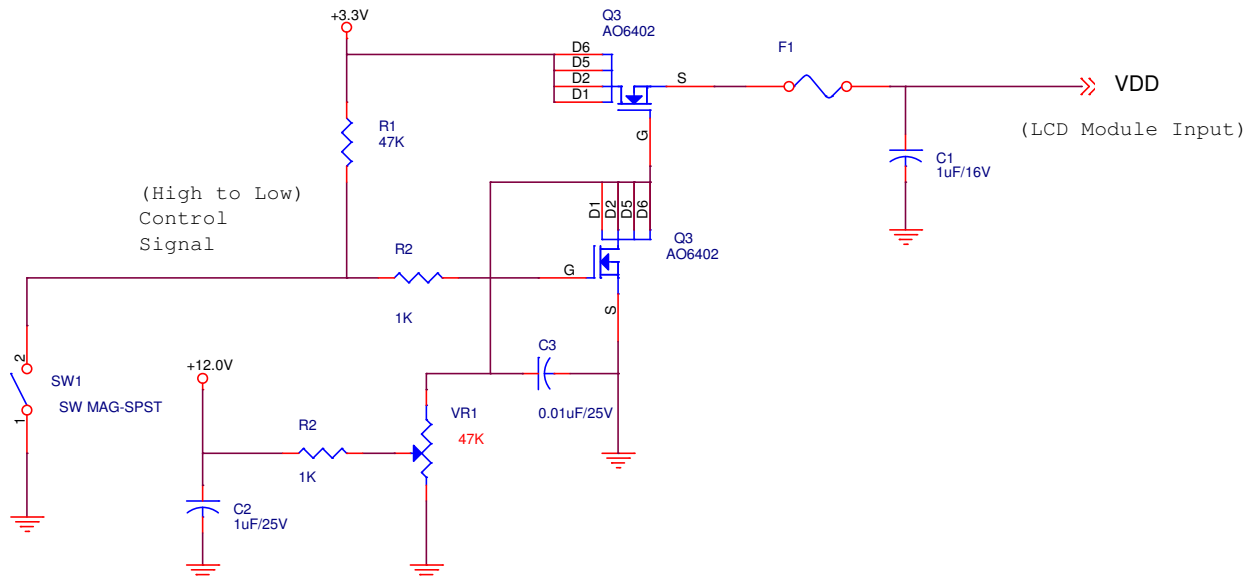

VDD rising time

5.2 Backlight Unit

5.2.1 Parameter guideline for LED backlight

Following characteristics are measured under a stable condition using an inverter at 25°C (Room Temperature):

Symbol	Parameter	Min.	Typ.	Max.	Unit	Remark
VCC	Input Voltage	10.8	12	12.6	[Volt]	
I_{VCC}	Input Current	-	0.25	-	[A]	100% PWM Duty
P_{VCC}	Power Consumption	-	3	-	[Watt]	100% PWM Duty
I_{rush LED}	Inrush Current	-	-	1.5	[A]	at rising time=470us
F_{PWM}	Dimming Frequency	200	-	20K	[Hz]	
	Swing Voltage	3	3.3	5.5	V	
	Dimming Duty Cycle	5	-	100	%	

Note 1: Ta means ambient temperature of TFT-LCD module.

Note 2: VCC, I_{VCC}, P_{VCC}, I_{rush LED} are defined for LED B/L.(100% duty of PWM dimming)

Note 3: I_F, V_F, P_{LED} are defined for LED Light Bar. There is one LED channel in back light unit.

Note 4: If G085VW01 V0 module is driven by high current or at high ambient temperature & humidity condition. The operating life will be reduced.

Note 5: Operating life means brightness goes down to 50% initial brightness. Minimum operating life time is estimated data.

6.2 Signal Description

Pin No.	Symbol	Description
1	GND	Ground
2	GND	Ground
3	CK	Clock signal for sampling each data signal
4	GND	Ground
5	GND	Ground
6	REV	Normal :OPEN/GND; Reverse :High
7	R0	RED data signal (LSB)
8	R1	RED data signal
9	R2	RED data signal
10	GND	Ground
11	R3	RED data signal
12	R4	RED data signal
13	R5	RED data signal (MSB)
14	GND	Ground
15	G0	GREEN data signal (LSB)
16	G1	GREEN data signal
17	G2	GREEN data signal
18	GND	Ground
19	G3	GREEN data signal
20	G4	GREEN data signal
21	G5	GREEN data signal (MSB)
22	GND	Ground
23	B0	BLUE data signal (LSB)
24	B1	BLUE data signal
25	B2	BLUE data signal
26	GND	Ground
27	B3	BLUE data signal
28	B4	BLUE data signal
29	B5	BLUE data signal (MSB)
30	GND	Ground

Pin No.	Symbol	Description
31	Hsync	Horizontal synchronous signal
32	GND	Ground
33	Vsync	Vertical synchronous signal
34	FGND	Frame Ground
35	ENAB	Data enable signal (signal to settle the horizontal display position)
36	Mode	Data input format select, NC/High: DE mode; Low: Sync mode.
37	VCC	+3.3V power supply
38	VCC	+3.3V power supply
39	VCC	+3.3V power supply
40	VCC	+3.3V power supply

6.3 Scanning Direction

The following figures show the image seen from the front view. The arrow indicates the direction of scan.

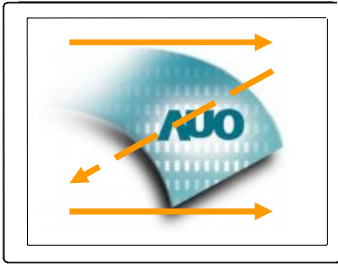

Fig. 1

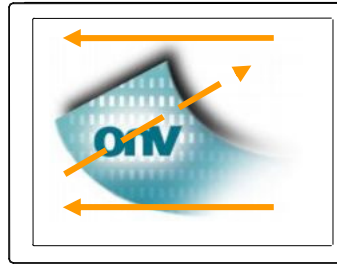

Fig. 2

Fig. 1 Normal scan (Pin6, GND or NC)

Fig. 2 Reverse scan (Pin6, High)

6.4 Interface Timing

6.4.1 Timing Characteristics

Customers could select the input data format through controlled the NC/High or Low of Pin 36.

DE Mode

Signal	Symbol	Min.	Typ.	Max.	Unit	Remark	
Clock frequency (DOTCLK)	$1/T_{\text{CLOCK}}$	31.95	33.26	34.6	MHz	Note1	
Horizontal Section	Period	T_H	888	928	1138	T_{CLOCK}	Note1
	Active	T_{HD}	800				
	Blanking	T_{HB}	88	128	338		
Vertical Section	Period	T_V	515	525	762	T_{LINE}	Note1
	Active	T_{VD}	480				
	Blanking	T_{VB}	35	45	282		

Note: 1. Frame rate is 60 Hz at 3.3V VCC.

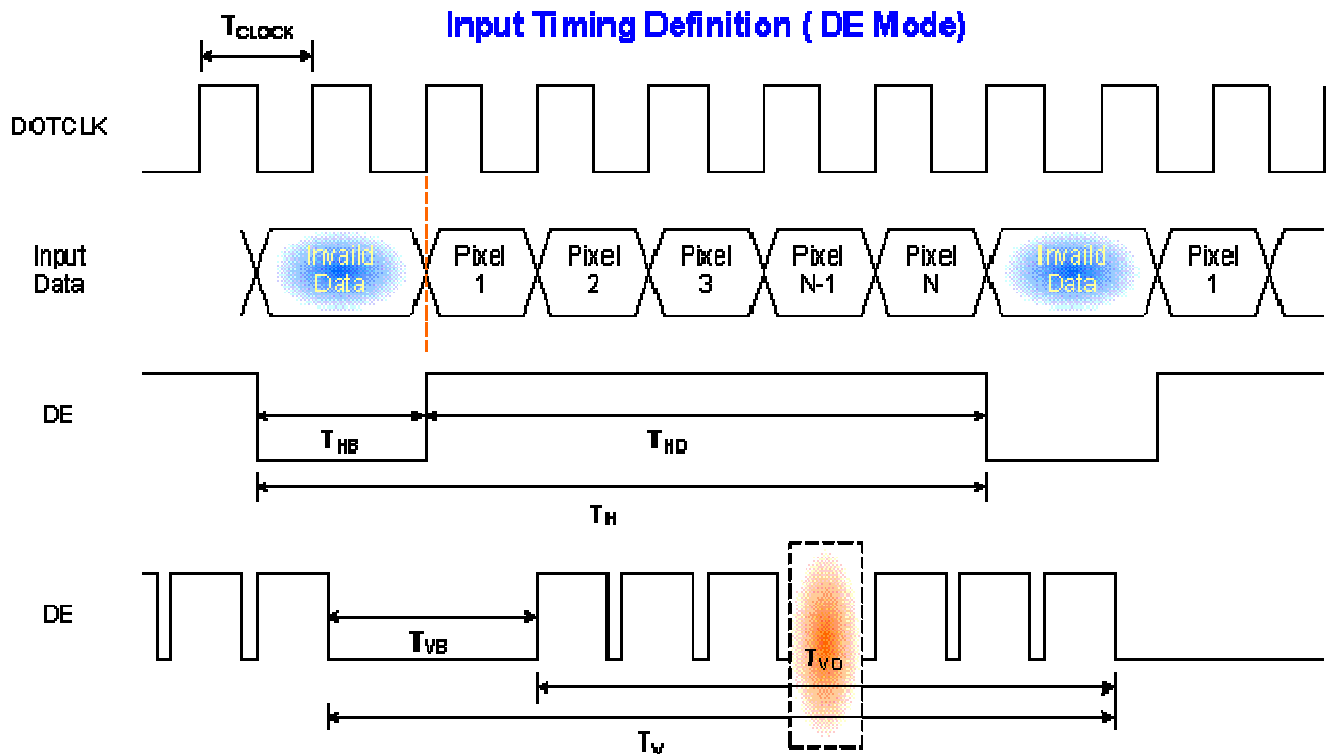

Sync Mode (HV Mode)

Parameter	Note	Symbol	Min.	Typ.	Max.	Unit	Note
Hsync	Period	th	-	928	-	clock	Note1
	Pulse width	thpw	1	48	-	clock	Note1
	Back porch	thb	-	88(fixed)	-	clock	Note1
	Front porch	thfp	-	40	-	clock	Note1
	Display period	thd	-	800	-	clock	Note1
Vsync	Period	tv	-	525	-	line	Note1
	Pulse width	tvpw	-	3	-	line	Note1
	Back porch	tvb	-	32(fixed)	-	line	Note1
	Front porch	tvfp	-	13	-	line	Note1
	Display period	thd	-	480	-	line	Note1

Note: 1. Frame rate is 60 Hz at 3.3V VCC.

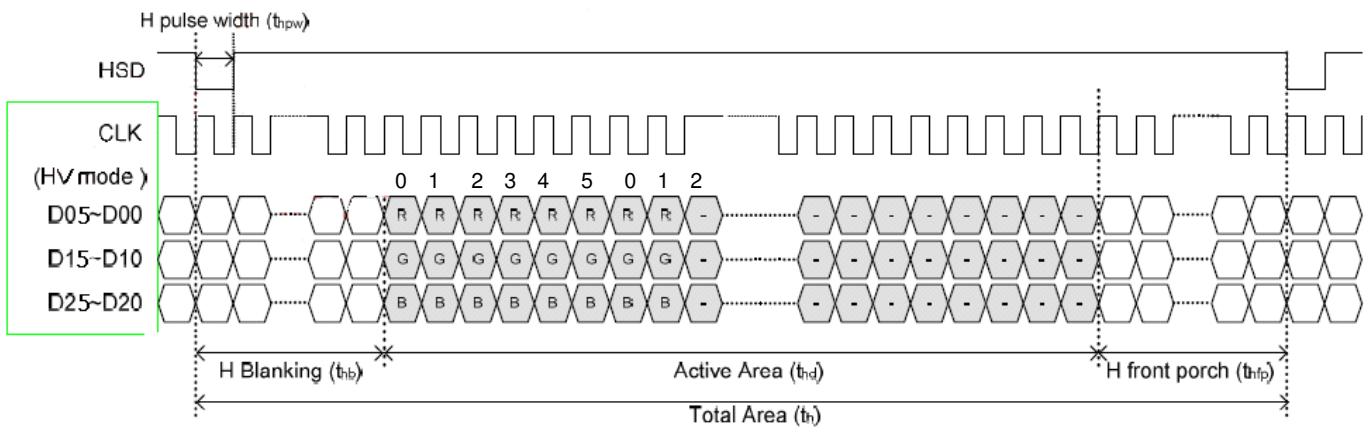
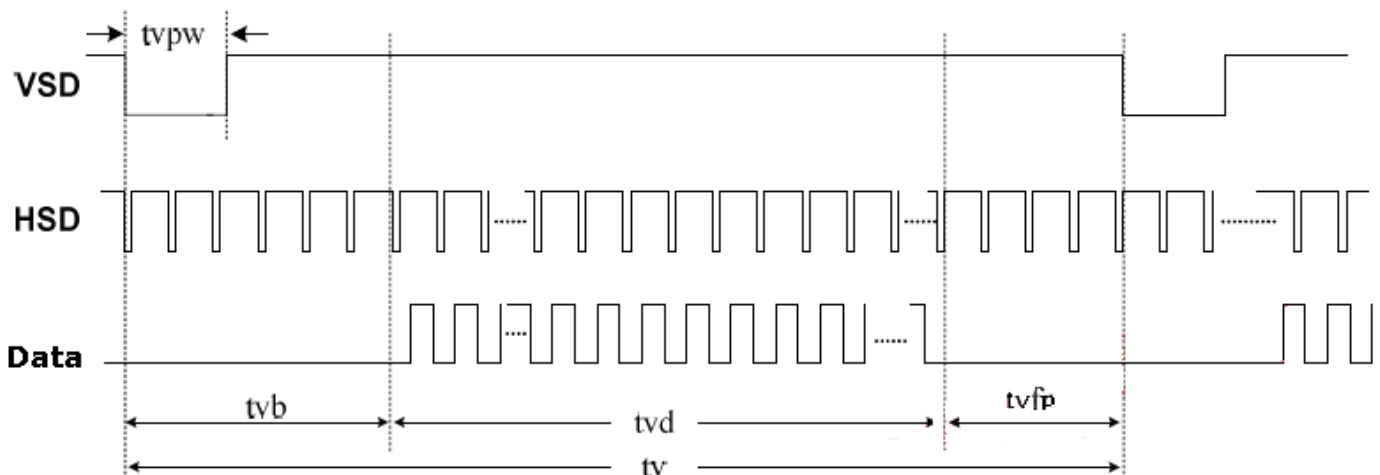
Horizontal input timing

Vertical input timing

6.4.2 Input timing setup/ hold time

Parameter	Note	Symbol	Min.	Typ.	Max.	Unit	Note
Clock	Frequency	1/Tc	31.95	33.26	34.6	MHz	Note1
	Clk pulse duty	Tcwh	40	50	60	%	Note1
	Clk cycle time	Tcph	25	-	-	ns	Note1
Data	Setup time	Tdsu	8	-	-	ns	Note1
	Hold time	Tdhd	8	-	-	ns	Note1
ENAB signal	Setup time	Tesu	8	-	-	ns	Note1
	Hold time	Tehd	8	-	-	ns	Note1
Hsync	Setup time	Thst	8	-	-	ns	Note1
	Hold time	Thhd	8	-	-	ns	Note1
Vsync	Setup time	Tvst	8	-	-	ns	Note1
	Hold time	Tvhd	8	-	-	ns	Note1

Note 1: Frame rate is 60 Hz at 3.3V VCC.

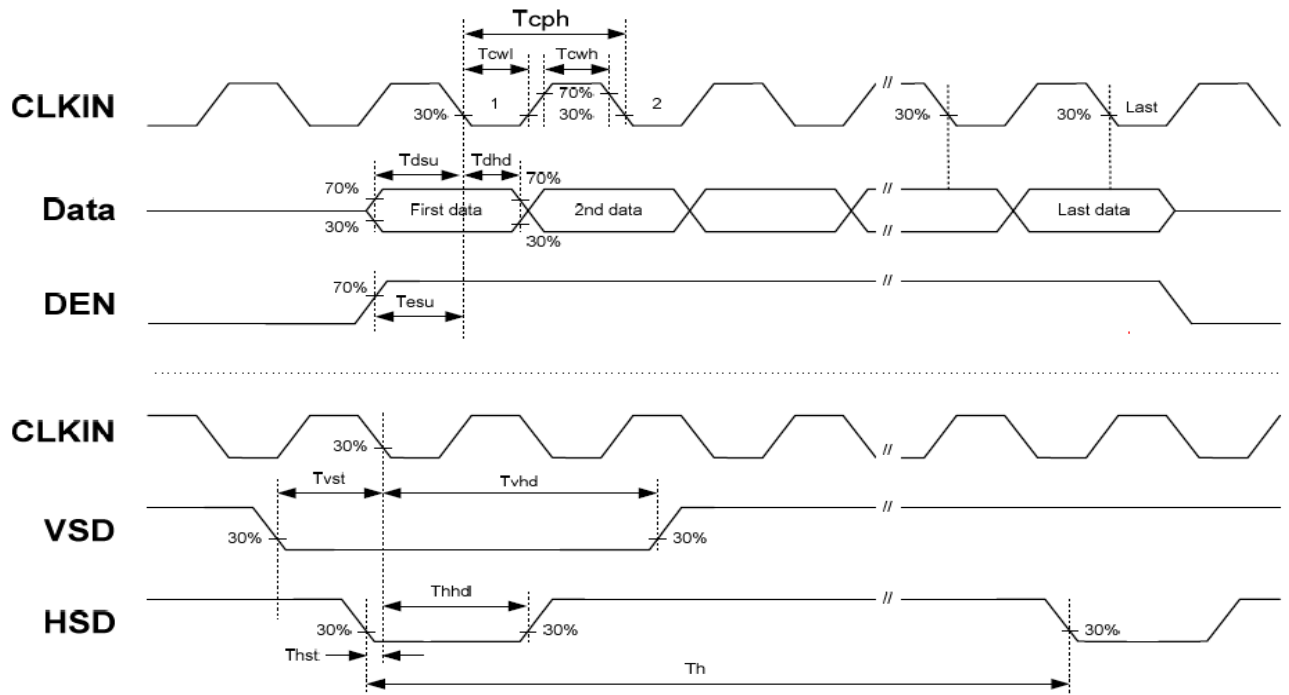
Input Clock and Data Timing Diagram



6.5 Power ON/OFF Sequence

VDD power and lamp on/off sequence is as below. Interface signals are also shown in the chart. Signals from any system shall be Hi-Z state or low level when VDD is off.

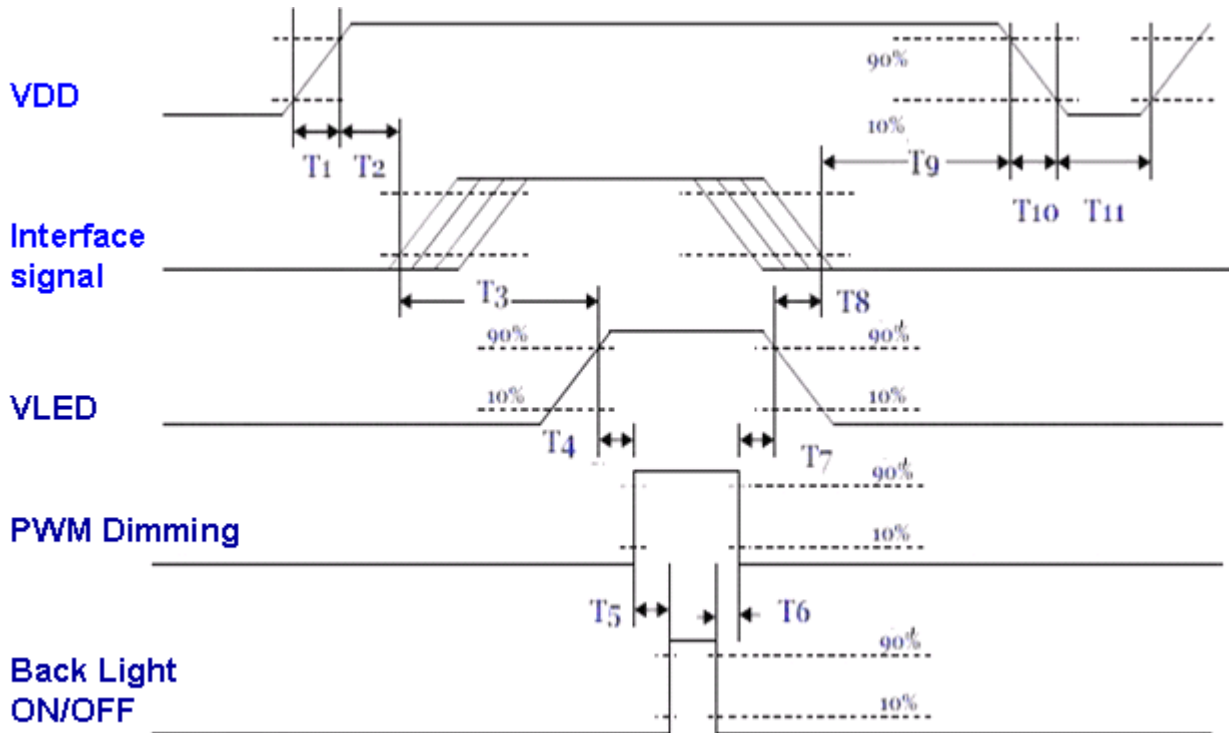

Power ON/OFF sequence timing

Parameter	Value			Units
	Min.	Typ.	Max.	
T1	0.5	-	10	[ms]
T2	0	-	50	[ms]
T3	200	-	-	[ms]
T4	10	-	-	[ms]
T5	10	-	-	[ms]
T6	0	-	-	[ms]
T7	10	-	-	[ms]
T8	100	-	-	[ms]
T9	0	16	50	[ms]
T10	-	-	10	[ms]
T11	1000	-	-	[ms]

The above on/off sequence should be applied to avoid abnormal function in the display. Please make sure to turn off the power when you plug the cable into the input connector or pull the cable out of the connector.

7. Connector & Pin Assignment

Physical interface is described as for the connector on module. These connectors are capable of accommodating the following signals and will be following components.

7.1 TFT LCD Signal (CN1): LCD Connector

Connector Name / Designation	Signal Connector
Manufacturer	STARTCONN or P-TWO
Connector Model Number	089H40-001100-G2-R or 196033-40041-3 or compatible.

7.2 LED Backlight Unit (CN2): LED Driver Connector

Connector Name / Designation	Lamp Connector
Manufacturer	Entery
Connector Model Number	3808K-F05N-02R or compatible.
Mating Model Number	H208K-P05N-02B or compatible.

Pin #	Symbol	Pin Description
1	VLED	12V Power Supply
2	GND	GND
3	ENB	LED BLU on/off control
4	PWM	Pulse width modulation for brightness of BLU control
5	NC	Don't connection

7.3 LED Light Bar Input Connector (CN4):

Connector Name / Designation	Lamp Connector
Manufacturer	Entery
Connector Model Number	H208K-P02N-02B or compatible.
Mating Model Number (CN3)	3808K-F02N-02R or compatible.

Pin #	Symbol	Pin Description
1	Vout	Positive voltage to connection LED BLU
2	FB1	Constant current feedback signal 1

8. Reliability Test Criteria

Items	Required Condition	Note
Temperature Humidity Bias	40°C/90%,300 hours	
High Temperature Operation	85°C ,300 hours	
Low Temperature Operation	-30°C ,300 hours	
Hot Storage	85°C ,300 hours	
Cold Storage	-30°C ,300 hours	
Thermal Shock Test	-20°C/30 min ,60°C/30 min ,100cycles	
Shock Test (Non-Operating)	50G,20ms,Half-sine wave,(±X, ±Y, ±Z)	
Vibration Test (Non-Operating)	1.5G, (10~200Hz, P-P) 30 mins/axis (X, Y, Z)	
On/off test	On/10 sec, Off/10 sec, 30,000 cycles	
ESD	Contact Discharge: ± 8KV, 150pF(330Ω) 1sec, 8 points, 25 times/ point Air Discharge: ± 15KV, 150pF(330Ω) 1sec, 8 points, 25 times/ point	Note 1
EMI	30-230 MHz, limit 40 dBu V/m, 230-1000 MHz, limit 47 dBu V/m	

Note1: According to EN61000-4-2, ESD class B: Some performance degradation allowed. No data lost
 . Self-recoverable. No hardware failures.

9. Mechanical Characteristics

9.1 LCM Front View

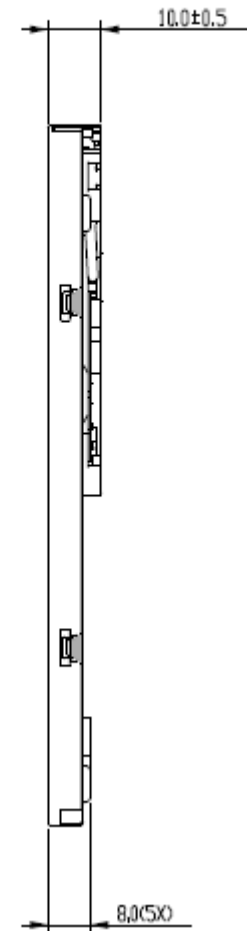
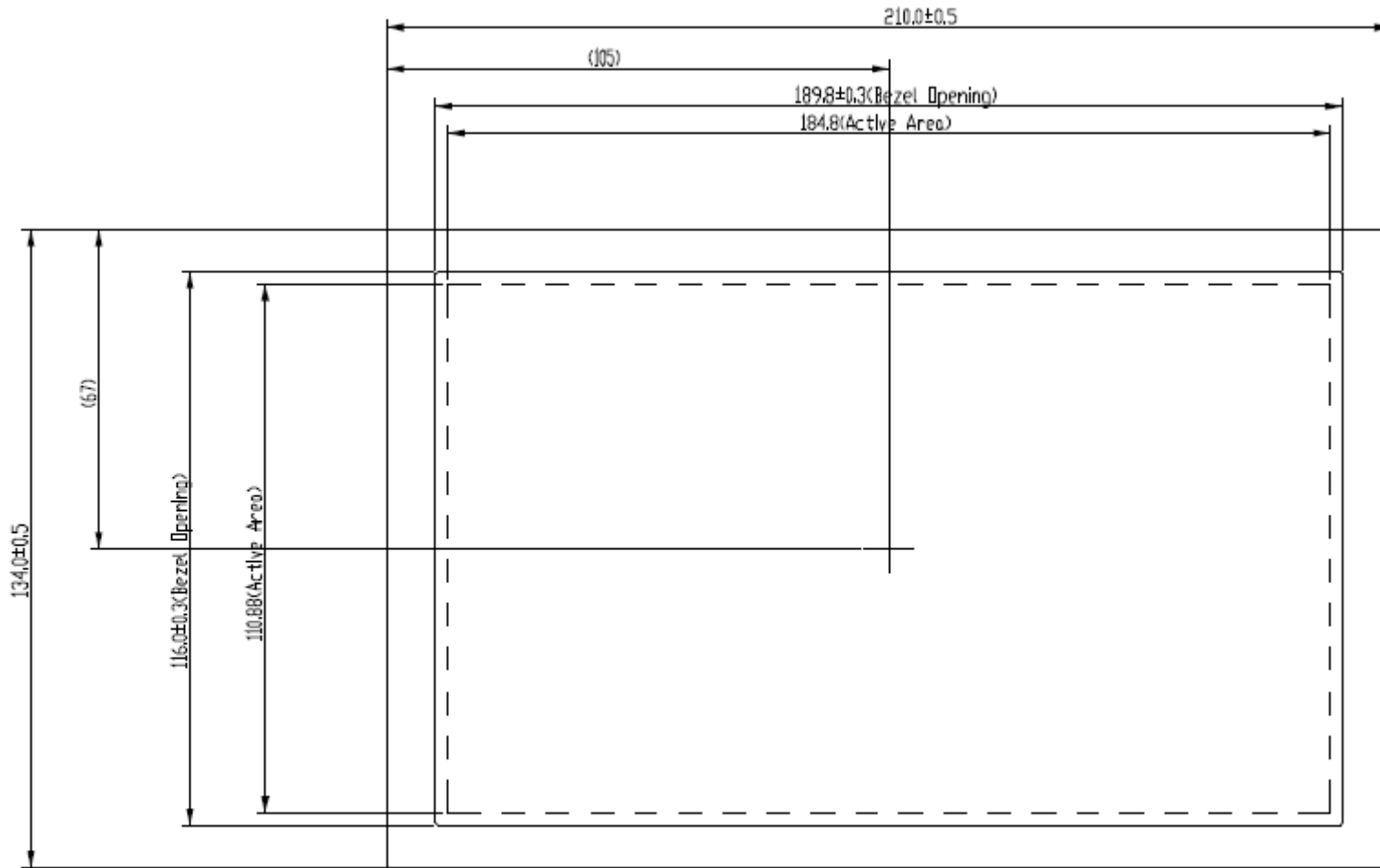

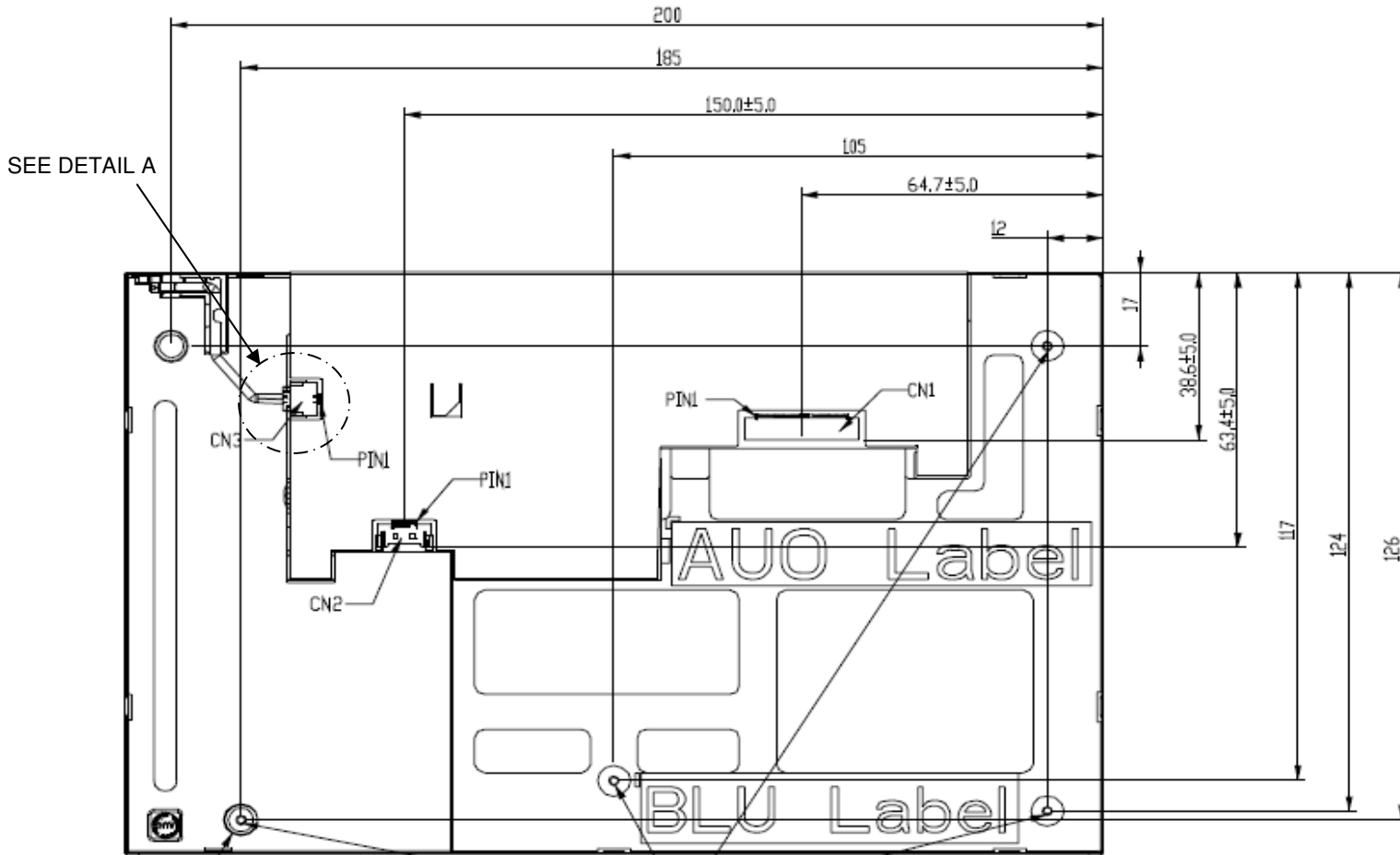

$\phi 7.00(5X)$

$\phi 1.6 \pm 0.1 (4X)$

The hole for nominal size 2mm self-tapping screw attachment; depth 2mm (4 point)

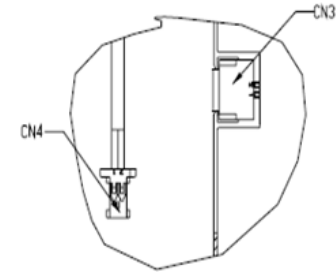

DETAIL A

NOTE:

1.CN1: THE INTERFACE CONNECTOR IS 89H40-001100-G2-R.

CN2: THE LED CONNECTOR IS 3808K-F05N-02R.

2.TOLERANCE IS $\pm 0.5\text{mm}$ IF NOT SPECIFIED.

10. Label and Packaging

10.1 Shipping Label (on the rear side of TFT-LCD display)

TBD

10.2 Carton Package

TBD

11 Safety

11.1 Sharp Edge Requirements

There will be no sharp edges or corners on the display assembly that could cause injury.

11.2 Materials

11.2.1 Toxicity

There will be no carcinogenic materials used anywhere in the display module. If toxic materials are used, they will be reviewed and approved by the responsible AUO toxicologist.

11.2.2 Flammability

All components including electrical components that do not meet the flammability grade UL94-V1 in the module will complete the flammability rating exception approval process.

The pRxINted circuit board will be made from material rated 94-V1 or better. The actual UL flammability rating will be pRxINted on the pRxINted circuit board.

11.3 Capacitors

If any polarized capacitors are used in the display assembly, provisions will be made to keep them from being inserted backwards.

11.4 National Test Lab Requirement

The display module will satisfy all requirements for compliance to:

UL 1950, First Edition

U.S.A. Information Technology Equipment

