

mass integrated

global part distribution • product lifecycle partner
excess inventory management • value-ad service provider



Data sheet provided by Mass Integrated

massintegrated.com • displayalliance.com

Please call +1.978.465.6190
Email: sales@massintegrated.com



ISO 9001: 2008

Mass Integrated complies with all DMCA takedown notices. Please send a formal DMCA Takedown Notice to Mass Integrated Systems, Inc. • 18 Henry Graf Jr. Road, Unit 1 • Newburyport, MA 01950.



Product Specification

G220SW02 V0

AU OPTRONICS CORPORATION

Preliminary Specification

Final Specification

Module	22" WSXGA+ Color TFT-LCD
Model Name	G220SW02 V0

Customer	Date
_____	_____
Checked & Approved by	
_____	_____
Note: This Specification is subject to change without notice.	

Approved by	Date
Debbie Chiu	2010/06/30
Prepared by	
Jimmy Tsai	2010/06/30
General Display Business Division / AU Optronics corporation	

Contents

1. Operating Precautions	4
2. General Description	5
2.1 Display Characteristics	5
2.2 Optical Characteristics	6
3. Functional Block Diagram	10
4. Absolute Maximum Ratings	11
4.1 Absolute Ratings of TFT LCD Module	11
4.2 Absolute Ratings of Environment	11
5. Electrical Characteristics	12
5.1 TFT LCD Module	12
5.2 Backlight Unit.....	14
6. Signal Characteristic	17
6.1 Pixel Format Image	17
6.2 Signal Description.....	18
6.3 The Input Data Format	19
6.4 Interface Timing.....	20
6.5 Power ON/OFF Sequence.....	21
6.6 3D Activity.....	22
7. Connector & Pin Assignment	23
7.1 TFT LCD Module: LVDS Connector	23
7.2 Backlight Unit: LED Connector	24
8. Reliability Test	25
9. Mechanical Characteristics	26
10. Label and Packaging	28
10.1 Shipping Label (on the rear side of TFT-LCD display).....	28
10.2 Carton Package.....	28
11. Safety	29
11.1 Sharp Edge Requirements.....	29
11.2 Materials	29
11.3 Capacitors.....	29
11.4 National Test Lab Requirement.....	29

1. Operating Precautions

- 1) Display area (Polarizer) of TFT-LCD Module is easily to be damaged, please be cautious and not to scratch it.
- 2) Be sure to power off your machine before connecting or disconnecting your signal cable to TFT-LCD Module.
- 3) Wipe off water drop on display area immediately. Long contact with water may cause discoloration or spots.
- 4) When the panel surface is soiled, wipe it with absorbent cotton or soft cloth.
- 5) Display area (Glass) of TFT-LCD Module may be broken or cracked if bump Module against hard object.
- 6) To avoid ESD (Electro Static Discharge) damage, be sure to ground yourself before handling TFT-LCD Module.
- 7) Do not open nor modify the TFT-LCD module assembly.
- 8) Do not press the reflector sheet at the back of the module to any direction.
- 9) In case if TFT-LCD module has to be put back into the packing container slot after it was taken out from the container, do not press the center of the LED Reflector edge. Instead, press at the far ends of the LED Reflector edge softly. Otherwise the TFT-LCD Module may be damaged.
- 10) When inserting or removing of your signal cable to TFT-LCD Module, be sure not to apply abnormal force (rotate, tilt...etc.) to the Connector of the TFT-LCD Module.
- 11) TFT-LCD Module is not allowed to be twisted & bent even force is added on module in a very short time. Please design your display product well to avoid external force applying to module by end-user directly.
- 12) Small amount of materials without flammability grade are used in the TFT-LCD module. The TFT-LCD module should be supplied by power complied with requirements of Limited Power Source (IEC60950 or UL1950), or be applied exemption.
- 13) Severe temperature condition may result in different luminance, response time.
- 14) Continuous operating TFT-LCD Module under high temperature environment may accelerate LED light bar exhaustion and reduce luminance dramatically.
- 15) The data on this specification sheet is applicable when TFT-LCD module is placed in landscape position.
- 16) Continuous displaying fixed pattern may induce image sticking. It's recommended to use screen saver or moving content periodically if fixed pattern is displayed on the screen.

2. General Description

This specification applies to the 22 inch-wide Color TFT-LCD Module G220SW02 V0.

The display supports the WSXGA+ (1680(H) x 1050(V)) screen format and 16.7M colors. All input signals are LVDS interface compatible. LED driver board of backlight is included.

G220SW02 V0 is designed for industrial display applications.

2.1 Display Characteristics

The following items are G220SW02 V0 characteristics summary at 25 °C (Room Temperature).

Items	Unit	Specifications
Screen Diagonal	[inch]	22
Active Area	[mm]	473.76 (H) x 296.1 (V)
Pixels H x V		1680x3(RGB) x 1050
Pixel Pitch	[mm]	0.282x 0.282
Pixel Arrangement		R.G.B. Vertical Stripe
Display Mode		TN Mode, Normally White
Nominal Input Voltage VDD	[Volt]	+5.0 V
Typical Power Consumption	[Watt]	TBD
Weight	[Grams]	3500(Typ)
Physical Size	[mm]	493.7(W) x 320.1(H) x 22.5(D) (Typ)
Electrical Interface		Dual Channel LVDS
Surface Treatment		Hard-coating (3H), Glare type
Support Color		16.7M colors (6-bits + HiFRC)
Temperature Range		
Operating	[°C]	0 to +50
Storage (Non-Operating)	[°C]	-20 to +60
RoHS Compliance		RoHS Compliance

2.2 Optical Characteristics

The optical characteristics are measured under stable conditions at 25°C (Room Temperature):

Item	Unit	Conditions	Min.	Typ.	Max.	Note
White Luminance	[cd/m ²]	2D mode	240	300	-	1
		3D mode	100	120	-	1
Uniformity	%	9 Points	75	80	-	1, 2, 3
Contrast Ratio			800	1000	-	4
Cross talk	%	2D mode	-	-	1.5	5
		3D mode	-	-	5	8
Response Time	[msec]	Rising	-	15	20	6
		Falling	-	10	15	
		Rising + Falling	-	25	35	
Viewing Angle (2D)	[degree] [degree]	Horizontal (Right) CR = 10 (Left)	80 80	85 85	- -	7
	[degree] [degree]	Vertical (Upper) CR = 10 (Lower)	75 75	80 80	- -	
Color / Chromaticity Coordinates (CIE 1931)		Red x	TBD	TBD	TBD	
		Red y	TBD	TBD	TBD	
		Green x	TBD	TBD	TBD	
		Green y	TBD	TBD	TBD	
		Blue x	TBD	TBD	TBD	
		Blue y	TBD	TBD	TBD	
		White x	0.260	0.310	0.360	
		White y	0.280	0.330	0.380	
Color Gamut	%			72	-	

Note 1: Measurement method

Equipment Pattern Generator, Power Supply, Digital Voltmeter, Luminance meter (SR_3 or equivalent)

Aperture 1° with 50cm viewing distance

Test Point Center

Environment < 1 lux

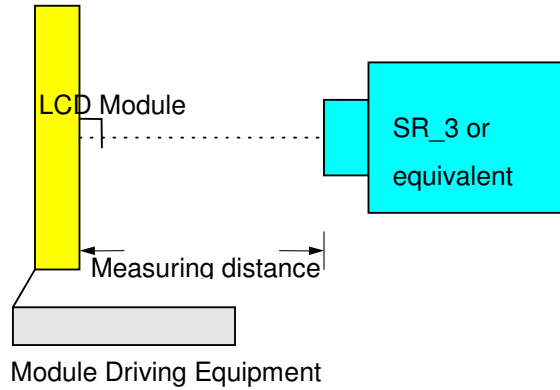

Note 2: Definition of 9 points position (Display active area : 473.76(H) x 296.10(V))

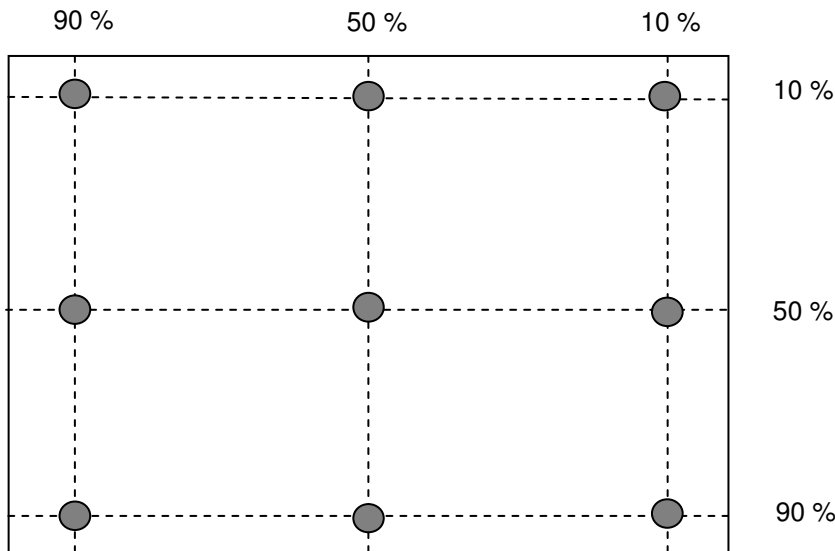

Note 3: The luminance uniformity of 9 points is defined by dividing the minimum luminance values by the maximum test point luminance

$$\delta_{w9} = \frac{\text{Minimum Brightness of nine points}}{\text{Maximum Brightness of nine points}}$$

Note 4 : Definition of contrast ratio (CR):

$$\text{Contrast ratio (CR)} = \frac{\text{Brightness on the "White" state}}{\text{Brightness on the "Black" state}}$$

Note 5 : Definition of cross talk (CT)

$$CT = | YB - YA | / YA \times 100 (\%)$$

Where

YA = Luminance of measured location without gray level 0 pattern (cd/m²)

YB = Luminance of measured location with gray level 0 pattern (cd/m²)

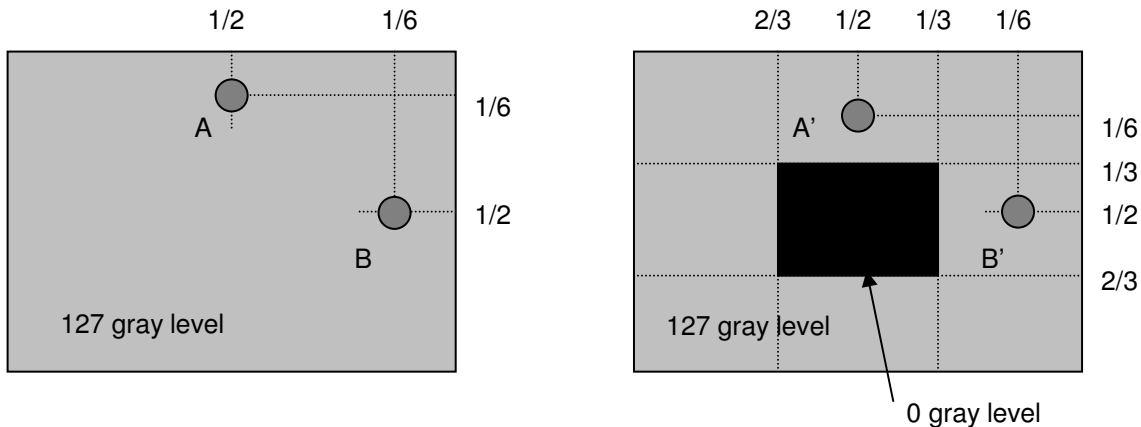

Note 6: Definition of response time:

The output signals of photo detector are measured when the input signals are changed from “White” to “Black” (falling time) and from “Black” to “White” (rising time), respectively. The response time interval is between 10% and 90% of amplitudes. Please refer to the figure as below.

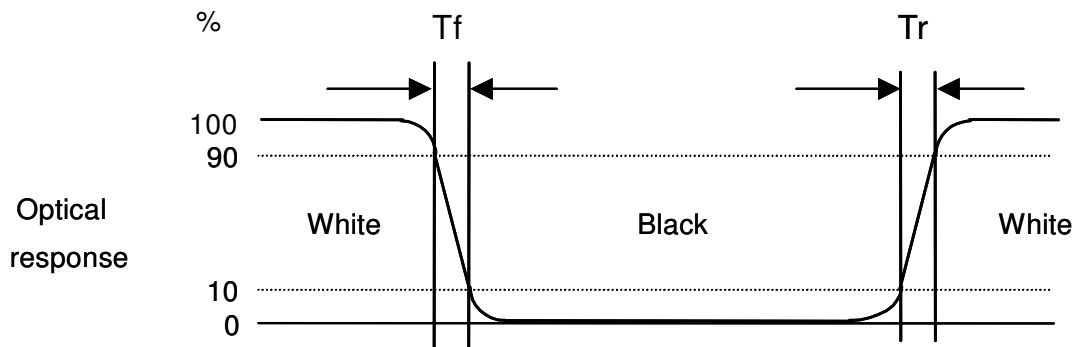

Note 7: Definition of viewing angle

Viewing angle is the measurement of contrast ratio ≥ 10 , at the screen center, over a 180° horizontal and 180° vertical range (off-normal viewing angles). The 180° viewing angle range is broken down as below: 90° (θ) horizontal left and right, and 90° (Φ) vertical high (up) and low (down). The measurement direction is typically perpendicular to the display surface with the screen rotated to its center to develop the desired measurement viewing angle.

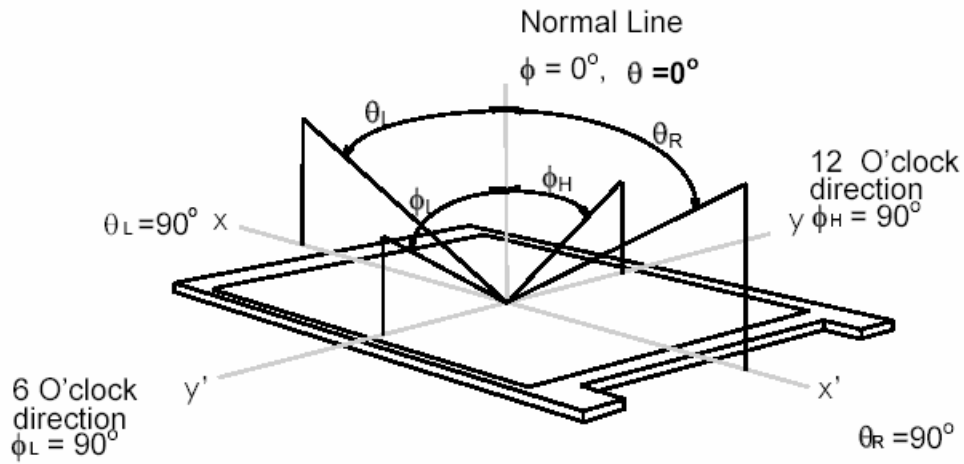

Note 8: Definition of 3D Cross talk

Refer to Note 7, cross talk detecting range is defined $\pm 30^\circ$ (θ) horizontal left and right and 0° (Φ), Under maximum luminance of view 3 at $\pm 10^\circ$ (θ), 3D cross talk is defined as

$$\text{Cross talk (\%)} = \frac{\text{View1} + \text{View5}}{\text{View3}} (\%)$$

3. Functional Block Diagram

The following diagram shows the functional block of the 22 inches wide Color TFT-LCD Module:

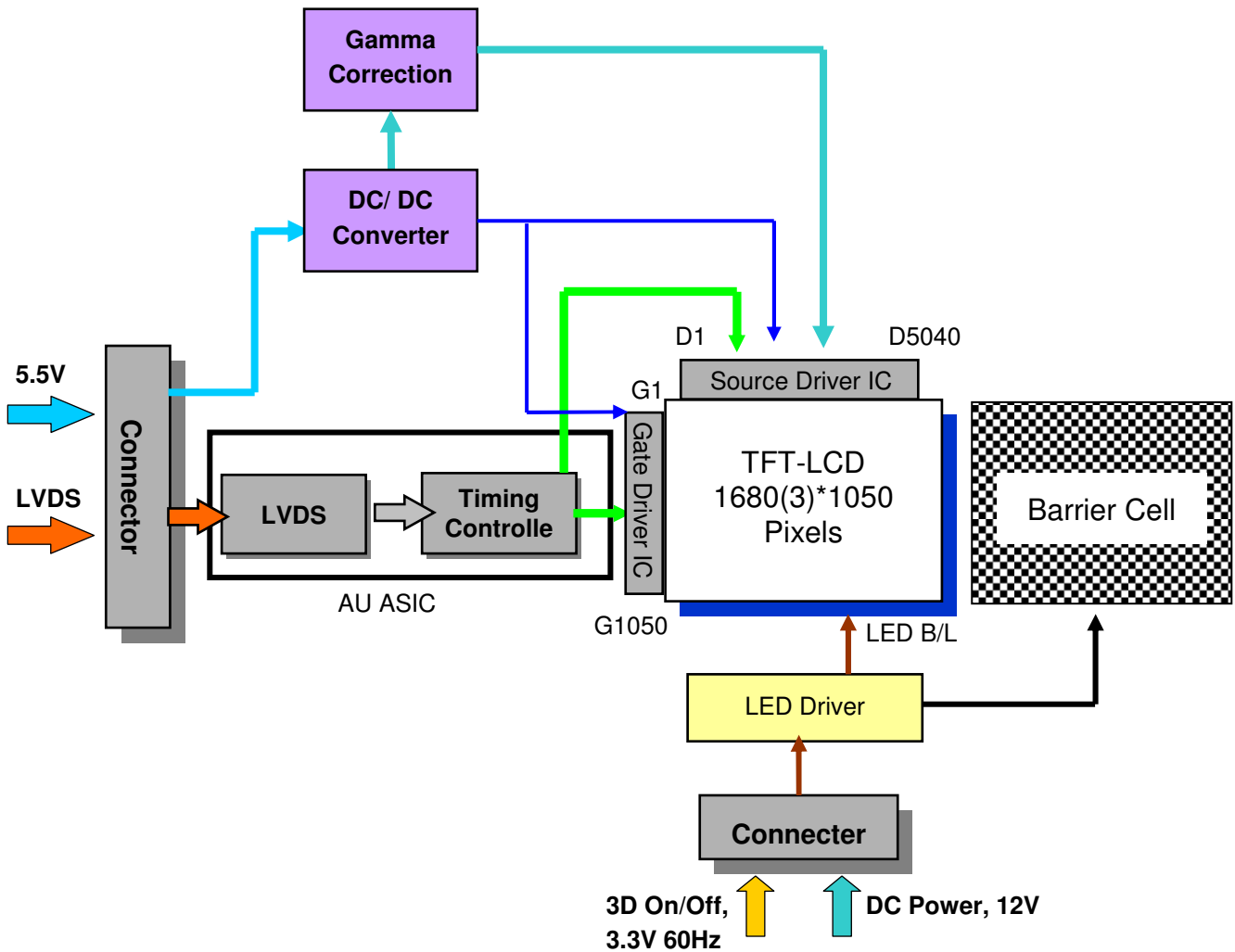

LVDS Connector: **Hirose** (MDF76URW-30S-1H) or equivalent.

LED Connector: **Hirose** (DF14H-20P-1.25H(56)) or equivalent.

4. Absolute Maximum Ratings

4.1 Absolute Ratings of TFT LCD Module

Item	Symbol	Min	Max	Unit
Logic/LCD Drive Voltage	VDD	-0.3	+5.5	[Volt]

4.2 Absolute Ratings of Environment

Item	Symbol	Min	Max	Unit
Operating Temperature	TOP	0	+50	[°C]
Operation Humidity	HOP	5	90	[%RH]
Storage Temperature	TST	-20	+60	[°C]
Storage Humidity	HST	8	90	[%RH]

Note: Maximum Wet-Bulb should be 39°C and no condensation.

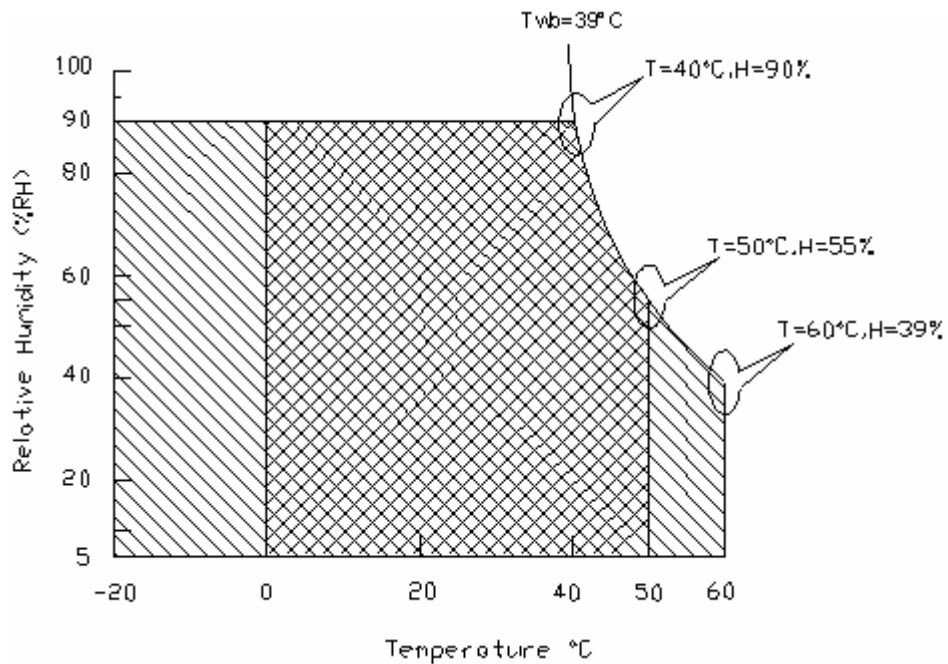

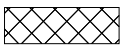
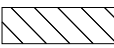
Operating Range  Storage Range  + 

5. Electrical Characteristics

5.1 TFT LCD Module

5.1.1 Power Specification

Symbol	Parameter	Min	Typ	Max	Units	Remark
VDD	Logic/LCD Drive Voltage	4.5	5.0	5.5	[Volt]	± 10%
IDD	VDD Current	-	1000	1400	[mA]	VDD= 5.0V, All Black Pattern At 60Hz
Irush	LCD Inrush Current	-	-	2.5	[A]	Note 1
PDD	VDD Power	-	5	7	[Watt]	VDD= 5.0V, All Black Pattern At 60Hz

Note 1: Measurement condition:

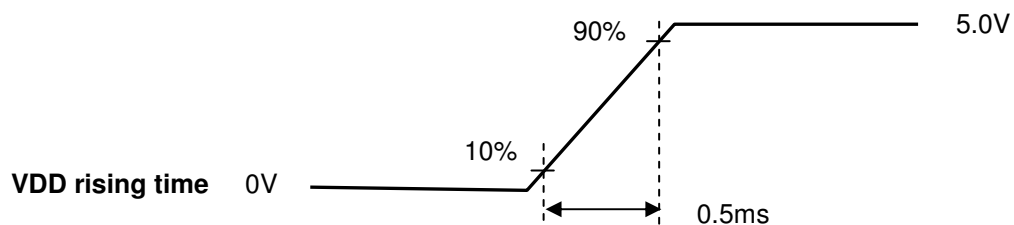
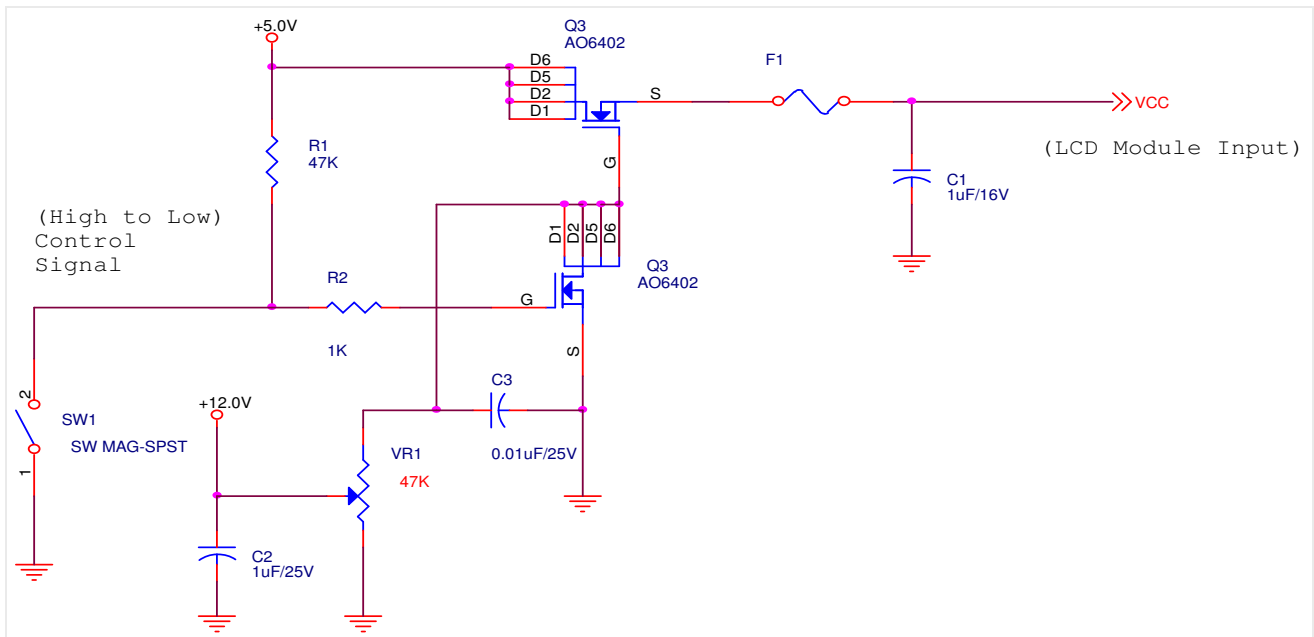

5.1.2 Signal Electrical Characteristics

Input signals shall be low or Hi-Z state when VDD is off.

Symbol	Item	Min.	Typ.	Max.	Unit	Remark
VTH	Differential Input High Threshold	-	-	100	[mV]	VCM=1.2V
VTL	Differential Input Low Threshold	-100	-	-	[mV]	VCM=1.2V
VID	Input Differential Voltage	100	400	600	[mV]	
VICM	Differential Input Common Mode Voltage	0.3	-	1.25	[V]	VTH/VTL=±100mV

Note: LVDS Signal Waveform

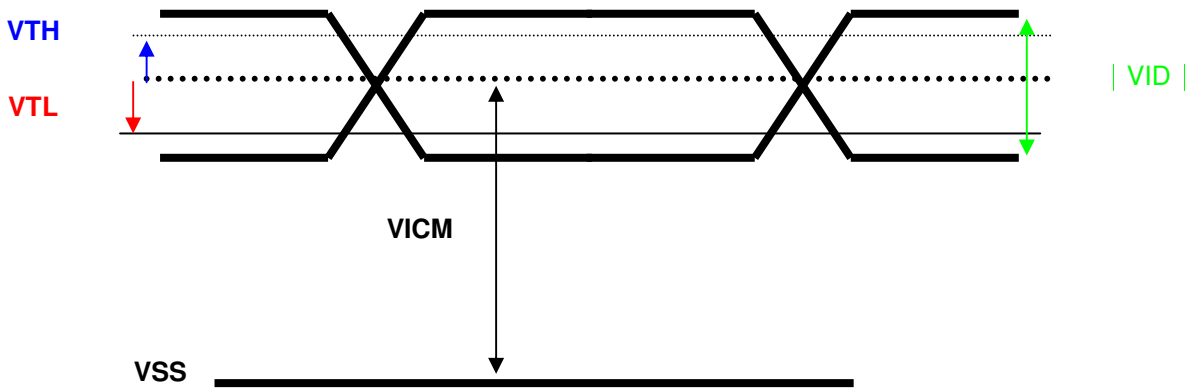

5.2 Backlight Unit

5.2.1 LED Light Bar

Following characteristics are measured under stable condition at 25°C (Room Temperature).

2D mode:

Symbol	Parameter	Min	Typ	Max	Unit	Remark
I_F	LED Forward Current	-	70		mA	Ta = 25°C
V_F	LED Forward Voltage	-	32.4	-	Volt	$I_F = 70\text{mA}$, Ta = 0°C
		-	31.5	36	Volt	$I_F = 70\text{mA}$, Ta = 25°C
		-	29.7	-	Volt	$I_F = 70\text{mA}$, Ta = 50°C
P_{LED}	LED Power	-	2.2	2.5	Watt	One string , $I_F = 70\text{mA}$, Ta = 25°C
Operating Life		50,000			Hrs	$I_F = 70\text{mA}$, Ta = 25°C

3D mode:

Symbol	Parameter	Min	Typ	Max	Unit	Remark
I_F	LED Forward Current	-	120		mA	Ta = 25°C
V_F	LED Forward Voltage	-	32.4	-	Volt	$I_F = 120\text{mA}$, Ta = 0°C
		-	31.5	36	Volt	$I_F = 120\text{mA}$, Ta = 25°C
		-	29.7	-	Volt	$I_F = 120\text{mA}$, Ta = 50°C
P_{LED}	LED Power	-	3.8	4.3	Watt	One string, $I_F = 70\text{mA}$, Ta = 25°C
Operating Life		TBD			Hrs	$I_F = 120\text{mA}$, Ta = 25°C, Ti < TBD °C

Note 1: Ta means ambient temperature of TFT-LCD module.

Note 2: If G220SW02 V0 module is driven by high current or at high ambient temperature & humidity condition. The operating life will be reduced.

Note 3: Operating life means brightness goes down to 50% initial brightness. Typical operating life time is estimated data.

Note 4: LED light bar structure:



Note 5: T_i = Temp. on below position.



5.2.2 LED Driver Board (Embedded)

Following characteristics are measured under stable condition at 25°C (Room Temperature).

2D Mode:

Symbol	Parameter	Min.	Typ.	Max.	Unit	Remark
VCC	Input Voltage	-	12	12.6	[Volt]	$I_F = 70\text{mA}$, $T_a = 25^\circ\text{C}$
I _{VCC}	Input Current	-	1.2	1.5	[A]	100% PWM Duty
P _{VCC}	Power Consumption	-	14.4	18.9	[Watt]	100% PWM Duty
I _{rush LED}	Inrush Current	-	-	1.5	[A]	at rising time=470us
F _{PWM}	Dimming Frequency	100	-	10K	[Hz]	
	Swing Voltage	3	3.3	5.5	[Volt]	
	Dimming duty cycle	10	-	100	%	

3D Mode:

Symbol	Parameter	Min.	Typ.	Max.	Unit	Remark
VCC	Input Voltage	-	12	12.6	[Volt]	$I_F = 120\text{mA}$, $T_a = 25^\circ\text{C}$
I _{VCC}	Input Current	-	2.3	2.6	[A]	100% PWM Duty
P _{VCC}	Power Consumption	-	28	32.76	[Watt]	100% PWM Duty
I _{rush LED}	Inrush Current	-	-	1.5	[A]	at rising time=470us
F _{PWM}	Dimming Frequency	100	-	10K	[Hz]	
	Swing Voltage	3	3.3	5.5	[Volt]	
	Dimming duty cycle	10	-	100	%	

6.2 Signal Description

The module using a pair of LVDS receiver SN75LVDS82(Texas Instruments) or compatible. LVDS is a differential signal technology for LCD interface and high speed data transfer device. Transmitter shall be SN75LVDS83(negative edge sampling) or compatible. The first LVDS port(RxOxxx) transmits odd pixels while the second LVDS port(RxExxx) transmits even pixels.

PIN #	SIGNAL NAME	DESCRIPTION
1	RXinO0-	Negative LVDS differential data input (Odd data)
2	RXinO0+	Positive LVDS differential data input (Odd data)
3	RXinO1-	Negative LVDS differential data input (Odd data)
4	RXinO1+	Positive LVDS differential data input (Odd data)
5	RXinO2-	Negative LVDS differential data input (Odd data, H-Sync, V-Sync, DSPTMG)
6	RXinO2+	Positive LVDS differential data input (Odd data, H-Sync, V-Sync, DSPTMG)
7	GND	Power Ground
8	RxOCLKIN-	Negative LVDS differential clock input (Odd clock)
9	RxOCLKIN+	Positive LVDS differential clock input (Odd clock)
10	RXinO3-	Negative LVDS differential data input (Odd data)
11	RXinO3+	Positive LVDS differential data input (Odd data)
12	RXinE0-	Negative LVDS differential data input (Even data)
13	RXinE0+	Positive LVDS differential data input (Even data)
14	GND	Power Ground
15	RXinE1-	Positive LVDS differential data input (Even data)
16	RXinE1+	Negative LVDS differential data input (Even data)
17	GND	Power Ground
18	RXinE2-	Negative LVDS differential data input (Even data)
19	RXinE2+	Positive LVDS differential data input (Even data)
20	RxECLKIN-	Negative LVDS differential clock input (Even clock)
21	RxECLKIN+	Positive LVDS differential clock input (Even clock)
22	RXinE3-	Negative LVDS differential data input (Even data)
23	RXinE3+	Positive LVDS differential data input (Even data)
24	GND	Power Ground
25	NC	No contact (For AUO test only)
26	NC	No contact (For AUO test only)
27	NC	No contact (For AUO test only)
28	VDD	+5.0V Power Supply
29	VDD	+5.0V Power Supply
30	VDD	+5.0V Power Supply

6.3 The Input Data Format

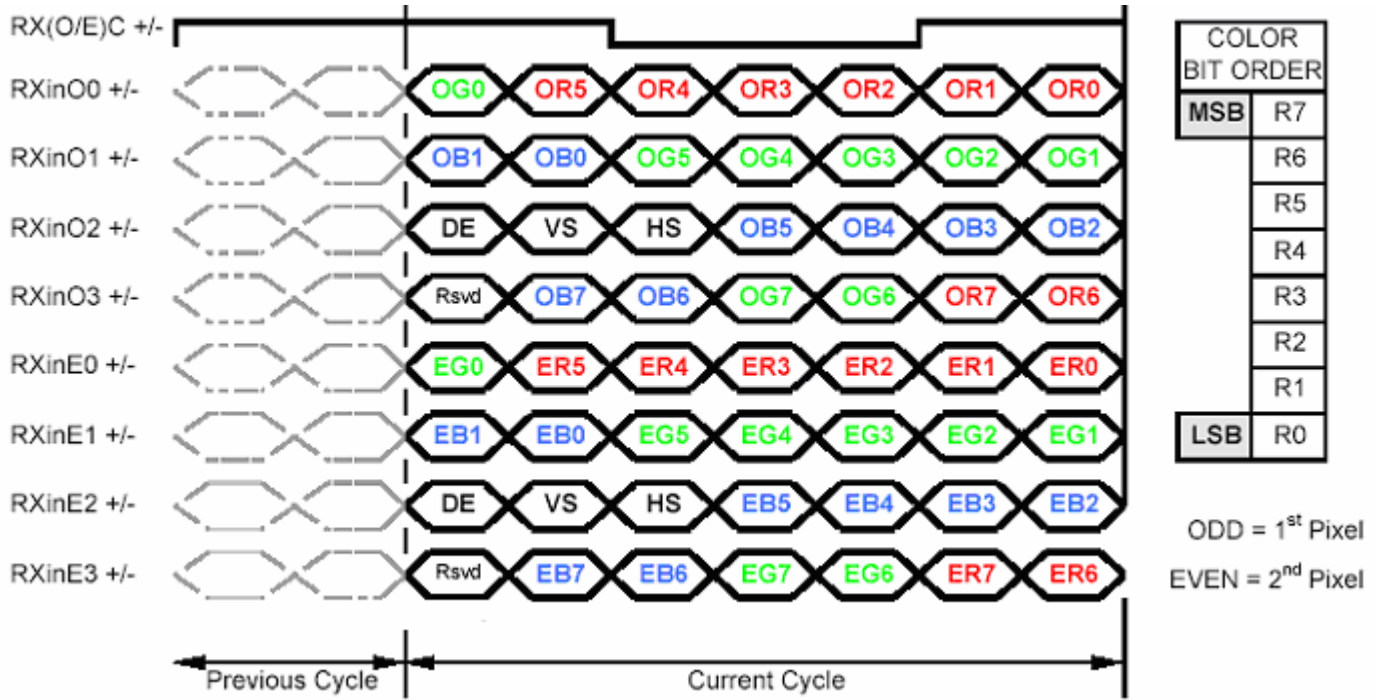

Note1: 8-bits signal input.
 Note2: L:NS alike H:Thine alike

6.4 Interface Timing

6.4.1 Timing Characteristics

Signal	Item	Symbol	Min	Typ	Max	Unit
Clock	Frequency	$1/T_{Clock}$	60	72.1	85	MHz
Frame Rate	Frequency	$1/T_v$	50	60	75	Hz
Vertical Section	Period	T_v	1058	1066	2048	T_line
	Active	T_{vD}	1050	1050	1050	
	Blanking	T_{vB}	8	16	998	
Horizontal Section	Period	T_H	880	1128	2048	T_clock
	Active	T_{HD}	840	840	840	
	Blanking	T_{HB}	40	288	1208	

Note: DE mode only.

6.4.2 Input Timing Diagram

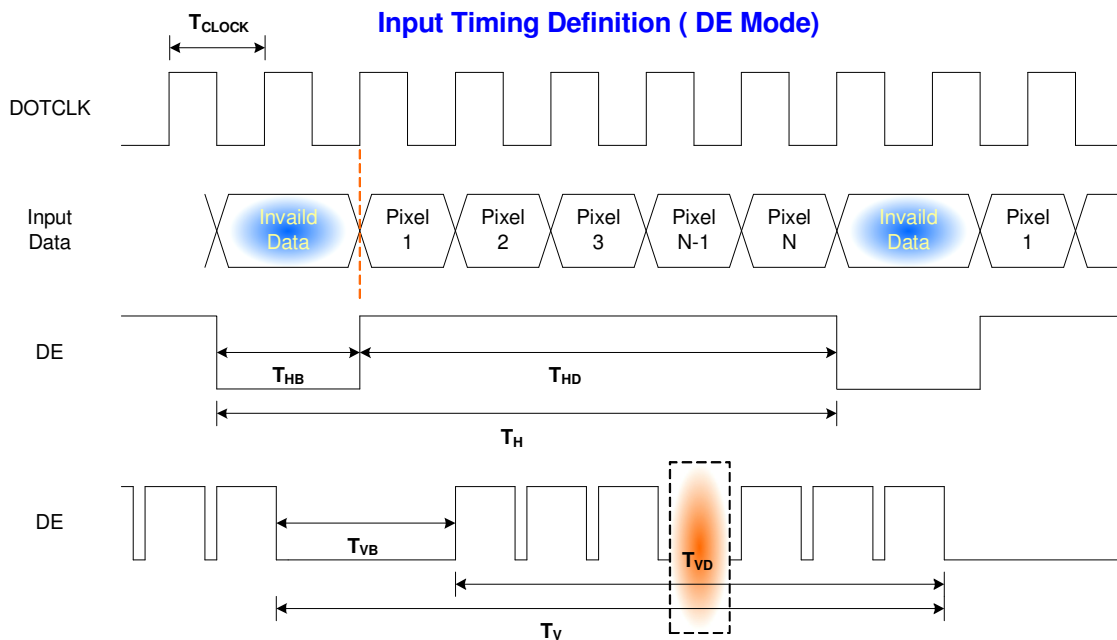

6.5 Power ON/OFF Sequence

VDD power and lamp on/off sequence is as below. Interface signals are also shown in the chart. Signals from any system shall be Hi-Z state or low level when VDD is off.

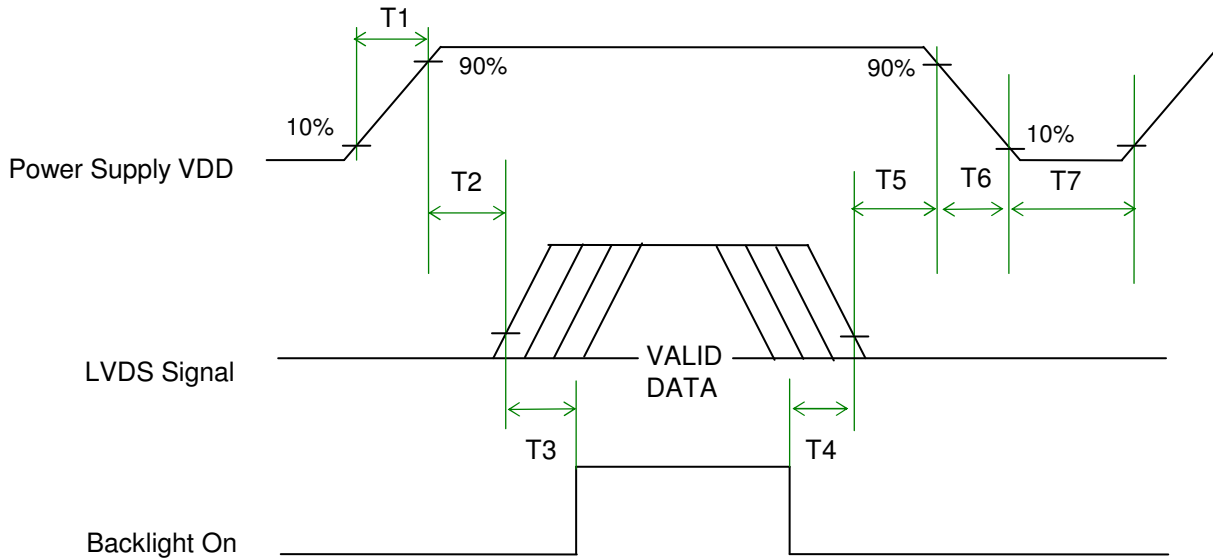

Power ON/OFF sequence timing

Parameter	Value			Units
	Min.	Typ.	Max.	
T1	0.5	-	10	[ms]
T2	0	40	50	[ms]
T3	200	-	-	[ms]
T4	200	-	-	[ms]
T5	0.5	16	50	[ms]
T6	-	-	100	[ms]
T7	1000	-	-	[ms]

The above on/off sequence should be applied to avoid abnormal function in the display. Please make sure to turn off the power when you plug the cable into the input connector or pull the cable out of the connector.

6.6 3D Activity

6.6.1 3D Data Arrangement

3D data arrangement shown as below.

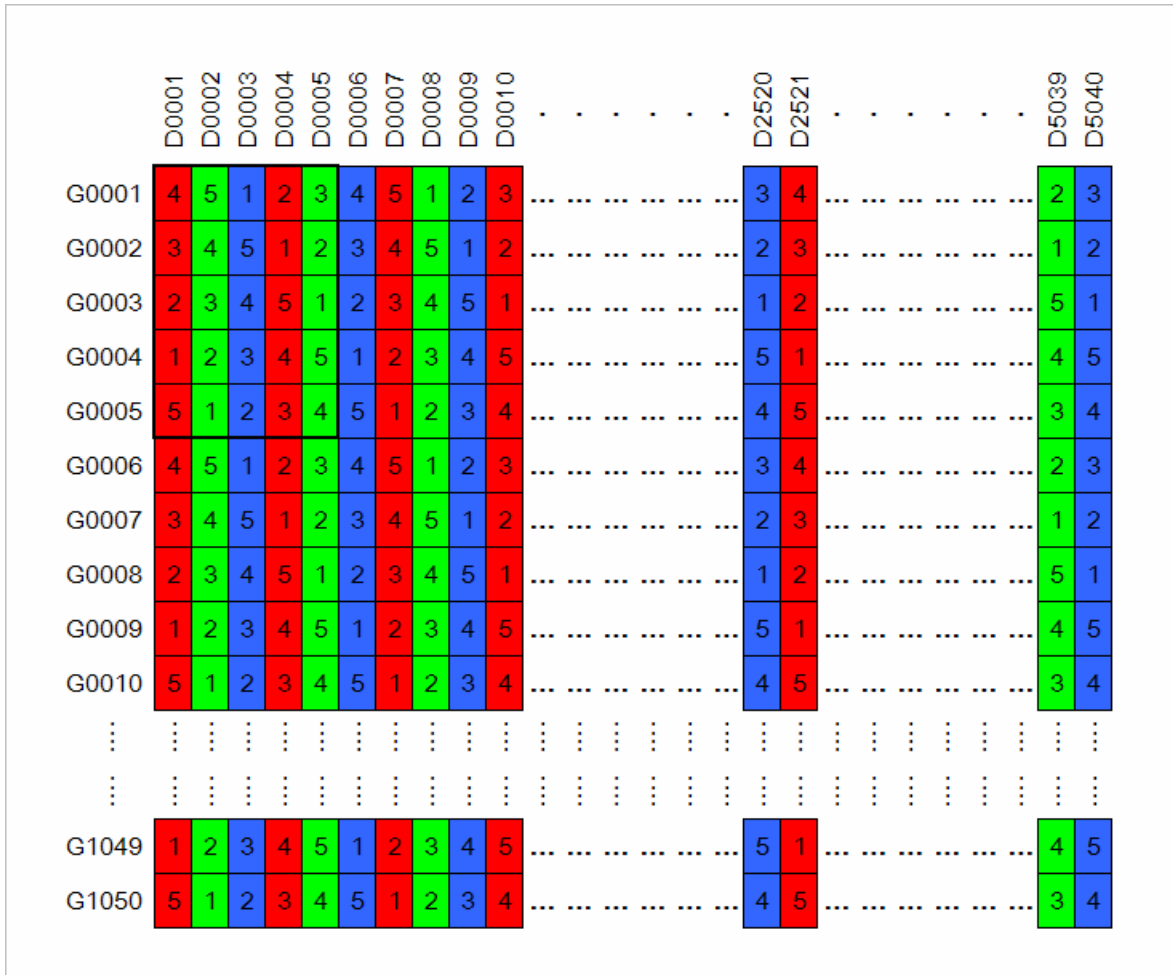

2D resolution : 1680 x 3 x 1050, for 5 view content, view number = 1, 2, 3, 4, 5,

6.6.2 How to Turn On 3D Mode

2D Mode: pin 19th: Ground

3D Mode: pin 19th: input 3.3V, DC, pull high

LED Connector Pin Defines

PIN #	SIGNAL NAME	DESCRIPTION
19	3D_EN	3D enable, 3.3V

7. Connector & Pin Assignment

Physical interface is described as for the connector on module. These connectors are capable of accommodating the following signals and will be following components.

7.1 TFT LCD Module: LVDS Connector

Connector Name / Designation	Interface Connector / Interface card
Manufacturer	LVDS: HIROSE/ JAE or compatible
Type Part Number	LVDS :MDF76URW-30S-1H/ FI-XB30SSRL-HF16
Mating Housing Part Number	FI-X30S-H (Unlocked Type) or equivalent

Pin#	Signal Name	Pin#	Signal Name
1	RXinO0-	16	RXinE1+
2	RXinO0+	17	GND
3	RXinO1-	18	RXinE2-
4	RXinO1+	19	RXinE2+
5	RXinO2-	20	RxECLKIN-
6	RXinO2+	21	RxECLKIN+
7	GND	22	RXinE3-
8	RxOCLKIN-	23	RXinE3+
9	RxOCLKIN+	24	GND
10	RXinO3-	25	NC
11	RXinO3+	26	NC
12	RXinE0-	27	NC
13	RXinE0+	28	VDD
14	GND	29	VDD
15	RXinE1-	30	VDD

7.2 Backlight Unit: LED Connector

Connector Name / Designation	Lamp Connector
Manufacturer	Hirose / Entery or compatible
Connector Model Number	DF14H-20P-1.25H(56) / 3804-E20E05
Mating Model Number	DF14-20S-1.25C or compatible

PIN #	SIGNAL NAME	DESCRIPTION
1	V12_1	Light bar 1 input voltage, 12V
2	V12_1	Light bar 1 input voltage, 12V
3	V12_1	Light bar 1 input voltage, 12V
4	V12_1	Light bar 1 input voltage, 12V
5	V12_2	Light bar 2 input voltage, 12V
6	V12_2	Light bar 2 input voltage, 12V
7	V12_2	Light bar 2 input voltage, 12V
8	V12_2	Light bar 2 input voltage, 12V
9	GND	Ground
10	GND	Ground
11	GND	Ground
12	GND	Ground
13	GND	Ground
14	GND	Ground
15	BL_DIM_A	Back light dimming, 0~5V
16	BL_EN	Back light enable, 5V
17	GND	Ground
18	BL_DIM_P	Back light dimming, 100-10kHz
19	3D_EN	3D enable, 3.3V
20	GND	Ground

8. Reliability Test

Environment test conditions are listed as following table.

Items	Required Condition	Note
Temperature Humidity Bias (THB)	Ta= 50℃, 80%RH, 300hours	3
High Temperature Operation (HTO)	Ta= 50℃, 300hours	3
Low Temperature Operation (LTO)	Ta= 0℃, 300hours	3
High Temperature Storage (HTS)	Ta= 60℃, 300hours	
Low Temperature Storage (LTS)	Ta= -20℃, 300hours	
Vibration Test (Non-operation)	Acceleration: 1.5 G Wave: Random Frequency: 10 - 200 - 10 Hz Sweep: 30 Minutes each Axis (X, Y, Z)	
Shock Test (Non-operation)	Acceleration: 50 G Wave: Half-sine Active Time: 20 ms Direction: ±X, ±Y, ±Z (one time for each Axis)	
Drop Test	Height: 60 cm, package test	
Thermal Shock Test (TST)	-20℃/30min, 60℃/30min, 100 cycles	1, 3
On/Off Test	On/10sec, Off/10sec, 30,000 cycles	3
ESD (ElectroStatic Discharge)	Contact Discharge: ± 8KV, 150pF(330Ω) 1sec, 8 points, 25 times/ point.	2
	Air Discharge: ± 15KV, 150pF(330Ω) 1sec 8 points, 25 times/ point.	
Altitude Test	Operation:10,000 ft Non-Operation:30,000 ft	3

Note 1: The TFT-LCD module will not sustain damage after being subjected to 100 cycles of rapid temperature change. A cycle of rapid temperature change consists of varying the temperature from -20℃ to 60℃, and back again. Power is not applied during the test. After temperature cycling, the unit is placed in normal room ambient for at least 4 hours before power on.

Note 2: According to EN61000-4-2, ESD class B: Some performance degradation allowed. No data lost. Self-recoverable. No hardware failures.

Note 3: The test is under this condition, LED current is 70 mA.

9. Mechanical Characteristics

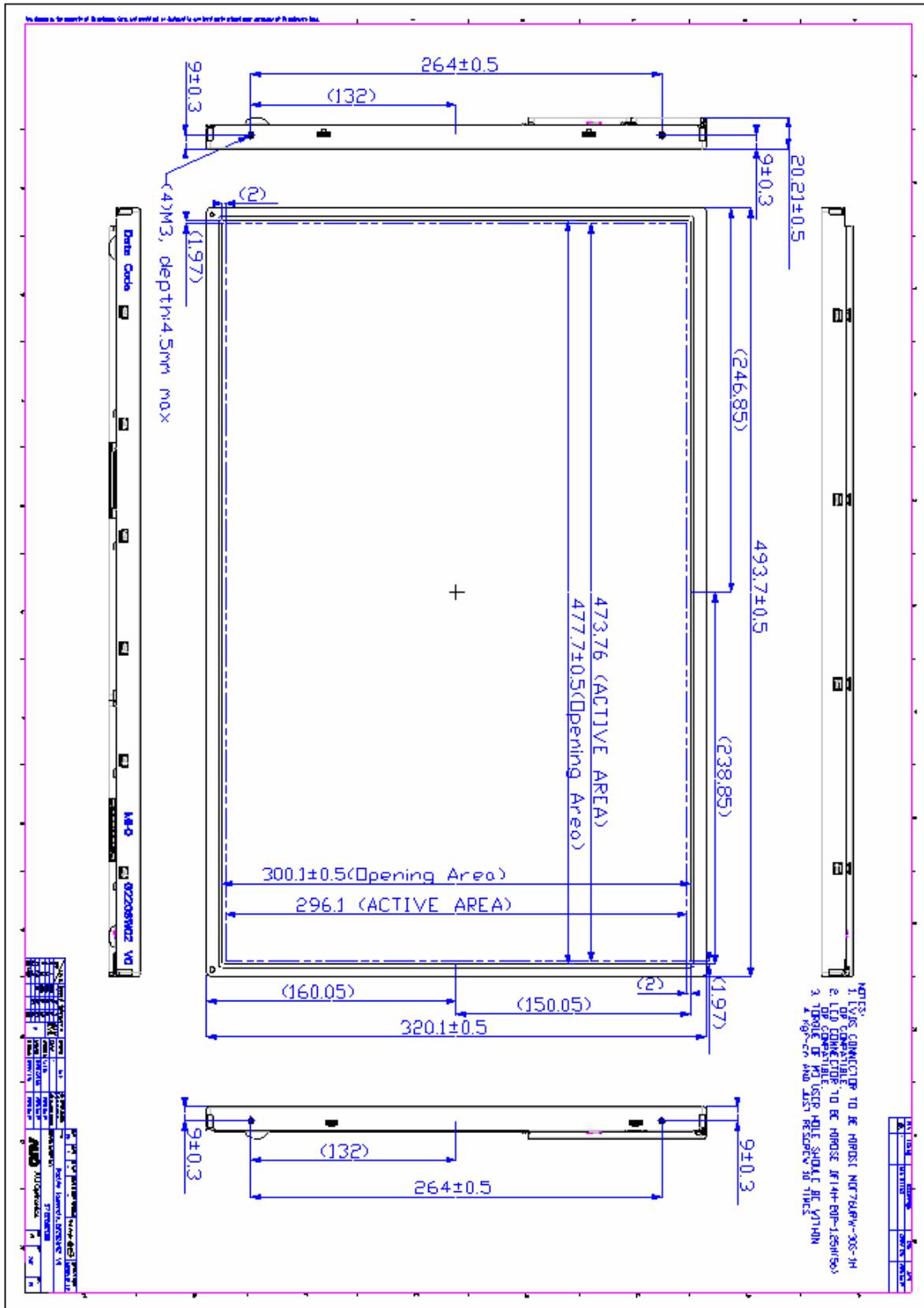

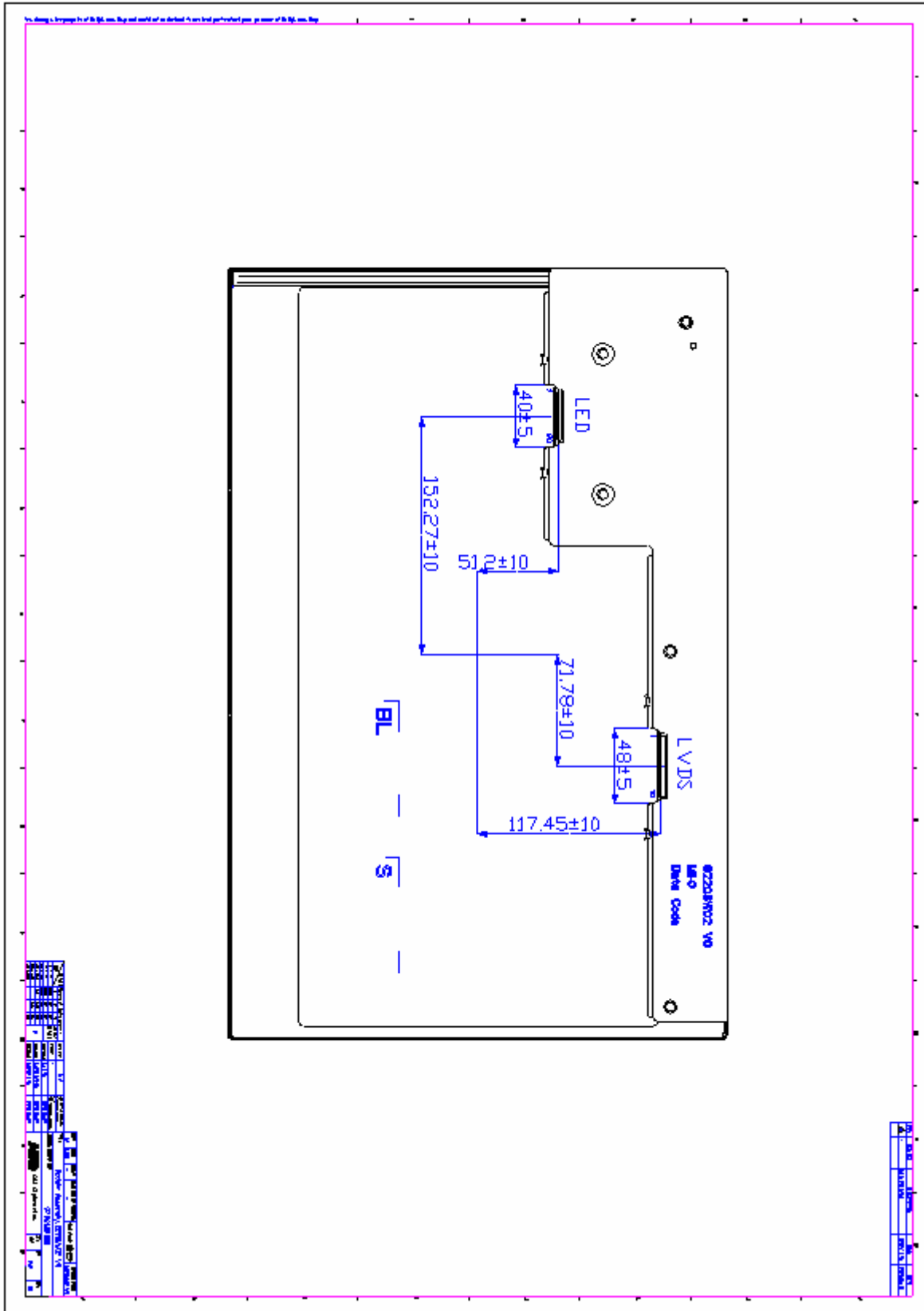

10. Label and Packaging

10.1 Shipping Label (on the rear side of TFT-LCD display)

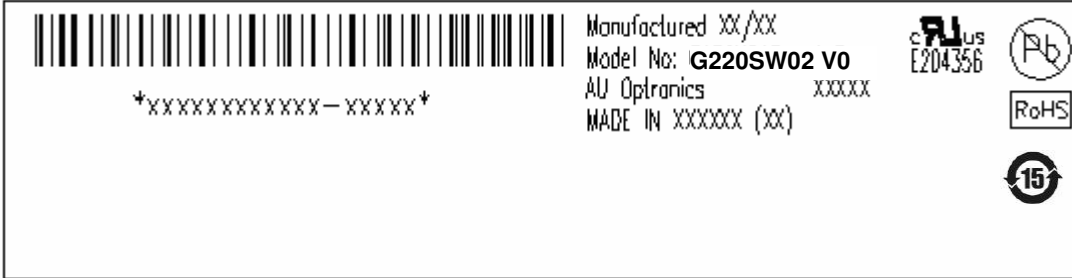

10.2 Carton Package

- Max capacity: 22 TFT-LCD module per carton (8pcs * 1 layers)
- Max weight: 26 kg per carton
- Outside dimension of carton: 562(L)mm* 275(W)mm* 426(H)mm



11. Safety

11.1 Sharp Edge Requirements

There will be no sharp edges or comers on the display assembly that could cause injury.

11.2 Materials

11.2.1 Toxicity

There will be no carcinogenic materials used anywhere in the display module. If toxic materials are used, they will be reviewed and approved by the responsible AUO toxicologist.

11.2.2 Flammability

All components including electrical components that do not meet the flammability grade UL94-V1 in the module will complete the flammability rating exception approval process.

The printed circuit board will be made from material rated 94-V1 or better. The actual UL flammability rating will be printed on the printed circuit board.

11.3 Capacitors

If any polarized capacitors are used in the display assembly, provisions will be made to keep them from being inserted backwards.

11.4 National Test Lab Requirement

The display module will satisfy all requirements for compliance to:

UL 1950, First Edition

U.S.A. Information Technology Equipment