

mass integrated

global part distribution • product lifecycle partner
excess inventory management • value-ad service provider



Data sheet provided by Mass Integrated

massintegrated.com • displayalliance.com

Please call +1.978.465.6190
Email: sales@massintegrated.com



ISO 9001: 2008

Mass Integrated complies with all DMCA takedown notices. Please send a formal DMCA Takedown Notice to Mass Integrated Systems, Inc. • 18 Henry Graf Jr. Road, Unit 1 • Newburyport, MA 01950.



Document Title	HSD100PXN1-A00-C10 Tentative Specification	Page No.	1/27
Document No.		Revision	1.1

TO :

Date : Dec., 9, 2010

HannStar Product Specification **(Tentative)**

Model: HSD100PXN1-A00-C10

- Note: (1) The information contained herein is tentative and may be changed without prior notices
(2) Please contact HannStar Display Corp. before designing your product based on this module specification.
(3) The information contained herein is presented merely to indicate the characteristics and performance of our products. No responsibility is assumed by HannStar for any intellectual property claims or other problems that may result from application based on the module described herein.



Document Title	HSD100PXN1-A00-C10 Tentative Specification	Page No.	2/27
Document No.		Revision	1.1

Record of Revisions

Rev.	Date	Sub-Model	Description of change
1.1	Dec., 09, 2010	A00-C10	Tentative Specification was first released.



Document Title	HSD100PXN1-A00-C10 Tentative Specification	Page No.	3/27
Document No.		Revision	1.1

Contents

1.0	General description	p.4
2.0	Absolute maximum ratings.....	p.5
3.0	Optical characteristics.....	p.6
4.0	Block diagram	p.10
5.0	Interface pin connection	p.12
6.0	Electrical characteristics	p.14
7.0	Reliability test items	p.21
8.0	Outline dimension	p.22
9.0	Lot mark	p.24
10.0	Package specification	p.25
11.0	General precaution	p.26

Document Title	HSD100PXN1-A00-C10 Tentative Specification	Page No.	4/27
Document No.		Revision	1.1

1.0 GENERAL DESCRIPTION

1.1 Introduction

HannStar Display model HSD100PXN1-A00-C10 is a color active matrix thin film transistor (TFT) liquid crystal display (LCD) that uses amorphous silicon TFT as a switching device. This model is composed of a TFT LCD panel, a driving circuit, back light system, projected capacitive touch sensor, and cover lens. This TFT LCD with projected capacitive touch sensor has a 10(4:3) inch diagonally measured active display area with XGA (1024 horizontal by 768 vertical pixel) resolution.

1.2 Features

- 10 (4:3 diagonal) inch configuration
- Multi-Finger touch function (2D)
- 262K color by 6 bit R.G.B signal input

1.3 Applications

- NB
- Tablet PC
- Display terminal for AV application

1.4 General information

Item	Specification	Unit
Outline Dimension	236.7(Typ) x 183.6(Typ) w/ Cover Lens	mm
Display area	202.75 (H) x 152.06 (V)	mm
Number of Pixel	1024 RGB (H) x 768(V)	pixels
Pixel pitch	0.198(H) x 0.198(V)	mm
Pixel arrangement	RGB Vertical stripe	
Display mode	Normally white	
NTSC	50	%
Surface treatment	Antiglare, Hard-Coating (3H)	
Weight	(283) (Max.)	g
Back-light	White LED	
Power Consumption	Logic System	0.72 (Max.)
	B/L	1.73 (Max.)

Document Title	HSD100PXN1-A00-C10 Tentative Specification	Page No.	5/27
Document No.		Revision	1.1

1.5 Mechanical Information

Item		Min.	Typ.	Max.	Unit
Module Size	Horizontal (H)	236.20	236.70	237.20	mm
	Vertical (V)	183.10	183.60	184.10	mm
	Depth (D)	—	—	7.1	mm
Weight		—	(268)	(283)	g

2.0 ABSOLUTE MAXIMUM RATINGS

2.1 Electrical Absolute Rating

2.1.1 TFT LCD Module

Item	Symbol	Min.	Max.	Unit	Note
Logic Supply voltage	V_{DD}	-0.3	6.0	V	

2.1.2 Environment Absolute Rating

Item	Symbol	Min.	Max.	Unit	Note
Operating Temperature	T_{opa}	0	50	°C	
Storage Temperature	T_{stg}	-20	60	°C	

Document Title	HSD100PXN1-A00-C10 Tentative Specification	Page No.	6/27
Document No.		Revision	1.1

3.0 OPTICAL CHARACTERISTICS

3.1 Optical specification

Item		Symbol	Condition	Min.	Typ.	Max.	Unit	Note	
Contrast		CR	$\Theta=0$ Normal viewing angle	480	600	—		(1)(2)(4)	
Response time	Rising	Tr		—	3	6	msec	(1)(3)	
	Falling	Tf		—	9	18			
White luminance (5 point)		Y_L			140	180	—	cd/m ²	(1)(4)(5) ($I_L=140mA$)
Color chromaticity (CIE1931)	Red	R_x			0.557	0.607	0.657		
		R_y			0.303	0.353	0.403		
	Green	G_x			0.261	0.311	0.361		
		G_y			0.491	0.541	0.591		
	Blue	B_x			0.098	0.148	0.198		
		B_y			0.068	0.118	0.168		
	White	W_x		0.263	0.313	0.363			
		W_y		0.279	0.329	0.379			
Viewing angle	Hor.	Θ_L	CR>10	65	75	—		(1)(4)	
		Θ_R		65	75	—			
	Ver.	Θ_U		50	60	—			
		Θ_D		60	70	—			
Brightness uniformity		B_{UNI}	$\Theta=0$ (5point)	—	—	1.25		(5)	
Brightness Uniformity		B_{UNI}	$\Theta=0$ (13 points)	—	—	1.5		(6)	

3.2 Measuring Condition

- Measuring surrounding : dark room
- LED Current I_L : 140mA
- Ambient temperature : 25±2°C
- 15min. warm-up time.

Document Title	HSD100PXN1-A00-C10 Tentative Specification	Page No.	7/27
Document No.		Revision	1.1

3.3 Measuring Equipment

- FPM520 of Westar Display technologies, INC., which utilized SR-3 for Chromaticity and BM-5A for other optical characteristics.
- Measuring spot size : 20 ~ 21 mm

Note (1) Definition of Viewing Angle:

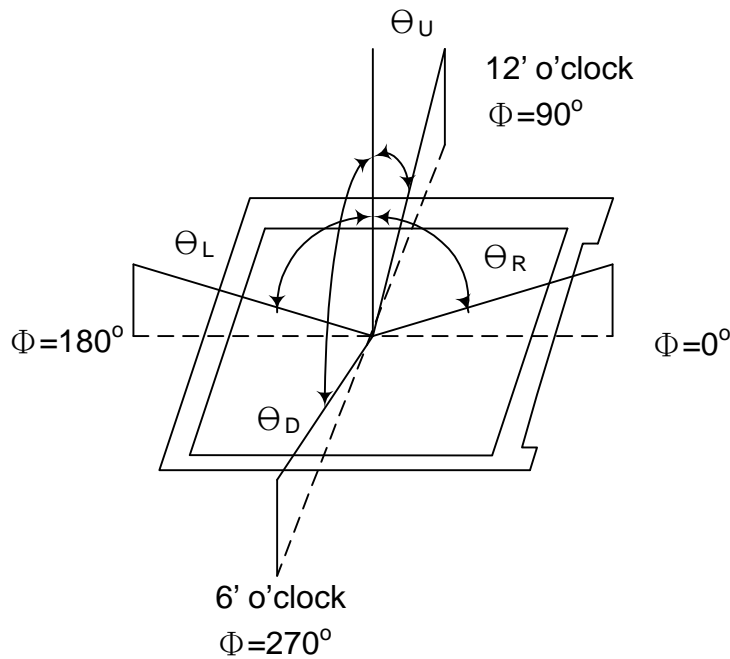

Note (2) Definition of Contrast Ratio (CR) :
measured at the center point of panel

$$CR = \frac{\text{Luminance with all pixels white}}{\text{Luminance with all pixels black}}$$

Document Title	HSD100PXN1-A00-C10 Tentative Specification	Page No.	8/27
Document No.		Revision	1.1

Note (3) Definition of Response Time : Sum of T_R and T_F

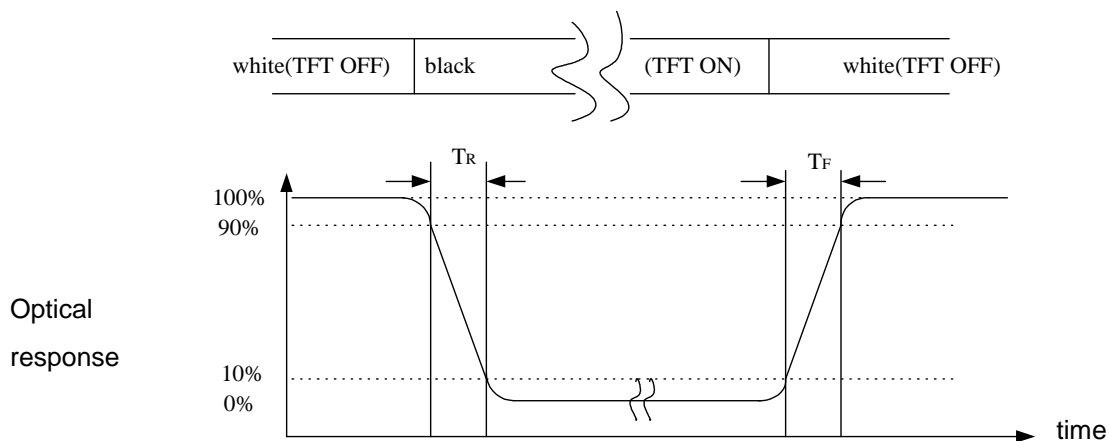

Note (4) Definition of optical measurement setup

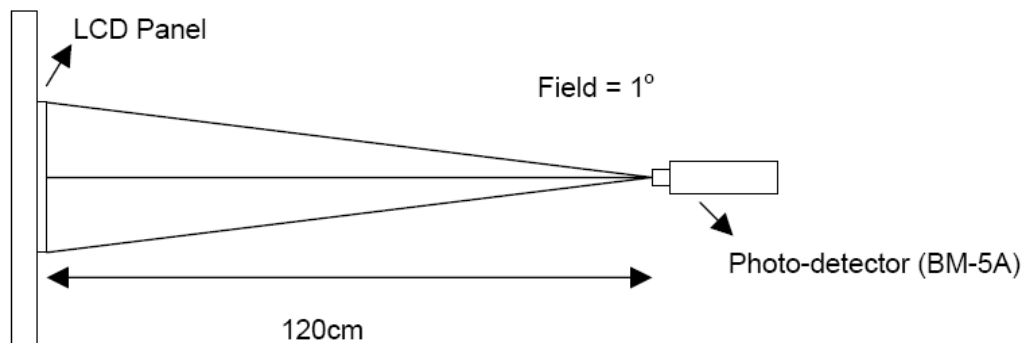

Document Title	HSD100PXN1-A00-C10 Tentative Specification	Page No.	9/27
Document No.		Revision	1.1

Note (5) Definition of Average Luminance Uniformity of White (5 Point)

$$\text{Average Luminance Uniformity} = \frac{Y_1+Y_2+Y_3+Y_4+Y_5}{5}$$

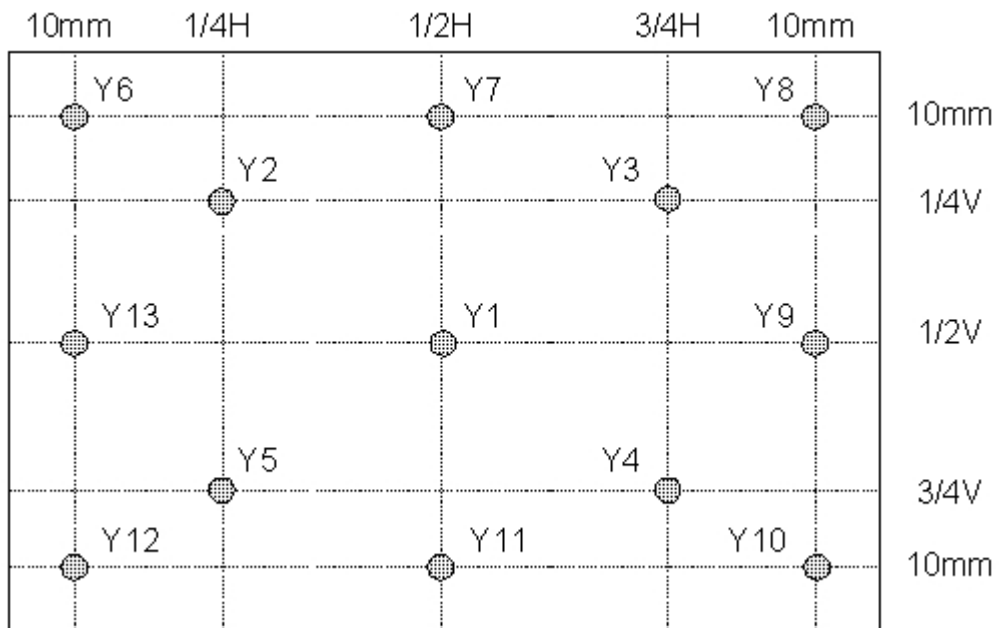

Note (6) Definition of brightness uniformity

$$\text{Luminance uniformity(5 points)} = \frac{(\text{Max Luminance of 5 points})}{(\text{Min Luminance of 5 points})}$$

$$\text{Luminance uniformity(13points)} = \frac{(\text{Max Luminance of 13 points})}{(\text{Min Luminance of 13 points})}$$

Document Title	HSD100PXN1-A00-C10 Tentative Specification	Page No.	10/27
Document No.		Revision	1.1

4.0 BLOCK DIAGRAM

4.1 TFT LCD Module:

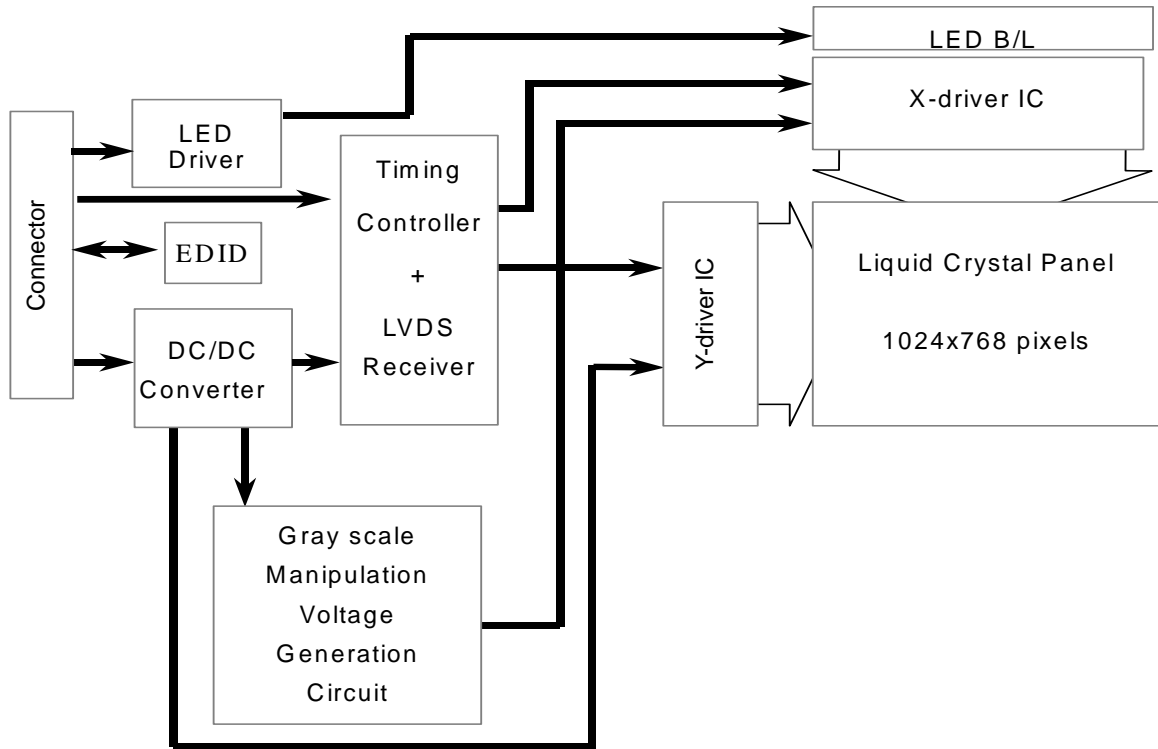

4.2 Pixel Format

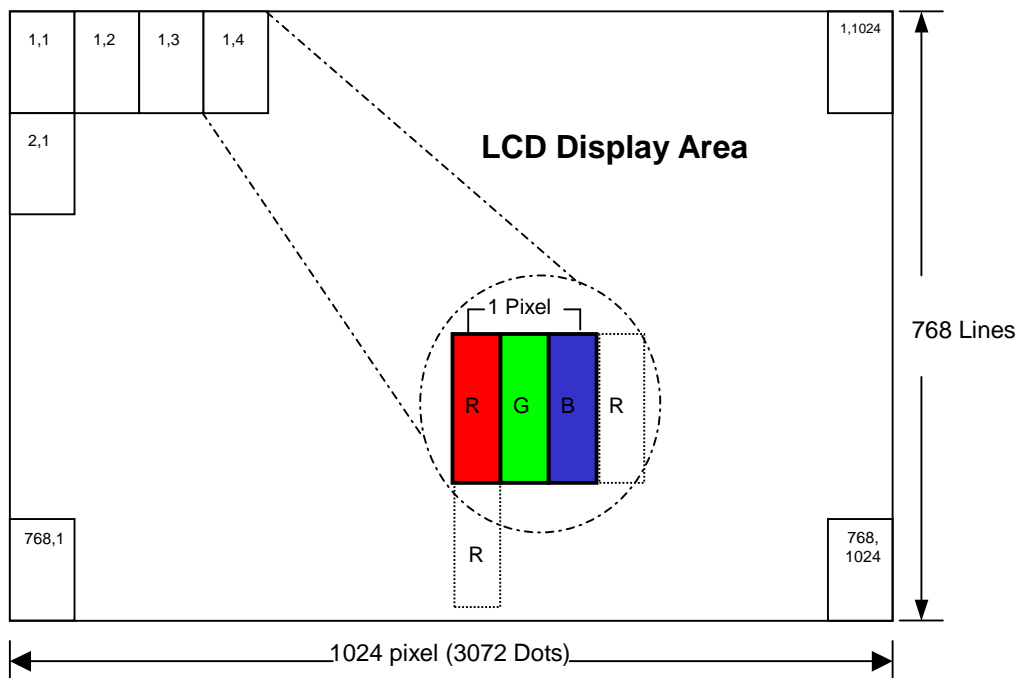



Document Title	HSD100PXN1-A00-C10 Tentative Specification	Page No.	11/27
Document No.		Revision	1.1

4.3 Relationship Between Displayed Color and Input

Display	MSB						LSB						MSB						LSB						Gray scale level
	R5	R4	R3	R2	R1	R0	G5	G4	G3	G2	G1	G0	B5	B4	B3	B2	B1	B0							
Basic color	Black	L	L	L	L	L	L	L	L	L	L	L	L	L	L	L	L	L	L	-					
	Blue	L	L	L	L	L	L	L	L	L	L	L	L	H	H	H	H	H	H	-					
	Green	L	L	L	L	L	L	H	H	H	H	H	H	L	L	L	L	L	L	-					
	Light Blue	L	L	L	L	L	L	H	H	H	H	H	H	H	H	H	H	H	H	-					
	Red	H	H	H	H	H	H	L	L	L	L	L	L	L	L	L	L	L	L	-					
	Purple	H	H	H	H	H	H	L	L	L	L	L	L	H	H	H	H	H	H	-					
	Yellow	H	H	H	H	H	H	H	H	H	H	H	H	L	L	L	L	L	L	-					
	White	H	H	H	H	H	H	H	H	H	H	H	H	H	H	H	H	H	H	-					
Gray scale of Red	Black	L	L	L	L	L	L	L	L	L	L	L	L	L	L	L	L	L	L	L0					
	Dark ↑ ↓ Light	L	L	L	L	L	H	L	L	L	L	L	L	L	L	L	L	L	L	L1					
		L	L	L	L	H	L	L	L	L	L	L	L	L	L	L	L	L	L	L2					
		⋮	⋮	⋮	⋮	⋮	⋮	⋮	⋮	⋮	⋮	⋮	⋮	⋮	⋮	⋮	⋮	⋮	⋮	⋮	L3...L60				
		H	H	H	H	L	H	L	L	L	L	L	L	L	L	L	L	L	L	L61					
	H	H	H	H	H	L	L	L	L	L	L	L	L	L	L	L	L	L	L62						
	Red	H	H	H	H	H	H	L	L	L	L	L	L	L	L	L	L	L	L	Red L63					
	Gray scale of Green	Black	L	L	L	L	L	L	L	L	L	L	L	L	L	L	L	L	L	L	L0				
Dark ↑ ↓ Light		L	L	L	L	L	L	L	L	L	L	L	H	L	L	L	L	L	L	L1					
		L	L	L	L	L	L	L	L	L	L	L	H	L	L	L	L	L	L	L2					
		⋮	⋮	⋮	⋮	⋮	⋮	⋮	⋮	⋮	⋮	⋮	⋮	⋮	⋮	⋮	⋮	⋮	⋮	⋮	L3...L60				
		L	L	L	L	L	L	H	H	H	H	L	H	L	L	L	L	L	L	L61					
L		L	L	L	L	L	H	H	H	H	H	L	L	L	L	L	L	L	L62						
Green		L	L	L	L	L	L	H	H	H	H	H	H	L	L	L	L	L	L	Green L63					
Gray scale of Blue		Black	L	L	L	L	L	L	L	L	L	L	L	L	L	L	L	L	L	L	L0				
	Dark ↑ ↓ Light	L	L	L	L	L	L	L	L	L	L	L	L	L	L	L	L	L	H	L1					
		L	L	L	L	L	L	L	L	L	L	L	L	L	L	L	L	H	L	L2					
		⋮	⋮	⋮	⋮	⋮	⋮	⋮	⋮	⋮	⋮	⋮	⋮	⋮	⋮	⋮	⋮	⋮	⋮	⋮	L3...L60				
		L	L	L	L	L	L	L	L	L	L	L	L	H	H	H	H	L	H	L61					
	L	L	L	L	L	L	L	L	L	L	L	L	H	H	H	H	H	L	L62						
	Blue	L	L	L	L	L	L	L	L	L	L	L	L	H	H	H	H	H	H	Blue L63					
	Gray scale of White & Black	Black	L	L	L	L	L	L	L	L	L	L	L	L	L	L	L	L	L	L	L0				
Dark ↑ ↓ Light		L	L	L	L	L	H	L	L	L	L	L	H	L	L	L	L	L	H	L1					
		L	L	L	L	H	L	L	L	L	L	H	L	L	L	L	L	H	L	L2					
		⋮	⋮	⋮	⋮	⋮	⋮	⋮	⋮	⋮	⋮	⋮	⋮	⋮	⋮	⋮	⋮	⋮	⋮	⋮	L3...L60				
		H	H	H	H	L	H	H	H	H	H	L	H	H	H	H	H	L	H	L61					
H		H	H	H	H	L	H	H	H	H	H	L	H	H	H	H	H	L	L62						
White	H	H	H	H	H	H	H	H	H	H	H	H	H	H	H	H	H	H	White L63						

Document Title	HSD100PXN1-A00-C10 Tentative Specification	Page No.	12/27
Document No.		Revision	1.1

5.0 INTERFACE PIN CONNECTION

5.1 TFT LCD Module : CN1 (Input signal): 093F30-B0B01A (Starconn or equivalent)

Pin No.	Signal	Description
1	CABC_EN	CABC enable
2	VDD	3.3V Power
3	VDD	3.3V Power
4	V_EDID	3.3V Power for EDID
5	ADJ	Adjust for LED brightness Note +3.3V
6	CLK_EDID	EDID Clock Input
7	DATA_EDID	EDID Data Input
8	RXIN0-	LVDS Signal - channel0-
9	RXIN0+	LVDS Signal+ channel0+
10	GND	Ground
11	RXIN1-	Data Input channel1-
12	RXIN1+	Data Input channel1+
13	GND	Ground
14	RXIN2-	Data Input channel2-
15	RXIN2+	Data Input channel2+
16	GND	Ground
17	RXCLKIN-	Data Input CLK-
18	RXCLKIN+	Data Input CLK+
19	GND	Ground
20	NC	NC
21	NC	NC
22	GND	Ground (SYS+TP)
23	GND	Ground (SYS+TP)
24	VLED	LED Power +5V
25	VLED	LED Power +5V
26	VLED	LED Power +5V
27	USB D-	-USB differential data
28	USB D+	+USB differential data
29	NC	NC
30	Function	Function (NA)

Note : The brightness of LCD panel could be changed by adjusting PWM

Document Title	HSD100PXN1-A00-C10 Tentative Specification	Page No.	13/27
Document No.		Revision	1.1

[Note]

(1) ADJ can adjust brightness to control Pin. Pulse duty the bigger the brighter.

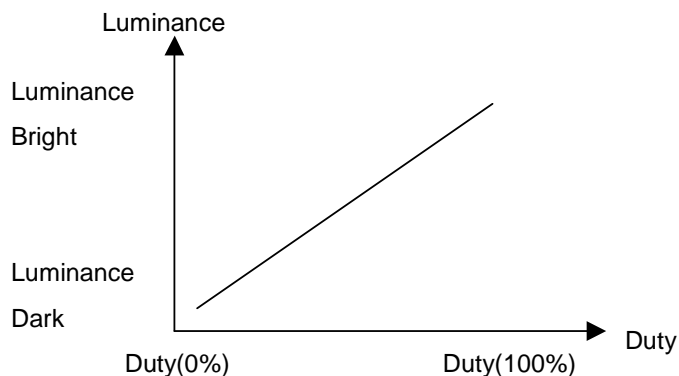

(2) ADJ Signal=0~3.3V · Operation Conditions :

Parameter	Symbol	Conditions	Min	Typ	Max	Unit
ADJ Logic-High Level	V _{ADJH}		1.8	3.3	3.6	V
ADJ Logic-Low Level	V _{ADJL}		0	0	0.4	V
Dimming Frequency	F _{ADJ}		18	20	22	kHz
Dimming Duty Cycle	D		20	--	100	%

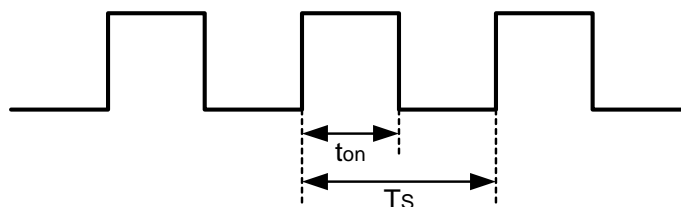

$$D = t_{on} / T_s \times 100\%$$

$$F_{ADJ} = 1 / T_s$$

(3) CABC_EN · Operation Conditions :

Parameter	Symbol	Min	Typ	Max	Units	Remark
CABC on/off signal (control CABC Function on/off)	CABC_EN (H)	3.0	3.3	3.6	Volt	CABC on
	CABC_EN (L)	--	0	0.2		CABC off

Document Title	HSD100PXN1-A00-C10 Tentative Specification	Page No.	14/27
Document No.		Revision	1.1

6.0 ELECTRICAL CHARACTERISTICS

6.1 TFT LCD Module

Item	Symbol	Min.	Typ.	Max.	Unit	Note
Supply Voltage	V_{DD}	3.0	3.3	3.6	V	Note (1)
Current of power supply	I_{DD}	-	0.3	-	A	$V_{DD}=3.3V$ 、L0 pattern $T_a=25^{\circ}C$ $f_v=60Hz$
Inrush current	I_{RUSH}	-	-	1.50	A	Note (2)

Note (1): V_{DD} -dip condition:

When V_{DD} operating within $2.7V \leq V_{DD} < 3.0V$, $t_d \leq 10ms$, the display may momentarily become abnormal.

$V_{DD} < 2.7V$, V_{DD} dip condition should also follow the Power On/Off conditions for supply voltage.

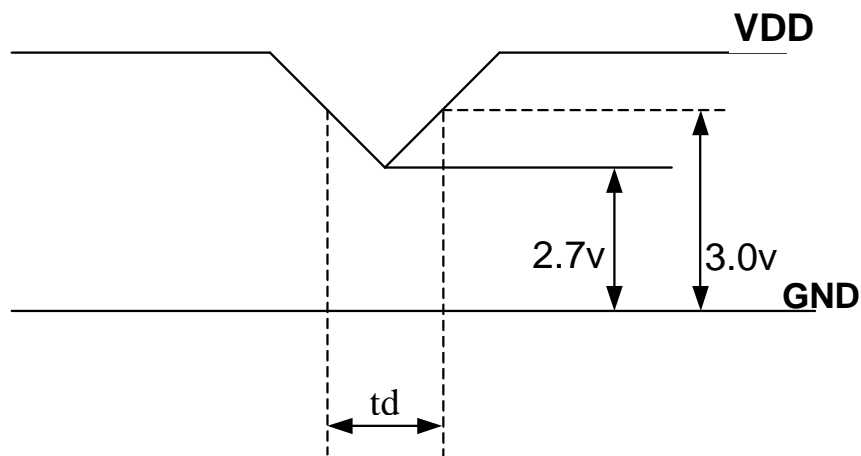

Document Title	HSD100PXN1-A00-C10 Tentative Specification	Page No.	15/27
Document No.		Revision	1.1

Note : (2) Power on Inrush current test circuit

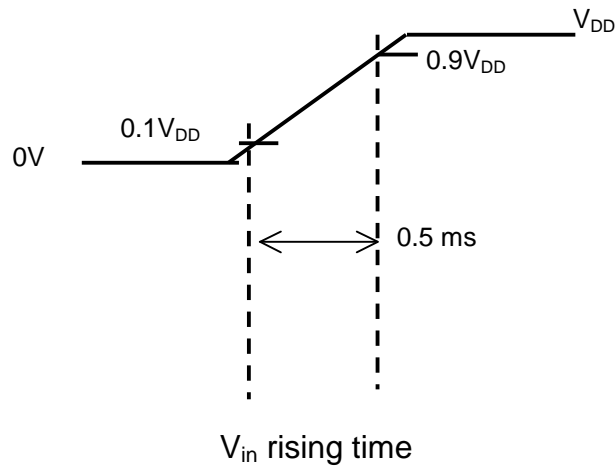
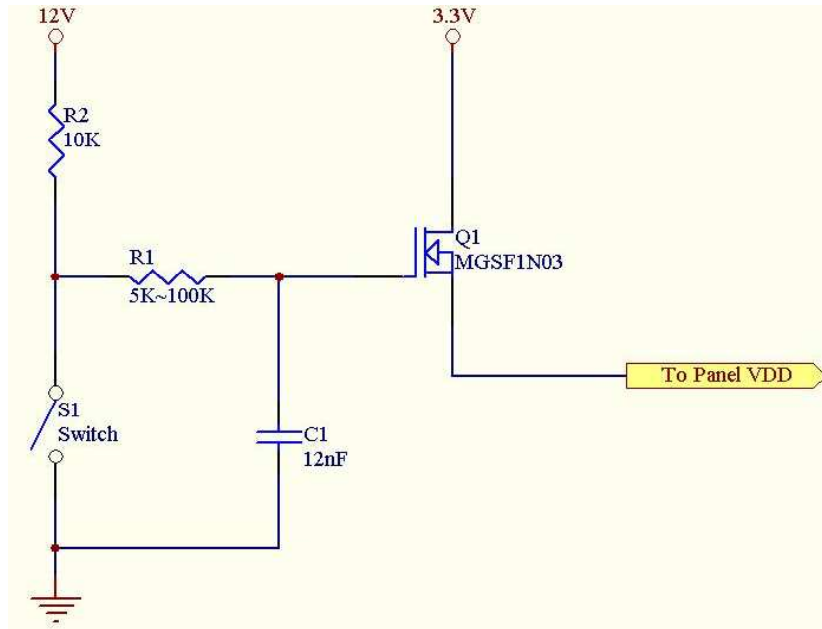

Document Title	HSD100PXN1-A00-C10 Tentative Specification	Page No.	16/27
Document No.		Revision	1.1

6.2 Switching Characteristics for LVDS Receiver

Item	Symbol	Min.	Typ.	Max.	Unit	Conditions
Differential Input High Threshold	V _{th}	—	—	100	mV	V _{CM} =1.2V
Differential Input Low Threshold	V _{tl}	-100	—	—	mV	
Input Current	I _{IN}	-10	—	+10	uA	
Differential input Voltage	V _{ID}	0.1	—	0.6	V	
Common Mode Voltage Offset	V _{CM}	(V _{ID} /2)	1.25	1.8-0.4-(V _{ID} /2)	V	

6.3 Bit Mapping & Interface Definition

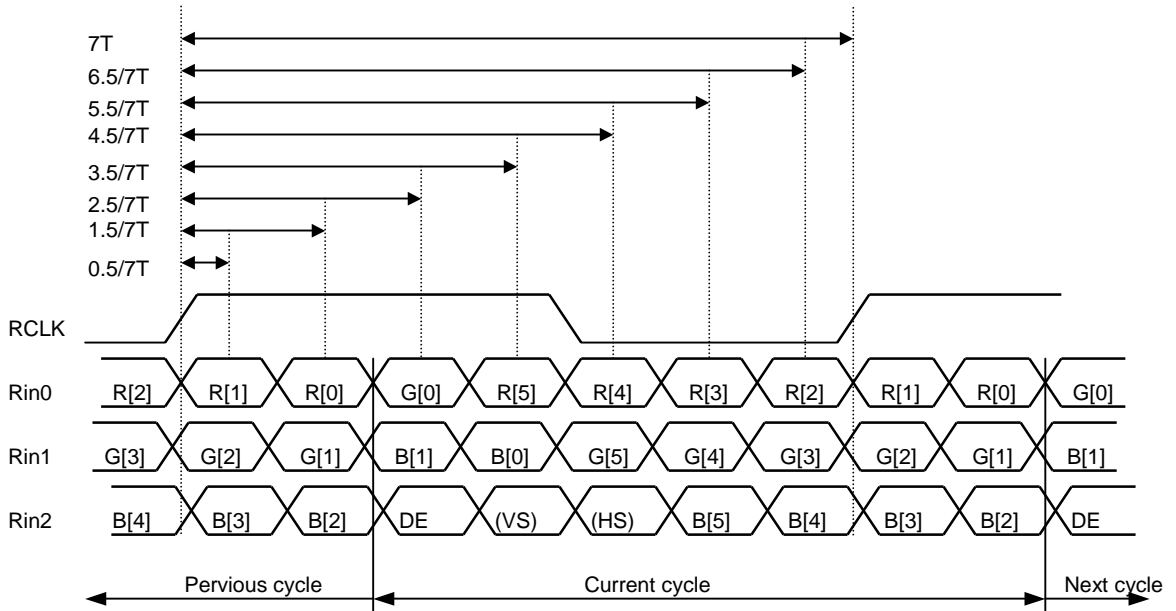

LVDS Receiver Input Timing Definition
for 6bits LVDS input

Document Title	HSD100PXN1-A00-C10 Tentative Specification	Page No.	17/27
Document No.		Revision	1.1

6.4 Interface Timing (DE mode)

Item	Symbol	Min.	Typ.	Max.	Unit
Frame Rate	--	55	60	65	Hz
Frame Period	t1	793	806	819	line
Vertical Display Time	t2	768	768	768	line
Vertical Blanking Time	t3	25	38	51	line
1 Line Scanning Time	t4	1304	1344	1384	clock
Horizontal Display Time	t5	1024	1024	1024	clock
Horizontal Blanking Time	t6	280	320	360	clock
Clock Rate	t7	55	65	75	MHz

Timing Diagram of Interface Signal (DE mode)

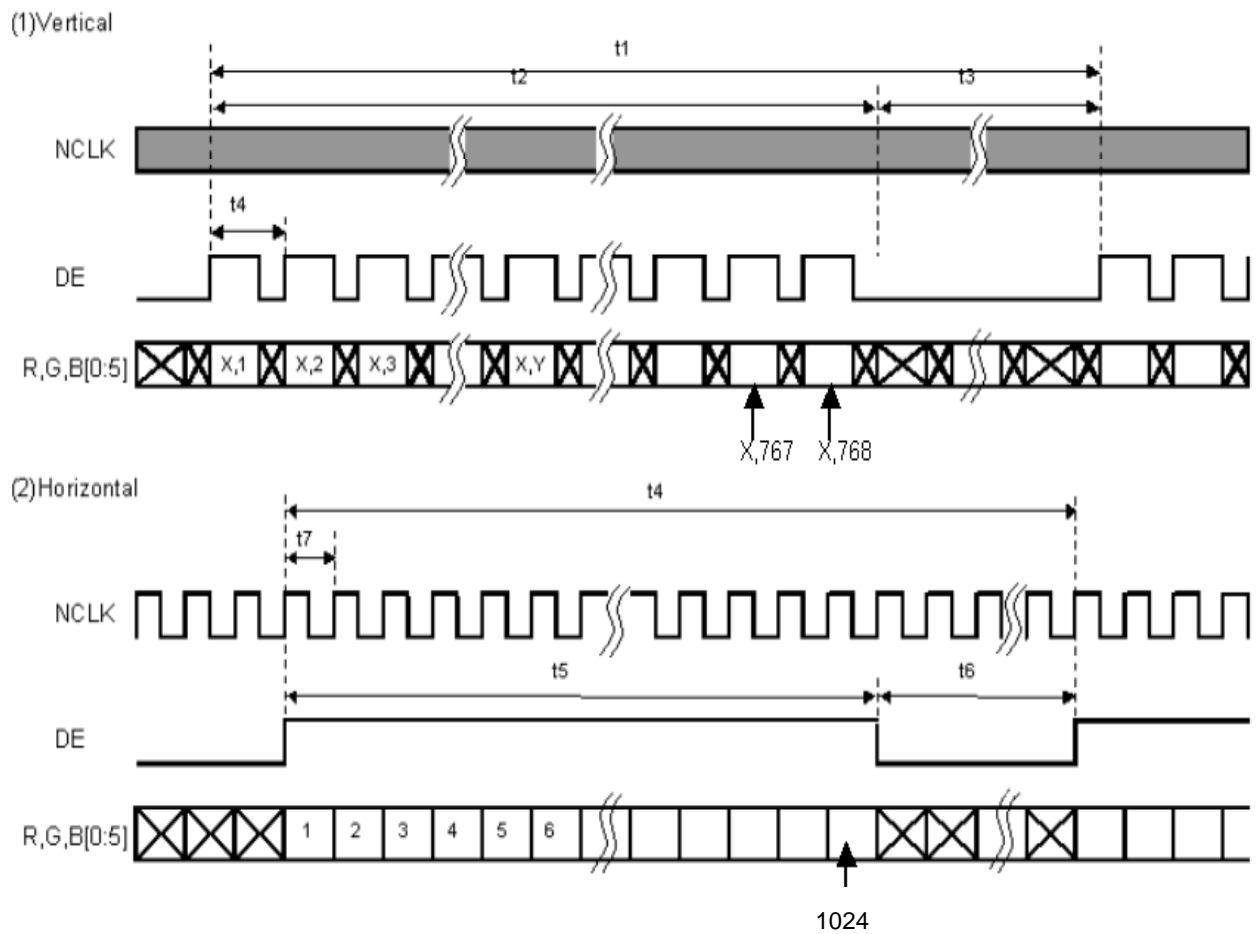

Document Title	HSD100PXN1-A00-C10 Tentative Specification	Page No.	18/27
Document No.		Revision	1.1

6.5 Power On / Off Sequence

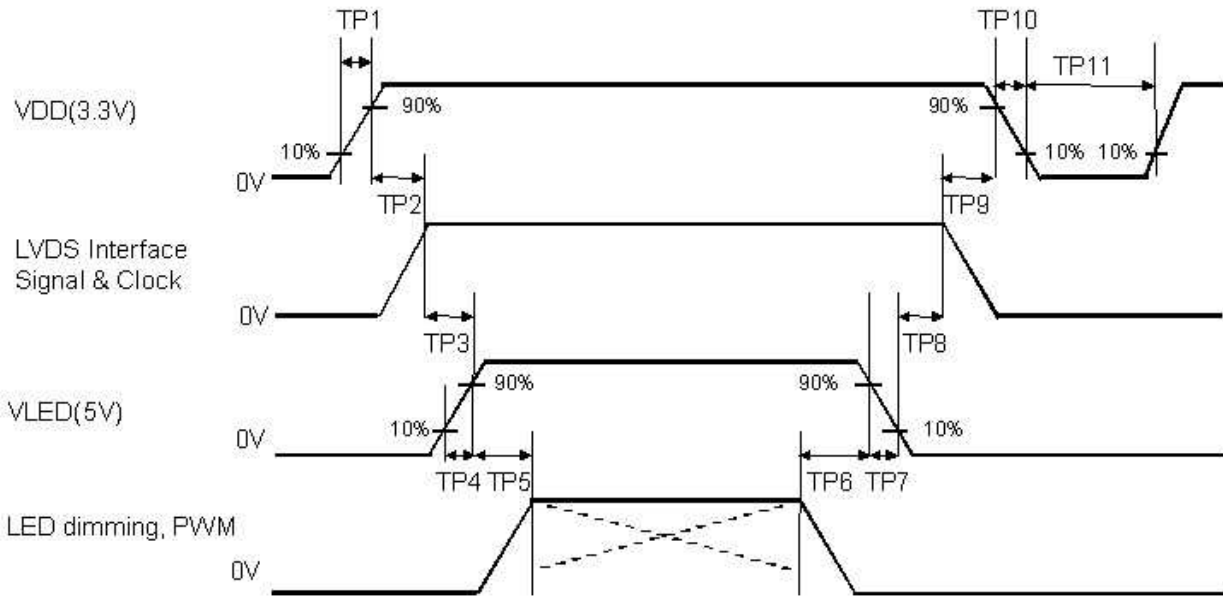

Item	Min.	Typ.	Max.	Unit	Remark
TP1	0.5	--	10	msec	
TP2	0	--	50	msec	
TP3	200	--	--	msec	
TP4	0.5	--	10	msec	
TP5	10	--	--	msec	
TP6	10	--	--	msec	
TP7	0	--	10	msec	
TP8	200	--	--	msec	
TP9	0	--	50	msec	
TP10	1	--	10	msec	
TP11	1000	--	--	msec	

Document Title	HSD100PXN1-A00-C10 Tentative Specification	Page No.	19/27
Document No.		Revision	1.1

- Note :**
- (1) The supply voltage of the external system for the module input should be the same as the definition of V_{DD} .
 - (2) Apply the lamp voltage within the LCD operation range. When the back-light turns on before the LCD operation or the LCD turns off before the back-light turns off, the display may momentarily become white.
 - (3) In case of V_{DD} = off level, please keep the level of input signal on the low or keep a high impedance.
 - (4) TP11 should be measured after the module has been fully discharged between power off and on period.
 - (5) Interface signal shall not be kept at high impedance when the power is on.
 - (6) The duty of LED dimming signal should be more than 20% in TP4 and TP5
 - (7) PWM can adjust brightness to control Pin. Pulse duty the bigger the brighter

6.6 Backlight Unit

Parameter	Symbol	Min	Typ	Max	Units	Condition
LED Current	I_F	--	20	20.6	mA	$T_a=25^{\circ}C$
LED Voltage	V_F	3.1	3.3	3.5	Volt	$T_a=25^{\circ}C$
LED Power consumption	P_{LED}	--	1.63	1.73	Watt	$T_a=25^{\circ}C$ Note (1)
LED Life-Time	N/A	10,000	--	--	Hour	$T_a=25^{\circ}C$ $I_F=20mA$ Note (2)

Note (1): Calculator value for reference $P=I_F \times V_F \times N$ (LED Qty')

Note (2): The LED lifetime defines as the estimated time to 50% degradation of final luminous.

Document Title	HSD100PXN1-A00-C10 Tentative Specification	Page No.	20/27
Document No.		Revision	1.1

6.7 LED Driver

6.7.1 Absolute Maximum Ratings

Item	Symbol	Min.	Max.	Unit	Note
LED Power Supply voltage	V_{LED}	-0.3	6	Volt	
LED_EN, PWM pin Voltage	V_{EN}, V_{PWM}	--	5.5	Volt	

6.7.2 DC Electrical Characteristics

Parameter	Symbol	Min	Typ	Max	Units	Remark
LED Power Supply Voltage	V_{LED}	4.5	--	5.5	Volt	
PWM High Threshold	V_{PWMH}	3.0	--	--	Volt	
PWM Low Threshold	V_{PWML}	--	--	0.2	Volt	

6.8 CABC DC Electrical Characteristics

Parameter	Symbol	Min	Typ	Max	Units	Remark
CABC_EN High Threshold	V_{CABCH}	$0.7V_{DD}$	--	--	Volt	
CABC_EN Low Threshold	V_{CABCL}	--	--	$0.3V_{DD}$	Volt	

Document Title	HSD100PXN1-A00-C10 Tentative Specification	Page No.	21/27
Document No.		Revision	1.1

7.0 Reliability test items

No.	Item	Conditions	Remark
1	High Temperature Storage	Ta=+60°C, 240hrs	
2	Low Temperature Storage	Ta=-20°C, 240hrs	
3	High Temperature Operation	Ta=+50°C, 500hrs	
4	Low Temperature Operation	Ta=0°C, 500hrs	
5	Thermal Cycling Test (non operation)	-20°C(30min)→+60°C(30min),100 cycles	
6	Vibration	Sine Wave 1.5G, 5~500Hz, XYZ 30min/each direction	
7	Shock	Half-Sine, 200G, 2ms, ±XYZ, 1time	

Storage / Operating temperature

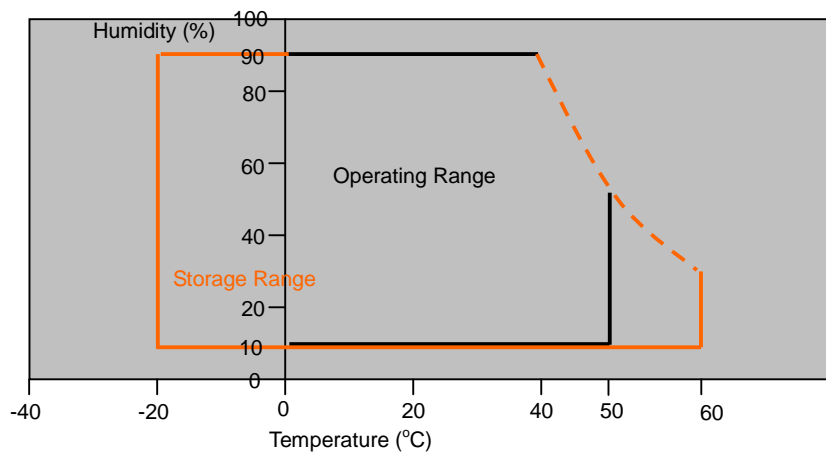

Note .Max wet bulb temp.=39°C

Document Title	HSD100PXN1-A00-C10 Tentative Specification	Page No.	22/27
Document No.		Revision	1.1

8.0 OUTLINE DIMENSION

8.1 Front View Outline Dimension

Unit : mm

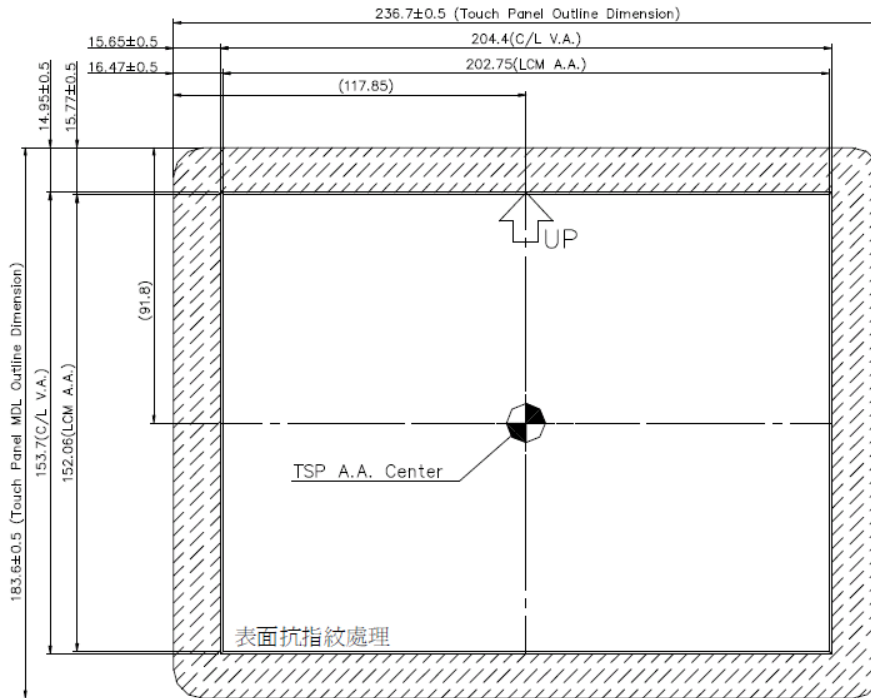

Front Side

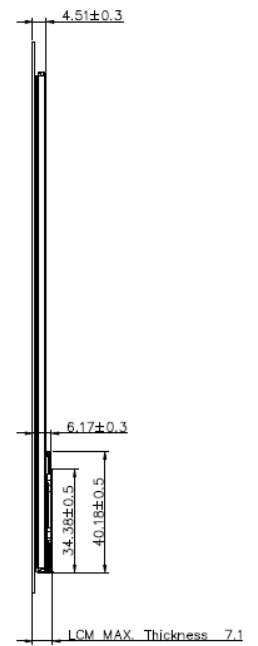

Document Title	HSD100PXN1-A00-C10 Tentative Specification	Page No.	23/27
Document No.		Revision	1.1

8.2 Back View Outline Dimension

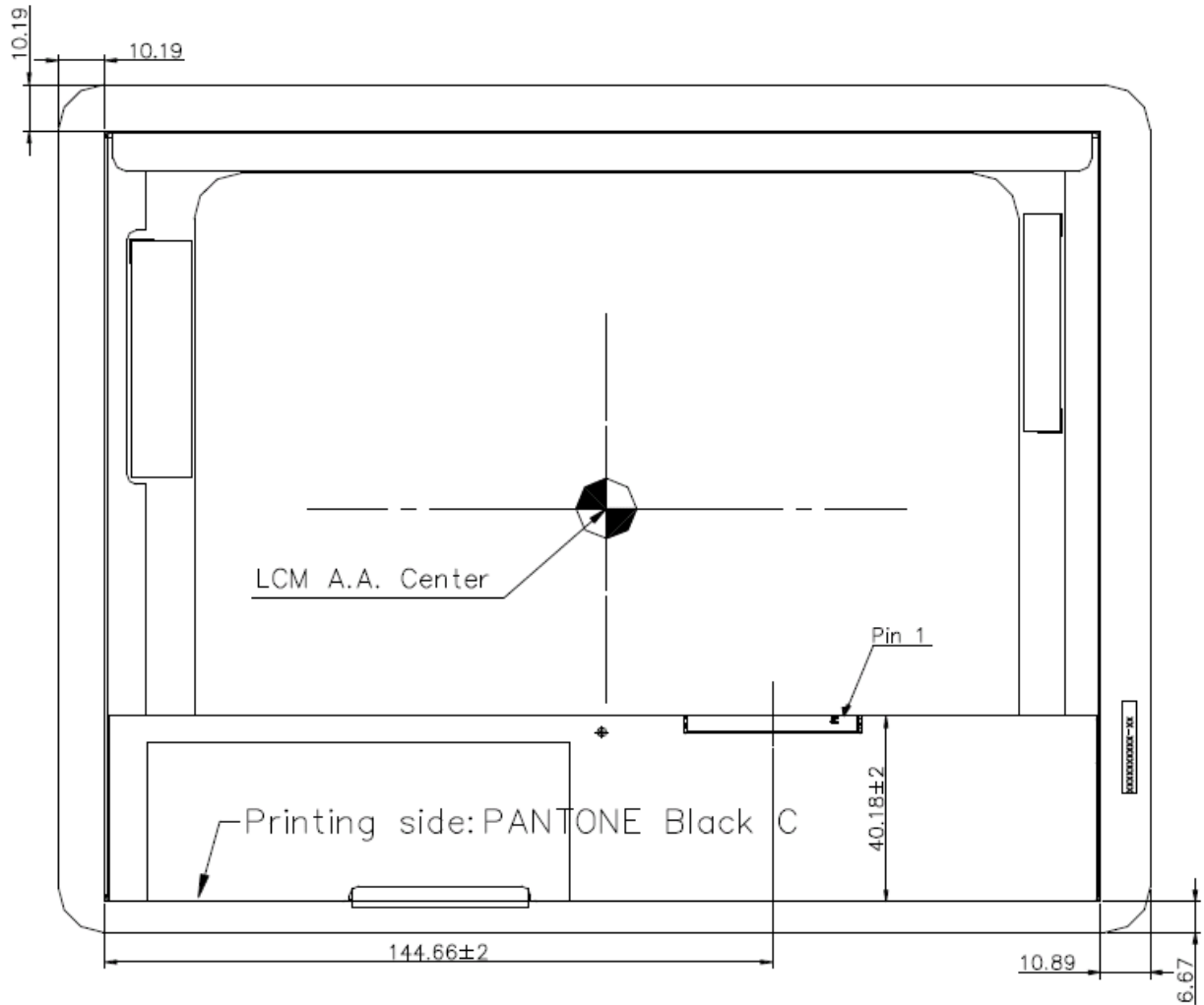

Document Title	HSD100PXN1-A00-C10 Tentative Specification	Page No.	24/27
Document No.		Revision	1.1

9.0 LOT MARK

9.1 Lot Mark

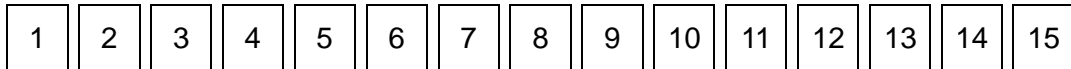

Code 1,2,3,4,5,6: HannStar internal flow control code.

Code 7: production location.

Code 8: production year.

Code 9: production month.

Code 10,11,12,13,14,15: serial number.

Note (1) Production Year

Year	2006	2007	2008	2009	2010	2011	2012	2013	2014	2015
Mark	6	7	8	9	0	1	2	3	4	5

Note (2) Production Month

Month	Jan.	Feb.	Mar.	Apr.	May.	Jun.	Jul.	Aug.	Sep.	Oct	Nov.	Dec.
Mark	1	2	3	4	5	6	7	8	9	A	B	C

9.2 Location of Lot Mark

- (1) Location : The label is attached to the backside of the LCD module. See Product back view. (Section 8.0 : OUTLINE DIMENSION)
- (2) Detail of the Mark : As attached below
- (3) This is subject to change without prior notice.

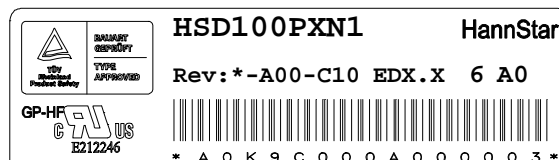

Document Title	HSD100PXN1-A00-C10 Tentative Specification	Page No.	25/27
Document No.		Revision	1.1

10.0 PACKAGE SPECIFICATION

10.1 Packing form

LCM Model	LCM Qty. in the box	Inner Box Size (mm)	Notice
HSD100PXN1-A00-C1	24pcs/box	473 x 348 x 303 ^H	

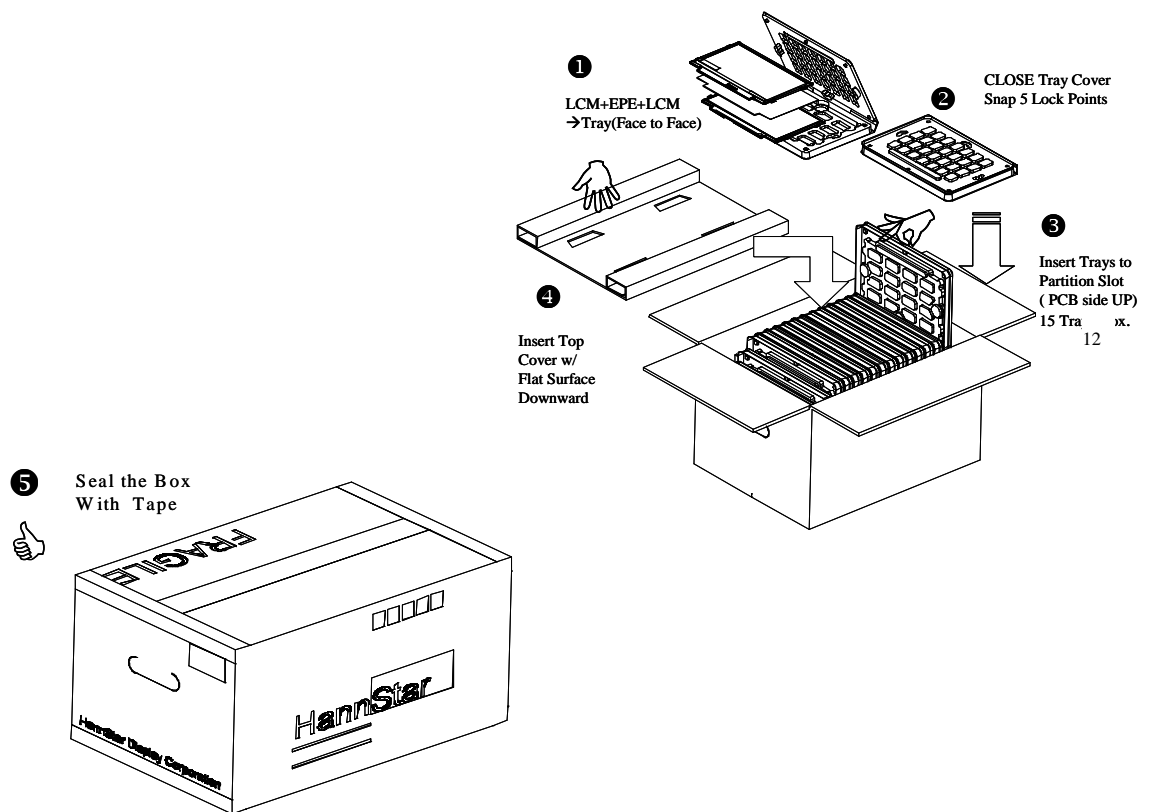

Document Title	HSD100PXN1-A00-C10 Tentative Specification	Page No.	26/27
Document No.		Revision	1.1

10.2 Packing assembly drawings

HSD100PXN1-A00-C10	Material	Notice
Box	Corrugated Paper Board	AB Flute
Partition/Pad	Corrugated Paper Board	B Flute
Corner Pad	Corrugated Paper Board	B Flute
Tray	PE	--
EPE	PET	--

11.0 GENERAL PRECAUTION

11.1 Use Restriction

This product is not authorized for use in life supporting systems, aircraft navigation control systems, military systems and any other application where performance failure could be life-threatening or otherwise catastrophic.

11.2 Disassembling or Modification

Do not disassemble or modify the module. It may damage sensitive parts inside LCD module, and may cause scratches or dust on the display. HannStar does not warrant the module, if customers disassemble or modify the module.

11.3 Breakage of LCD Panel

11.3.1. If LCD panel is broken and liquid crystal spills out, do not ingest or inhale liquid crystal, and do not contact liquid crystal with skin.

11.3.2. If liquid crystal contacts mouth or eyes, rinse out with water immediately.

11.3.3. If liquid crystal contacts skin or cloths, wash it off immediately with alcohol and rinse thoroughly with water.

11.3.3. Handle carefully with chips of glass that may cause injury, when the glass is broken.

11.4 Electric Shock

11.4.1. Disconnect power supply before handling LCD module.

11.4.2. Do not pull or fold the LED cable.

11.4.3. Do not touch the parts inside LCD modules and the fluorescent LED's connector or cables in order to prevent electric shock.

Document Title	HSD100PXN1-A00-C10 Tentative Specification	Page No.	27/27
Document No.		Revision	1.1

11.5 Absolute Maximum Ratings and Power Protection Circuit

- 11.5.1. Do not exceed the absolute maximum rating values, such as the supply voltage variation, input voltage variation, variation in parts' parameters, environmental temperature, etc., otherwise LCD module may be damaged.
- 11.5.2. Please do not leave LCD module in the environment of high humidity and high temperature for a long time.
- 11.5.3. It's recommended to employ protection circuit for power supply.

11.6 Operation

- 11.6.1. Do not touch, push or rub the polarizer with anything harder than HB pencil lead.
- 11.6.2. Use fingerstalls of soft gloves in order to keep clean display quality, when persons handle the LCD module for incoming inspection or assembly.
- 11.6.3. When the surface is dusty, please wipe gently with absorbent cotton or other soft material.
- 11.6.4. Wipe off saliva or water drops as soon as possible. If saliva or water drops contact with polarizer for a long time, they may causes deformation or color fading.
- 11.6.5. When cleaning the adhesives, please use absorbent cotton wetted with a little petroleum benzine or other adequate solvent.

11.7 Mechanism

Please mount LCD module by using mounting holes arranged in four corners tightly.

11.8 Static Electricity

- 11.8.1. Protection film must remove very slowly from the surface of LCD module to prevent from electrostatic occurrence.
- 11.8.2. Because LCD module use CMOS-IC on circuit board and TFT-LCD panel, it is very weak to electrostatic discharge. Please be careful with electrostatic discharge. Persons who handle the module should be grounded through adequate methods.

11.9 Strong Light Exposure

The module shall not be exposed under strong light such as direct sunlight. Otherwise, display characteristics may be changed.

11.10 Disposal

When disposing LCD module, obey the local environmental regulations.