

mass integrated

global part distribution • product lifecycle partner
excess inventory management • value-ad service provider



Data sheet provided by Mass Integrated

massintegrated.com • displayalliance.com

Please call +1.978.465.6190
Email: sales@massintegrated.com



ISO 9001: 2008

Mass Integrated complies with all DMCA takedown notices. Please send a formal DMCA Takedown Notice to Mass Integrated Systems, Inc. • 18 Henry Graf Jr. Road, Unit 1 • Newburyport, MA 01950.



PROPRIETARY NOTE

THIS SPECIFICATION IS THE PROPERTY OF HYDIS AND SHALL NOT BE REPRODUCED OR COPIED WITHOUT THE WRITTEN PERMISSION OF HYDIS AND MUST BE RETURNED TO HYDIS UPON ITS REQUEST

TITLE : HX104X01-210
Product Specification
Rev. 0

HYDIS Technologies

SPEC. NUMBER S864-1380	PRODUCT GROUP TFT-LCD PRODUCTS	REV. 0	ISSUE DATE 2009.04.01	PAGE 1 / 30
---------------------------	-----------------------------------	-----------	--------------------------	----------------

B2005-C001-C(1/3)

A4(210 x 297)

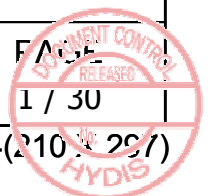



PRODUCT GROUP

REV

ISSUE DATE

TFT-LCD PRODUCT

0

2009.04.01

REVISION HISTORY

REV.	ECN NO.	DESCRIPTION OF CHANGES	DATE	PREPARED
0		Initial Release	09.04.01	H.R.Park

SPEC. NUMBER
S864-1380

SPEC. TITLE
HX104X01-210 Product Specification

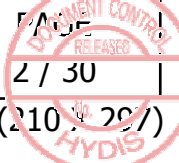

B2005-C001-C(2/3)

A4(210 x 297)



PRODUCT GROUP

REV

ISSUE DATE

TFT-LCD PRODUCT

0

2009.04.01

CONTENS

NO.	ITEM	PAGE
1.0	General Description	4
2.0	Absolute Maximum ratings	6
3.0	Electrical specifications	7
4.0	Optical specifications	9
5.0	Interface Connection	11
6.0	Signal Timing Specification	15
7.0	Signal Timing waveforms of interface signal (DE mode)	16
8.0	Input Signals, Display Colors & Gray Scale of Colors	17
9.0	Power Sequence	18
10.0	Mechanical Characteristics	19
11.0	Reliability Test	20
12.0	Packing Specifications	21
13.0	Handling & Cautions	24
14.0	EDID Data	25
15.0	Appendix	27

SPEC. NUMBER
S864-1380

SPEC. TITLE
HX104X01-210 Product Specification

PAGE
3 / 30

B2005-C001-C(3/3)

A4(210 x 297)

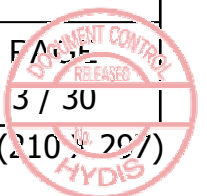

1.0 GENERAL DESCRIPTION

1.1 Introduction

10.4" AFFS+ TFT-LCD is a color active matrix TFT LCD module using amorphous silicon TFT's (Thin Film Transistors) as active switching devices. This module has a 10.4 inch diagonally measured active area with XGA resolutions (1024 horizontal by 768 vertical pixel array). Each pixel is divided into RED, GREEN, BLUE dots which are arranged in vertical stripe and this module can display 262,144 colors. The TFT-LCD panel used for this module is a low reflection and higher color type.

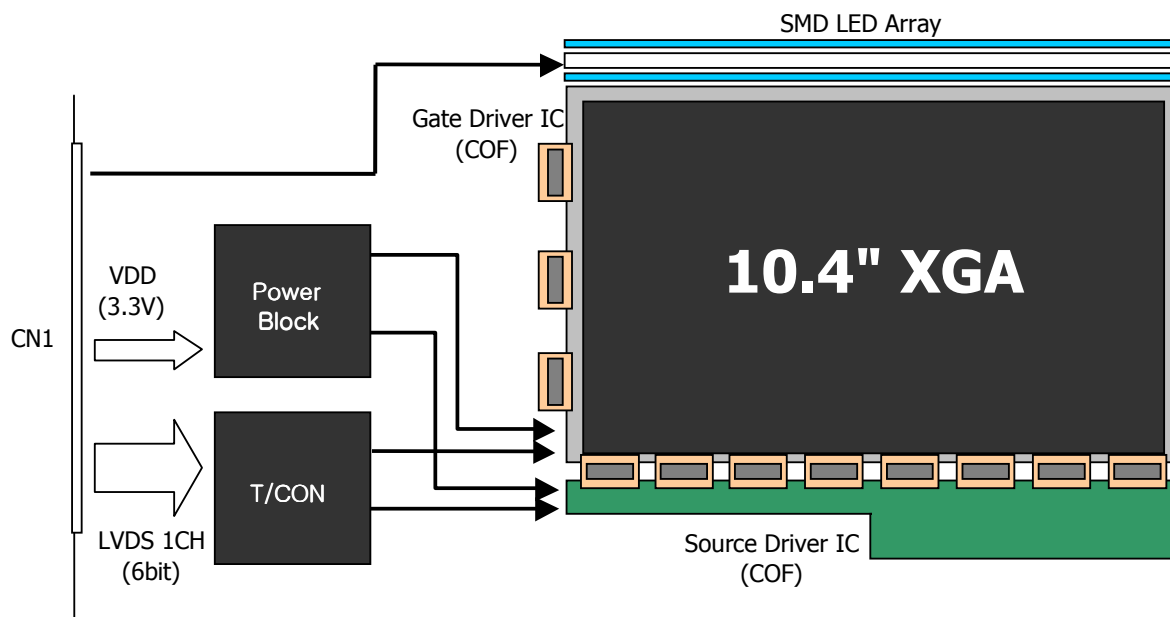

1.2 Features

- 1Ch LVDS Interface with 1 pixel / clock
- 6-bit color depth, Display 262,144 colors
- High luminance and contrast ratio, low reflection and wide viewing angle
- Front Mounting Frame
- DE (Data Enable) mode only
- SLG (Single Level Gate) function use
- RoHS Product
- SMD LED Array
- On board EDID

1.3 Application

- Pen type & Tablet PC

SPEC. NUMBER
S864-1380

SPEC. TITLE
HX104X01-210 Product Specification

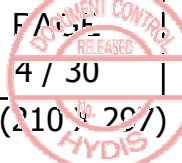
 PAGE
4 / 30
A4(210 x 297)
HYDIS



PRODUCT GROUP

REV

ISSUE DATE

TFT-LCD PRODUCT

0

2009.04.01

1.3 General Specifications

PARAMETER	SPECIFICATION	UNIT	REMARK
Active area	210.432 X 157.824	mm	
Number of pixels	1024(H) × 768(V)	pixels	
Pixel pitch	0.2055(H) × 0.2055(V)	mm	
Pixel arrangement	RGB Vertical stripe		
Display colors	262,144	colors	
Display mode	Normally Black		
Dimensional outline	238.6±0.5(H) X 173.2±0.5(V) X 4.3max	mm	Note 1
Weight	210 Typ. / 220 Max.	gram	
Back-light	SMD LED Array		
Surface treatment	Anti-Glare		

Note : 1. LCM Height : 4.3mm max. (LED), 6.8mm max. (Component)

SPEC. NUMBER
S864-1380

SPEC. TITLE
HX104X01-210 Product Specification

FACE
5 / 30

B2005-C001-C(3/3)

A4(210 X 297)

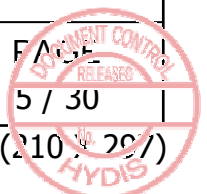

**HYDIS****PRODUCT GROUP**

REV

ISSUE DATE

TFT-LCD PRODUCT

0

2009.04.01

2.0 ABSOLUTE MAXIMUM RATINGS

The followings are maximum values which, if exceed, may cause faulty operation or damage to the unit.

PARAMETER		SYMBOL	MIN.	MAX.	UNIT	REMARK
Logic Power Supply		V_{DD}	VSS-0.3	4.0	V	Ta = 25 ± 2 °C
Logic Input Voltage		V_{IN}	VSS-0.3	$V_{DD}+0.3$	V	
Back-light Power Supply Voltage		HVDD	-0.3	40	V	
Back-light LED Current	25°C	I_{LED}	-	30	mA	
	50°C	I_{LED}	-	20	mA	
Back-light LED Reverse Voltage		V_R	-	5	V	
Operating Temperature		T_{OP}	-20	+70	°C	Note1

Note1. As compromised, T-Con and D-IC are excluded within the range of guarantee for Operating Temperature.

*T-CON : 0~70°C / D-IC : -10 ~ 75°C(Source) / -20 ~ 75°C(Gate)

SPEC. NUMBER
S864-1380

SPEC. TITLE
HX104X01-210 Product Specification

FACE
6 / 30

B2005-C001-C(3/3)

A4(210 × 297)

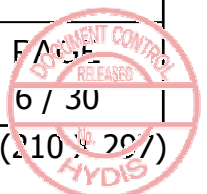



PRODUCT GROUP

REV

ISSUE DATE

TFT-LCD PRODUCT

0

2009.04.01

3.0 ELECTRICAL SPECIFICATIONS

3.1 Electrical Specifications

< Table 3. Electrical Specifications >

Parameter		Min.	Typ.	Max.	Unit	Remarks
Logic Power Supply Voltage	V_{DD}	3.0	3.3	3.6	V	Note 1
Logic Power Supply Current	I_{DD}	-	270	300	mA	Note 1
Back-light Power Supply Voltage	HV_{DD}	7.0	12.0	20	V	Note 2
Back-light Power Supply Current	I_{HVDD}	-	246	283	mA	Note 2, 3
Back-light Power Consumption	P_{BL}	-	2.95	3.39	W	Note 2, 3
LED Driver's Efficiency	η	-	82	-	%	Note 2, 3
Back-light PWM Frequency	F_{PWM}	200	320	350	Hz	
High Level PWM Signal Voltage	V_{PWMH}	2.1	3.3	5.0	V	
Low Level PWM Signal Voltage	V_{PWML}	-	0	0.6	V	
High Level Differential Input Signal Voltage	V_{IH}	-	-	+100	mV	$V_{CM} = 1.2V$
Low Level Differential Input Signal Voltage	V_{IL}	-100	-	-	mV	
Back-light LED Voltage / Back-light LED Total Voltage	V_{LED} / V_{BL}	-	3.2 / 22.4	3.4 / 23.8	V	Note 4
Back-light LED Current / Back-light LED Total Current	I_{LED} / I_{BL}	-	19.0 / 114.0	20.0 / 120.0	mA	Note 4
Life Time		12,000	-	-	Hrs	Note 6
Power Consumption	P_D	-	0.90	1.00	W	Note 1
	P_{LED}	-	2.55	2.85	W	Note 4
	P_{total}	-	3.45	3.85	W	Note 1, 4

SPEC. NUMBER
S864-1380

SPEC. TITLE
HX104X01-210 Product Specification

FACE
/ / 30

B2005-C001-C(3/3)

A4(210 / 297)
HYDIS

- Notes :
1. The supply voltage is measured and specified at the interface connector of LCM.
The current draw and power consumption specified is for 3.3V at 25°C.
a) Typ : Window XP pattern, b) Max : Vertical Sub line pattern
 2. The power supply voltage and current is measured and specified at the interface connector of LCM including LED Driver.
 3. Reference value, which is measured with LED Driver for 12V.
 4. Reference value, which is measured without LED Driver.
 5. Calculated value for reference ($V_{LED} \times I_{LED} \times \# \text{ of LEDs (42EA) }$).
 6. End of Life shall be determined by the time when any of the following is satisfied under continuous lighting at 25°C and $I_{LED} = 19.0\text{mA}$.
 - Intensity drops to 50% of the Initial Value (Luminance Spec.)
 - Based on LED

3.2 PWM Duty Ratio vs Brightness

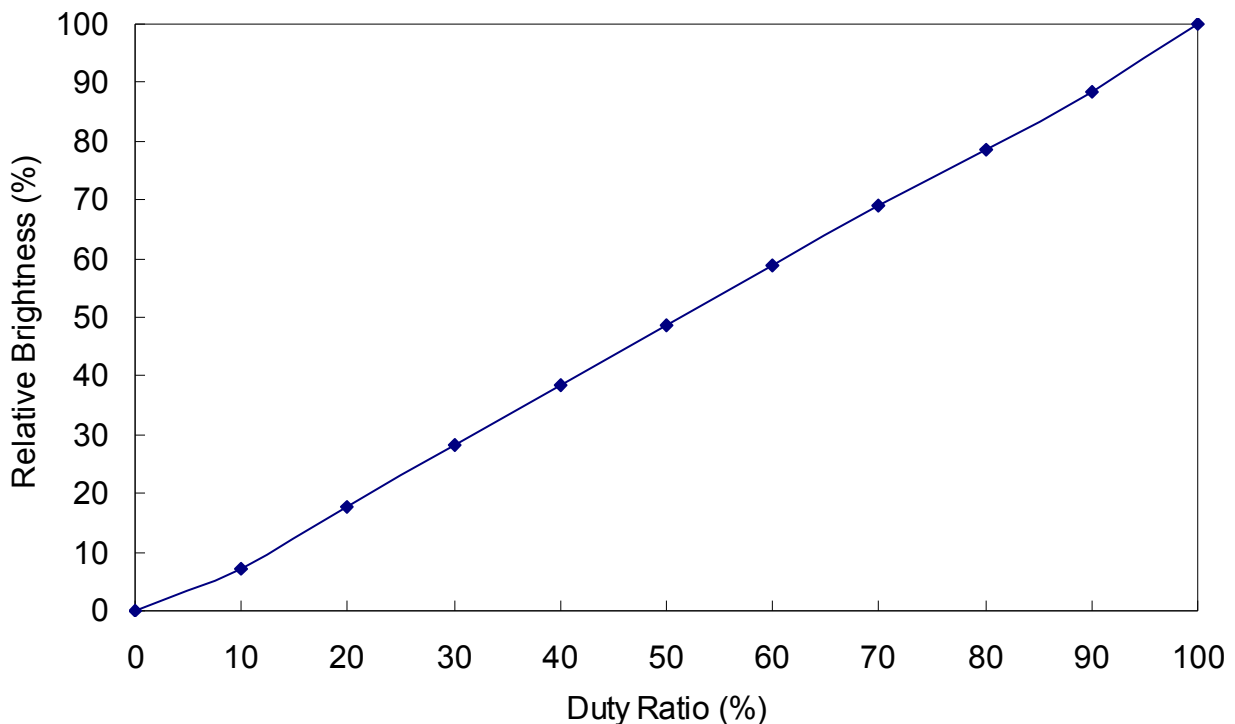

SPEC. NUMBER
S864-1380

SPEC. TITLE
HX104X01-210 Product Specification

FACE
8 / 30



PRODUCT GROUP

REV

ISSUE DATE

TFT-LCD PRODUCT

0

2009.04.01

4.0 OPTICAL SPECIFICATION

The test of Optical specifications shall be measured in a dark room (ambient luminance 1 lux and temperature = 25±2°C) with the equipment of Luminance meter system (Goniometer system and TOPCONE BM-5) and test unit shall be located at an approximate distance 50cm from the LCD surface at a viewing angle of θ and Φ equal to 0°. We refer to $\theta_{\phi=0}$ ($=\theta_3$) as the 3 o'clock direction (the right"), $\theta_{\phi=90}$ ($=\theta_{12}$) as the 12 o'clock direction ("upward"), $\theta_{\phi=180}$ ($=\theta_9$) as the 9 o'clock direction ("left") and $\theta_{\phi=270}$ ($=\theta_6$) as the 6 o'clock direction ("bottom"). While scanning θ and/or ϕ , the center of the measuring spot on the Display surface shall stay fixed. The backlight should be operating for 30 minutes prior to measurement. VDD shall be 3.3+/- 0.3V at 25°C. Optimum viewing angle direction is 6 o'clock.

PARAMETER		SYMBOL	CONDITION	MIN.	TYP.	MAX.	UNIT	REMARK
Viewing Angle Range	Horizontal	θ_3	CR > 10	-	89	90	Deg.	Note 1
		θ_9		-	89	90	Deg.	
	Vertical	θ_{12}		-	89	90	Deg.	
		θ_6		-	89	90	Deg.	
Luminance Contrast ratio		CR	$\theta = 0^\circ$	400	600	-		Note 2
Luminance of White	Center	Y_w	$\theta = 0^\circ$	250	300	-	cd/m ²	Note 3
White Luminance Uniformity	5 Points	$\Delta Y5$		80	-	-		Note 4
	13 Points	$\Delta Y13$		65	-	-		
White Chromaticity		x_w	$\theta = 0^\circ$	0.273	0.313	0.353		Note 5
		y_w		0.289	0.329	0.369		
Reproduction of Color	Red	x_R	$\theta = 0^\circ$	0.521	0.561	0.601		Note 5
		y_R		0.282	0.322	0.362		
	Green	x_G		0.317	0.357	0.397		
		y_G		0.516	0.556	0.596		
	Blue	x_B		0.117	0.157	0.197		
		y_B		0.093	0.133	0.173		
Color Reproduction				-	40	-	%	
Response Time		$T_r + T_d$	Ta= 25° C $\theta = 0^\circ$	-	36	-	ms	Note 6
Cross Talk		CT	$\theta = 0^\circ$	-	-	2.0	%	Note 7

SPEC. NUMBER
S864-1380

SPEC. TITLE
HX104X01-210 Product Specification

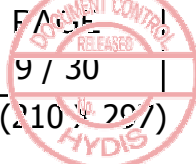

B2005-C001-C(3/3)

A4(210 x 297)



PRODUCT GROUP

REV

ISSUE DATE

TFT-LCD PRODUCT

0

2009.04.01

Note : 1. Viewing angle is the angle at which the contrast ratio is greater than 10. The viewing are determined for the horizontal or 3, 9 o'clock direction and the vertical or 6, 12 o'clock direction with respect to the optical axis which is normal to the LCD surface . (see FIGURE 1)

2. Contrast measurements shall be made at viewing angle of Θ= 0° and at the center of the LCD surface. Luminance shall be measured with all pixels in the view field set first to white, then to the dark (black) state. (See FIGURE 1) Luminance Contrast Ratio (CR) is defined mathematically.

CR = Luminance when displaying a white raster / Luminance when displaying a black raster

3. Luminance of white is defined as a luminance value of a point across the LCD surface. Luminance shall be measured with all pixels in the view field set first to white. This measurement shall be taken at the locations shown in FIGURE 2 for a total of the measurements per display.

4. The White luminance uniformity on LCD surface is then expressed. (See FIGURE 2)

Uniformity ΔY = (Minimum Luminance of 5(or 13) points / Maximum Luminance of 5(or 13) points) X 100 (%)

5. The color chromaticity coordinates specified in Table 4 shall be calculated from the spectral data measured with all pixels first in red, green, blue and white. Measurements shall be made at the center of the panel.

6. The electro-optical response time measurements shall be made as FIGURE 3 by switching the data input signal OFF and ON. The times needed for the luminance to change from 10% to 90% is Tr, and 90% to 10% is Td.

7. Cross-Talk of one area of the LCD surface by another shall be measured by comparing the luminance (YA) of a 25mm diameter area, with all display pixels set to a gray level, to the luminance (YB) of that same area when any adjacent area is driven dark. (See FIGURE 4).

SPEC. NUMBER S864-1380

SPEC. TITLE HX104X01-210 Product Specification

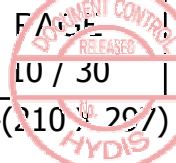



PRODUCT GROUP

REV

ISSUE DATE

TFT-LCD PRODUCT

0

2009.04.01

5.0 INTERFACE CONNECTION.

5.1 Electrical Interface Connection

CN1 : Interface Connector : FI-XB30S-HF10 (JAE) or equivalent

User side Connector : FI-X30S (JAE) or equivalent

Pin No	Symbol	Function	Remark
1	VSS	Ground	
2	VDD1	Power Supply: +3.3V	
3	VDD2	Power Supply: +3.3V	
4	EDID 3.3V	EDID +3.3V	
5	NC	Reserved	
6	EDID CLK	EDID CLK	
7	EDID DATA	EDID DATA	
8	RIN0-	LVDS Negative data signal (-)	Tx pin # 48
9	RIN0+	LVDS Positive data signal (+)	Tx pin # 47
10	VSS	Ground	
11	RIN1-	LVDS Negative data signal (-)	Tx pin # 46
12	RIN1+	LVDS Positive data signal (+)	Tx pin # 45
13	VSS	Ground	
14	RIN2-	LVDS Negative data signal (-)	Tx pin # 42
15	RIN2+	LVDS Positive data signal (+)	Tx pin # 41
16	VSS	Ground	
17	RCLKIN-	LVDS Negative clock signal (-)	Tx pin # 40
18	RCLKIN+	LVDS Positive clock signal (+)	Tx pin # 39
19	VSS	Ground	
20	VDIM	PWM Brightness Control	
21	VSW	LED On/Off Control	
22	VSS	Ground	
23	VSS	Ground	
24	VSS	Ground	
25	VSS	Ground	
26	VCD1	Back-light Power Supply: +12V	HVDD: 7~20V
27	VCD2	Back-light Power Supply: +12V	
28	VCD3	Back-light Power Supply: +12V	
29	VCD4	Back-light Power Supply: +12V	
30	VSS	Ground	

SPEC. NUMBER
S864-1380

SPEC. TITLE
HX104X01-210 Product Specification

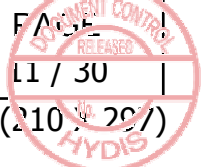

B2005-C001-C(3/3)

A4(210 / 297)

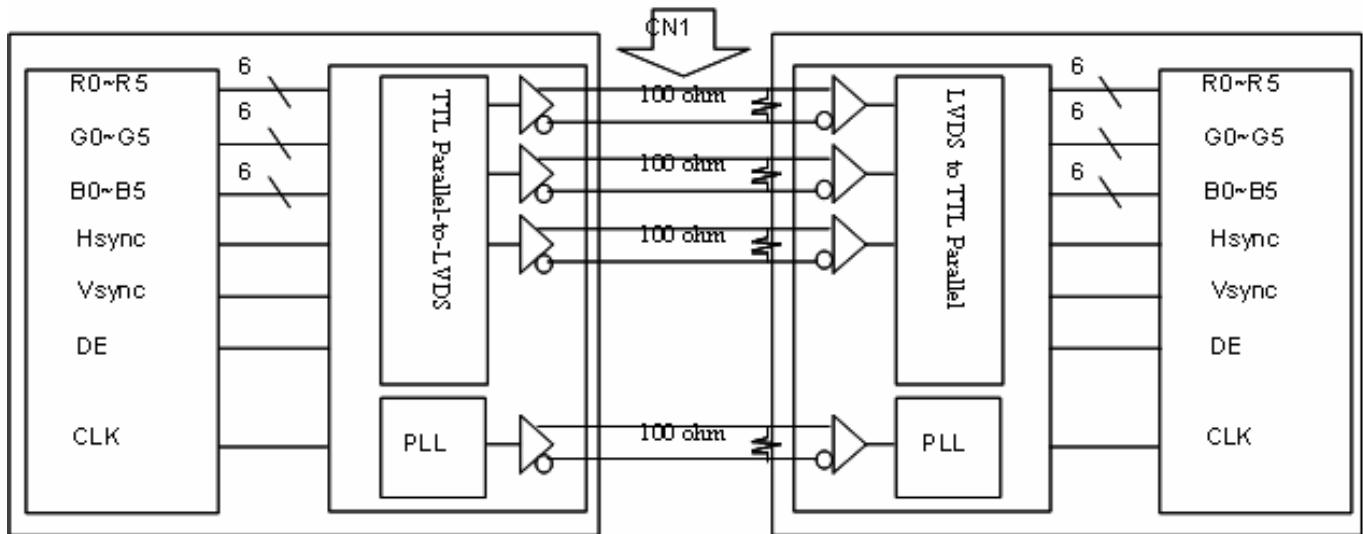
[LVDS Block Diagram]

5.1.1 INTERFACE CONNECTION

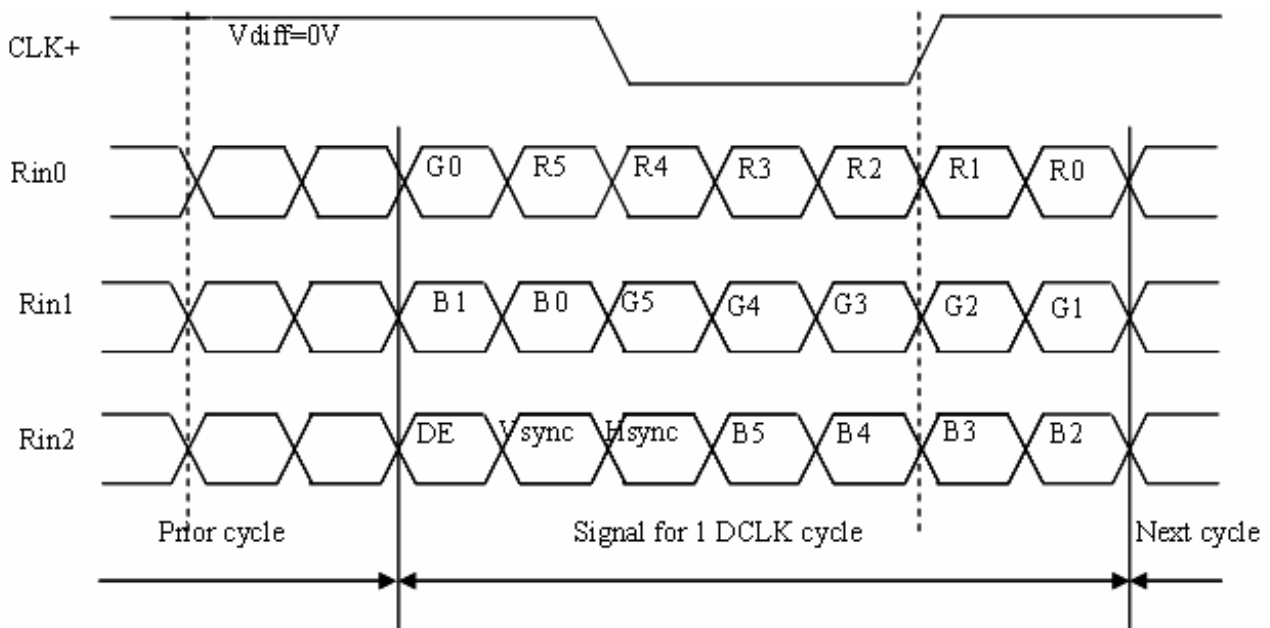



PRODUCT GROUP

REV

ISSUE DATE

TFT-LCD PRODUCT

0

2009.04.01

5.2. LVDS Interface

LVDS Transmitter: THC63LVDM83A or equivalent.

INPUT SIGNAL	TRANSMITTER		INTERFACE		FI-XB30S-HF10	REMARK
	PIN NO.	PIN NO.	SYSTEM (TX)	TFT-LCD (RX)	PIN NO.	
R0	51	48 47	OUT0- OUT0+	IN0- IN0+	8 9	
R1	52					
R2	54					
R3	55					
R4	56					
R5	3					
G0	4	46 45	OUT1- OUT1+	IN1- IN1+	11 12	
G1	6					
G2	7					
G3	11					
G4	12					
G5	14					
B0	15	42 41	OUT2- OUT2+	IN2- IN2+	14 15	
B1	19					
B2	20					
B3	22					
B4	23					
B5	24					
HSYNC	27	40	CLKOUT-	CLKIN-	17	
VSYNC	28					
DE	30	39	CLKOUT+	CLKIN+	18	
MCLK	31					

SPEC. NUMBER
S864-1380

SPEC. TITLE
HX104X01-210 Product Specification

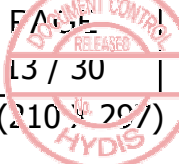

5.3 Back-light Interface

CN2 LED FPC Connector (20397-008E, Manufactured by I-PEX)

Pin No.	Symbol	Function	Remark
1	Anode1	LED Anode Power Supply	LED Anode Power Supply (3.2V X 7 EA = 22.4V)
2	NC	Non-Connection	
3	Cathode1	LED Cathode Power Supply	LED Cathode Power Supply
4	Cathode2	LED Cathode Power Supply	
5	Cathode3	LED Cathode Power Supply	
6	Cathode4	LED Cathode Power Supply	
7	Cathode5	LED Cathode Power Supply	
8	Cathode6	LED Cathode Power Supply	

5.4. Data Input Format

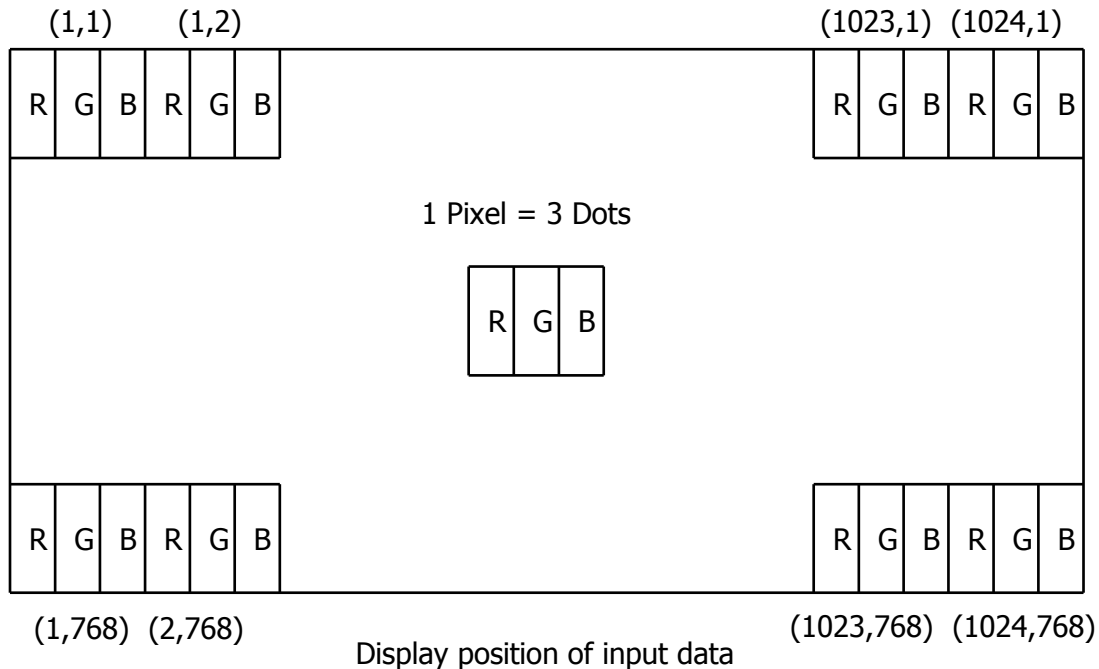
SPEC. NUMBER
S864-1380

SPEC. TITLE
HX104X01-210 Product Specification

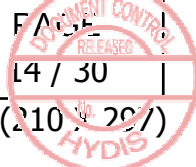

6.0. SIGNAL TIMING SPECIFICATIONS

6.1 LVDS Transmitter Input

The 10.4" XGA LCM is operated by the only DE (Data enable) mode (LVDS Transmitter Input)

ITEM	SYMBOL	MIN	TYP	MAX	UNIT
Frame Period	T1	772	806	-	lines
Vertical Display Period	T2	-	768	-	lines
One Line Scanning Period	T3	1100	1344	-	clocks
Horizontal Display Period	T4	-	1024	-	clocks
Clock Frequency	1/T5	-	65	80	MHz

6.2. LVDS Rx interface timing parameter

ITEM	SYMBOL	MIN	TYP	MAX	UNIT	REMARK
CLKIN Period	tRCIP	12.5	15.38	-	nsec	
Input Data 0	tRIP1	-0.4	0.0	+0.4	nsec	
Input Data 1	tRIP0	tRCIP/7-0.4	tRCIP/7	tRCIP/7+0.4	nsec	
Input Data 2	tRIP6	2 × tRCIP/7-0.4	2 × tRCIP/7	2 × tRCIP/7+0.4	nsec	
Input Data 3	tRIP5	3 × tRCIP/7-0.4	3 × tRCIP/7	3 × tRCIP/7+0.4	nsec	
Input Data 4	tRIP4	4 × tRCIP/7-0.4	4 × tRCIP/7	4 × tRCIP/7+0.4	nsec	
Input Data 5	tRIP3	5 × tRCIP/7-0.4	5 × tRCIP/7	5 × tRCIP/7+0.4	nsec	
Input Data 6	tRIP2	6 × tRCIP/7-0.4	6 × tRCIP/7	6 × tRCIP/7+0.4	nsec	

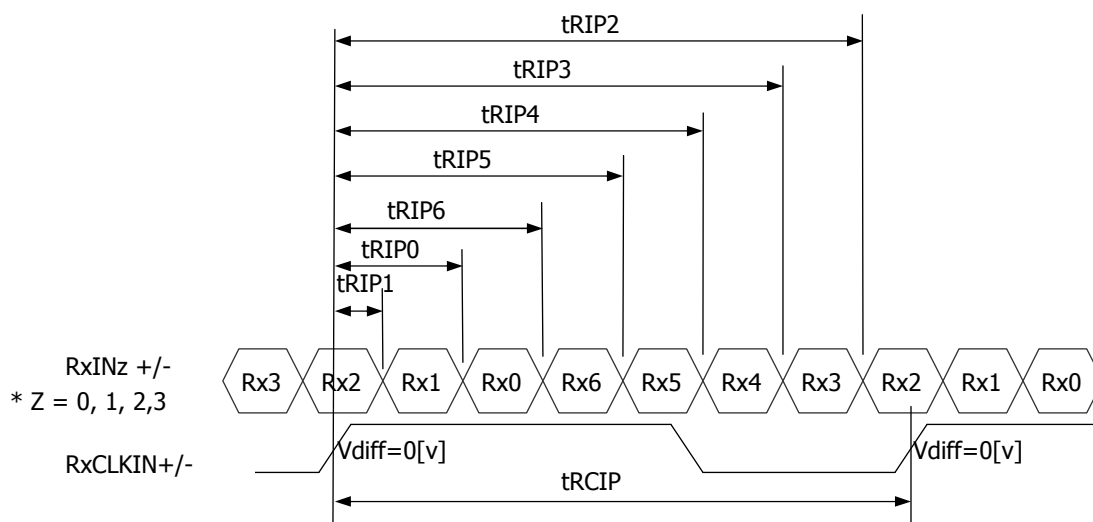

SPEC. NUMBER
S864-1380

SPEC. TITLE
HX104X01-210 Product Specification

FACE
RELEASED
15 / 30
A4(210 x 297)
HYDIS

7.0 SIGNAL TIMING WAVEFORMS OF INTERFACE SIGNAL (DE MODE)

7.1 Timing Waveforms of Interface Signal

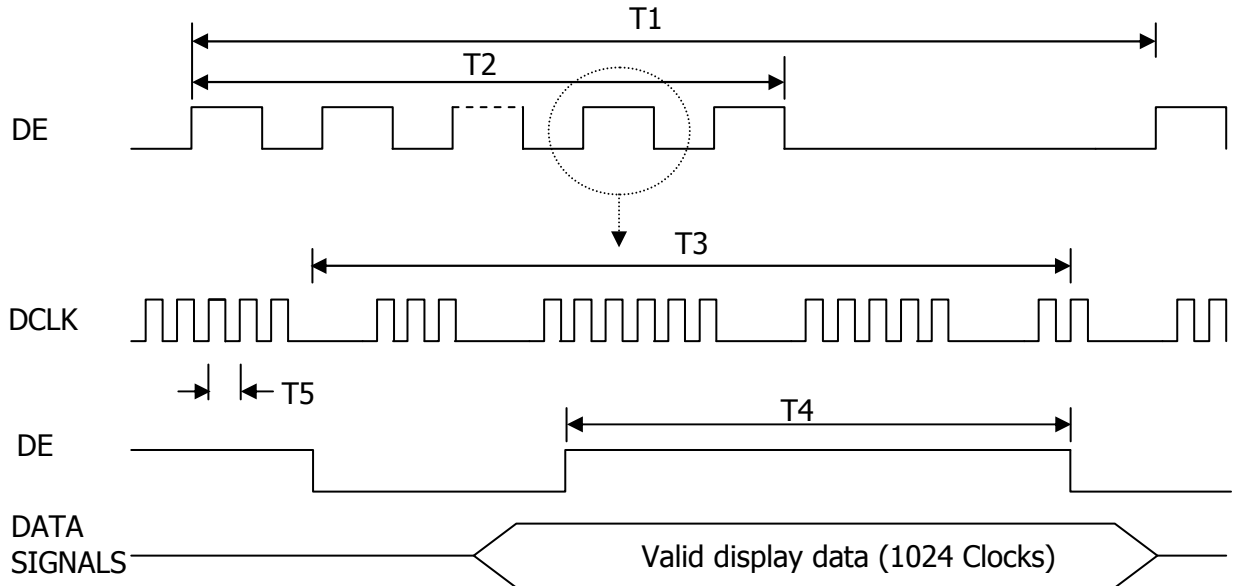



PRODUCT GROUP

REV

ISSUE DATE

TFT-LCD PRODUCT

0

2009.04.01

8.0 INPUT SIGNALS, BASIC DISPLAY COLORS & GRAY SCALE OF COLORS

Each color is displayed in sixty-four gray scales from a 6 bit data signal input. A total of 262,144 colors are derived from the resultant 18 bit data.

COLORS & GRAY SCALE	RED DATA						GREEN DATA						BLUE DATA						
	R5	R4	R3	R2	R1	R0	G5	G4	G3	G2	G1	G0	B5	B4	B3	B2	B1	B0	
Basic Colors	Black	0	0	0	0	0	0	0	0	0	0	0	0	0	0	0	0	0	
	Blue	0	0	0	0	0	0	0	0	0	0	0	1	1	1	1	1	1	
	Green	0	0	0	0	0	0	1	1	1	1	1	1	0	0	0	0	0	
	Cyan	0	0	0	0	0	0	1	1	1	1	1	1	1	1	1	1	1	
	Red	1	1	1	1	1	1	0	0	0	0	0	0	0	0	0	0	0	
	Magenta	1	1	1	1	1	1	0	0	0	0	0	0	1	1	1	1	1	
	Yellow	1	1	1	1	1	1	1	1	1	1	1	1	0	0	0	0	0	
	White	1	1	1	1	1	1	1	1	1	1	1	1	1	1	1	1	1	
Gray Scale Of Red	Black	0	0	0	0	0	0	0	0	0	0	0	0	0	0	0	0	0	
	△	0	0	0	0	0	1	0	0	0	0	0	0	0	0	0	0	0	
	Darker	0	0	0	0	1	0	0	0	0	0	0	0	0	0	0	0	0	
	△	↓						↓						↓					
	▽	↓						↓						↓					
	Brighter	1	1	1	1	0	1	0	0	0	0	0	0	0	0	0	0	0	
	▽	1	1	1	1	1	0	0	0	0	0	0	0	0	0	0	0	0	
	Red	1	1	1	1	1	1	0	0	0	0	0	0	0	0	0	0	0	
Gray Scale Of Green	Black	0	0	0	0	0	0	0	0	0	0	0	0	0	0	0	0	0	
	△	0	0	0	0	0	0	0	0	0	0	1	0	0	0	0	0	0	
	Darker	0	0	0	0	0	0	0	0	0	0	1	0	0	0	0	0	0	
	△	↓						↓						↓					
	▽	↓						↓						↓					
	Brighter	0	0	0	0	0	0	1	1	1	1	0	1	0	0	0	0	0	
	▽	0	0	0	0	0	0	1	1	1	1	1	0	0	0	0	0	0	
	Green	0	0	0	0	0	0	1	1	1	1	1	1	0	0	0	0	0	
Gray Scale Of Blue	Black	0	0	0	0	0	0	0	0	0	0	0	0	0	0	0	0	0	
	△	0	0	0	0	0	0	0	0	0	0	0	0	0	0	0	0	1	
	Darker	0	0	0	0	0	0	0	0	0	0	0	0	0	0	0	0	1	
	△	↓						↓						↓					
	▽	↓						↓						↓					
	Brighter	0	0	0	0	0	0	0	0	0	0	0	0	1	1	1	1	0	
	▽	0	0	0	0	0	0	0	0	0	0	0	0	1	1	1	1	0	
	Blue	0	0	0	0	0	0	0	0	0	0	0	0	1	1	1	1	1	
Gray Scale Of White & Black	Black	0	0	0	0	0	0	0	0	0	0	0	0	0	0	0	0	0	
	△	0	0	0	0	0	1	0	0	0	0	0	1	0	0	0	0	1	
	Darker	0	0	0	0	1	0	0	0	0	0	1	0	0	0	0	0	1	
	△	↓						↓						↓					
	▽	↓						↓						↓					
	Brighter	1	1	1	1	0	1	1	1	1	0	1	1	1	1	1	0	1	
	▽	1	1	1	1	1	0	1	1	1	1	1	0	1	1	1	1	0	
	White	1	1	1	1	1	1	1	1	1	1	1	1	1	1	1	1	1	

SPEC. NUMBER
S864-1380

SPEC. TITLE
HX104X01-210 Product Specification

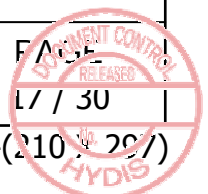

B2005-C001-C(3/3)

A4(210 x 297)

9.0 POWER SEQUENCE

To prevent a latch-up or DC operation of the LCD module, the power on/off sequence shall be as shown in below

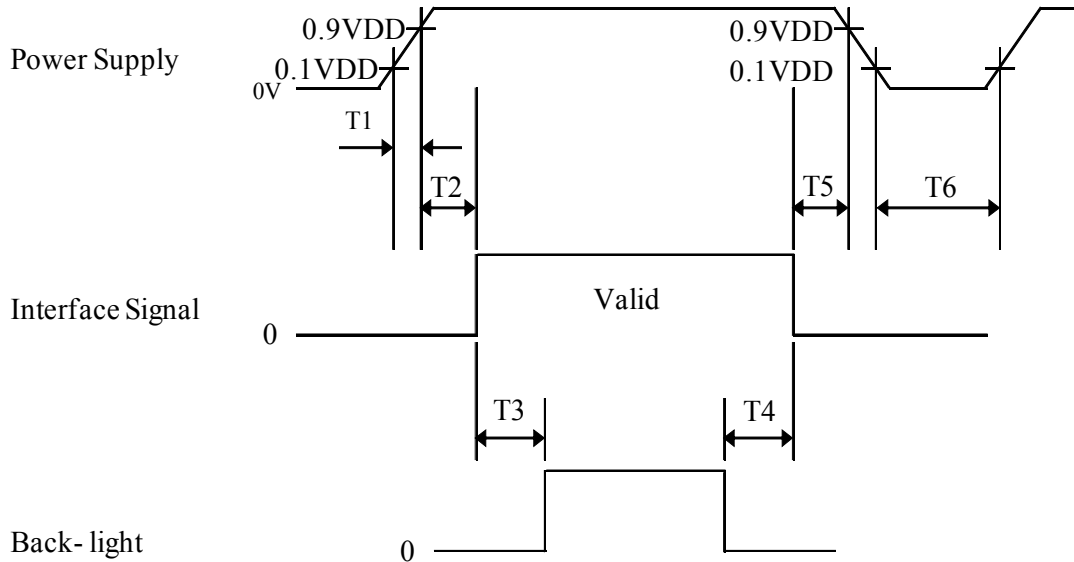

Parameter	Values			Units
	Min	Typ	Max	
T1	0	-	10	ms
T2	0	-	50	ms
T3	100	-	-	ms
T4	100	-	-	ms
T5	0	-	50	ms
T6	1	-	-	Sec

Notes:

1. When the power supply VDD is 0V, Keep the level of input signals on the low or keep high impedance.
2. Do not keep the interface signal high impedance when power is on.
3. Back Light must be turn on after power for logic and interface signal are valid.

10.0 MECHANICAL CHARACTERISTICS

10.1 Dimensional Requirements

FIGURE 5, 6 shown in appendix shows mechanical outlines for the model.

PARAMETER	SPECIFICATION	UNIT
Active area	210.432 (H) × 157.824 (V)	mm
Number of pixels	1024 (H) × 768 (V) (1 pixel = R + G + B dots)	pixels
Pixel pitch	0.2055 (H) × 0.2055 (V)	mm
Pixel arrangement	RGB Vertical stripe	
Display colors	262,144	colors
Display mode	Normally Black	
Dimensional outline	238.6 ± 0.5 (W) X 173.2 ± 0.5 (V) X 4.3 Max. (LED), 6.8 Max. (Component)	mm
Weight	210 Typ. / 220 Max.	g
Back-light	SMD LED Array	

10.2 Mounting

See FIGURE 5. (shown in Appendix)

10.3 Anti-Glare Polarizer.

The surface of the LCD has an anti-glare coating to minimize reflection and a coating to reduce scratching.

10.4 Light Leakage

There shall not be visible light from the back-lighting system around the edges of the screen as seen from a distance 50 cm from the screen with an overhead light level of 150lux. The manufacture shall furnish limit samples of the panel showing the light leakage acceptable.

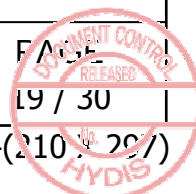

**HYDIS****PRODUCT GROUP**

REV

ISSUE DATE

TFT-LCD PRODUCT

0

2009.04.01

11.0 RELIABILITY TEST

NO	TEST ITEMS	CONDITIONS
1	High temperature storage test	Ta = 80 °C, 240 hrs
2	Low temperature storage test	Ta = -20 °C, 240 hrs
3	High temperature & high humidity operation test	Ta = 50 °C, 80%RH, 240hrs
4	High temperature operation test	Ta = 70 °C, 240 hrs
5	Low temperature operation test	Ta = 0 °C, 240 hrs
6	Thermal shock	Ta = -20 °C ~ 80 °C (0.5H), 100 cycle
7	Vibration test (non-operating)	Frequency : 10~500Hz Gravity/AMP : 1.5G Period : X,Y,Z 30min
8	Shock test (non-operating)	Gravity : 220G Pulse width : 2ms, half sine wave ±X, ±Y, ±Z Once for each direction
9	Electro-Static Discharge Test (non-operating)	Air : 150pF, 330ohm, 15KV Contact : 150pF, 330ohm, 8KV

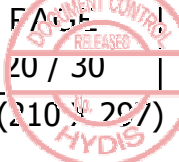
SPEC. NUMBER
S864-1380SPEC. TITLE
HX104X01-210 Product Specification

B2005-C001-C(3/3)

A4(210 / 297)

12.0 PACKING SPECIFICATION

12.1 Packing Order

Hydis provides the standard shipping container for customers, unless customer specifies their packing information. The standard packing method is shown in below.

Put Pad into the box.



Put silica gels in the box.

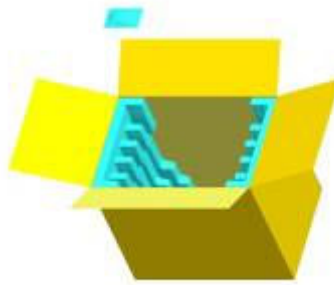

After sealing the box, attach Packing Label on the attach position sign area of the box.



Place a cover on the top of the box.

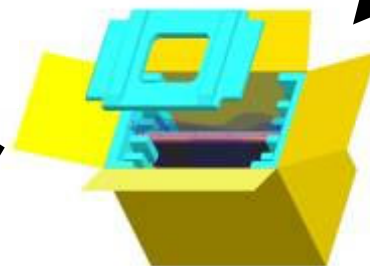

As shown in the figure, place the Modules bundled by shielding bag in the box.

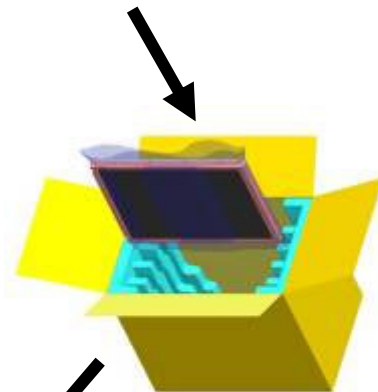

Notes

- Box Dimension: 349.0mm(W) X 261.0mm(D) X 311.0mm(H)
- Package Quantity in one Box: 10pcs

SPEC. NUMBER
S864-1380

SPEC. TITLE
HX104X01-210 Product Specification

FACE
21 / 30

B2005-C001-C(3/3)

A4(210 X 297)
HYDIS



HYDIS

PRODUCT GROUP

REV

ISSUE DATE

TFT-LCD PRODUCT

0

2009.04.01

12.2 Packing Label

Label Size: 108 mm (L) × 56 mm (W)

Contents

Model: HX104X01-210

Q`ty: Module Q`ty in one box

Serial No.: Box Serial No. See next figure for detail description.

Date: Packing Date

FG Code: FG Code of Product

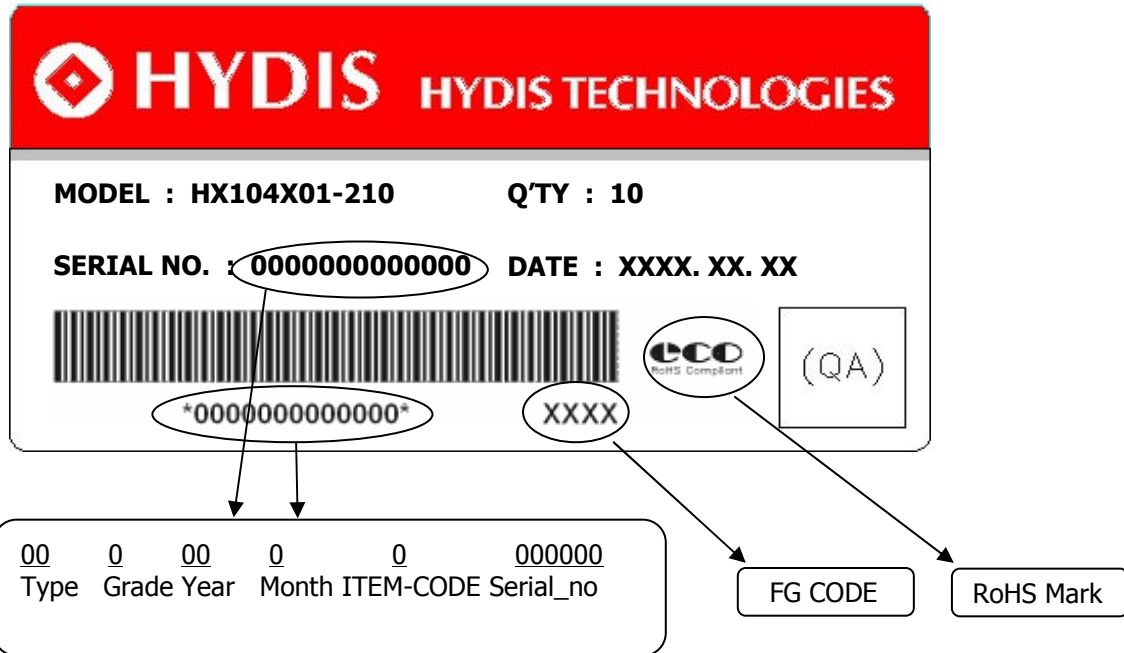

SPEC. NUMBER
S864-1380

SPEC. TITLE
HX104X01-210 Product Specification

Page
22 / 30





PRODUCT GROUP

REV

ISSUE DATE

TFT-LCD PRODUCT

0

2009.04.01

12.3 Product Label



HYDIS Barcode

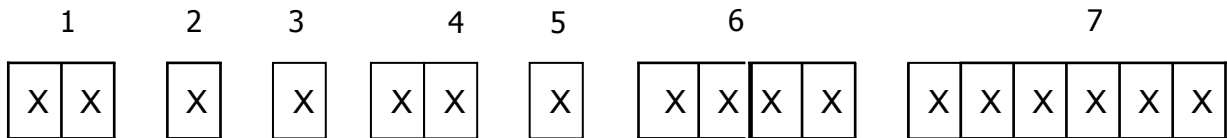

No 1. Control Number

No 2. Rank / Grade

No 3. Line Classification (HYDIS : H)

No 4. Year (5 : 2005, 6 : 2006, ...)

No 5. Month (1, 2, 3, ..., 9, X, Y, Z)

No 6. FG Code

No 7. Serial Number

SPEC. NUMBER
S864-1380

SPEC. TITLE
HX104X01-210 Product Specification

PAGE
23 / 30





HYDIS

PRODUCT GROUP

REV

ISSUE DATE

TFT-LCD PRODUCT

0

2009.04.01

13.0 HANDLING & CAUTIONS

13.1 Cautions when taking out the module

- Pick the pouch only, when taking out module from a shipping package.

13.2 Cautions for handling the module

- As the electrostatic discharges may break the LCD module, handle the LCD module with care. Peel a protection sheet off from the LCD panel surface as slowly as possible.
- As the LCD panel and backlight element are made from fragile glass material, impulse and pressure to the LCD module should be avoided.
- As the surface of the polarizer is very soft and easily scratched, use a soft dry cloth without chemicals for cleaning.
- Do not pull the interface connector in or out while the LCD module is operating.
- Put the module display side down on a flat horizontal plane.
- Handle connectors and cables with care.

13.3 Cautions for the operation

- When the module is operating, do not lose MCLK, DE signals. If any one of these signals were lost, the LCD panel would be damaged.
- Obey the supply voltage sequence. If wrong sequence were applied, the module would be damaged.

13.4 Cautions for the atmosphere

- Dewdrop atmosphere should be avoided.
- Do not store and/or operate the LCD module in a high temperature and/or humidity atmosphere. Storage in an electro-conductive polymer-packing pouch and under relatively low temperature atmosphere is recommended.

13.5 Cautions for the module characteristics

- Do not apply fixed pattern data signal to the LCD module at product aging.
- Applying fixed pattern for a long time may cause image sticking.

13.6 Other cautions

- Do not disassemble and/or re-assemble LCD module.
- Do not re-adjust variable resistor or switch etc.
- When returning the module for repair or etc, please pack the module not to be broken.
We recommend using the original shipping packages.

SPEC. NUMBER
S864-1380

SPEC. TITLE
HX104X01-210 Product Specification

FACE
24 / 30

A4(210 x 297)

HYDIS



PRODUCT GROUP

REV

ISSUE DATE

TFT-LCD PRODUCT

0

2009.04.01

14.0 EDID Data

Add	Function	Hex	Input Value	Add	Function	Hex	Input Value
00	Header	00	EDID	20	Blue y high bits	21	
01		FF		21	White x high bits	50	0.313
02		FF		22	White y high bits	54	0.329
03		FF		23	Established timing 1	21	
04		FF		24	Established timing 2	08	
05		FF		25	Established timing 3	00	
06		FF		26	Standard timing #1	01	Not Used
07		00		27		01	
08	ID Manufacturer Name	09	ID	28	Standard timing #2	01	Not Used
09		E5		29		01	
0A	ID Product Code	00	10.4XGA	2A	Standard timing #3	01	Not Used
0B		40		2B		01	
0C	32-bit serial No.	00		2C	Standard timing #4	01	Not Used
0D		00		2D		01	
0E		00		2E	Standard timing #5	01	Not Used
0F		00		2F		01	
10	Week of manufacture	00	0	30	Standard timing #6	01	Not Used
11	Year of Manufacture	13	2009	31		01	
12	EDID Structure Ver.	01	1	32	Standard timing #7	01	Not Used
13	EDID revision #	03	3	33		01	
14	Video input definition	80		34	Standard timing #8	01	Not Used
15	Max H image size	15	21	35		01	
16	Max V image size	10	16	36	Detailed timing / monitor descriptor #1	64	. Main clock : 65.0MHz . Hor. Active : 1024 . Hor. Blanking : 320 . 4 bits of Hor. Active + 4 bits of Hor. Blanking . Ver. Active : 768 . Ver. Blanking : 38 . 4 bits of Ver. Active + 4 bits of Ver. Blanking . Hor. Sync Offset : 24 . H sync Pulse Width:136 . V sync Offset : 1 line . V Sync Pulse width : 3 line
17	Display Gamma	78	2.2	37		19	
18	Feature support	EA	RGB mode	38		00	
19	Red/Green low bits	BD		39		40	
1A	Blue/White low bits	30		3A		41	
1B	Red x high bits	91		3B		00	
1C	Red y high bits	54		3C		26	
1D	Green x high bits	4F		3D		30	
1E	Green y high bits	8B		3E		18	
1F	Blue x high bits	26		3F		88	

SPEC. NUMBER
S864-1380

SPEC. TITLE
HX104X01-210 Product Specification

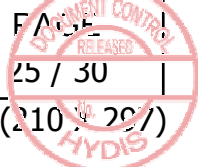

B2005-C001-C(3/3)

A4(210 x 297)



PRODUCT GROUP

REV

ISSUE DATE

TFT-LCD PRODUCT

0

2009.04.01

Add	Function	Hex	Input Value	Add	Function	Hex	Input Value		
40	Detailed timing / monitor descriptor #1	36	. Horizontal Image Size : 210 mm (Low 8 bits) . Vertical Image Size : 158 mm (Low 8 bits) . 4 bits of Hor. Image Size + 4 bits of Ver. Image Size . Hor. Border : 0 pixel . Vertical Border : 0 line	60	Detailed timing / monitor descriptor #3	59	Company name : HYDIS		
41		00		61		44			
42		D2		62		49			
43		9E		63		53			
44		00		64		0A			
45		00		65		20			
46		00		66		20			
47		18		67		20			
48	Detailed timing / monitor descriptor #2	28		68	Detailed timing / monitor descriptor #4	20	Model name : HX104X01-210		
49		15		69		20			
4A		00		6A		20			
4B		40		6B		20			
4C		41		6C		00			
4D		00		6D		00			
4E		26		6E		00			
4F		30		6F		FE			
50		18		70		00			
51		88		71		48			
52		36		72		58			
53		00		73		31			
54		D2		74		30			
55		9E		75		34			
56		00		76		58			
57	00	77	30						
58	00	78	31						
59	18	79	2D						
5A	Detailed timing / monitor descriptor #3	00		7A	Extension flag	32			
5B		00		7B		31			
5C		00		7C		30			
5D		FE		7D		0A			
5E		00		7E		00			
5F		48		7F		Checksum		A7	

SPEC. NUMBER
S864-1380

SPEC. TITLE
HX104X01-210 Product Specification

FACE
26 / 30

B2005-C001-C(3/3)

A4(210 x 297)

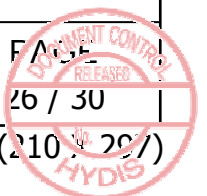

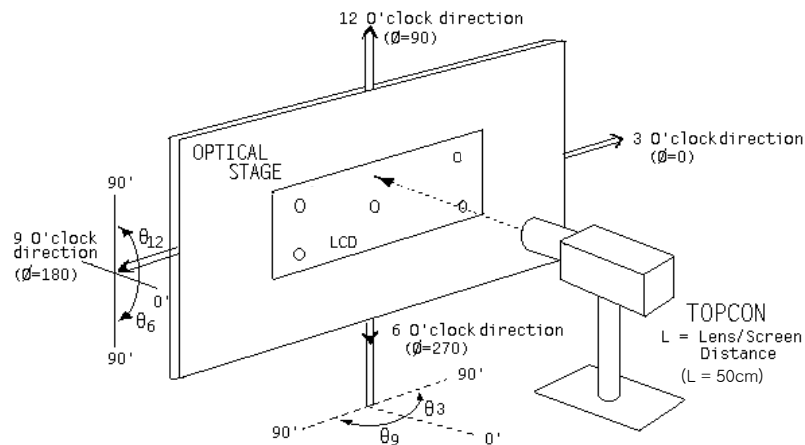
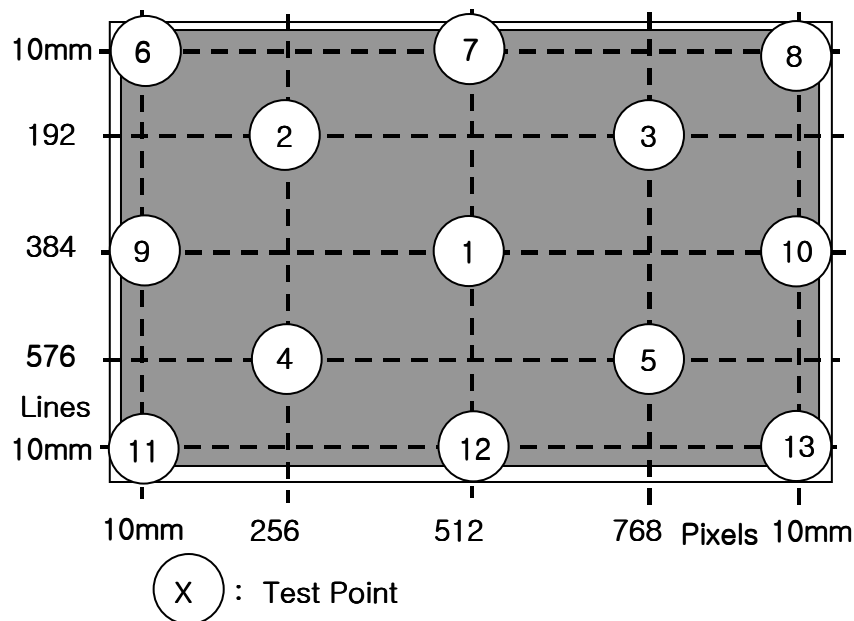
15.0 APPENDIX
Figure 1. Measurement Set Up

<Indoor>
Figure 2. Average Luminance Measurement Locations & Uniformity Measurement Locations

SPEC. NUMBER
S864-1380

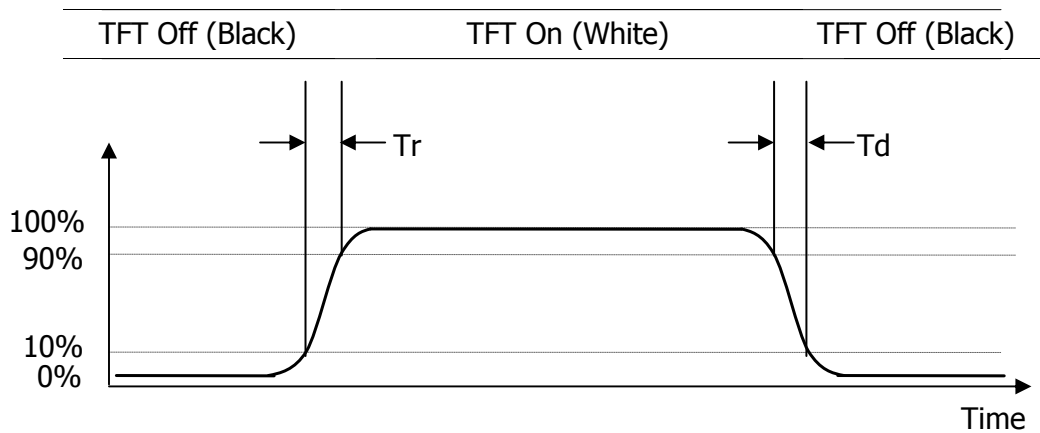
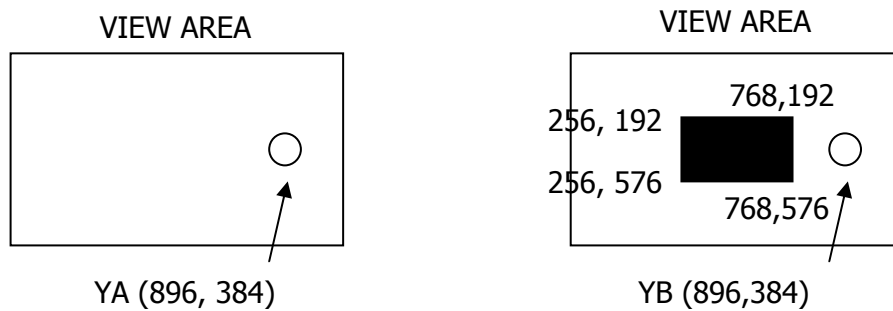
SPEC. TITLE
HX104X01-210 Product Specification

FACE
27 / 30
HYDIS

Figure 3. Response Time Testing

Figure 4. Cross Modulation Test Description

$$\text{Cross-Talk} = \frac{Y_B - Y_A}{Y_A} \times 100$$

Where:

 Y_A = Initial luminance of measured area (cd/m²)

 Y_B = Subsequent luminance of measured area (cd/m²)

The location measured will be exactly the same in both patterns.

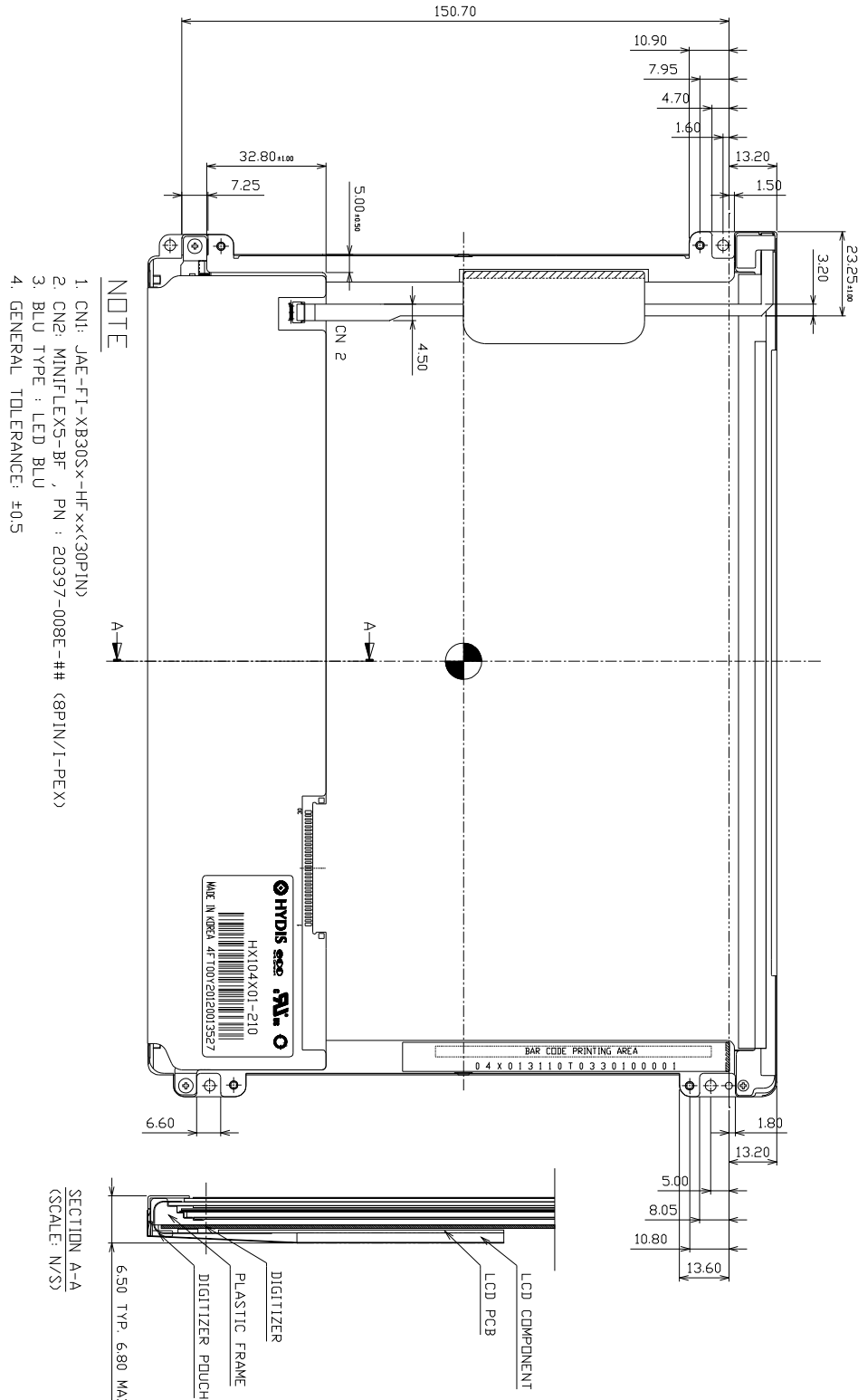
Figure 5. TFT-LCD Module Outline Dimensions (Rear View)

- NOTE**
1. CN1: JAE-FI-XB30SX-HFxx(30PIN)
 2. CN2: MINIFLEX5-BF, PN: E0397-008E-## (8PIN/I-PEX)
 3. BLU TYPE: LED BLU
 4. GENERAL TOLERANCE: ±0.5

SPEC. NUMBER
S864-1380
SPEC. TITLE
HX104X01-210 Product Specification

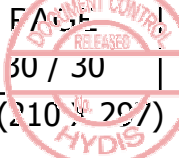

 PAGE 30 / 30
 A4(210 x 297)