

mass integrated

global part distribution • product lifecycle partner
excess inventory management • value-ad service provider



Data sheet provided by Mass Integrated

massintegrated.com • displayalliance.com

Please call +1.978.465.6190
Email: sales@massintegrated.com



ISO 9001: 2008

Mass Integrated complies with all DMCA takedown notices. Please send a formal DMCA Takedown Notice to Mass Integrated Systems, Inc. • 18 Henry Graf Jr. Road, Unit 1 • Newburyport, MA 01950.

Product Specification

SPECIFICATION FOR APPROVAL

- () Preliminary Specification
(◆) Final Specification

Title	26" WXGA TFT LCD
-------	-------------------------

BUYER	General
MODEL	

SUPPLIER	LG.Philips LCD CO., Ltd.
*MODEL	LC260WX2
SUFFIX	SLE3

*When you obtain standard approval,
please use the above model name without suffix

APPROVED BY	SIGNATURE DATE
/	_____
/	_____
/	_____

Please return 1 copy for your confirmation with your signature and comments.

APPROVED BY	SIGNATURE DATE
<u>J.H.Lee / Senior Manager</u>	_____
REVIEWED BY	
<u>H.I.Jang / Manager</u>	_____
PREPARED BY	
<u>H.G.Kang / Engineer</u>	_____

**TV Products Engineering Dept.
LG. Philips LCD Co., Ltd**

Product Specification

CONTENTS

NO.	ITEM	Page
-	COVER	1
-	CONTENTS	2
-	RECORD OF REVISIONS	3
1	GENERAL DESCRIPTION	4
2	ABSOLUTE MAXIMUM RATINGS	5
3	ELECTRICAL SPECIFICATIONS	6
1	ELECTRICAL CHARACTREISTICS	6
2	INTERFACE CONNECTIONS	8
3	SIGNAL TIMING SPECIFICATIONS	12
4	SIGNAL TIMING WAVEFORMS	13
5	COLOR INPUT DATA REFERNECE	14
6	POWER SEQUENCE	15
4	OPTICAL SFECIFICATIONS	17
5	MECHANICAL CHARACTERISTICS	21
6	RELIABLITY	24
7	INTERNATIONAL STANDARDS	25
1	SAFETY	
2	EMC	
8	PACKING	26
1	DESIGNATION OF LOT MARK	
2	PACKING FORM	
9	PRECAUTIONS	27

Product Specification

1. General Description

The LC260WX2 is a Color Active Matrix Liquid Crystal Display with an integral External Electrode Fluorescent Lamp(EEFL) backlight system. The matrix employs a-Si Thin Film Transistor as the active element. It is a transmissive type display operating in the normally black mode. This TFT-LCD has a 26.0 inch diagonally measured active display area with WXGA resolution (768 vertical by 1366 horizontal pixel array). Each pixel is divided into Red, Green and Blue sub-pixels or dots which are arranged in vertical stripes. Gray scale or the luminance of the sub-pixel color is determined with a 8-bit gray scale signal for each dot, thus, presenting a palette of more than 16,7M(True) colors. The LC260WX2 has been designed to apply the LVDS interface. It is intended to support LCD TV, PC TV where high brightness, super wide viewing angle, high color gamut, high color depth, and fast response time are important.

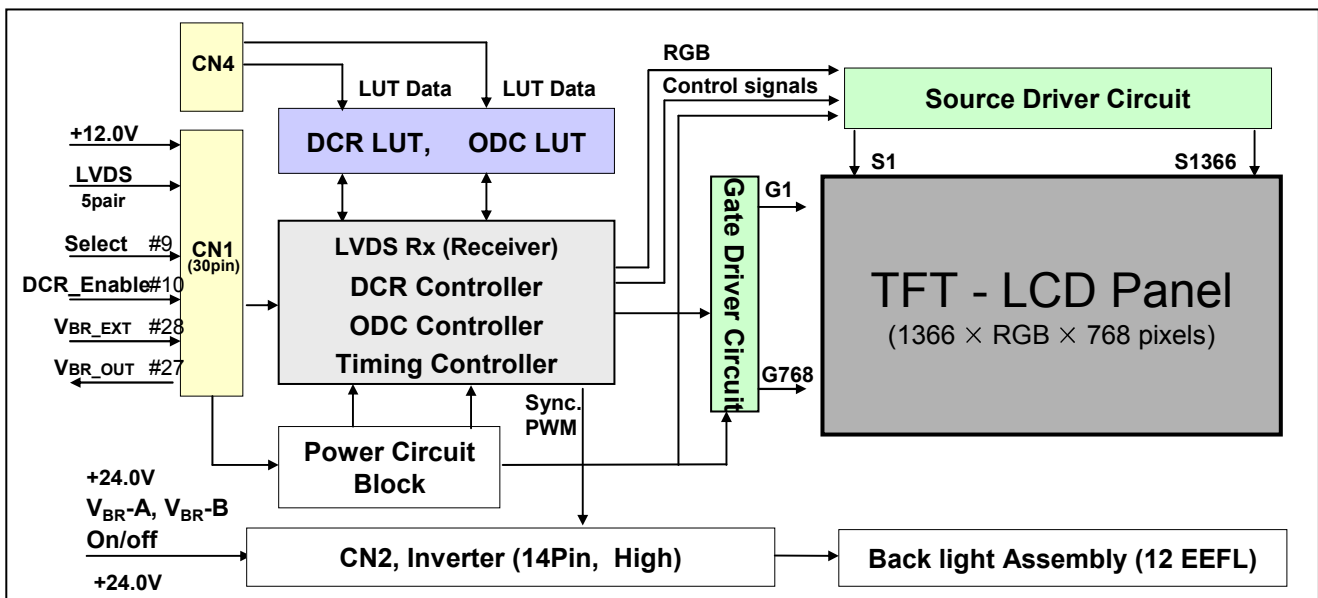

Figure 1. Block diagram

General Features

Active screen size	26.005 inches(660.53mm) diagonal
Outline Dimension	626(H) x 373(V) x 47.1(D) mm(Typ.)
Pixel Pitch	140.5 um x 421.5 um x RGB
Pixel Format	1366 horizontal by 768 vertical pixels. RGB stripe arrangement
Interface	LVDS 1port
Color depth	8-bit, 16,777,216 colors
Luminance, white	450 cd/m ² (Center 1 point, Typ.)
Viewing Angle (CR>10)	Viewing Angle Free(R/L 178(Typ.), U/D 178(Typ.))
Power Consumption	3.37W(logic), 75W(Backlight [VBR-A=1.65V])
Weight	4,300g(Typ.)
Display operating mode	Transmissive mode, normally black
Surface treatments	Hard coating (3H), Anti-glare treatment of the front polarizer

Product Specification

2. Absolute Maximum Ratings

Table 1. Absolute Maximum Ratings

Parameter	Symbol	Value		Unit	Note
		Min	Max		
Power Supply	V _{LCD}	-0.3	+14	V _{dc}	At 25°C
Input Voltage	V _{BL}	-0.3	+27	V _{dc}	
On/Off Control Voltage	V _{ON/OFF}	-0.3	+5.5	V _{dc}	
Brightness Control Voltage	V _{BR-A}	0	+5.0	V _{dc}	
Operating Temperature (Ambient Temp.)	T _{OP}	0	+50	°C	1
	T _{SUR}	0	+65	°C	2
Storage Temperature	T _{ST}	-20	+65	°C	1
Operating Ambient Humidity	H _{OP}	10	90	%RH	1
Storage Humidity	H _{ST}	10	90	%RH	1

Notes :

1. Temperature and relative humidity range are shown in the figure below.
Wet bulb temperature should be 39 °C Max, and no condensation.
2. Abnormal visual problems by panel front side surface temperature can be occurred in specific range (60 °C ~ 65 °C), But materials(ex : polarizer) are not damaged permanently in this range, T_{SUR}.
3. Ambient illuminance should be more than 10 lux.

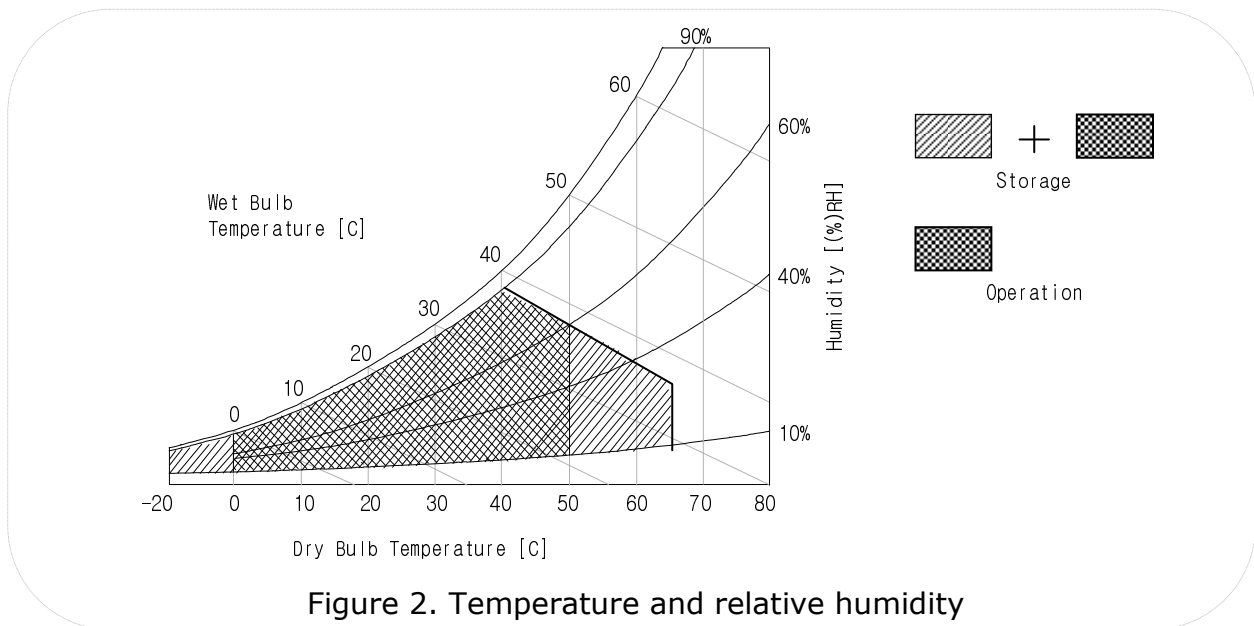

Product Specification

3. Electrical Specifications

The LC260WX2 requires two power inputs. One is employed to power the LCD electronics and to drive the TFT array and liquid crystal. The second input power for the EEFL/Backlight, is to power the inverter.

3-1. Electrical Characteristics

Table 2. Electrical Characteristics

Parameter	Symbol	Value			Unit	Note
		Min	Typ	Max		
1. Power for Panel:						
Power Supply Input Voltage	V_{LCD}	11.4	12.0	12.6	Vdc	
Power Supply Input Current	I_{LCD}	-	281	365	mA	1
		-	339	440	mA	2
Power Consumption	P_{LCD}	-	3.37	4.38	Watt	1
Inrush Current (V_{LCD} Input)	I_{RUSH}	-	-	3	A	3

Notes:

1. The specified current and power consumption are under the $V_{LCD}=12V$, $25^{\circ}C$, fV (frame frequency)=60Hz condition. Typical supply current is measured at the condition of 8 X 6 Mosaic pattern(white & black) shown in the [Figure 3] is displayed.
2. The current is specified at the maximum current pattern.
3. The duration of rush current is about 2ms and rising time of power input is 1ms(min).

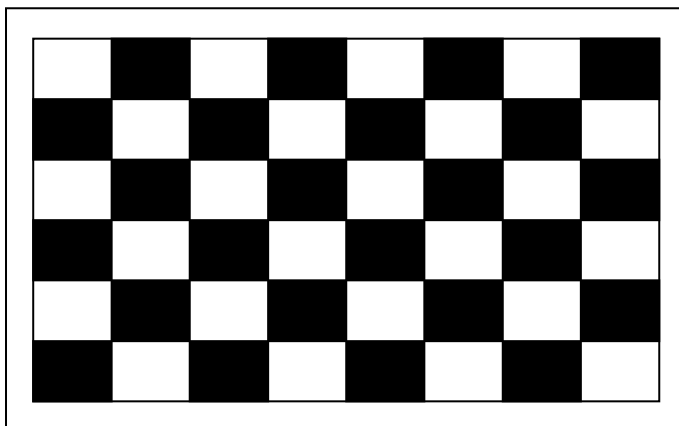

[Figure 3] Mosaic pattern

Product Specification
Table 3. ELECTRICAL CHARACTERISTICS (Continue)

Parameter	Symbol	Values			Unit	Notes		
		Min	Typ	Max				
Inverter :								
Power Supply Input Voltage	VBL	22.8	24.0	25.2	Vdc	1		
Power Supply Input Voltage Ripple		-	-	0.5	Vp-p	1		
Power Supply Input Current	After Aging	IBL_A	-	3.12	3.62	A	VBR_A = 1.65V ... 1	
			-	3.30	3.80	A	VBR_A = 3.3V ... 1	
	Before Aging	IBL_B	-	3.20	3.70	A	VBR_A = 1.65V ... 2	
			-	3.50	4.00	A	VBR_A t = 3.3V ... 2	
Power Supply Input Current(In-Rush)	Irush	-	-	6	A	VBL = 24V EXTVbr-B=100% VBR_A = 1.65V		
Power Consumption	PBL	-	75	86.88	W	1		
Input signal for Inverter control	Brightness Adjust	VBR_A	0.0	-	3.3	Vdc		
	On/Off	On	V on	2.8	-	5.0	Vdc	
		Off	V off	-0.3	0.0	0.8	Vdc	
	Brightness Adjust	EXTVBR-B	20		100	%	On duty	
PWM Frequency for NTSC & PAL	NTSC/PAL		180/150		Hz	3		
Pulse Duty Level(PWM) (Burst mode)	High Level	2.5	-	5.0	Vdc	HIGH: Lamp on LOW:Lamp off		
	Low Level	0.0	-	0.8	Vdc			
Lamp :								
Lamp Voltage (ExtVbr-B = 100%)	Vout	600	750	900	V(rms)	VBR_A = Typ		
Lamp Current (ExtVbr-B = 100%)	IO-MAX	80/84	90/94	100/104	mA(rms)	VBR_A = Max		
	IO-TYP	74/78	84/88	94/98	mA(rms)	VBR_A = TYP		
	IO-MIN	68/72	78/82	88/92	mA(rms)	VBR_A = Min		
Life Time	VBR-A(0V~3.3V)	50,000			Hrs	4		

Notes :

- Electrical characteristics are determined after the unit has been 'ON' and stable for approximately 120 minutes at $25 \pm 2^\circ\text{C}$. The specified current and power consumption are under the typical supply Input voltage 24V and Vbr 1.65V, it is total power consumption.
The ripple voltage of the power supply input voltage is under 0.5 Vp-p. LPL recommend Input Voltage is $24.0\text{V} \pm 5\%$.
- Electrical characteristics are determined within 30 minutes at $25 \pm 2^\circ\text{C}$.
The specified currents are under the typical supply Input voltage 24V.
- LPL recommend that the PWM freq. is synchronized with three times harmonic of Vsync signal of system.
- Specified Values are for a single lamp which is aligned horizontally.
The life time is determined as the time which luminance of the lamp is 50% compared to that of initial value at the typical/ maximum lamp current on condition of continuous operating at $25 \pm 2^\circ\text{C}$
- The duration of rush current is about 5ms.

Product Specification

3-2. Interface Connections

This LCD employs two kinds of interface connections. A 30 pin connector is used for LCD electronics and a 12pin connector is used for the integral backlight system.

3-2-1. Signal Interface

The LCD connector(CN1) : FI-X30SSL-HF (Manufactured by JAE) or Equivalent.

The pin configuration for the 30 pin connector is shown in the table below.

Table 4. 30Pin Connector pin configuration (For LCD Panel)

Pin	Signal assignment	Note	Pin	Signal assignment	Note
1	V _{LCD} (12V)		16	LVDS SIGNAL CHANNEL 1+	
2	V _{LCD} (12V)		17	GND	
3	V _{LCD} (12V)		18	LVDS SIGNAL CHANNEL 2-	
4	V _{LCD} (12V)		19	LVDS SIGNAL CHANNEL 2+	
5	GND		20	GND	
6	GND		21	LVDS CLOCK C-	
7	GND		22	LVDS CLOCK C+	
8	GND		23	GND	
9	Select	1	24	LVDS SIGNAL CHANNEL 3-	
10	GND		25	LVDS SIGNAL CHANNEL 3+	
11	GND		26	GND	
12	LVDS SIGNAL CHANNEL 0-		27	VBR_OUT(VBR output from LCD Module)	2
13	LVDS SIGNAL CHANNEL 0+		28	VBR_EXT (External VBR input from System to LCD Module)	2
14	GND		29	GND	
15	LVDS SIGNAL CHANNEL 1-		30	AGP	6



Rear view of LCM

- Part/No. : FI-X30SSL-HF(JAE) or equivalent
- Mating connector : FI-30C2L
(Manufactured by JAE) or compatible

Notes:

1. If pin9 is ground, interface format is "LG", and if pin9 is 3.3V, interface format is "DISM".
(See page 9~10)
2. If DCR function not use, this pins must be OPEN.
3. All GND(ground) pins should be connected together and should also be connected to the LCD's metal frame.
4. All power input pins should be connected together.
5. Input level of LVDS signal is based on the IEA664 standard.
6. If pin30 is 3.3V, no-signal is AGP pattern, and if pin30 is ground, no-signal is Black pattern

Product Specification

Table 5. Required signal assignment for LVDS transmitter (Pin9 = "L" or open)

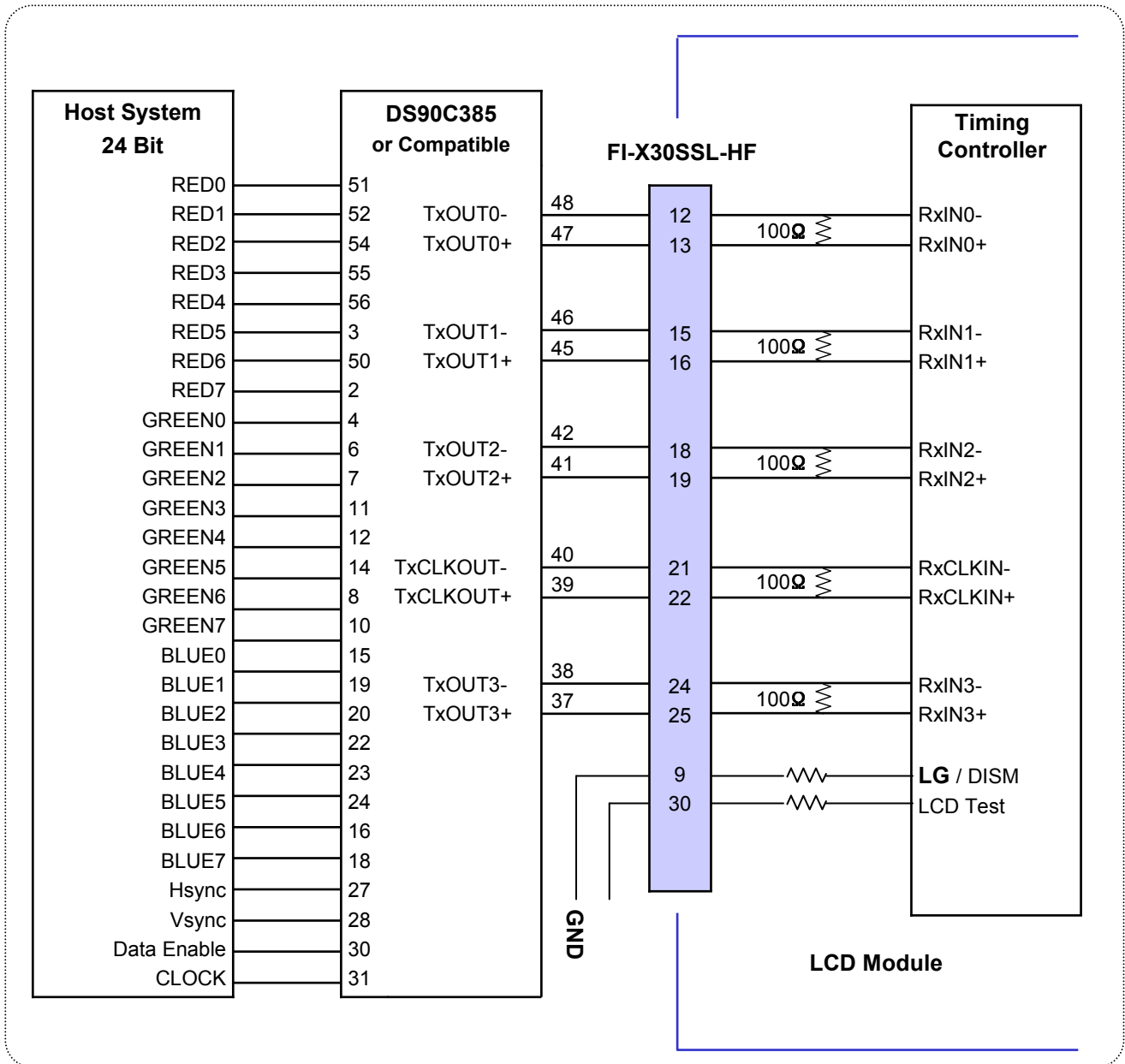

Note:

1. The LCD module uses a 100 Ohm(Ω) resistor between positive and negative lines of each receiver input.
2. Refer to LVDS transmitter data sheet for detail descriptions. (DS90C385 or Compatible)
3. '7' means MSB and '0' means LSB at R,G,B pixel data.

Product Specification

Table 6. Required signal assignment for LVDS transmitter (Pin9 = "H")

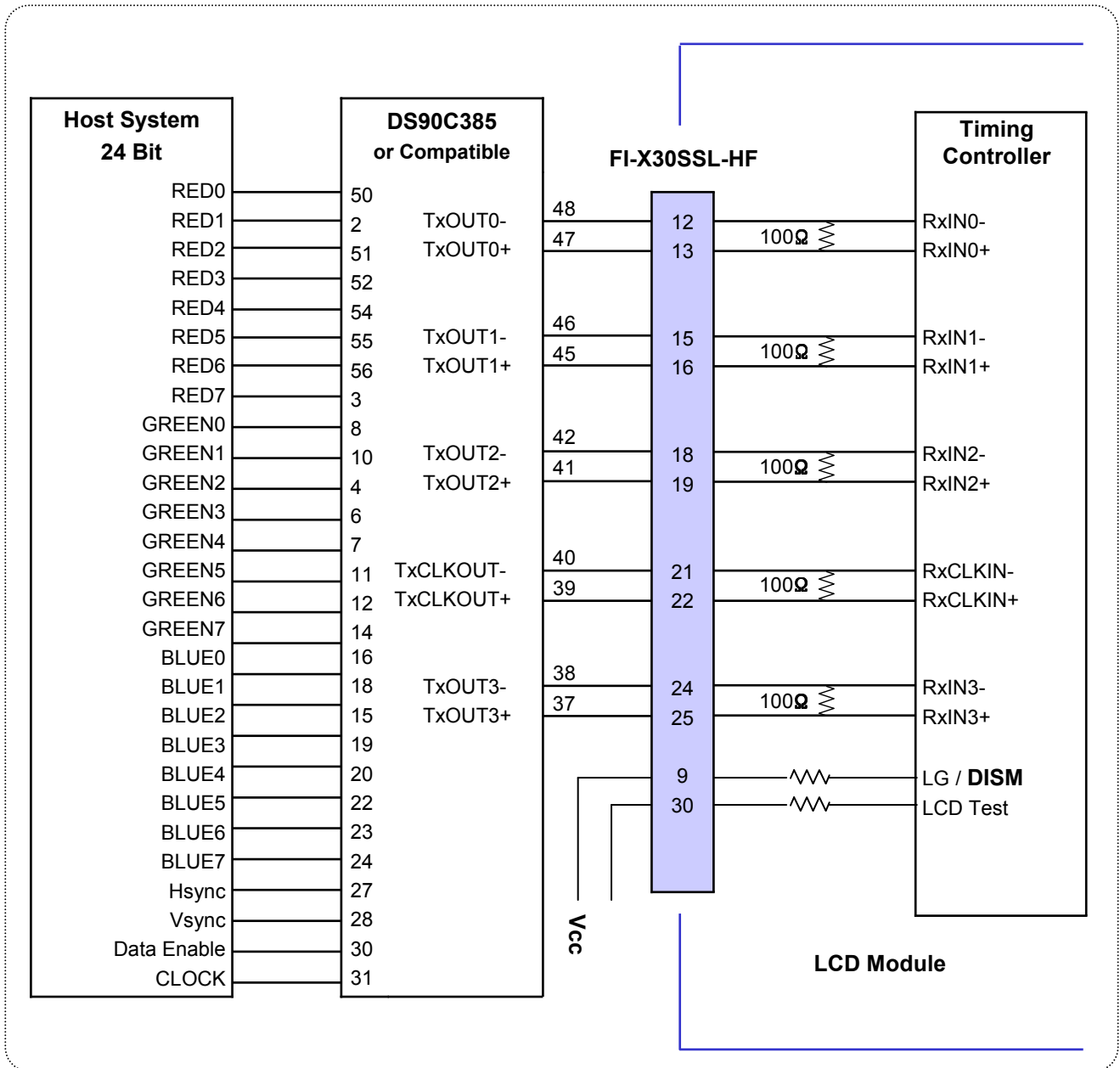

Note:

1. The LCD module uses a 100 Ohm(Ω) resistor between positive and negative lines of each receiver input.
2. Refer to LVDS transmitter data sheet for detail descriptions. (DS90C385 or Compatible)
3. '7' means MSB and '0' means LSB at R,G,B pixel data.

Product Specification

3-2-2. Backlight Inverter

Input CNT

- Inverter Connector : S14B-PH-SMC
(manufactured by JST) or Equivalent
- Mating Connector : PHR-14 or Equivalent

Table 7. INVERTER CONNECTOR PIN CONFIGURATION

Pin No	Symbol	Description	Master	Slave	Note
1	VBL	Power Supply +24.0V	VBL	VBL	
2	VBL	Power Supply +24.0V	VBL	VBL	
3	VBL	Power Supply +24.0V	VBL	VBL	
4	VBL	Power Supply +24.0V	VBL	VBL	
5	VBL	Power Supply +24.0V	VBL	VBL	
6	GND	Backlight Ground	GND	GND	
7	GND	Backlight Ground	GND	GND	
8	GND	Backlight Ground	GND	GND	1
9	GND	Backlight Ground	GND	GND	
10	GND	Backlight Ground	GND	GND	
11	Boost	DC(0.0V ~ 3.3V) input	Boost	Don't care	2
12	VON/OFF	0.0V ~ 5.0V	On/Off	Don't care	3, Open/High for B/L on as default
13	EXTVBR-B	PWM signal (0.0V ~ 3.3V) input	External PWM	-	4
14	Status	Normal : Under 0.7V Abnormal : External Pullup	Status	-	

- Notes :
1. GND should be connected to the LCD module's metal frame.
 2. Minimum Brightness : Boost = 0.0V Maximum Brightness : Boost = 3.3V "OPEN" : Boost = 1.65V
 3. Rising Edge : Lamp "ON" / Falling Edge : Lamp "OFF"
 4. Pin#13 can be opened. (if Pin #13 is open , EXTVBR-B is 100%)
 5. Each impedance of pin #11, 12 and 13 is 180[KΩ] , 80 [KΩ] and 5 [MΩ].

◆ Rear view of LCM

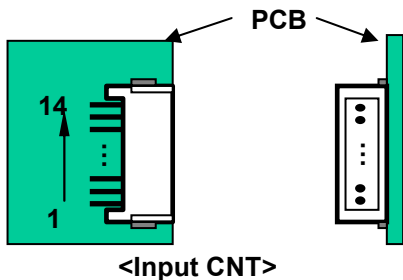

Product Specification

3-3. Signal Timing Specifications

This is the signal timing required at the input of the LVDS transmitter. All of the interface signal timing should be satisfied with the following specifications for it's proper operation.

Table 8. Timing Table

ITEM		SYMBOL	Min.	Typ.	Max.	Unit	Note
Clock	Period	t_{CLK}	12.2	13.8	14.7	ns	
	Frequency	f_{CLK}	68	72.3	82	MHz	
Hsync	Frequency	f_H	45	47.4	53	KHZ	3
	Display Valid	t_{HV}	1366	1366	1366	Clks	
	Blank	$t_{HT}-t_{HV}$	90	162	410	Clks	
	Total	t_{HT}	1456	1528	1776	Clks	
Vsync	Frequency	f_V	47	60	66	HZ	3
	Display Valid	t_{VV}	768	768	768	Lines	PAL: 47~53Hz, NTSC : 57~66Hz
	Blank	$t_{VT}-t_{VV}$	7	22	295	Lines	
	Total	t_{VT}	775	790	1063	Lines	

Notes:

1. The performance of the electro-optical characteristics are may be influenced by variance of the vertical refresh rates.
2. Above timing table is only valid for DE Mode.
3. H sync ,V sync don't care.(for only DE Mode)

Product Specification

3-4. Signal Timing Waveforms

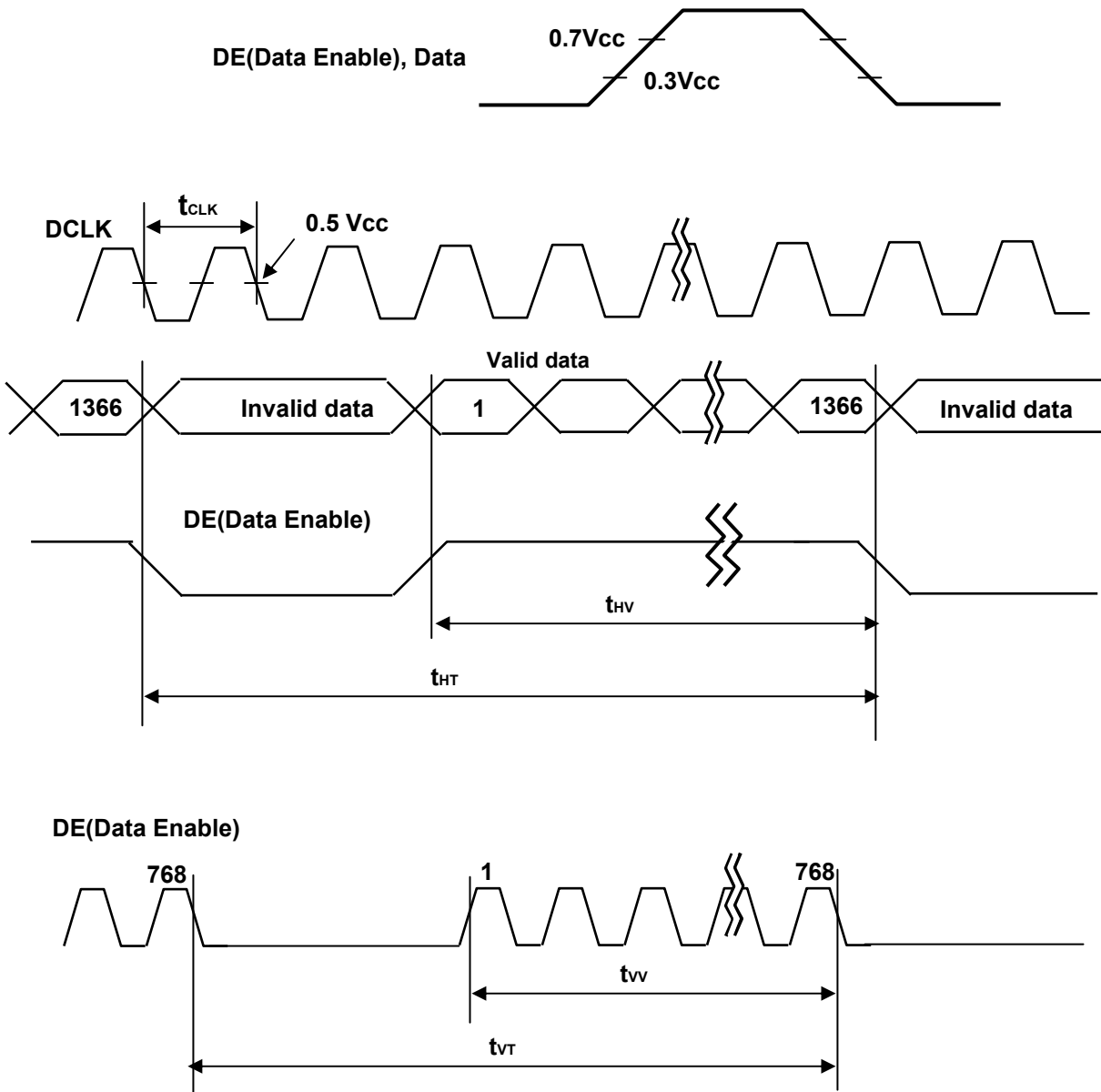

Product Specification

3-5. Color Input Data Reference

The brightness of each primary color (red, green and blue) is based on the 8-bit gray scale data input for the color ; the higher the binary input, the brighter the color.
The table below provides a reference for color versus data input.

Table 9. Color Data Reference

Color		Input Color Data																							
		Red								Green								Blue							
		MSB				LSB				MSB				LSB				MSB				LSB			
		R7	R6	R5	R4	R3	R2	R1	R0	G7	G6	G5	G4	G3	G2	G1	G0	B7	B6	B5	B4	B3	B2	B1	B0
Basic Color	Black	0	0	0	0	0	0	0	0	0	0	0	0	0	0	0	0	0	0	0	0	0	0	0	0
	Red (255)	1	1	1	1	1	1	1	1	0	0	0	0	0	0	0	0	0	0	0	0	0	0	0	0
	Green (255)	0	0	0	0	0	0	0	0	1	1	1	1	1	1	1	1	0	0	0	0	0	0	0	0
	Blue (255)	0	0	0	0	0	0	0	0	0	0	0	0	0	0	0	0	1	1	1	1	1	1	1	1
	Cyan	0	0	0	0	0	0	0	0	1	1	1	1	1	1	1	1	1	1	1	1	1	1	1	1
	Magenta	1	1	1	1	1	1	1	1	0	0	0	0	0	0	0	0	1	1	1	1	1	1	1	1
	Yellow	1	1	1	1	1	1	1	1	1	1	1	1	1	1	1	1	0	0	0	0	0	0	0	0
	White	1	1	1	1	1	1	1	1	1	1	1	1	1	1	1	1	1	1	1	1	1	1	1	1
Red	Red(000) Dark	0	0	0	0	0	0	0	0	0	0	0	0	0	0	0	0	0	0	0	0	0	0	0	0
	Red(001)	0	0	0	0	0	0	0	1	0	0	0	0	0	0	0	0	0	0	0	0	0	0	0	0
	Red(002)	0	0	0	0	0	0	1	0	0	0	0	0	0	0	0	0	0	0	0	0	0	0	0	0
	-----	-	-	-	-	-	-	-	-	-	-	-	-	-	-	-	-	-	-	-	-	-	-	-	-
	-----	-	-	-	-	-	-	-	-	-	-	-	-	-	-	-	-	-	-	-	-	-	-	-	-
	Red(253)	1	1	1	1	1	1	0	1	0	0	0	0	0	0	0	0	0	0	0	0	0	0	0	0
	Red(254)	1	1	1	1	1	1	1	0	0	0	0	0	0	0	0	0	0	0	0	0	0	0	0	0
Red(255) Bright	1	1	1	1	1	1	1	1	0	0	0	0	0	0	0	0	0	0	0	0	0	0	0	0	
Green	Green(000) Dark	0	0	0	0	0	0	0	0	0	0	0	0	0	0	0	0	0	0	0	0	0	0	0	0
	Green(001)	0	0	0	0	0	0	0	0	0	0	0	0	0	0	1	0	0	0	0	0	0	0	0	0
	Green(002)	0	0	0	0	0	0	0	0	0	0	0	0	0	1	0	0	0	0	0	0	0	0	0	0
	-----	-	-	-	-	-	-	-	-	-	-	-	-	-	-	-	-	-	-	-	-	-	-	-	-
	-----	-	-	-	-	-	-	-	-	-	-	-	-	-	-	-	-	-	-	-	-	-	-	-	-
	Green(253)	0	0	0	0	0	0	0	1	1	1	1	1	1	1	0	1	0	0	0	0	0	0	0	0
	Green(254)	0	0	0	0	0	0	0	1	1	1	1	1	1	1	1	0	0	0	0	0	0	0	0	0
Green(255) Bright	0	0	0	0	0	0	0	1	1	1	1	1	1	1	1	1	0	0	0	0	0	0	0	0	
Blue	Blue(000) Dark	0	0	0	0	0	0	0	0	0	0	0	0	0	0	0	0	0	0	0	0	0	0	0	0
	Blue(001)	0	0	0	0	0	0	0	0	0	0	0	0	0	0	0	0	0	0	0	0	0	0	0	1
	Blue(002)	0	0	0	0	0	0	0	0	0	0	0	0	0	0	0	0	0	0	0	0	0	0	1	0
	-----	-	-	-	-	-	-	-	-	-	-	-	-	-	-	-	-	-	-	-	-	-	-	-	-
	-----	-	-	-	-	-	-	-	-	-	-	-	-	-	-	-	-	-	-	-	-	-	-	-	-
	Blue(253)	0	0	0	0	0	0	0	0	0	0	0	0	0	0	0	0	1	1	1	1	1	1	0	1
	Blue(254)	0	0	0	0	0	0	0	0	0	0	0	0	0	0	0	0	1	1	1	1	1	1	1	0
Blue(255) Bright	0	0	0	0	0	0	0	0	0	0	0	0	0	0	0	0	1	1	1	1	1	1	1	1	

Product Specification

3-6. Power Sequence

3-6-1. Sequence for LCD Module

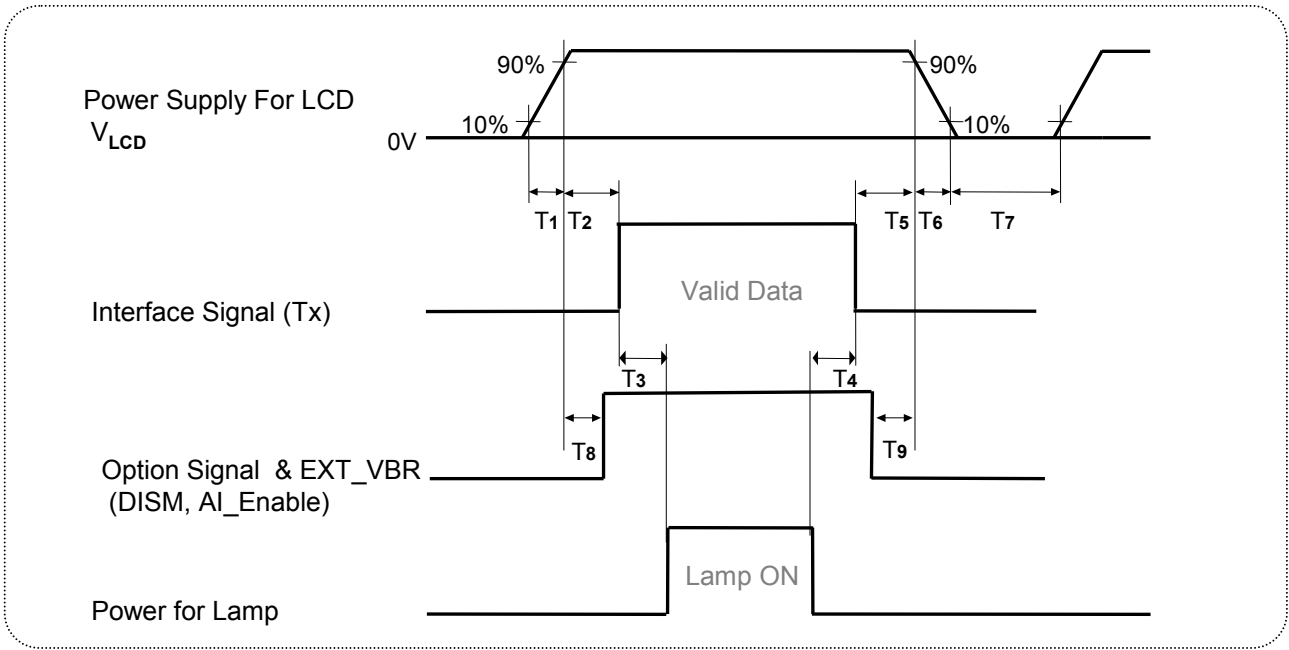

Table 10. Power Sequence for LCM

Parameter	Value			Unit
	Min	Typ	Max	
T1	0.01	-	20	ms
T2	0.01	-	50	ms
T3	200	-	-	ms
T4	200	-	-	ms
T5	0.01	-	50	ms
T6	-	-	-	ms
T7	2.0	-	-	s
T8	0 < T8 < T2			ms
T9	0 < T9 < T5			ms

- Notes :
1. Please avoid floating state of interface signal at invalid period.
 2. When the interface signal is invalid, be sure to pull down the power supply V_{LCD} to 0V.
 3. The case when the T2/T5 exceed maximum specification, it operates protection pattern(Black pattern) till valid signal inputted. There is no reliability problem.
 4. The T3/T4 is recommended value, the case when failed to meet a minimum specification, abnormal display would be shown. There is no reliability problem.

Product Specification

3-6-2. Sequence for Inverter

Power Supply For Inverter

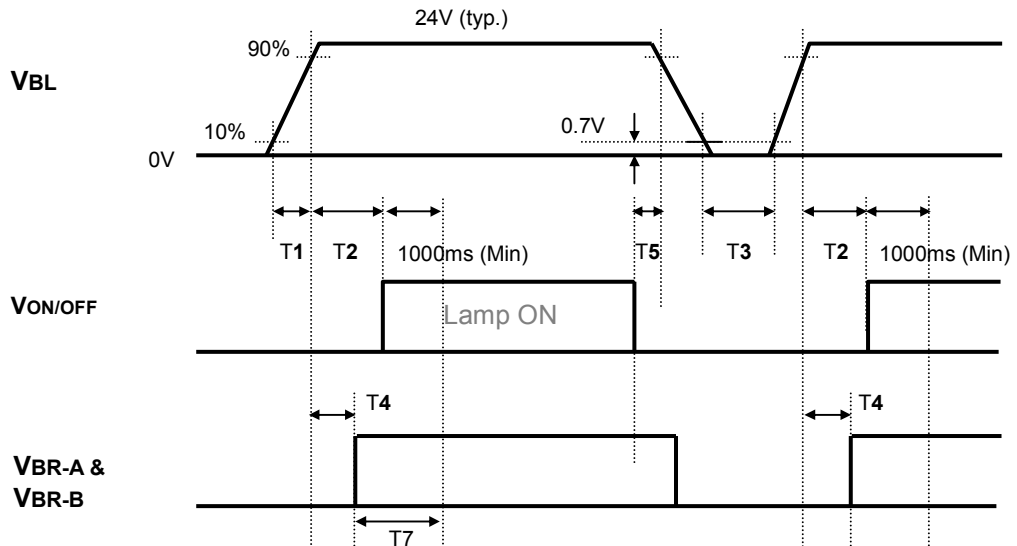

3-6-3. Deep condition for Inverter

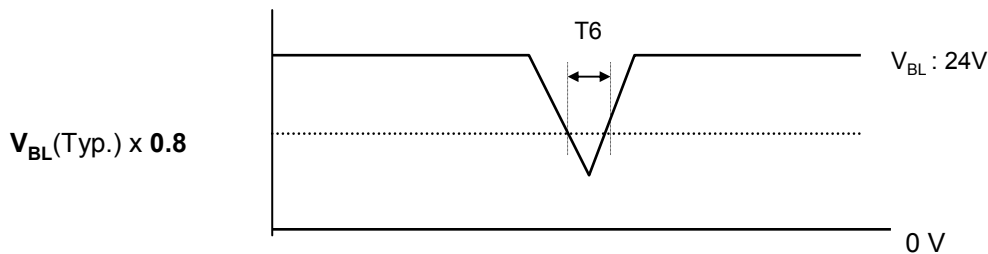

Table 12. Power Sequence for Inverter

Parameter	Values			Units	Remarks
	Min	Typ	Max		
T1	20	-	-	ms	1
T2	500	-	-	ms	
T3	200	-	-	ms	
T4	0	-	-	ms	2
T5	10	-	-	ms	
T6	-	-	10	ms	$V_{BL}(Typ) \times 0.8$
T7	1000	-	-	ms	3

- Notes : 1. T1 describes rising time of 0V to 24V and this parameter does not applied at restarting time.
 2. T4(max) is less than T2.
 3. In T7 section, VBR-B is recommended 3.3V.

Product Specification

4. Optical Specification

Optical characteristics are determined after the unit has been 'ON' for 30Min in a dark environment at $25 \pm 2^\circ\text{C}$. The values specified are at an approximate distance 50cm from the LCD surface at a viewing angle of Φ and θ equal to 0° .

FIG. 4 presents additional information concerning the measurement equipment and method.

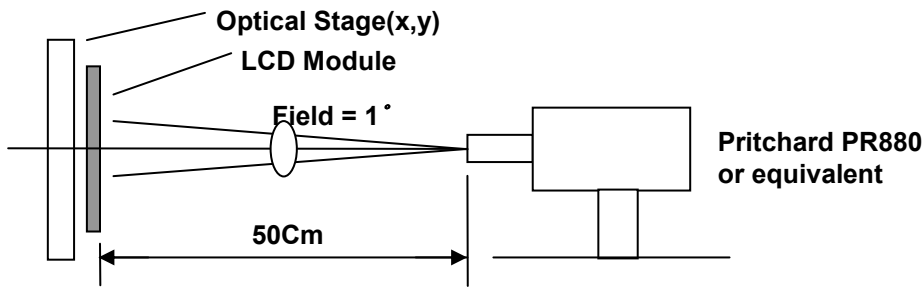

[Figure 4] Optical characteristic measurement equipment and method

Table 12. Optical characteristics ($T_a=25 \pm 2^\circ\text{C}$, $V_{LCD}=12\text{V}$, $f_v=60\text{Hz}$, $\text{CLK}=72.3\text{MHz}$, $V_{br-A} = 1.65$, $V_{br-B}=3.3\text{V}$, DCR Disable)

Parameter	Symbol	Value			Unit	Note	
		Min	Typ	Max			
Contrast Ratio	CR(DCR Off)	680	900			1	
	CR(DCR On)	-	-				
Surface Luminance, white	L_{WH}	360	450		cd/m ²	2	
Luminance Variation	δ_{WHITE}		-	1.3		3	
Response Time	Rise Time		TrR	9	16	ms	
	Decay Time		TrD	9	16	ms	
	Gray to Gray			8	16	ms	4
Color Coordinates							
Color Coordinates [CIE 1931]	RED	RX		0.633			
		RY		0.344			
	GREEN	GX		0.281			
		GY	Typ - 0.03	0.618	Typ +0.03		
	BLUE	BX		0.145			
		BY		0.061			
	WHITE	WX		0.279			
	WY		0.292				
Viewing Angle (CR>10)							
	x axis, right ($\phi=0^\circ$)	θ_r	85	89	-	degree	5
	x axis, left ($\phi=180^\circ$)	θ_l	85	89	-		
	y axis, up ($\phi=90^\circ$)	θ_u	85	89	-		
	y axis, down ($\phi=270^\circ$)	θ_d	85	89	-		
Gray scale			2.2				6

Product Specification

Note :

1. Contrast ratio(CR) is defined mathematically as :

$$\text{Contrast ratio} = \frac{\text{Surface luminance with all white pixels}}{\text{Surface luminance with all black pixels}}$$

It is measured at center point(1)

2. Surface luminance(L_{WH}) is luminance value at center point (P1) across the LCD surface 50cm from the surface with all pixels displaying white.

For more information see FIG 5.

3. The variation in surface luminance , δ_{WHITE} is defined as

$$\delta_{WHITE} = \text{Maximum (P1,P2,P5)} / \text{Minimum (P1,P2,P5)}$$

For more information see [Figure 5].

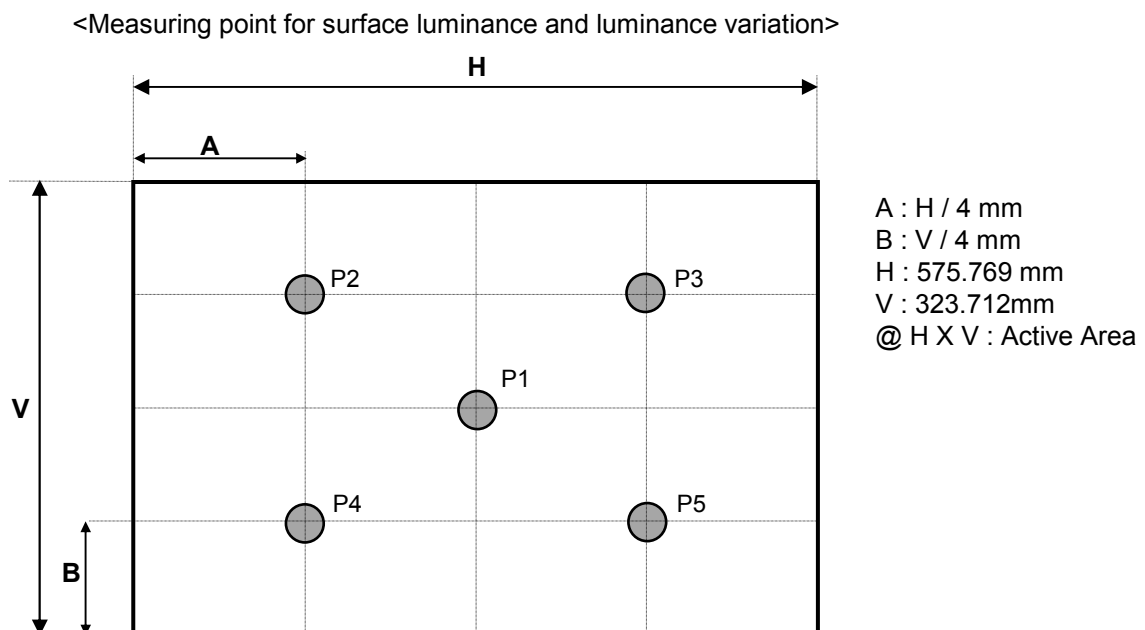

Figure 5. Luminance measuring point

Product Specification

4. Response time is defined as the following figure and shall be measured by switching the input signal for "Gray(N)" and "Gray(M)".

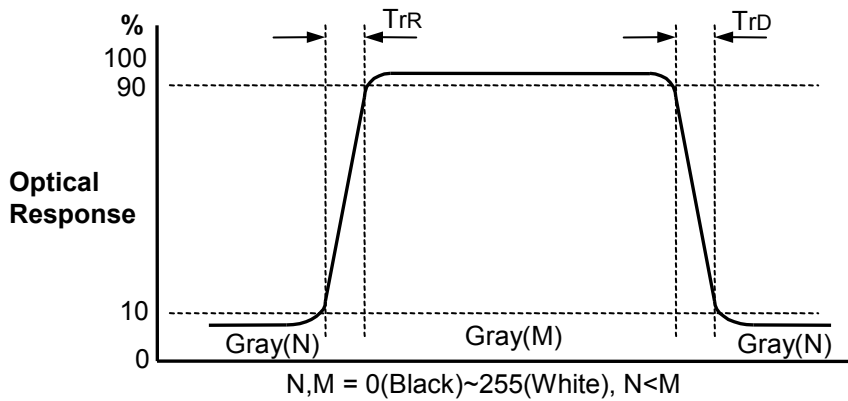

Figure 6. Response time

5. Viewing angle is the angle at which the contrast ratio is greater than 10. The angles are determined for the horizontal or x axis and the vertical or y axis with respect to the z axis which is normal to the LCD surface. For more information see Figure 7 .

<Dimension of viewing angle range>

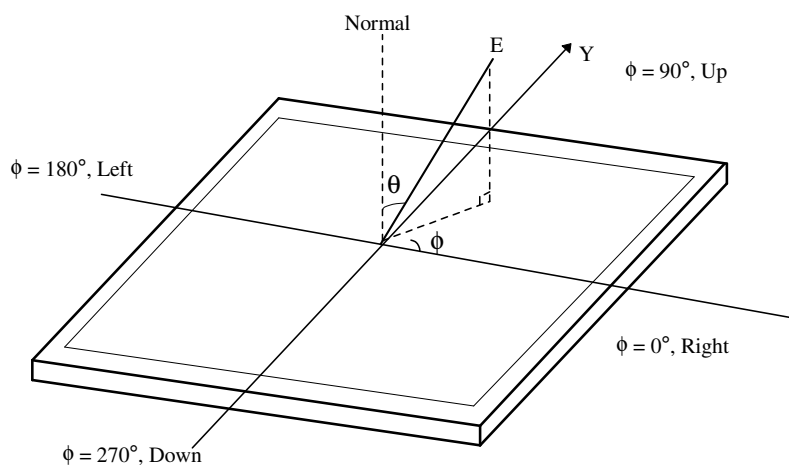

Figure 7. Viewing angle

Product Specification

6. Gray scale specification

Table 13. Gray scale

Gray Level	Luminance [%] Without DCR		
	Min.	Typ.	Max.
L0	0	0.12	0.15
L15	0	0.27	1.4
L31	0	1.00	2.7
L47	0	2.40	5
L63	0.5	4.60	9.1
L79	1.7	7.60	13.7
L95	4	11.4	19.1
L111	7.5	16.0	25.1
L127	11.8	21.6	32.9
L143	16.3	28.0	42
L159	22	35.4	50.5
L175	29.7	43.7	59.7
L191	39.4	53.0	69.5
L207	48.8	63.2	80.3
L223	61.5	74.5	90.6
L239	76.9	88.0	96.6
L255	100	100	100

7. Image sticking

When it changes into pattern-B after a 1-hour drive by pattern-A, it disappears within 10 minutes.

<Pattern-A, Chess board (8x6)>

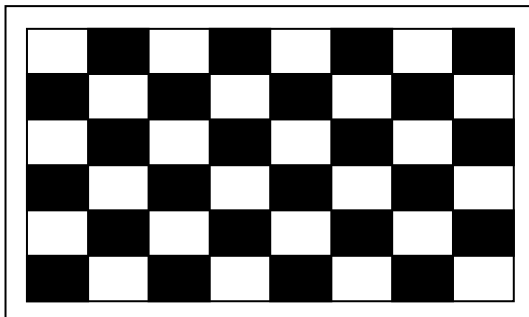

<Pattern-B, Mid-gray(127 gray)>

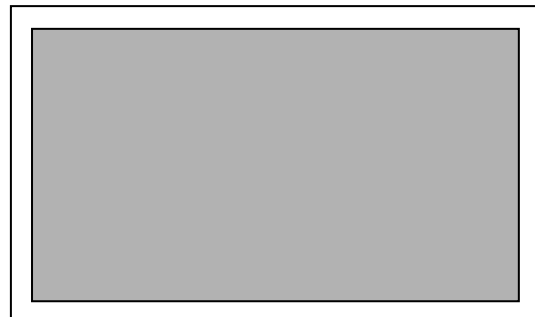

Product Specification

5. Mechanical Characteristics

Table 14. provides general mechanical characteristics for the model LC260WX2. In addition, the figures in the next page are detailed mechanical drawing of the LCD.

Table 14. Mechanical characteristics

Outline Dimension	Horizontal	626 mm
	Vertical	373 mm
	Depth	47.1 mm
Bezel Area	Horizontal	580.8mm
	Vertical	328.8mm
Active Display Area	Horizontal	575.769 mm
	Vertical	323.712 mm
Weight	4,300 (Typ.), 4,500 g (Max.)	
Surface Treatment	Hard coating(3H) Anti-glare treatment of the front polarizer	

Note : Please refer to a mechanic drawing in terms of tolerance at the next page.

Product Specification

<FRONT VIEW>

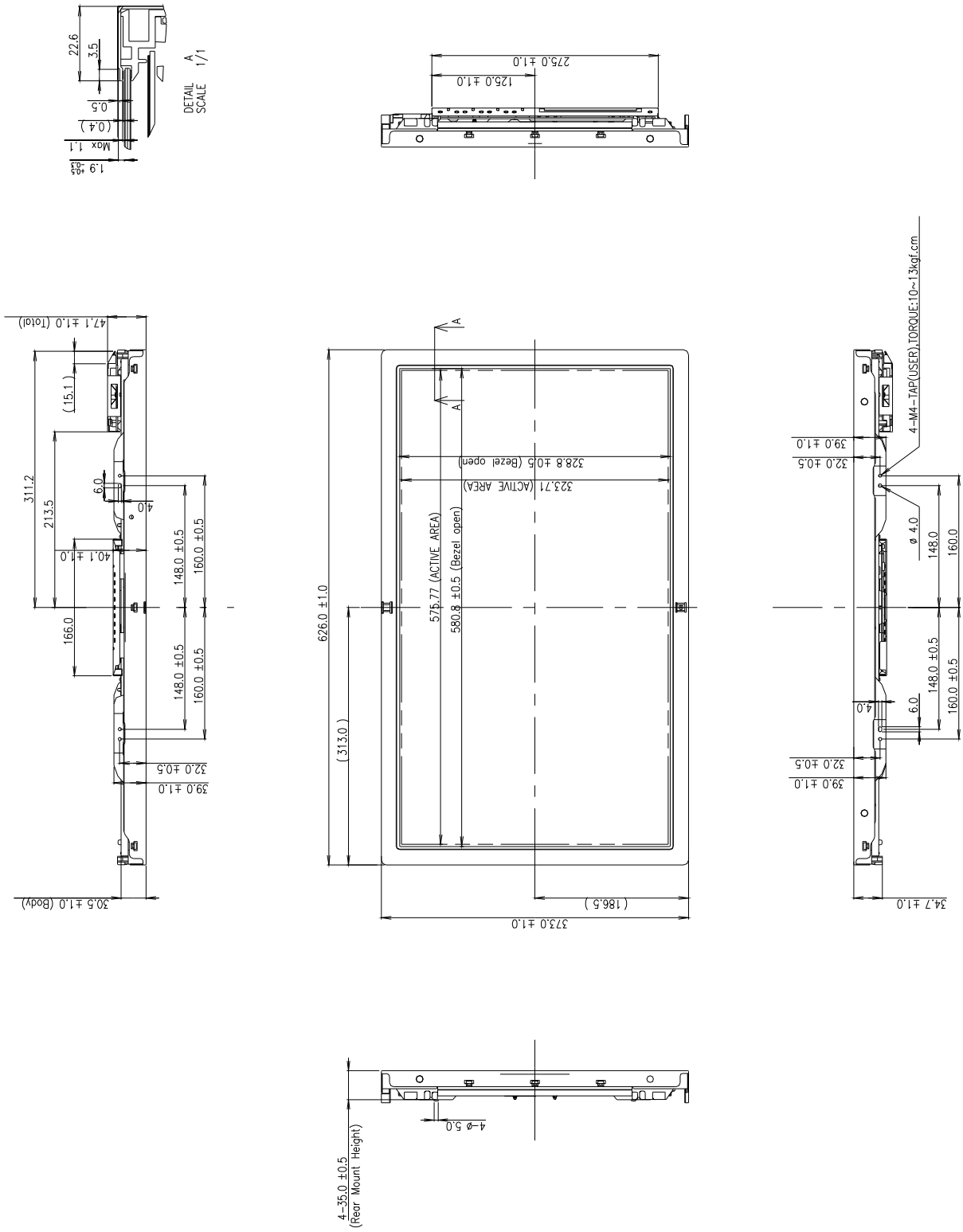

Product Specification

6. Reliability

Table 15. ENVIRONMENT TEST CONDITION

No	Test Item	Condition
1	High temperature storage test	60°C, 500h
2	Low temperature storage test	-20°C, 500h
3	High temperature operation test	50°C, 80%RH, 500h 60°C, 500h (2000h)
4	Low temperature operation test	0°C, 500h (1000h)
5	Heat cycle test	-20°C ~ 60°C, 30min/5min/30min, 100cycles
6	Soldering heat cycle test	-40°C ~ 80°C, 30min/5min/30min, 200cycles
7	Vibration test (non-operating)	Wave form : random Vibration level : 1.0Grms Bandwidth : 10-500Hz Duration : X,Y,Z, 10 min One time each direction
8	Shock test (non-operating)	Shock level : 100G Waveform : half sine wave, 2ms Direction : ±X, ±Y, ±Z One time each direction
9	ESD test	Condition : 150pF,330 ohm Case , air Evaluation : ± 15kV
10	Humidity Storage test	Ta= 40 °C ,70%RH(240hr)

Note : After Reliability Test , display function should be kept as the result evaluation.

Product Specification

<REAR VIEW>

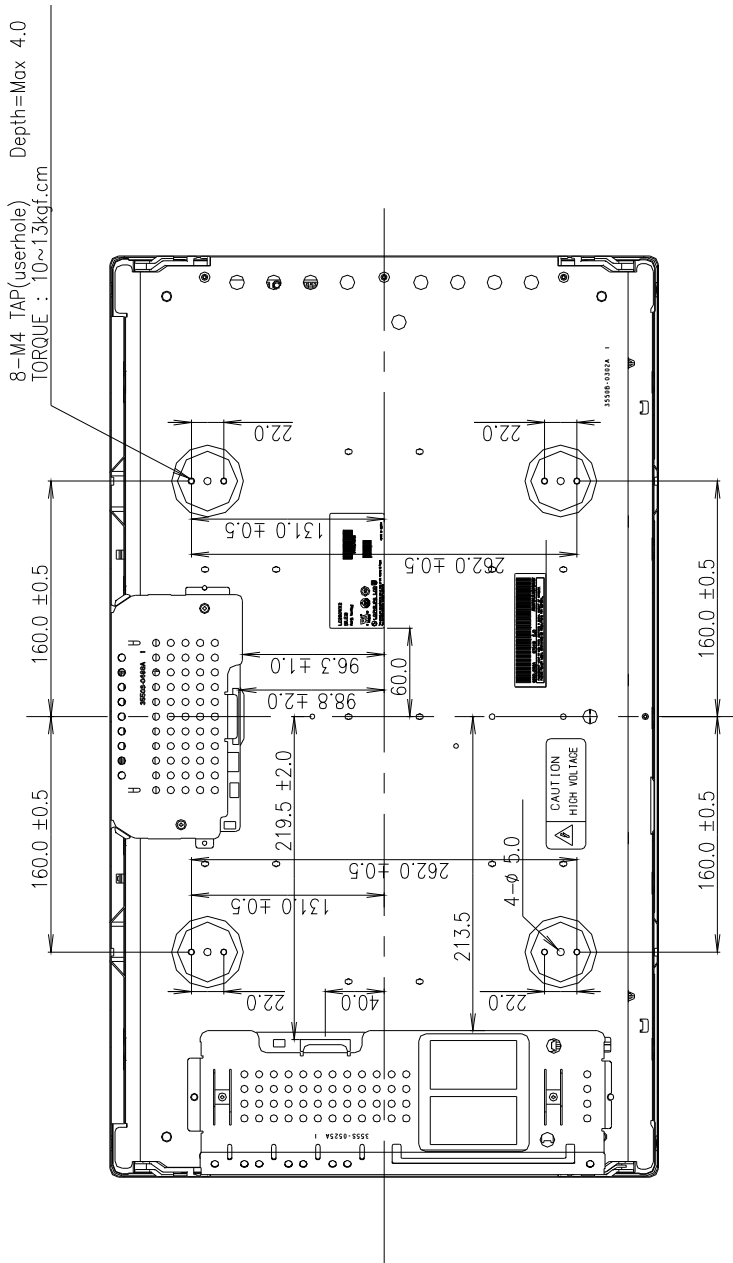

NOTES

1. Unspecified tolerances are to be ± 0.5 mm.
2. This drawing is only preliminary data and can be changed without notice.
3. Tilt and partial disposition tolerance of display area is as following.
 - (1) X-Direction : $IA-BI \leq 1.5$ mm
 - (2) Y-Direction : $IC-DI \leq 1.5$ mm

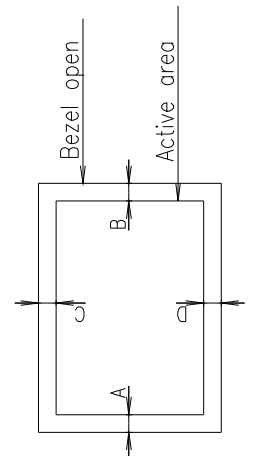

Product Specification**7. International Standards****7-1. Safety**

- a) UL 60950-1:2003, First Edition, Underwriters Laboratories, Inc., Standard for Safety of Information Technology Equipment.
- b) CAN/CSA C22.2, No. 60950-1-03 1st Ed. April 1, 2003, Canadian Standards Association, Standard for Safety of Information Technology Equipment.
- c) EN 60950-1:2001, First Edition, European Committee for Electrotechnical Standardization(CENELEC) European Standard for Safety of Information Technology Equipment.

7-2. EMC

- a) ANSI C63.4 "Methods of Measurement of Radio-Noise Emissions from Low-Voltage Electrical and Electrical Equipment in the Range of 9kHz to 40GHz." American National Standards Institute(ANSI), 1992
- b) C.I.S.P.R. "Limits and Methods of Measurement of Radio Interface Characteristics of Information Technology Equipment." International Special Committee on Radio Interference.
- c) EN 55022 "Limits and Methods of Measurement of Radio Interface Characteristics of Information Technology Equipment." European Committee for Electrotechnical Standardization.(CENELEC), 1998(Including A1: 2000)

Product Specification

8. Packing

8-1. Designation of Lot Mark

a) Lot Mark

A	B	C	D	E	F	G	H	I	J	K	L	M
---	---	---	---	---	---	---	---	---	---	---	---	---

A,B,C : SIZE(INCH)

E : MONTH

D : YEAR

F ~ M : SERIAL NO.

Note

1. YEAR

Year	2001	2002	2003	2004	2005	2006	2007	2008	2009	2010
Mark	1	2	3	4	5	6	7	8	9	0

2. MONTH

Month	Jan	Feb	Mar	Apr	May	Jun	Jul	Aug	Sep	Oct	Nov	Dec
Mark	1	2	3	4	5	6	7	8	9	A	B	C

b) Location of Lot Mark

Serial No. is printed on the label. The label is attached to the backside of the LCD module.
This is subject to change without prior notice.

8-2. Packing Form

a) Package quantity in one box :6 pcs

b) Box size : 752mm(W) X 506mm(D) X 458mm(H)

Product Specification

9. Precautions

Please pay attention to the followings when you use this TFT LCD module.

9-1. Mounting Precautions

- (1) You must mount a module using holes arranged in four corners or four sides.
- (2) You should consider the mounting structure so that uneven force (ex. Twisted stress) is not applied to the module. And the case on which a module is mounted should have sufficient strength so that external force is not transmitted directly to the module.
- (3) Please attach the surface transparent protective plate to the surface in order to protect the polarizer. Transparent protective plate should have sufficient strength in order to resist external force.
- (4) You should adopt a mounting structure to satisfy the temperature specification.
- (5) Acetic acid type and chlorine type materials for the cover case are not desirable because the former generates corrosive gas of attacking the polarizer at high temperature and the latter causes circuit break by electro-chemical reaction.
- (6) Do not touch, push or rub the exposed polarizers with glass, tweezers or anything harder than HB pencil lead. And please do not rub with dust clothes with chemical treatment. Do not touch the surface of polarizer for bare hand or greasy cloth. (Some cosmetics are detrimental to the polarizer.)
- (7) When the surface becomes dusty, please wipe gently with absorbent cotton or other soft materials like chamois soaks with petroleum benzene. Normal-hexane is recommended for cleaning the adhesives used to attach front / rear polarizers. Do not use acetone, toluene and alcohol because they cause chemical damage to the polarizer.
- (8) Wipe off saliva or water drops as soon as possible. Their long time contact with polarizer causes deformations and color fading.
- (9) Do not open the case because inside circuits do not have sufficient strength.

9-2. Operating Precautions

- (1) The spike noise causes the mis-operation of circuits. It should be lower than following voltage :
 $V = \pm 200\text{mV}$ (Over and under shoot voltage)
- (2) Response time depends on the temperature. (In lower temperature, it becomes longer.)
- (3) Brightness depends on the temperature. (In lower temperature, it becomes lower.)
And in lower temperature, response time (required time that brightness is stable after turned on) becomes longer.
- (4) Be careful for condensation at sudden temperature change. Condensation makes damage to polarizer or electrical contacted parts. And after fading condensation, smear or spot will occur.
- (5) When fixed patterns are displayed for a long time, remnant image is likely to occur.
- (6) Module has high frequency circuits. Sufficient suppression to the electromagnetic interference shall be done by system manufacturers. Grounding and shielding methods may be important to minimize the interference.
- (7) Please do not give any mechanical and/or acoustical impact to LCM. Otherwise, LCM can't be operated its full characteristics perfectly.
- (8) A screw which is fastened up the steels should be a machine screw.
(if not, it causes metallic foreign material and deal LCM a fatal blow)
- (9) Please do not set LCD on its edge.

Product Specification

9-3. Electrostatic Discharge Control

Since a module is composed of electronic circuits, it is not strong to electrostatic discharge. Make certain that treatment persons are connected to ground through wrist band etc. And don't touch interface pin directly.

9-4. Precautions for Strong Light Exposure

Strong light exposure causes degradation of polarizer and color filter.

9-5. Storage

When storing modules as spares for a long time, the following precautions are necessary.

- (1) Store them in a dark place. Do not expose the module to sunlight or fluorescent light. Keep the temperature between 5°C and 35°C at normal humidity.
- (2) The polarizer surface should not come in contact with any other object.
It is recommended that they be stored in the container in which they were shipped.

9-6. Handling Precautions for Protection Film

- (1) The protection film is attached to the bezel with a small masking tape.
When the protection film is peeled off, static electricity is generated between the film and polarizer.
This should be peeled off slowly and carefully by people who are electrically grounded and with well ion-blown equipment or in such a condition, etc.
- (2) When the module with protection film attached is stored for a long time, sometimes there remains a very small amount of glue still on the bezel after the protection film is peeled off.
- (3) You can remove the glue easily. When the glue remains on the bezel surface or its vestige is recognized, please wipe them off with absorbent cotton waste or other soft material like chamois soaked with normal-hexane.

Product Specification

APPENDIX- I

■ LC260WX2-SLE3-Packing AssY

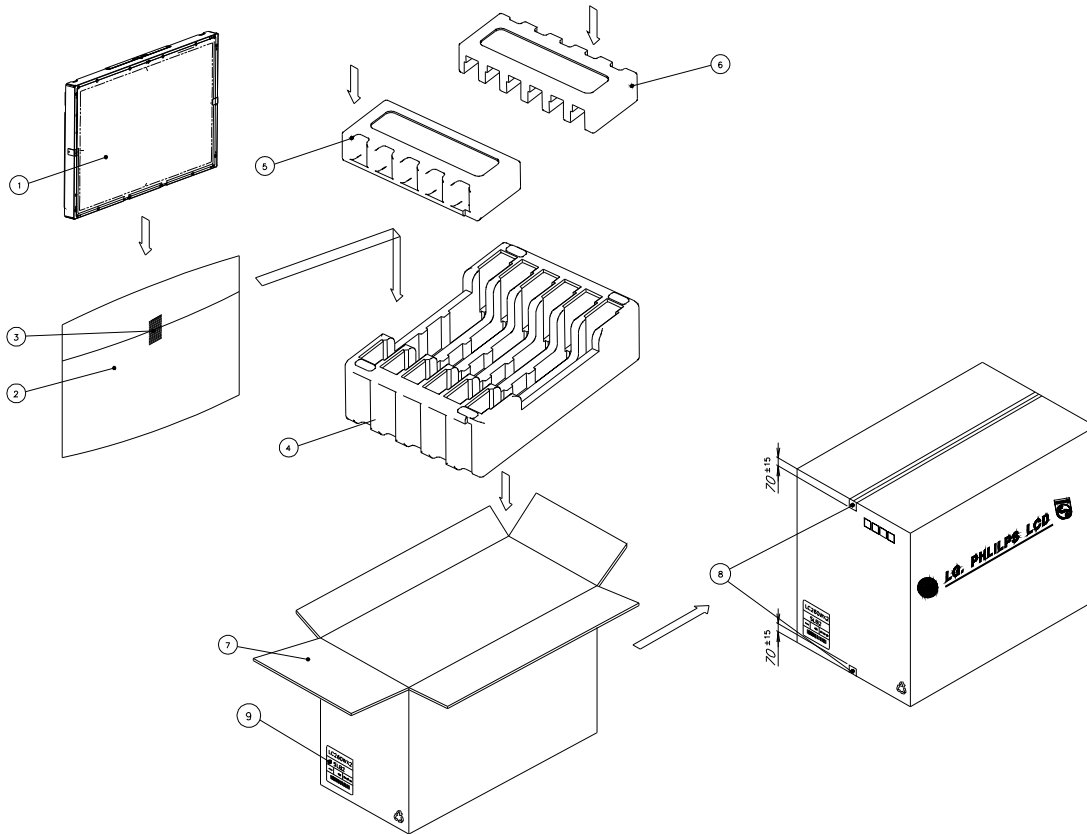

NO.	DESCRIPTION	MATERIAL
1	LCD Module	
2	BAG	AL
3	TAPE	MASKING 20MMX50M
4	Packing(B)	EPS
5/6	Packing(L/R)	EPS
7	BOX	KL(752x506X458)
8	TAPE	OPP 70MMX300M

Product Specification

APPENDIX- II

■ LC260WX2-SLE3 Pallet AssY

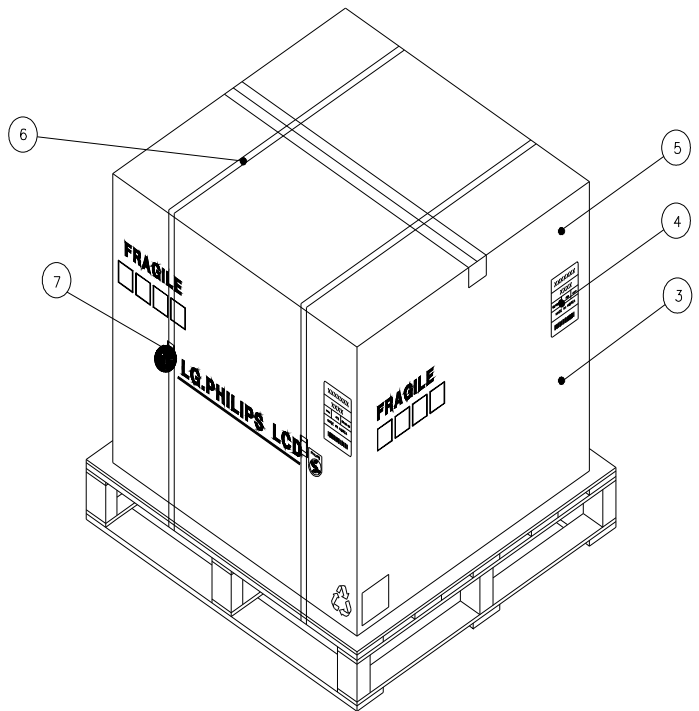
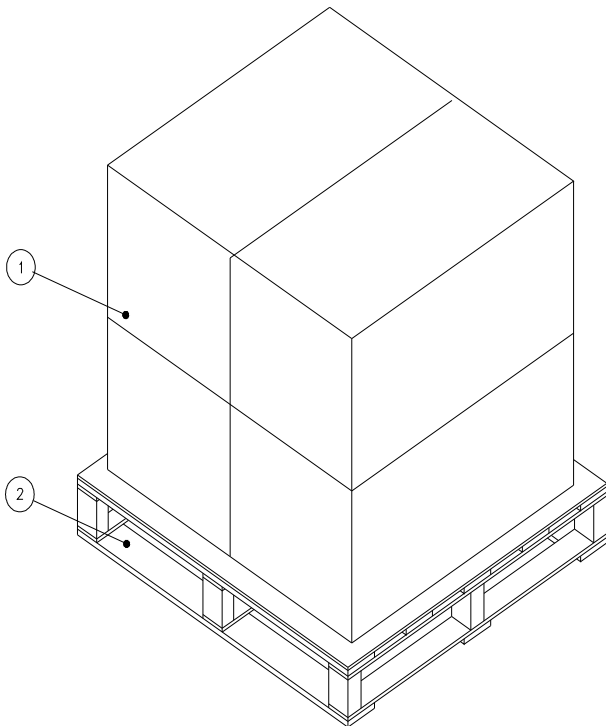

NO.	DESCRIPTION	MATERIAL
1	PACKING ASS'Y	
2	PALLET	PLYWOOD
3	ANGLE, PACKING	SW3
4	LABEL	YUPO PAPER
5	ANGLE, COVER	-
6	BAND	PP
7	BAND, CLIP	STEEL

Product Specification

■ **LCM Label**

APPENDIX-III

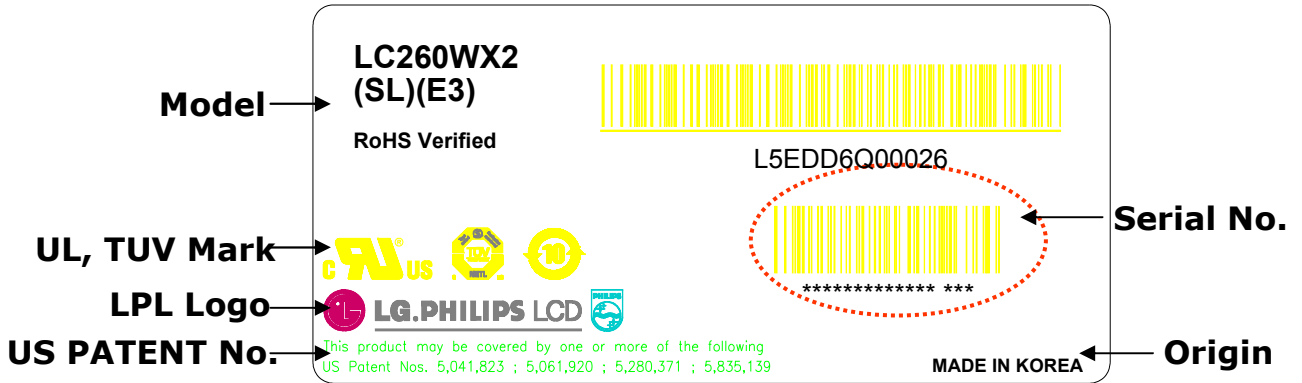

■ LCM Label



Product Specification

APPENDIX- IV

■ Box Label

LC260WX2		SLE3	
6 PCS	LOT/MM-DD		
MADE IN KOREA		RoHS Verified	
 <small>L5EDD6Q00026</small>			
 <small>*****</small>			

■ Pallet Label

LC260WX2		
SLE3		
24 PCS	LOT/MM-DD	
MADE IN KOREA		RoHS Verified
 <small>L5EDD6Q00026</small>		
 <small>*****</small>		