

mass integrated

global part distribution • product lifecycle partner
excess inventory management • value-ad service provider



Data sheet provided by Mass Integrated

massintegrated.com • displayalliance.com

Please call +1.978.465.6190
Email: sales@massintegrated.com



ISO 9001: 2008

Mass Integrated complies with all DMCA takedown notices. Please send a formal DMCA Takedown Notice to Mass Integrated Systems, Inc. • 18 Henry Graf Jr. Road, Unit 1 • Newburyport, MA 01950.

SHARP

No.	LD-K21761
DATE	Sep. 2, 2009

TENTATIVE

TECHNICAL LITERATURE
FOR
TFT - LCD module

MODEL No. LK816D3LA19

The technical literature is subject to change without notice.
So, please contact SHARP or its representative before designing
your product based on this literature.

ADVANCED TECHNOLOGY DEVELOPMENT CENTER
AVC LIQUID CRYSTAL DISPLAY GROUP
SHARP CORPORATION

1. Application

This technical literature applies to the color 81.6" TFT-LCD module LK816D3LA19.

- * These technical literature sheets are proprietary products of SHARP CORPORATION ("SHARP") and include materials protected under copyright of SHARP. Do not reproduce or cause any third party to reproduce them in any form or by any means, electronic or mechanical, for any purpose, in whole or in part, without the express written permission of SHARP.
- * In case of using the device for applications such as control and safety equipment for transportation (aircraft, trains, automobiles, etc.), rescue and security equipment and various safety related equipment which require higher reliability and safety, take into consideration that appropriate measures such as fail-safe functions and redundant system design should be taken.
- * Do not use the device for equipment that requires an extreme level of reliability, such as aerospace applications, telecommunication equipment (trunk lines), nuclear power control equipment and medical or other equipment for life support.
- * SHARP assumes no responsibility for any damage resulting from the use of the device that does not comply with the instructions and the precautions specified in these technical literature sheets.
- * Contact and consult with a SHARP sales representative for any questions about this device.

2. Overview

This module is a color active matrix LCD module incorporating amorphous silicon TFT (Thin Film Transistor). It is composed of a color TFT-LCD panel, driver ICs, control circuit, power supply circuit, inverter circuit and back light system etc. Graphics and texts can be displayed on a 1080×RGB×1920 dots panel with 16-million-colors by using LVDS (Low Voltage Differential Signaling) to interface, +12V of DC supply voltages.

This module also includes the DC/AC inverter to drive the CCFT. (+24V of DC supply voltage)

And in order to improve the response time of LCD, this module applies the Over Shoot driving (O/S driving) technology for the control circuit. In the O/S driving technology, signals are being applied to the Liquid Crystal according to a pre-fixed process as an image signal of the present frame when a difference is found between image signal of the previous frame and that of the current frame after comparing them.

By using the captioned process, the image signals of this LCD module are being set so that image response can be completed within one frame, as a result, image blur can be improved and clear image performance can be realized.

3. Mechanical Specifications

Parameter	Specifications	Unit
Display size	1812.6 (Diagonal)	mm
	81.9 (Diagonal)	inch
Active area	1015.74 (H) x 1805.76 (V)	mm
Pixel Format	1080 (H) x 1920 (V) (1pixel = R + G + B dot)	pixel
Pixel pitch	0.9405(H) x 0.9405 (V)	mm
Pixel configuration	R, G, B horizontal stripe	
Display mode	Normally black	
Unit Outline Dimensions (*1)	1094 (W) x 1879 (H) x (81.9)(D)	mm
Mass	(64.8)	kg
Surface treatment	Anti glare, low reflection coating Hard coating: 2H	

(*1) Outline dimensions are shown in Fig.1.

4. Input Terminals

4-1. TFT panel driving

CN1 (Interface signals) on CPWB

Using connector : FI-RE51S-VF (Japan Aviation Electronics Ind. , Ltd.)

Mating connector : FI-RE51HL (Japan Aviation Electronics Ind. , Ltd.)

Mating LVDS transmitter :THC63LVD1023B (THine) or equivalent device

Pin No.	Symbol	Function	Remark
1	FRAME1	Frame frequency setting H:60Hz L:50Hz	Pull up 3.3V(by 2.0kΩ)
2	TEMP0	Data3 of panel surface temperature[Note2,6]	Pull up 3.3V(by 2.0kΩ)
3	TEMP1	Data2 of panel surface temperature [Note2,6]	Pull up 3.3V(by 2.0kΩ)
4	TEMP2	Data1 of panel surface temperature [Note2,6]	Pull up 3.3V(by 2.0kΩ)
5	H_TEMP_Error	Error output at the ultra high temperature [Note 7] H: 3.3V (When protection function operates) L: 0V (At normal operation)	
6	U/D	Vertical shift direction[Note 4]	Pull down GND(by2.0kΩ)
7	SELLVDS	Select LVDS data order [Note 3]	Pull up 3.3V(by 2.0kΩ)
8	O/S SET	O/S operation setting H:O/S_ON, L:O/S_OFF [Note2,6]	Pull up 3.3V(by 2.0kΩ)
9	INV duty	Inverter Brightness Control [Note 5]	
10	INV_ON/OFF	Inverter ON/OFF setting H:ON, L:OFF	
11	GND	[Note 1]	
12	AIN0-	Aport (-)LVDS CH0 differential data input	
13	AIN0+	Aport (+)LVDS CH0 differential data input	
14	AIN1-	Aport (-)LVDS CH1 differential data input	
15	AIN1+	Aport (+)LVDS CH1 differential data input	
16	AIN2-	Aport (-)LVDS CH2 differential data input	
17	AIN2+	Aport (+)LVDS CH2 differential data input	
18	GND	[Note 1]	
19	ACK-	Aport LVDS Clock signal(-)	
20	ACK+	Aport LVDS Clock signal(+)	
21	GND	[Note 1]	
22	AIN3-	Aport (-)LVDS CH3 differential data input	
23	AIN3+	Aport (+)LVDS CH3 differential data input	
24	Reserved	It is required to set non-connection (OPEN).	
25	Reserved	It is required to set non-connection (OPEN).	
26	GND	[Note 1]	
27	GND	[Note 1]	
28	BIN0-	Bport (-)LVDS CH0 differential data input	
29	BIN0+	Bport (+)LVDS CH0 differential data input	
30	BIN1-	Bport (-)LVDS CH1 differential data input	
31	BIN1+	Bport (+)LVDS CH1 differential data input	
32	BIN2-	Bport (-)LVDS CH2 differential data input	
33	BIN2+	Bport (+)LVDS CH2 differential data input	
34	GND	[Note 1]	
35	BCK-	Bport LVDS Clock signal(-)	
36	BCK+	Bport LVDS Clock signal(+)	
37	GND	[Note 1]	
38	BIN3-	Bport (-)LVDS CH3 differential data input	
39	BIN3+	Bport (+)LVDS CH3 differential data input	
40	Reserved	It is required to set non-connection (OPEN).	
41	Reserved	It is required to set non-connection (OPEN).	
42	GND	[Note 1]	
43	GND	[Note 1]	

44	GND	[Note 1]	
45	GND	[Note 1]	
46	GND	[Note 1]	
47	NC	It is required to set non-connection (OPEN).	
48	NC	It is required to set non-connection (OPEN).	
49	NC	It is required to set non-connection (OPEN).	
50	NC	It is required to set non-connection (OPEN).	
51	NC	It is required to set non-connection (OPEN).	

CN2 on CPWB

Using connector : SM04B-PASS-TBT (J.S.T. Mfg Co.,Ltd.)

Mating connector : PAP-04V-S (J.S.T. Mfg Co.,Ltd.)

Pin No.	Symbol	Function	Remark
1	VCC	+12V Power Supply	
2	VCC	+12V Power Supply	
3	GND	GND	
4	GND	GND	

Interface block diagram

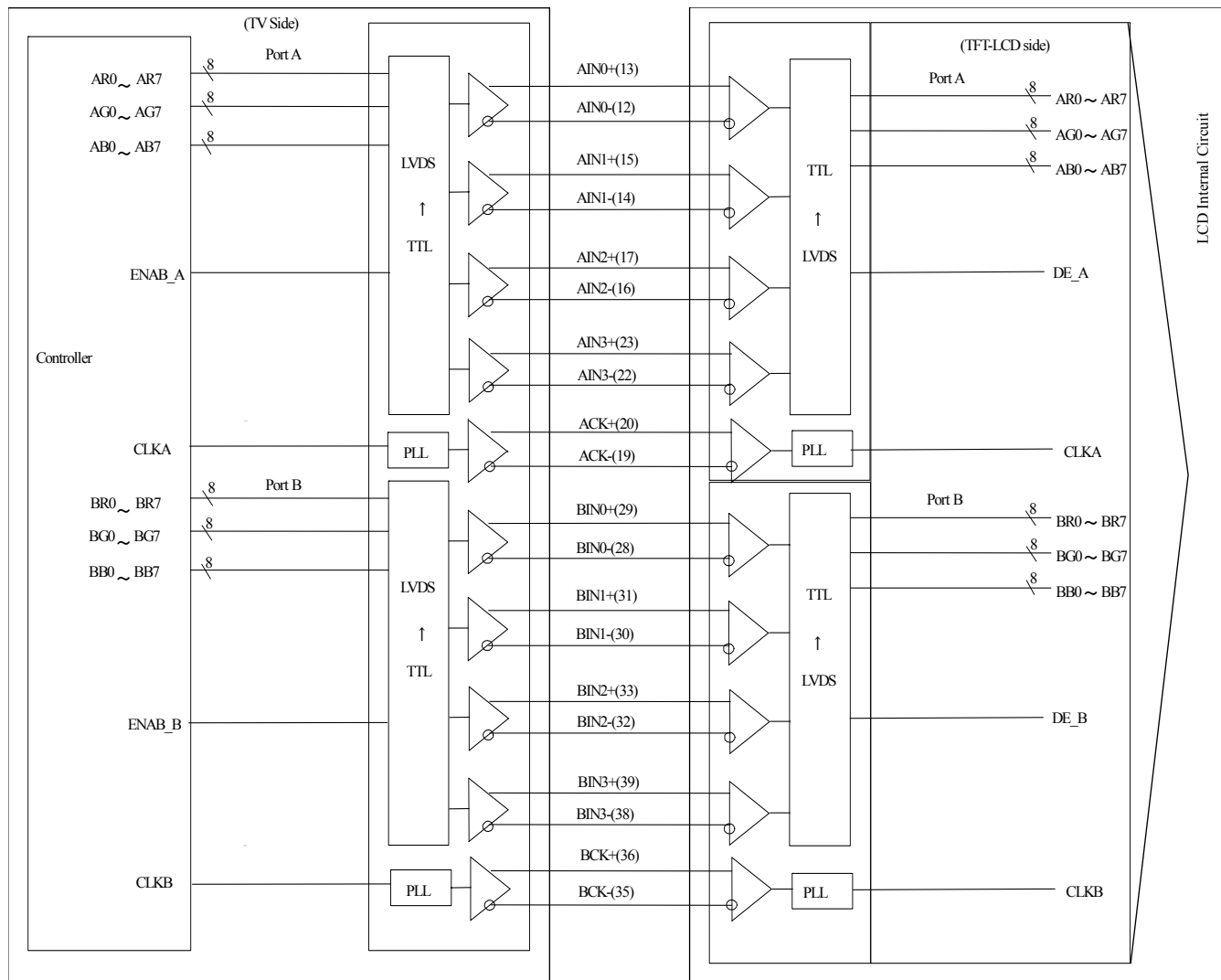

Corresponding Transmitter: THC63LVD1023B (Thine) or equivalent device

• Block Diagram (LCD Module)

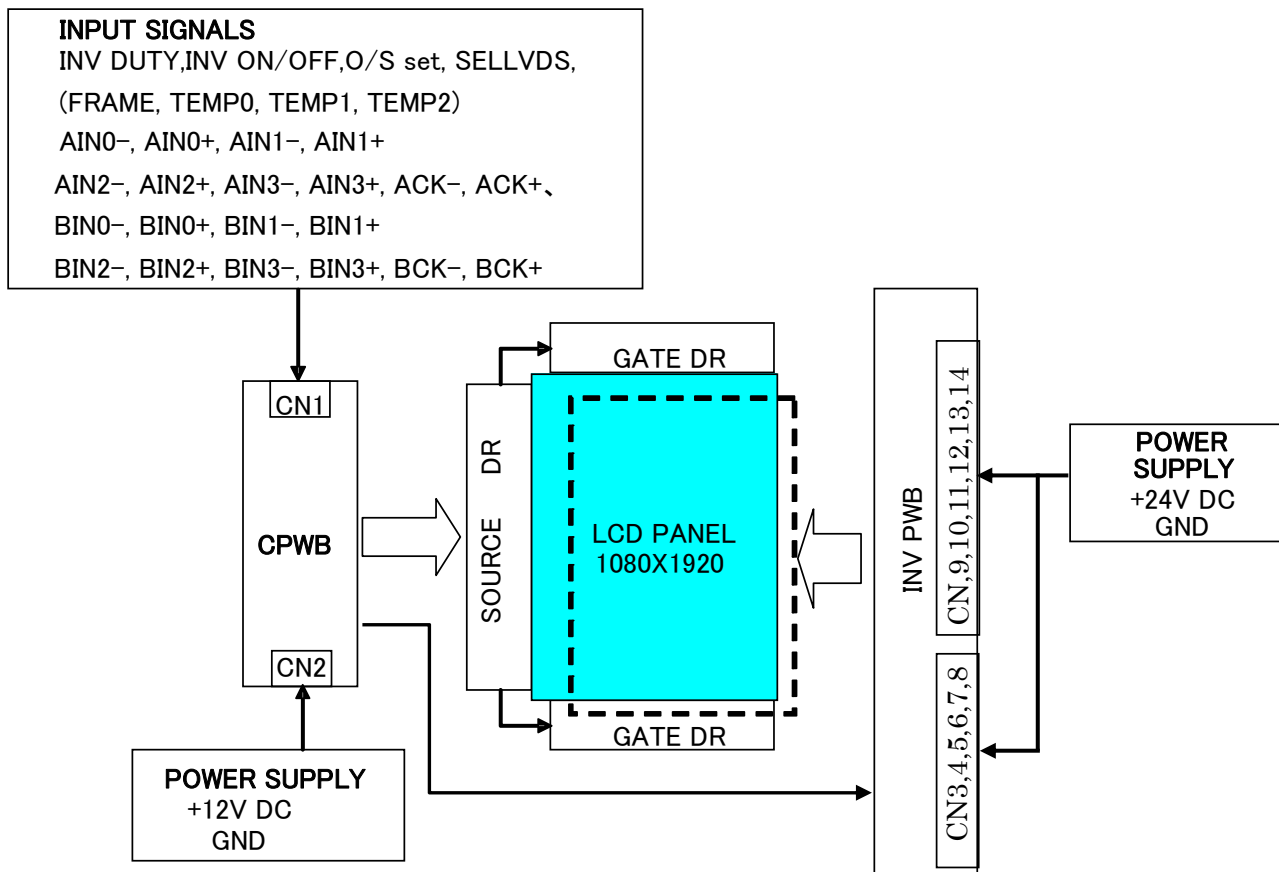

[Note1] GND of a liquid crystal panel drive part has connected with a module chassis.

[Note2] In case of O/S set setting "0"(O/S_OFF), it should be set the Temp0~2 to "0".

[Note 3] LVDS data order

Transmitter Data	SELLVDS = "L"(GND) LVDS data	SELLVDS = "H"(3.3V) or Open LVDS data
TA0	R0(LSB)	R2
TA1	R1	R3
TA2	R2	R4
TA3	R3	R5
TA4	R4	R6
TA5	R5	R7(MSB)
TA6	G0(LSB)	G2
TB0	G1	G3
TB1	G2	G4
TB2	G3	G5
TB3	G4	G6
TB4	G5	G7(MSB)
TB5	B0(LSB)	B2
TB6	B1	B3
TC0	B2	B4
TC1	B3	B5
TC2	B4	B6
TC3	B5	B7(MSB)
TC4	NA	NA
TC5	NA	NA
TC6	DE(*)	DE(*)
TD0	R6	R0(LSB)
TD1	R7(MSB)	R1
TD2	G6	G0(LSB)
TD3	G7(MSB)	G1
TD4	B6	B0(LSB)
TD5	B7(MSB)	B1
TD6	NA	NA

NA: Not Available

DE: Display Enable

(*) Since the display position is prescribed by the rise of DE (Display Enable) signal, please do not fix DE signal during operation at "High".

• LVDS data order (SELLVDS = "L")

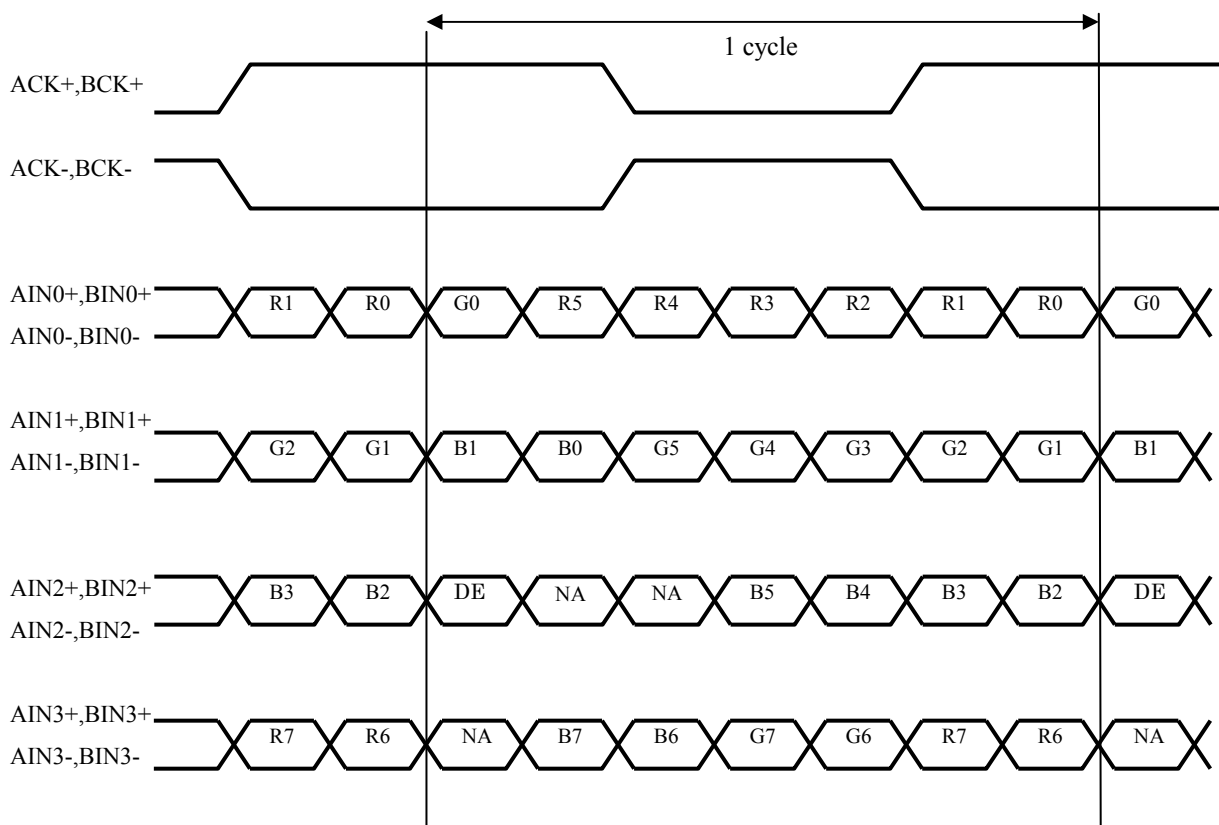

• LVDS data order (SELLVDS = "H")

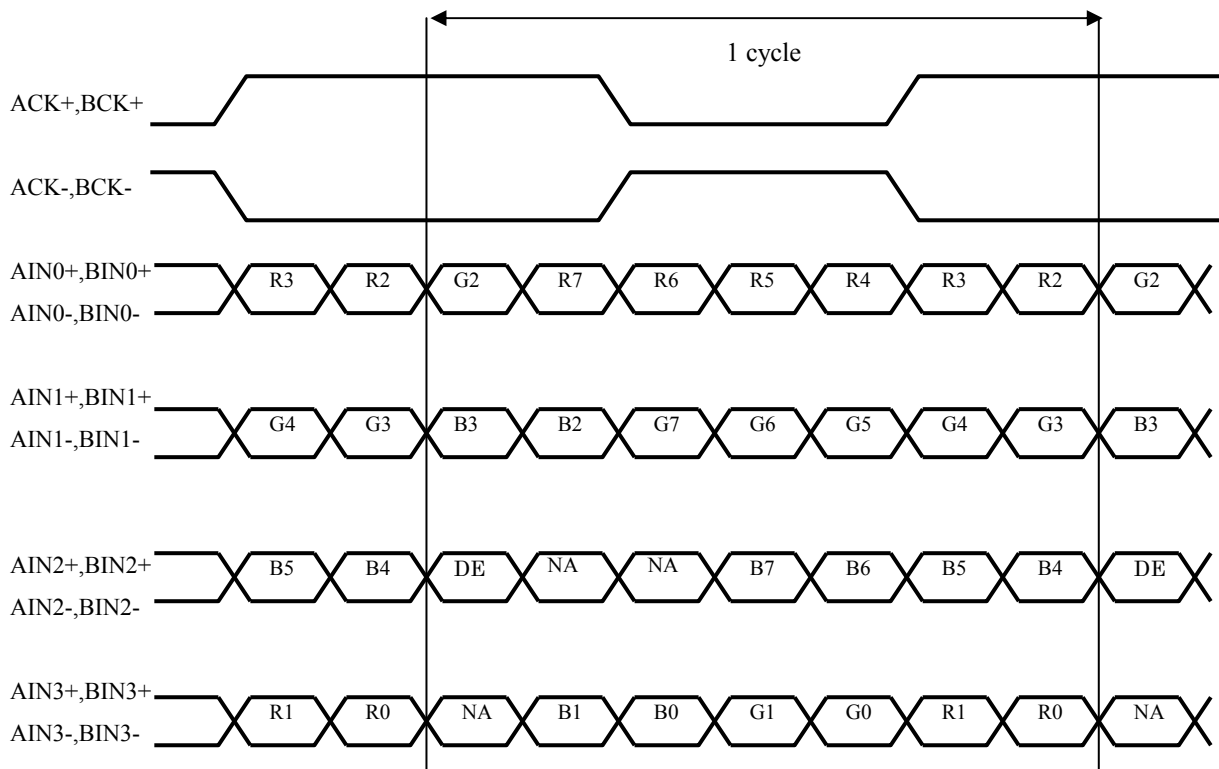

DE: Display Enable

NA: Not Available (Fixed Low)

[Note 4] Display reversal function

Normal (Default)

U/D : L (GND)

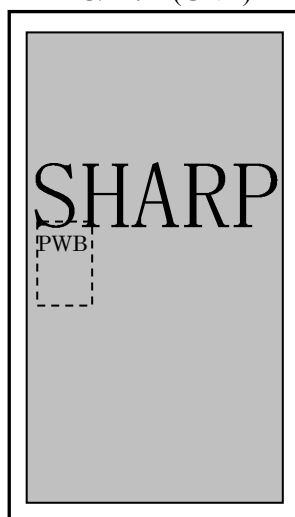

Vertical reverse imag

U/D : H (3.3V)

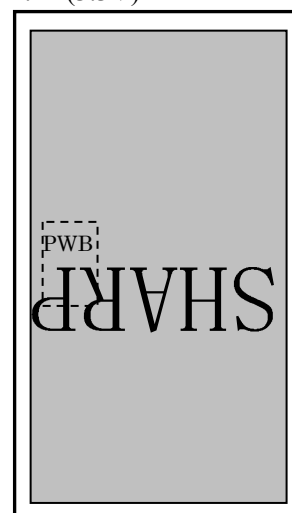

[Note 5] Brightness Control (Pulse PWM Dimming)

Pin No. 9 is used for the control of the PWM duty with input pulse.

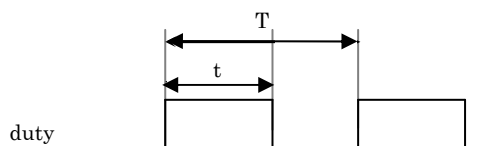

Ta = 25°C

		MIN	TYP	MAX	Remark
Pulse signal	[Hz]	140	165	350	
DUTY (t/T)	[%]	20	-	100	

[Note] There is a case that lamp mura may happen, depending on ambient temperature, in dimming. Minimum dimming level should be set according to your evaluation of actual display performance. (Minimum duty 60% at below 15°C)

[Note 6] O/S Setting (TBD)

According as the surface temperature of the panel, enter the optimum 3 bit signal into pin No.2,3,4.

Measuring the correlation between detected temperature by the sensor on PWB in users side and actual surface temperature of panel at center, convert the temperature detected by the sensor to the surface temperature of panel to enter the 3 bit temperature data.

Pin no.	Surface temperature of panel							
	(0-5)°C	(5-10) °C	(10-15) °C	(15-20) °C	(20-25) °C	(25-30) °C	(30-35) °C	(35)°C and above
2	0	0	0	0	1	1	1	1
3	0	0	1	1	0	0	1	1
4	0	1	0	1	0	1	0	1

*0: Low level voltage (GND) 1: High level voltage(3.3V)

*For overlapping temperatures (such as 5°C,10°C,15°C,20°C,25°C, 30°C,35°C) select the optimum parameter, judging from the actual picture image.

[Note 7] Error output at the ultra high temperature

For the protection of the module C_PWB decreases DUTY of PWM of the inverter to 30% forcibly when the temperature of the module is more than (85) °C. Duty of PWM of the inverter returns to a normal state afterwards when the temperature of the module is less than (55) °C.

Error output is Low(0V) at normal state . Error output becomes High (3.3V) when protection function operates.

4-2. Backlight driving

Inverter connector1 (+24V DC power supply and inverter control)

CN3, CN4, CN5, CN6, CN7, CN8 (Inverter Power input Pin layout)

Using connector: S14B-PH-K-S (LF) (J.S.T. Mfg Co.,Ltd.)

Mating connector: PHR-14 (J.S.T. Mfg Co.,Ltd.)

Pin No.	Symbol	Function
1	V _{INV}	+24V
2	V _{INV}	+24V
3	V _{INV}	+24V
4	V _{INV}	+24V
5	V _{INV}	+24V
6	GND	GND
7	GND	GND
8	GND	GND
9	GND	GND
10	GND	GND
11	Reserved	It is required to set non-connection (OPEN).
12	Reserved	It is required to set non-connection (OPEN).
13	Reserved	It is required to set non-connection (OPEN).
14	Reserved	It is required to set non-connection (OPEN).

Inverter connector2 (+24V DC power supply)

CN9, CN10, CN11, CN12, CN13, CN14 (Inverter Power input Pin layout)

Using connector: S12B-PH-K-S(LF) (J.S.T. Mfg Co.,Ltd.)

Mating connector: PHR-12 (J.S.T. Mfg Co.,Ltd.)

Pin No.	Symbol	Function
1	V _{INV}	+24V
2	V _{INV}	+24V
3	V _{INV}	+24V
4	V _{INV}	+24V
5	V _{INV}	+24V
6	GND	GND
7	GND	GND
8	GND	GND
9	GND	GND
10	GND	GND
11	Reserved	It is required to set non-connection (OPEN)
12	Reserved	It is required to set non-connection (OPEN)

4-3. The back light system characteristics

The back light system is direct type with 120 CCFTs (Cold Cathode Fluorescent Tube).

The characteristics of the lamp are shown in the following table.

The value mentioned below is at the case of one CCFT.

Item	Symbol	Min.	Typ.	Max.	Unit	Remarks
Life time	T_L	-	(60000)	-	Hour	[Note]

- [Note] • Lamp life time is defined as the time when brightness becomes 50% of the original value in the continuous operation under the condition of $T_a=25\text{ }^\circ\text{C}$ and brightness control(duty=100%).
- Above value is applicable when the long side of LCD module is placed vertically (Portrait position).

5. Absolute Maximum Ratings

Parameter	Symbol	Condition	Ratings	Unit	Remark
Input voltage (for Control)	V_I	$T_a=25\text{ }^\circ\text{C}$	-0.3 ~ 3.6	V	[Note 1]
12V supply voltage (for Control)	VCC	$T_a=25\text{ }^\circ\text{C}$	0 ~ +14	V	
Input voltage (for Inverter)	INV_{duty} $INV_{on/off}$	$T_a=25\text{ }^\circ\text{C}$	0 ~ +6	V	
24V supply voltage (for Inverter)	V_{INV}	$T_a=25\text{ }^\circ\text{C}$	0 ~ +27	V	
Storage temperature	Tstg	-	-20~ +60	$^\circ\text{C}$	[Note 2] [Note 3]
Operation temperature (Ambient)	Topa	-	(-10) ~ (+35)	$^\circ\text{C}$	[Note 3] [Note 4] [Note 5]

[Note 1]Frame, SELLVDS, O/S set, Temp1, Temp2, Temp3

[Note 2]Humidity 95%RH Max.($T_a \leq 40^\circ\text{C}$)

Maximum wet-bulb temperature at $39\text{ }^\circ\text{C}$ or less.($T_a > 40\text{ }^\circ\text{C}$) / No condensation.

[Note 3] Temperature Uniformity : $10\text{ }^\circ\text{C}$ Max.

[Note 4] Glass surface temperature : $55\text{ }^\circ\text{C}$ Max,

[Note 5] The temperature when the lamps are turned on should be (0)~(+35) $^\circ\text{C}$

6. Electrical Characteristics

6-1. Control circuit driving

Ta=25 °C

Parameter		Symbol	Min.	Typ.	Max.	Unit	Remark
+12V supply voltage	Supply voltage	V _{CC}	(11.4)	12.0	(12.5)	V	[Note 1]
	Current	I _{CC}	-	(0.9)	(1.5)	A	[Note 2,3]
Permissible input ripple voltage		V _{RP}	-	-	100	mV _{P-P}	V _{CC} = +12.0V
Differential input threshold voltage	High	V _{TH}	-	-	100	mV	V _{CM} = +1.2V [Note 4]
	Low	V _{TL}	-100	-	-	mV	
Input Low voltage		V _{IL}	-	-	0.8	V	[Note 5]
Input High voltage		V _{IH}	(2.0)	3.3	3.5	V	
Input leak current (High)		I _{IH}			(40)	μA	V _I =3.3V [Note 5]
Input leak current (Low)		I _{IL}	-	-	(400)	μA	V _I = 0V [Note 5]
Terminal resistor		R _T	-	(100)	-	Ω	Differential input

[Note]V_{CM}: Common mode voltage of LVDS driver.

[Note 1]

Input voltage sequences

$$(0.1)\text{ms} < t_1 \leq (20)\text{ms}$$

$$(10)\text{ms} < t_2$$

$$(0)\text{ms} < t_3$$

$$(0)\text{ms} < t_4$$

$$t_5 \geq (1)\text{s}$$

$$t_6 \geq (0)\text{s}$$

$$t_7 \geq (1)\text{s}$$

$$t_8 \geq (500)\text{ms}$$

$$t_9 \geq (1)\text{s}$$

Dip conditions for supply voltage

$$\text{a) } (6.5)\text{V} \leq V_{CC} < (10.8)\text{V}$$

$$t_d \leq (10)\text{ms}$$

$$\text{b) } V_{CC} < (6.5)\text{V}$$

Dip conditions for supply voltage is based on input voltage sequence.

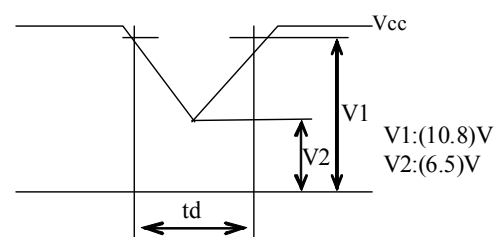
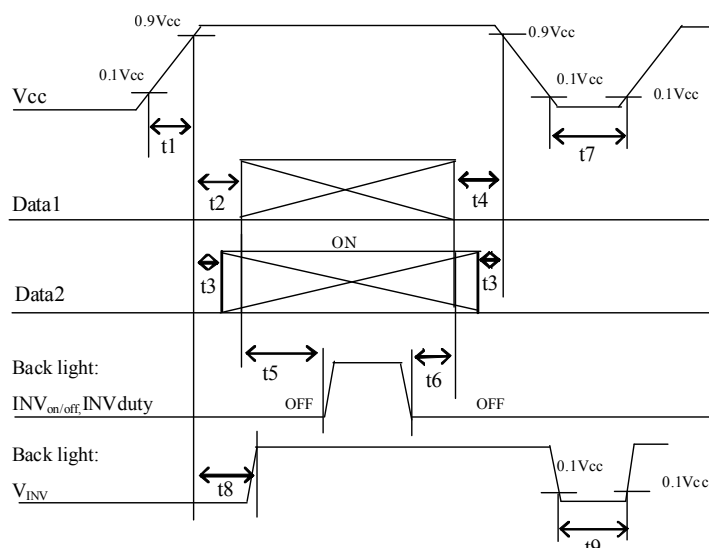

Data1: ACK±, AIN0±, AIN1±, AIN2±, AIN3±, BCK±, BIN0±, BIN1±, BIN2±, BIN3±

Data2: SELLVDS, Frame, O/Sset, Temp0,1,2

About the relation between data input and back light lighting, please base on the above-mentioned input sequence.

When back light is switched on before panel operation or after a panel operation stop, it may not display normally.

But this phenomenon is not based on change of an incoming signal, and does not give damage to a liquid crystal display.

[Note 2] Maximum current situation: white (RGB GS255)

Typical current situation: 256 gray-bar patterns. ($V_{cc} = +12.0V$)

The explanation of RGB gray scale is seen in section 8.

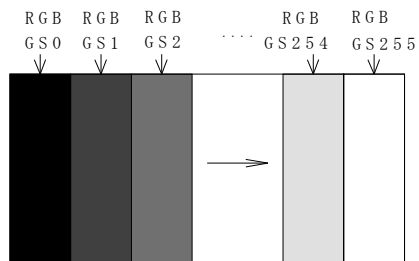

$V_{cc} = 12.0V$
 $CK = 74.25MHz$
 $TT = 29.6\mu s$

[Note 3] CPWB

[Note 4] $ACK\pm, BCK\pm, AIN0\pm, AIN1\pm, AIN2\pm, AIN3\pm, BIN0\pm, BIN1\pm, BIN2\pm, BIN3\pm$

[Note 5] SELLVDS, Frame, O/Sset, TEMP3, TEMP2, TEMP1

6-2. Inverter driving for back light

The back light system is direct type with 120CCFTs (Cold Cathode Fluorescent Tube).

Ta=25°C

Parameter	Symbol	Min.	Typ.	Max.	Unit	Remark	
+24V	Supply voltage	V _{INV}	23.0	24.0	25.0	V	INV _{duty} =100%, Von/off=3.3V 【Note 1,2】
	Current dissipation	I _{INV1}	-	(62)	(70)	A	V _{INV} = 24V INV _{duty} = 100%, INV _{on/off} =3.3V 【Note 1,2】
			-	(T.B.D.)	(T.B.D.)	A	V _{INV} = 24V INV _{duty} = 100%, INV _{on/off} =3.3V with cooling module 【Note 1,2】
		I _{INV2}	-	(50)	(58)	A	V _{INV} = 24V INV _{duty} = 100%, INV _{on/off} =3.3V 【Note 1,2】
			-	(65)	(75)	A	V _{INV} = 24V INV _{duty} = 100%, INV _{on/off} =3.3V with cooling module 【Note 1,2】
Permissible input ripple voltage	V _{RF}	-	-	300	mV _{p-p}	V _{INV} = +24V	
Input voltage (Low)	V _{ONL}	0	-	0.8	V	INV _{on/off} , INV _{duty} 【Note 1】	
Input voltage (High)	V _{ONH}	2.4	3.3	3.5	V		

【Note 1】 1) V_{INV}-turn-on condition

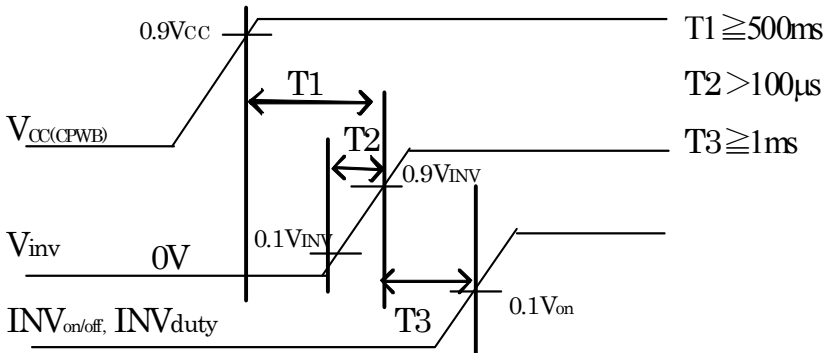

2) V_{INV}-turn-off condition

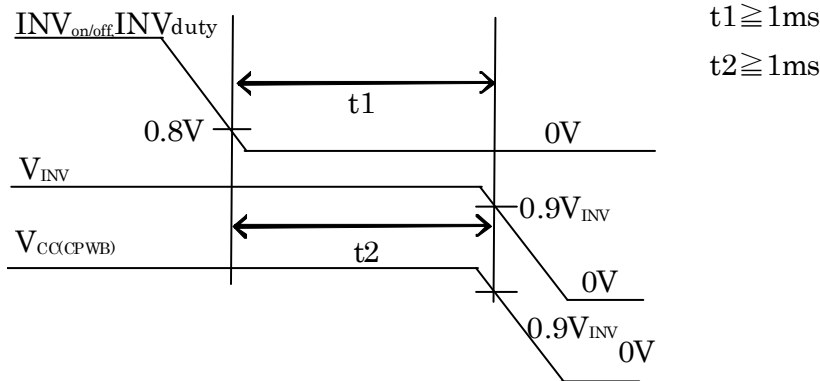

【Note 2】 Current dissipation I_{INV1} : Definition within 120 minutes after turn on. (*It doesn't include Rush current.)
 Current dissipation I_{INV2} : Definition more than 120 minutes after turn on.

【Note】 The inverter unit is working at the following drive frequency.
 *The lamp drive frequency: (31.4) kHz +/- (2.0)kHz
 *The burst Brightness control drive frequency:(165) Hz +/- (10) Hz

7. Timing characteristics of input signals

7-1. Timing characteristics

This LCD module is designed to be used in portrait position other than input signal.
 The definition of Input signal is based on landscape position. Therefore, please ensure to take it into account in designing your set.

Timing diagrams of input signal are shown in Fig.2.

60Hz-mode

Parameter	Symbol	Min.	Typ.	Max.	Unit	Remark
Clock	Frequency	1/Tc	(60)	74.25	80	MHz
	Clock-Data skew	-	(-250)	0	(+250)	ps
Data enable signal	Horizontal period	TT	(TBD)	1100	(TBF)	clock
			(TBD)	14.8	(TBD)	μs
	Horizontal period (High)	TTd	960	960	960	clock
	Horizontal period(Low)	TT-TTd	(80)	140	(445)	clock
	Vertical period	TY	16.5	16.67	(23.1)	ms
	Vertical period	TYd	1080	1080	1080	line
	Vertical period (Low)	TY-TYd	(31)	45	(TBD)	line
Frame	1/TY	(TBD)	60	60.6	Hz	

[Note] When vertical period is very long, flicker and etc. may occur.
 Please turn off the module after it shows the black screen.
 Please make sure that length of vertical period should become of an integral multiple of horizontal length of period. Otherwise, the screen may not display properly.

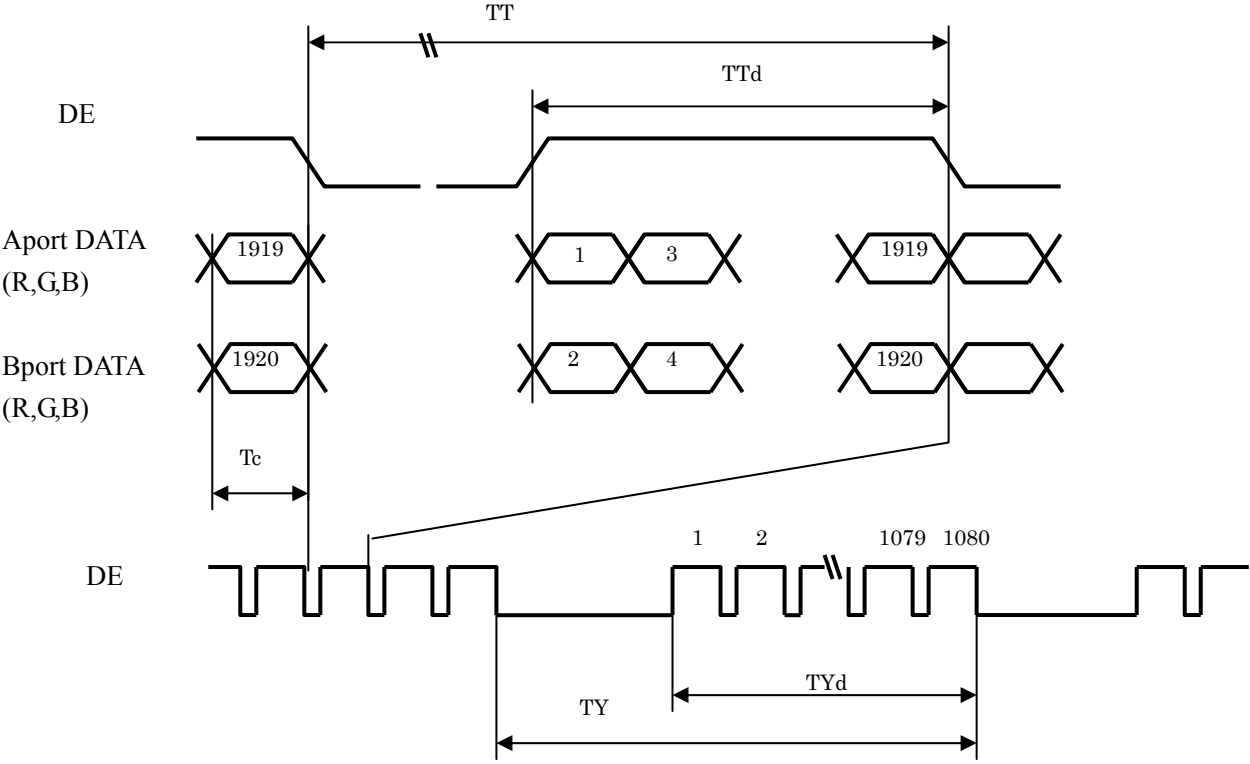
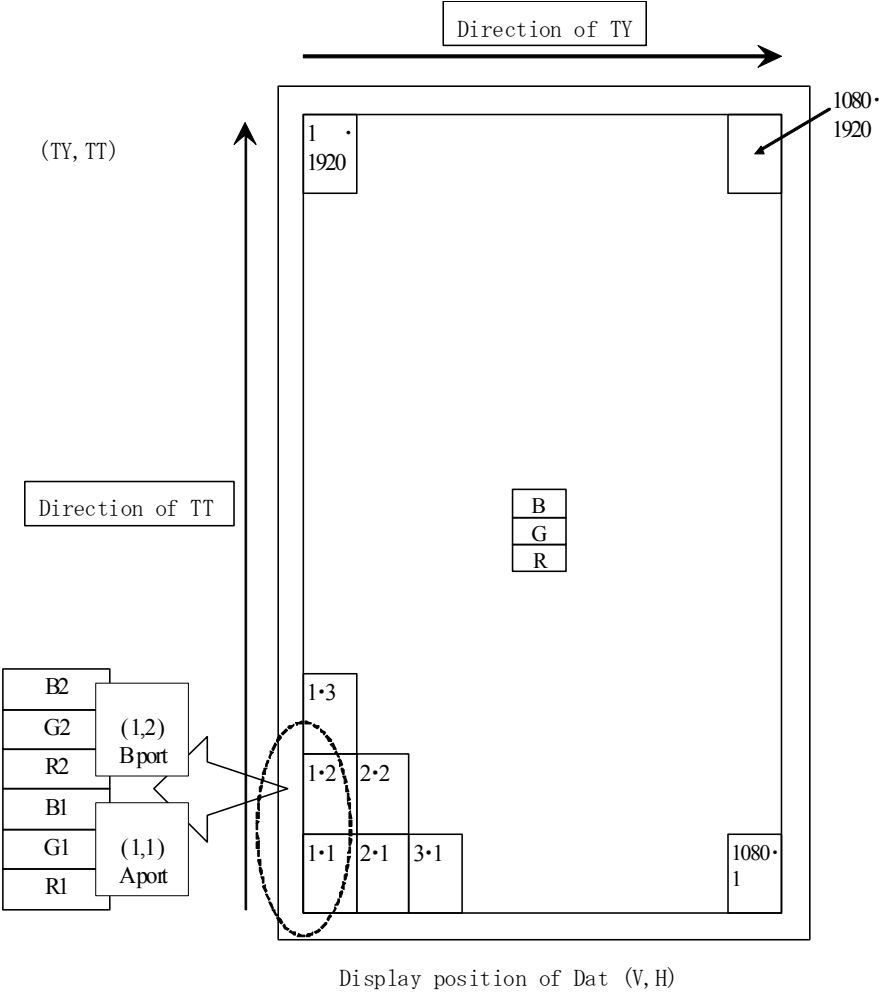

Fig.2 Timing characteristics of input signals

7-2. Input data signal and display position on the screen



8. Input Signal, Basic Display Colors and Gray Scale of Each Color

Colors & Gray scale	Data signal																										
	Gray Scale	R0	R1	R2	R3	R4	R5	R6	R7	G0	G1	G2	G3	G4	G5	G6	G7	B0	B1	B2	B3	B4	B5	B6	B7		
Basic Color	Black	—	0	0	0	0	0	0	0	0	0	0	0	0	0	0	0	0	0	0	0	0	0	0	0	0	
	Blue	—	0	0	0	0	0	0	0	0	0	0	0	0	0	0	0	0	1	1	1	1	1	1	1	1	
	Green	—	0	0	0	0	0	0	0	0	1	1	1	1	1	1	1	1	0	0	0	0	0	0	0	0	
	Cyan	—	0	0	0	0	0	0	0	0	1	1	1	1	1	1	1	1	1	1	1	1	1	1	1	1	
	Red	—	1	1	1	1	1	1	1	1	0	0	0	0	0	0	0	0	0	0	0	0	0	0	0	0	
	Magenta	—	1	1	1	1	1	1	1	1	0	0	0	0	0	0	0	0	1	1	1	1	1	1	1	1	
	Yellow	—	1	1	1	1	1	1	1	1	1	1	1	1	1	1	1	1	0	0	0	0	0	0	0	0	
	White	—	1	1	1	1	1	1	1	1	1	1	1	1	1	1	1	1	1	1	1	1	1	1	1	1	
Gray Scale of Red	Black	GS0	0	0	0	0	0	0	0	0	0	0	0	0	0	0	0	0	0	0	0	0	0	0	0	0	
	↑	GS1	1	0	0	0	0	0	0	0	0	0	0	0	0	0	0	0	0	0	0	0	0	0	0	0	
	Darker	GS2	0	1	0	0	0	0	0	0	0	0	0	0	0	0	0	0	0	0	0	0	0	0	0	0	
	↑	↓					↓							↓								↓					
	↓	↓					↓							↓								↓					
	Brighter	GS253	1	0	1	1	1	1	1	1	0	0	0	0	0	0	0	0	0	0	0	0	0	0	0	0	
	↓	GS254	0	1	1	1	1	1	1	1	0	0	0	0	0	0	0	0	0	0	0	0	0	0	0	0	
	Red	GS255	1	1	1	1	1	1	1	1	0	0	0	0	0	0	0	0	0	0	0	0	0	0	0	0	
Gray Scale of Green	Black	GS0	0	0	0	0	0	0	0	0	0	0	0	0	0	0	0	0	0	0	0	0	0	0	0	0	
	↑	GS1	0	0	0	0	0	0	0	0	1	0	0	0	0	0	0	0	0	0	0	0	0	0	0	0	
	Darker	GS2	0	0	0	0	0	0	0	0	0	1	0	0	0	0	0	0	0	0	0	0	0	0	0	0	
	↑	↓					↓							↓								↓					
	↓	↓					↓							↓								↓					
	Brighter	GS253	0	0	0	0	0	0	0	0	1	0	1	1	1	1	1	1	0	0	0	0	0	0	0	0	
	↓	GS254	0	0	0	0	0	0	0	0	0	1	1	1	1	1	1	1	0	0	0	0	0	0	0	0	
	Green	GS255	0	0	0	0	0	0	0	0	1	1	1	1	1	1	1	1	0	0	0	0	0	0	0	0	
Gray Scale of Blue	Black	GS0	0	0	0	0	0	0	0	0	0	0	0	0	0	0	0	0	0	0	0	0	0	0	0	0	
	↑	GS1	0	0	0	0	0	0	0	0	0	0	0	0	0	0	0	0	1	0	0	0	0	0	0	0	
	Darker	GS2	0	0	0	0	0	0	0	0	0	0	0	0	0	0	0	0	0	1	0	0	0	0	0	0	
	↑	↓					↓							↓								↓					
	↓	↓					↓							↓								↓					
	Brighter	GS253	0	0	0	0	0	0	0	0	0	0	0	0	0	0	0	0	1	0	1	1	1	1	1	1	
	↓	GS254	0	0	0	0	0	0	0	0	0	0	0	0	0	0	0	0	0	1	1	1	1	1	1	1	
	Blue	GS255	0	0	0	0	0	0	0	0	0	0	0	0	0	0	0	0	1	1	1	1	1	1	1	1	

0 : Low level voltage, 1 : High level voltage. *: Don't care

Each basic color can be displayed in 255 gray scales from 8 bit data signals. According to the combination of total 24 bit data signals, the 16-million-color display can be achieved on the screen.

9. Optical characteristics

$V_{CC} = 12.0V$, $V_{INV} = 24.0V$

Parameter		Symbol	Condition	Min.	Typ.	Max.	Unit	Remark	
Viewing angle range	Horizontal	θ_{21}	$CR \geq 10$ $T_a = 25^\circ C$	(80)	(88)	-	Deg.	[Note 1,4]	
		θ_{22}							
	Vertical	θ_{11}							
		θ_{12}							
Contrast ratio		CRn	(800)	(1500)	-		[Note 2,4] INV _{duty} =100%		
Response time		τ_{DRV}		(6)		ms	[Note 3,4,5] INV _{duty} =100%		
Chromaticity of white		x	$\theta = 0 \text{ deg}$ $T_a = 25^\circ C$	(0.257)	(0.287)	(0.317)	-	[Note 4] INV _{duty} =100%	
		y		(0.265)	(0.295)	(0.325)	-		
Chromaticity of red		x		(0.564)	(0.594)	(0.624)	-		
		y		(0.302)	(0.332)	(0.362)	-		
Chromaticity of green		x		(0.259)	(0.289)	(0.319)	-		
		y		(0.531)	(0.561)	(0.591)	-		
Chromaticity of blue		x		(0.117)	(0.147)	(0.177)	-		
		y		(0.066)	(0.096)	(0.126)	-		
Luminance of white		Y_{L1}		$\theta = 0 \text{ deg}$	(760)	(1000)		cd/m ²	INV _{duty} =100% [Note 4]
						(1500)			INV _{duty} =100% with cooling module [Note 4,7]
Luminance uniformity		δ_w		$\theta = 0 \text{ deg}$ $T_a = 25^\circ C$	-	-	(1.25)		[Note 6]

Measurement condition : Set the value of duty to maximum luminance of white.

*The measurement shall be executed (120) minutes after lighting at rating.

【Note】 The optical characteristics are measured using the following equipment.

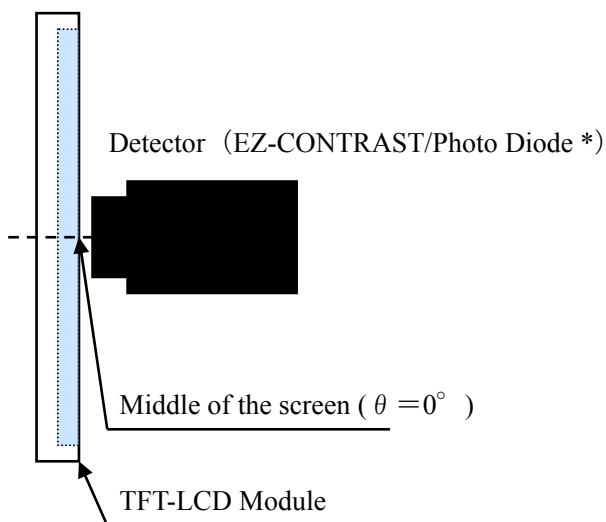

Fig.3-1 Measurement of viewing angle range and response time.

(Viewing angle range : EZ-CONTRAST/Photo Diode
Response time : Photo Diode)

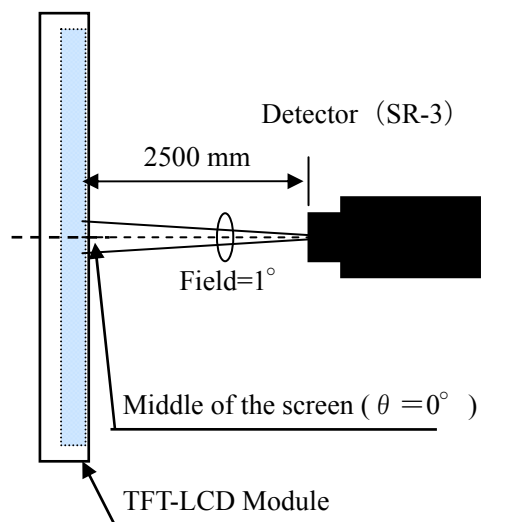
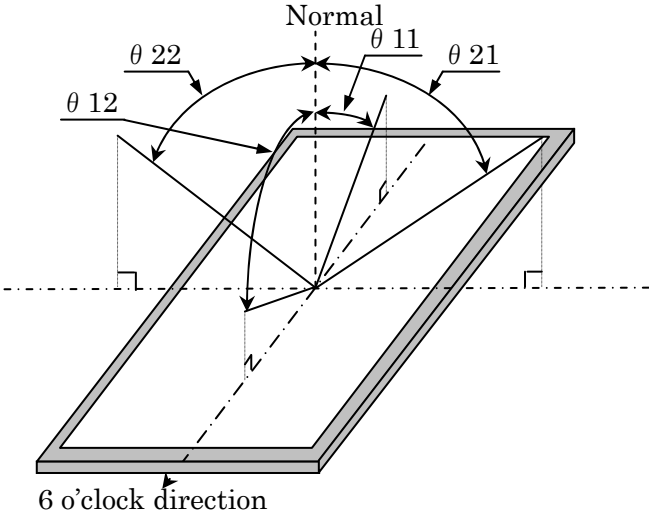

Fig.3-2 Measurement of Contrast, Luminance, Chromaticity .

[Note 1]Definitions of viewing angle range :



[Note 2]Definition of contrast ratio :

The contrast ratio is defined as the following.

$$\text{Contrast Ratio} = \frac{\text{Luminance (brightness) with all pixels white}}{\text{Luminance (brightness) with all pixels black}}$$

[Note 3]Definition of response time

3-1. Response time

The response time (τ_{Drv}) is defined as the following figure and shall be measured by switching the input signal for “five luminance ratio(0%, 25%, 50%, 75%, 100%)” and “five luminance ratio(0%, 25%, 50%, 75%, 100%)”.

	0%	25%	50%	75%	100%
0%		tr:0%-25%	tr:0%-50%	tr:0%-75%	tr:0%-100%
25%	Td:25%-0%		tr:25%-50%	tr:25%-75%	tr:25%-100%
50%	Td:50%-0%	td:50%-25%		tr:50%-75%	tr:50%-100%
75%	Td:75%-0%	td:75%-25%	td:75%-50%		tr:75%-100%
100%	td:100%-0%	td:100%-25%	td:100%-50%	td:100%-75%	

t*:x-y...response time from level of gray(x) to level of gray(y)

$$\tau_{Drv} = \Sigma(t*:x-y)/20$$

[Note 4]This shall be measured at center of the screen.

[Note 5] Response time is the value when O/S driving is used at typical input time value .

[Note 6]Definition of white uniformity ;

White uniformity is defined as the following with five measurements. (A~E)

$$\delta_w = \frac{\text{Maximum luminance of five points (brightness)}}{\text{Minimum luminance of five points (brightness)}}$$

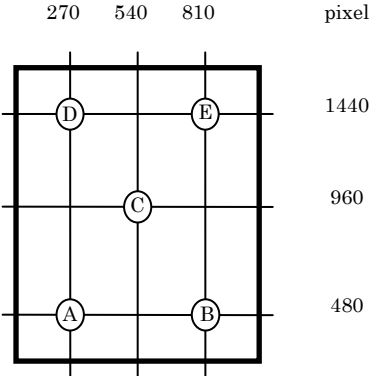

[Note 7] Fig.4 shows relation between the temperature of blowing air in the thermostatic chamber and luminance of white and relation between the temperature of blowing air in the thermostatic chamber and power.

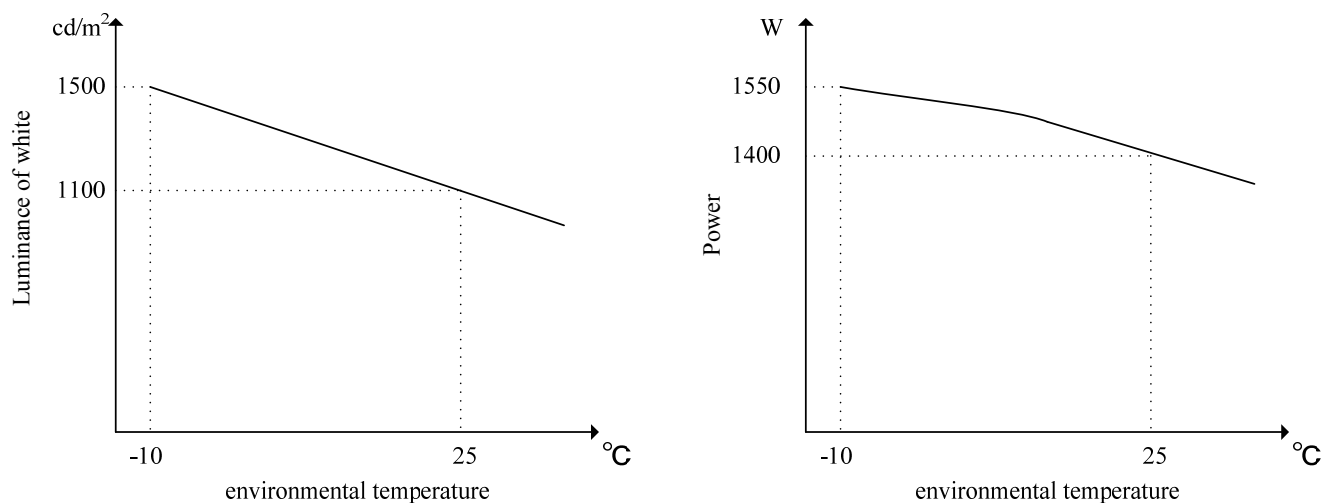

Fig.4 the temperature of blowing air in thermostatic chamber

10. Handling Precautions of the module

- Be sure to turn off the power supply when inserting or disconnecting the cable.
- This product is using the parts (inverter, CCFT etc), which generate the high voltage. Therefore, during operating, please don't touch these parts.
- Brightness control voltage is switched for "ON" and "OFF", as shown in Fig.5. Voltage difference generated by this switching, ΔV_{INV} , may affect a sound output, etc. when the power supply is shared between the inverter and its surrounding circuit. So, separate the power supply of the inverter circuit with the one of its surrounding circuit.

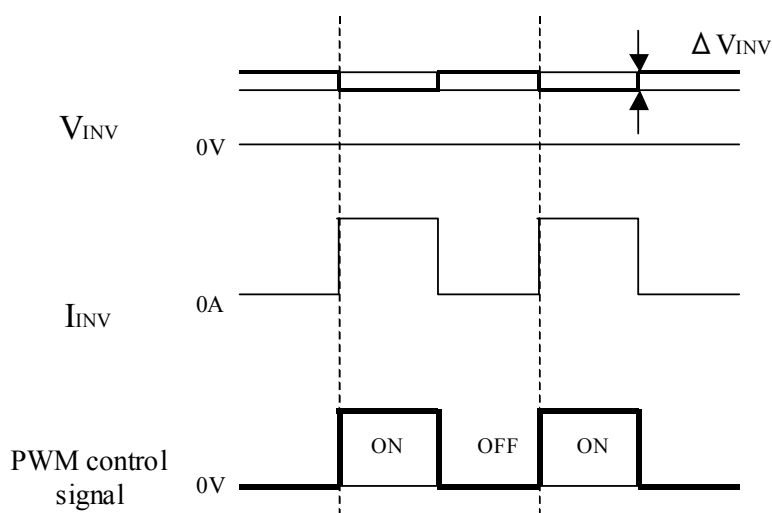

Fig.5 Brightness control voltage.

- Be sure to design the cabinet so that the module can be installed without any extra stress such as warp or twist.
- Since the front polarizer is easily damaged, pay attention not to scratch it.
- Since long contact with water may cause discoloration or spots, wipe off water drop immediately.

- g) When the panel surface is soiled, wipe it with absorbent cotton or other soft cloth.
- h) Since the panel is made of glass, it may break or crack if dropped or bumped on hard surface. Handle with care.
- i) Since CMOS LSI is used in this module, take care of static electricity and take the human earth into consideration when handling.
- j) The module has some printed circuit boards (PCBs) on the back side, take care to keep them from any stress or pressure when handling or installing the module; otherwise some of electronic parts on the PCBs may be damaged.
- k) Observe all other precautionary requirements in handling components.
- l) When some pressure is added onto the module from rear side constantly, it causes display non-uniformity issue, functional defect, etc.. So, please avoid such design.
- m) When giving a touch to the panel at power on supply, it may cause some kinds of degradation. In that case, once turn off the power supply, and turn on after several seconds again, and that is disappear.
- n) When handling LCD modules and assembling them into cabinets, please be noted that long-term storage in the environment of oxidization or deoxidization gas and the use of such materials as reagent, solvent, adhesive, resin, etc. which generate these gasses, may cause corrosion and discoloration of the LCD modules.
- o) Lamps of the backlight are placed horizontally to the short side of LCD module. The lifetime of the backlight shortens if the module is used in transverse.
- p) Make sure that the LCD module is operated within specified temperature and humidity. Measures against dust, water, vibration, and heat radiation, etc. are required at the cabinet or equipment side. And image retention may occur if same fixed pattern is displayed for a long time. In some cases, it may not disappear. It is recommended to use moving picture periodically. After long-term static display, periodical power-off or screen saver is needed. For screen saver, moving picture or black pattern is strongly recommended. Avoid combination of background and image with large different luminance. Please consider the design and operating environment.
- q) Ultra-violet ray filter is necessary for outdoor operation.
- r) Operation for 24 hours a day is NOT recommended.
- s) Well-ventilated place is recommended to set up Information Display system.
- t) Execute it at 0°C or above when you light the module. It doesn't light when starting lighting at a temperature that is lower than 0°C
- u) If you control the temperature of the ambient air or the module, please uniformize the temperature of the module.

11. Packing form

- a) Piling number of cartons: (1) maximum (do not pile up.)
- b) Packing quantity in one carton: (4) pcs.
- c) Carton size: (1230) (W) × (1090) (D) × (2134) (H)
- d) Total mass of one carton filled with full modules: (TBD)kg
- e) Packing Form are shown in Fig 5. (TBD)

12. Reliability test item(TBD) *Only as for the module.

No.	Test item	Condition
1	High temperature storage test	Ta=60°C 240h
2	Low temperature storage test	Ta=-20°C 240h
3	High temperature and high humidity operation test	Ta=(TBD) °C ; 95%RH 240h (No condensation)
4	High temperature operation test	Ta=(TBD)°C 240h
5	Low temperature operation test	Ta=(-10)°C 240h
6	Vibration test* (non-operation)	Frequency: 10~57Hz/Vibration width (one side): 0.075mm : 58~500Hz/Acceleration: 9.8 m/s ² Sweep time: 11 minutes Test period: 1.5 hours (0.5h for each direction of X, Y, Z)
7	Shock test* (non-operation)	Maximum acceleration: 294m/s ² Pulse width: 11ms, sinusoidal half wave Direction: (+/-Y), once for each direction.
8	ESD	At the following conditions, it is a thing without incorrect operation and destruction. (1)Non-operation: Contact electric discharge +/-10kV Non-contact electric discharge +/-20kV (2)Operation Contact electric discharge +/-8kV Non-contact electric discharge +/-15kV Conditions: 150pF, 330ohm

*Under a designated fixation method(TBD).

【Result evaluation criteria】

Under the display quality test condition with normal operation state, there shall be no change, which may affect practical display function.

13. Others

1) Lot No. Label (T.B.D.)

The label that displays SHARP,product model(LK816D3LA1x),a product number is stuck on the back of the module.



How to express Lot No.

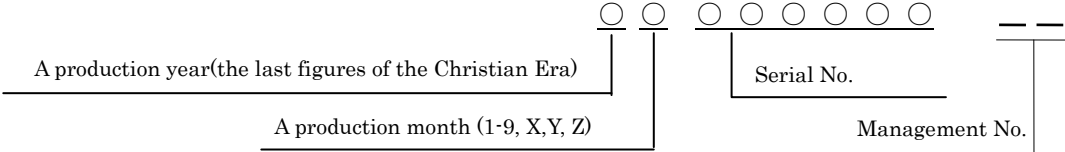

2) Packing Label

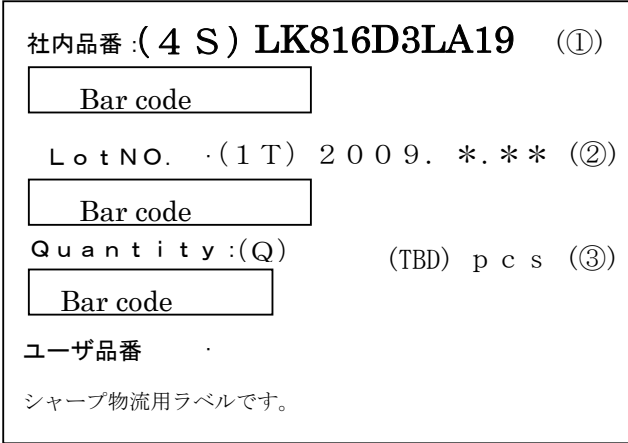

- ① Management No. (LK816D3LA19)
- ② Lot No. (Date)
- ③ Quantity

- 3) Adjusting volume have been set optimally before shipment, so do not change any adjusted value. If adjusted value is changed, the specification may not be satisfied.
- 4) Disassembling the module can cause permanent damage and should be strictly avoided.
- 5) Please be careful since image retention may occur when a fixed pattern is displayed for a long time.
- 6) Cold cathode fluorescent lamp in LCD PANEL contains a small amount of mercury. Please follow local ordinances or regulations for disposal. It is displaying the label in the module back.

COLD CATHODE FLUORESCENT LAMP IN LCD PANEL
 CONTAINS A SMALL AMOUNT OF MERCURY, PLEASE FOLLOW
 LOCAL ORDINANCES OR REGULATION FOR DISPOSAL
 当該液晶ディスプレイパネルは蛍光管が組み込まれていますので、地方自治体の条例、または、規則に従って廃棄ください。

- 7) Lead-free soldering is applied.
- 8) This module is corresponded to RoHS
- 9) The chemical compound, which causes the destruction of ozone layer, is not being used.
- 10) Rust on the module is not taken up a problem.
- 11) Appearance quality and standard are referred to the outgoing incoming inspections.

14. Carton storage condition

Temperature	0°C to 40°C
Humidity	95%RH or less
Reference condition	: 20°C to 35°C , 85%RH or less (summer) : 5°C to 15°C , 85%RH or less (winter) • the total storage time (40°C,95%RH) : 240h or less
Sunlight	Be sure to shelter a product from the direct sunlight.
Atmosphere	Harmful gas, such as acid and alkali which bites electronic components and/or wires must not be detected.
Notes	Be sure to put cartons on palette or base, don't put it on floor, and store them with removing from wall Please take care of ventilation in storehouse and around cartons, and control changing temperature is within limits of natural environment Please keep LCD module in Portrait position. (The long side of LCD module is placed vertically)
Storage life	1 year

