

mass integrated

global part distribution • product lifecycle partner
excess inventory management • value-ad service provider



Data sheet provided by Mass Integrated

massintegrated.com • displayalliance.com

Please call +1.978.465.6190
Email: sales@massintegrated.com



ISO 9001: 2008

Mass Integrated complies with all DMCA takedown notices. Please send a formal DMCA Takedown Notice to Mass Integrated Systems, Inc. • 18 Henry Graf Jr. Road, Unit 1 • Newburyport, MA 01950.

Product Specification

SPECIFICATION For APPROVAL

- Preliminary Specification
 Final Specification

Title	14.1" XGA TFT LCD
--------------	--------------------------

BUYER NAME	
MODEL NAME	

SUPPLIER	LG Electronics Inc.
MODEL NAME	LP141X3

SIGNATURE	DATE
Please return 1 copy for our confirmation with your signature and comments.	

SIGNATURE	DATE
APPROVED BY	
REVIEWED BY	
PREPARED BY	
Product Engineering Dept. LCD DIVISION LG Electronics, Inc.	

Product Specification
TABLE of CONTENTS

NO.	ITEM	Page
-	COVER	1/19
-	TABLE of CONTENTS	2/19
-	RECORD of REVISION	3/19
1.	GENERAL DESCRIPTION	4/19
2.	MAXIMUM RATINGS	5/19
3.	ELECTRICAL SPECIFICATIONS	5/19
4.	OPTICAL SPECIFICATIONS	6/19
5.	INTERFACE CONNECTIONS	7/19
6.	SIGNAL TIMING SPECIFICATIONS	9/19
7.	SIGNAL TIMING WAVE FORMS	10/19
8.	COLOR INPUT DATA REFERENCE	11/19
9.	POWER SEQUENCE	12/19
10.	MECHANICAL CHARACTERISTICS	13/19
11.	HANDLING PRECAUTIONS	15/19
-	APPENDIX	18/19

Product Specification

Record of Revision

DATE AND VERSION	DESCRIPTION

Product Specification

1. General Description

The LG Electronics model LP141X3 LCD is a Color Active Matrix Liquid Crystal Display with an integral Cold Cathode Fluorescent Tube(CCFT) back light system. The matrix employs a-Si Thin Film Transistor as the active element. It is a transmissive type display operating in the normally white mode. This TFT-LCD has a 14.1 inch diagonally measured active display area with XGA resolution(768 vertical by 1024 horizontal pixel array). Each pixel is divided into Red, Green and Blue sub-pixels or dots which are arranged in vertical stripes. Gray scale or the brightness of the sub-pixel color is determined with a 6-bit gray scale signal for each dot, thus, presenting a pallet of more than 262,144 colors.

The LP141X3 LCD is intended to support applications where low power consumption, weight and thickness are critical factors and graphic displays are important. In combination with the vertical arrangement of the sub-pixels, the LP141X3 characteristics provide an excellent flat panel display for office automation products such as portable computers.

This LCM has SN75LVDS86 LVDS Interface supplied by TI Japan.

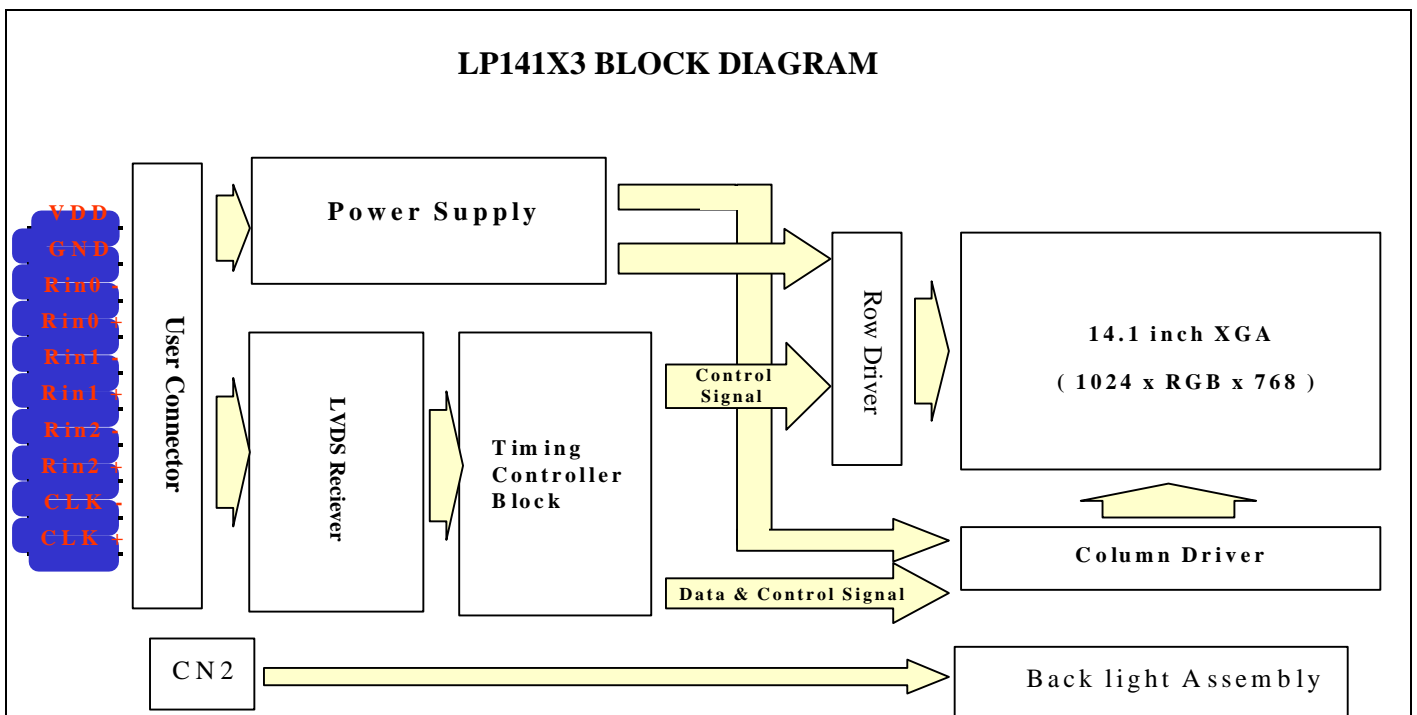

General Display Characteristics

The following are general feature of the model LP141X3 LCD;

Active display area	14.1 inch diagonal
Outsize dimensions	298.5 W x 227.0H x 7.5 D mm Typ.
Pixel pitch	0.28 mm x 0.28 mm
Pixel format	1024 horiz. By 768 vert. pixels
Color depth	RGB stripe arrangement
Display operating mode	6-bit
Surface treatment	transmissive mode, normally white
	hard coating(3H),
	anti-glare treatment of the front polarizer

Product Specification

2. Maximum Ratings

The following are maximum values which, if exceeded, may cause faulty operation or damage to the unit.

Table 1 ABSOLUTE MAXIMUM RATINGS

Parameter	symbol	Values		Units	Notes
		Min.	Max.		
Power Input Voltage	V _{DD}	0	3.63	Vdc	at 25 C
Logic Input Voltage	V _{L/H}	-0.3	V _{DD} +0.3	Vdc	at 25 C
Operating Temperature	T _{OP}	0	+40	C	1
Storage Temperature	T _{ST}	-20	+60	C	1

Note: 1. The Relative Humidity must not exceed **80%** non-condensing at temperatures of 40 C or less.

At temperatures greater than 40 C , the wet bulb temperature must not exceed 39 C .

At low temperature the brightness of CCFL drop and the life time of CCFL become to be short.

2. Under no condition should the unit be exposed to corrosive chemicals.

3. Electrical Specifications

The LP141X3 requires two power inputs. One is employed to power the LCD electronics and to derive the voltages to drive the TFT array and liquid crystal. The second input which powers the backlight CCFT, is typically generated by an inverter. The inverter is an external unit to the LCD.

Table 2 ELECTRICAL CHARACTERISTICS:

Parameter	Symbol	Values			Units	Notes
		Min.	Typ.	Max.		
MODULE:						
Power Supply Input Voltage	V _{DD}	3.0	3.3	3.6	Vdc	
Power Supply Input Current	I _{DD}	-	400	640	mA	1,2
Ripple/Noise	-	-	-	60	mV	
Differential input voltage, High	V _{IH}	-	-	100	mV	2
for receiver threshold, Low	V _{IL}	-100	-	-	mV	2
BACKLIGHT						
Backlight Input voltage	V _{BL}	-	755	-	V _{RMS}	3
Backlight Current	I _{BL}	2.0	3.5	5.0	mA	
Lamp Kick-Off Voltage				1200	V _{RMS}	25+-2C
Operating Frequency	F _{BL}	(50)	55	(60)	KHz	
CCFL Life Time		10,000			Hours	@ I _{BL} =5mA

Notes: 1. The current draw and power consumption specified is for 3.3 Vdc at 25C.

Typical value is measured when displaying mosaic(pixel checkerboard) screen.

2. Maximum power situation measured with alternating white-black line pattern.

LVDS common mode voltage, VCM=1.2V

3. The backlight power consumption shown above does not include loss of external inverter.

Product Specification

4. Optical Specifications

Optical characteristics are determined after the unit has been 'ON' and stable for approximately 30 minutes in a dark environment at 25C. The values specified are at an approximate distance 50cm from the LCD surface at a viewing angle of Φ and θ equal to 0°.

Appendix A presents additional information concerning the specified characteristics.

Table 2 OPTICAL CHARACTERISTICS

Parameter		Symbol	Values			Units	Notes
			Min.	Typ.	Max.		
Contrast Ratio		CR	120	150	-	-	1
White Surface Brightness	IBL=5.0mA	SB _{WH}	120	130	-	cd/m ²	2
Brightness Variation		SB _V	-	-	1.5		3
Response Time	Rise Time	Tr _R	-	20	40	msec	
	Decay Time	Tr _D	-	30	50	msec	
Color Coordinates	RED	x	0.558	0.588	0.618	-	6
		y	0.310	0.340	0.370	-	6
	GREEN	x	0.280	0.310	0.340	-	6
		y	0.511	0.541	0.571	-	6
	BLUE	x	0.120	0.150	0.180	-	6
		y	0.104	0.134	0.164	-	6
	WHITE	x	0.295	0.325	0.335	-	6
		y	0.311	0.341	0.371	-	6
Viewing Angle (CR>10:1)	x axis, right (=0)		40			degree	5
	x axis, left(=180)		40			degree	5
	y axis, up(=90)		10			degree	5
	y axis, down(=270)		30			degree	5

Notes 1. Contrast Ratio (CR) is defined mathematically as:

$$\frac{\text{(Surface Brightness with all white pixels)}}{\text{(Surface Brightness with all black pixels)}}$$

- Surface brightness is 5 spot average of measurement across the LCD surface 50cm from the surface with all pixels displaying white. For more information see Appendix A.
- The variation in surface brightness, SB_V is determined by measuring B_{ON} at each test position 1 through 13, and then dividing the maximum B_{ON} by the minimum B_{ON}.

$$\frac{\text{Maximum (B}_{ON1}, \text{B}_{ON2}, \dots, \text{B}_{ON13})}}{\text{Minimum (B}_{ON1}, \text{B}_{ON2}, \dots, \text{B}_{ON13})}}$$

- Response time is the time required for the display to transition from white to black (Rise Time, Tr_R) and from black to white (Decay Time, Tr_D). For additional information see Appendix A.
- Viewing angle is the angle at which the contrast ratio is greater than 10. The angles are determined for the horizontal or x axis and the vertical or y axis with respect to the z axis which is normal to the LCD surface. For more information see Appendix A.
- Color Coordinates can be changed according to color filter. (In case of changing color filter, we will tell our customer.)

Product Specification

5. Interface Connections

This LCD employs two interface connections, a 20 pin connector is used for the module electronics and a three pin connector is used for the integral backlight system.

The electronics interface connector is a model FI-SEB-20P-HF, manufactured by JAE.

The pin configuration for the connector is shown in the table below.

Table 3 MODULE CONNECTOR PIN CONFIGURATION

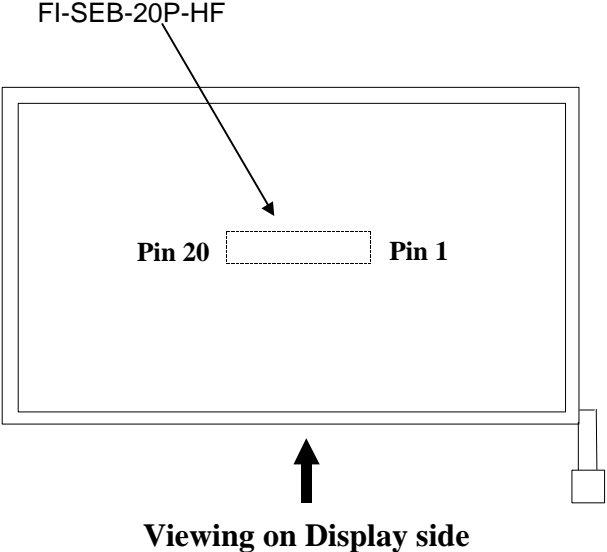
Pin	Symbol	Description	Notes
1	VDD	Power supply, 3.3V	
2	VDD	Power supply, 3.3V	
3	GND	Ground	
4	GND	Ground	
5	Rin0 -	Receiver signal (-)	
6	Rin0 +	Receiver signal (+)	
7	GND	Ground	
8	Rin1 -	Receiver signal (-)	
9	Rin1 +	Receiver signal (+)	
10	GND	Ground	
11	Rin2 -	Receiver signal (-)	
12	Rin2 +	Receiver signal (+)	
13	GND	Ground	
14	CLK -	Clock signal (-)	
15	CLK +	Clock signal (+)	
16	GND	Ground	
17	NC	Reserved	
18	NC	Reserved	
19	GND	Ground	
20	GND	Ground	

- Notes:
1. All GND(ground) pins should be connected together and to GND which should also be connected to the LCD's metal frame.
 2. All V_{DD}(power input) pins should be connected together.

Product Specification

Interface Connections (cont' d)

The backlight interface connector is a model BHSR-02VS-1, manufactured by JST. The mating connector part number is SM02B-BHSS-1-TB or equivalent. The pin configuration for the connector is shown in the table below.

Table 4 BACKLIGHT CONNECTOR PIN CONFIGURATION

Pin	Symbol	Description	Notes
1	HV	Lamp power input	1
2	LV	Ground	2

Notes: 1. The input power terminal is white

2. The ground terminal is black.

Product Specification

6. Signal Timing Specification

6.1. Interface Signal Timing

Refers to SN75LVDS86 data sheet supplied by TI(Texas Instrument).

6.2. Signal timing between SN75LVDS86 and LCD controller(ASIC).

This is the signal timing required at the input of the control ASIC concerned with LVDS as a Flat Link or equivalent. All of the interface signal timing should be satisfied with the following specifications based on the VESA timing guideline (1024 x 768 @60Hz) for it's proper operation.

LP141X3 with LVDS transmitter recommend to connect to the Display Enable, Horizontal sync, Vertical sync, Clock signal from Video signal controller to input of Transmitter simultaneously.

ITEM		Symbol	Value			Units	Notes
			Min.	Typ.	Max.		
DCLK	Period	Tclk	-	65	-	Mhz	1
	Rise Time	Trck	1.6	2.0	2.3	ns	
	Fall Time	Tfclk	0.9	1.1	-	ns	
	Duty	kdr	0.45	0.5	0.55	-	
DTMG	Set up Time	Tsde	4	-	-	ns	
	Hold Time	Thde	5	-	-	ns	
	Horizontal Period	Thp	1208	1344	1364	Tclk	
	Horizontal Blank Period	Twhp	315	320	325	Tclk	
	Vertical Period	Tvp	33	38	44	Thp	
	Vertical Blank Period	Twvp	801	806	812	Thp	
Hsync	Hsync Back Porch	Hbp	160	160	160	Tclk	
	Hsync Front Porch	Hfp	20	24	45	Tclk	
	Horizontal Active Period	Twha	1024	1024	1024	Tclk	
Vsync	Vsync Back Porch	Vbp	29	29	29	Thp	
	Vsync Front Porch	Vfp	1	3	6	Thp	
	Vertical Active Period	Twva	768	768	768	Thp	
DATA	Set up Time	Tsd	3.5	4	-	ns	for DCLK
	Hold Time	Thd	3.5	4	-	ns	
	Rise Time	Trd	3.2	3.9	4.5	ns	
	Fall Time	Tfd	1.4	1.7	2.1	ns	

Note : 1. Dclk values are required for LVDS applications

Dclk jitter requirement for transmitter : max. 2.0nsec

LVDS used for Rx : SN75LVDS86 or equivalent (Tx : SN75LVDS84 or equivalent)

Product Specification

7. Signal Timing Wave Forms

7.1. Interface Signal Timing Wave Forms refers to SN75LVDS86 data sheet.

7.2. Timing wave forms between SN75LVDS86 and LCD controller(ASIC).

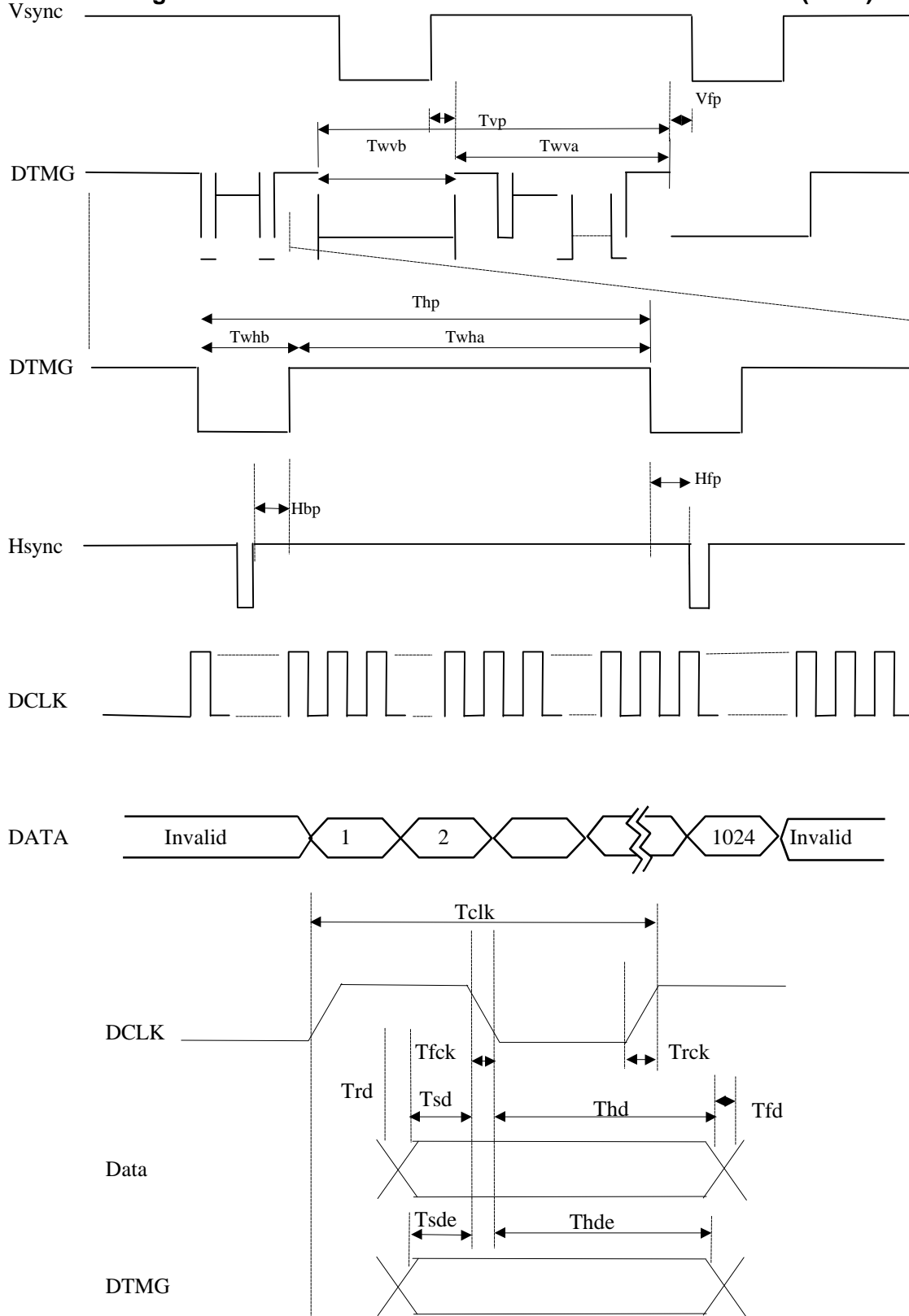

Product Specification

8. Color Input Data Reference

The brightness of each primary color (red, green and blue) is based on the 6-bit gray scale data input for the color; the higher the binary input, the brighter the color. The table below provides a reference for color versus data input.

Table 5 COLOR DATA REFERENCE

Color		Input Color Data																	
		Red						Green						Blue					
		R5	R4	R3	R2	R1	R0	G5	G4	G3	G2	G1	G0	B5	B4	B3	B2	B1	B0
Basic Colors	Black	0	0	0	0	0	0	0	0	0	0	0	0	0	0	0	0	0	0
	Red(00)	1	1	1	1	1	1	0	0	0	0	0	0	0	0	0	0	0	0
	Green(00)	0	0	0	0	0	0	1	1	1	1	1	1	0	0	0	0	0	0
	Blue(00)	0	0	0	0	0	0	0	0	0	0	0	0	1	1	1	1	1	1
	Cyan	0	0	0	0	0	0	1	1	1	1	1	1	1	1	1	1	1	1
	Magenta	1	1	1	1	1	1	0	0	0	0	0	0	1	1	1	1	1	1
	Yellow	1	1	1	1	1	1	1	1	1	1	1	1	0	0	0	0	0	0
	White	1	1	1	1	1	1	1	1	1	1	1	1	1	1	1	1	1	1
Red	Red(63) Black	0	0	0	0	0	0	0	0	0	0	0	0	0	0	0	0	0	0
	Red(62)	0	0	0	0	0	1	0	0	0	0	0	0	0	0	0	0	0	0
	Red(61)	0	0	0	0	1	0	0	0	0	0	0	0	0	0	0	0	0	0
	:	:	:	:	:	:	0	0	0	0	0	0	0	0	0	0	0	0	
	Red(02)	1	1	1	1	0	1	0	0	0	0	0	0	0	0	0	0	0	0
	Red(01)	1	1	1	1	1	0	0	0	0	0	0	0	0	0	0	0	0	0
	Red(00)	1	1	1	1	1	1	0	0	0	0	0	0	0	0	0	0	0	0
Green	Green(63) Black	0	0	0	0	0	0	0	0	0	0	0	0	0	0	0	0	0	0
	Green(62)	0	0	0	0	0	0	0	0	0	0	1	0	0	0	0	0	0	
	Green(61)	0	0	0	0	0	0	0	0	0	0	1	0	0	0	0	0	0	
	:	:	:	:	:	:	0	0	0	0	0	0	0	0	0	0	0	0	
	Green(02)	0	0	0	0	0	0	1	1	1	1	0	1	0	0	0	0	0	
	Green(01)	0	0	0	0	0	0	1	1	1	1	1	0	0	0	0	0	0	
	Green(00)	0	0	0	0	0	0	1	1	1	1	1	1	0	0	0	0	0	
Blue	Blue(63) Black	0	0	0	0	0	0	0	0	0	0	0	0	0	0	0	0	0	0
	Blue(62)	0	0	0	0	0	0	0	0	0	0	0	0	0	0	0	0	0	1
	Blue(61)	0	0	0	0	0	0	0	0	0	0	0	0	0	0	0	0	1	0
	:	:	:	:	:	:	0	0	0	0	0	0	;	:	:	:	:	:	
	Blue(02)	0	0	0	0	0	0	0	0	0	0	0	0	1	1	1	1	0	1
	Blue(01)	0	0	0	0	0	0	0	0	0	0	0	0	1	1	1	1	1	0
	Blue(00)	0	0	0	0	0	0	0	0	0	0	0	0	1	1	1	1	1	1

Product Specification

9. Power Sequence

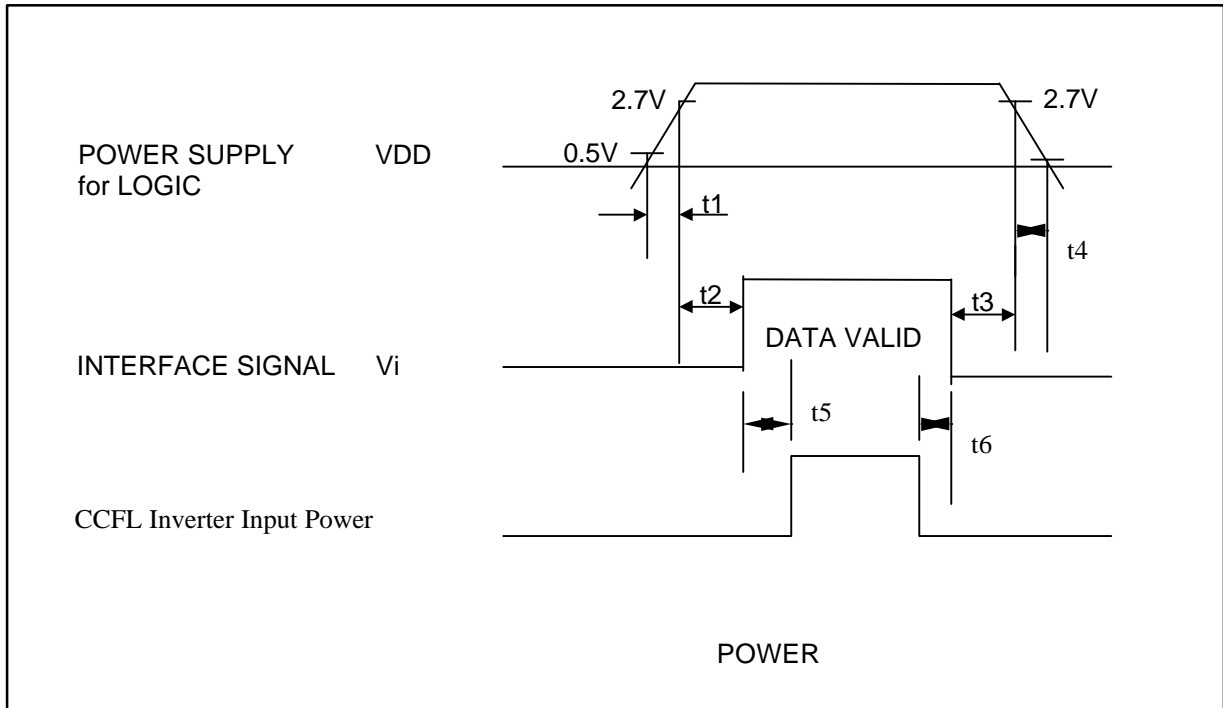

$t1 \leq 5\text{msec}$, $0 < t2 \leq 50\text{msec}$, $0 < t3 \leq 50\text{msec}$, $t4 \leq 5\text{msec}$, $1 < t5 \leq 2 \text{ sec}$, $1 < t6 \leq 2 \text{ sec}$

* Set $0 \text{ Volt} < Vi(t) = < V_{DD}(t)$

Here $Vi(t)$, $V_{DD}(t)$ indicate the transitive state of Vi , V_{DD} when power supply is turned ON or OFF

- Notes :
1. Please avoid floating state of interface signal at invalid period.
 2. When the interface signal is invalid, be sure to pull down the power supply for LCD V_{DD} to 0V.

Product Specification

10. Mechanical Characteristics

The chart below provides general mechanical characteristics for the model LP141X3 LCD. The surface of the LCD has an anti-glare coating to minimize reflection and a 2H hard coating to reduce scratching. In addition, the figure below is a detailed mechanical drawing of the LCD. Note that dimension are given for reference purposes only.

Outside dimensions	Width	298.5 mm typ.
	Height	227.0 mm typ.
	Thickness	7.5 mm typ.
Active Display area	Width	285.7 mm
	Height	214.3 mm
	Diagonal	14.1 inch
Weight		625g typ. 635g max.

Product Specification

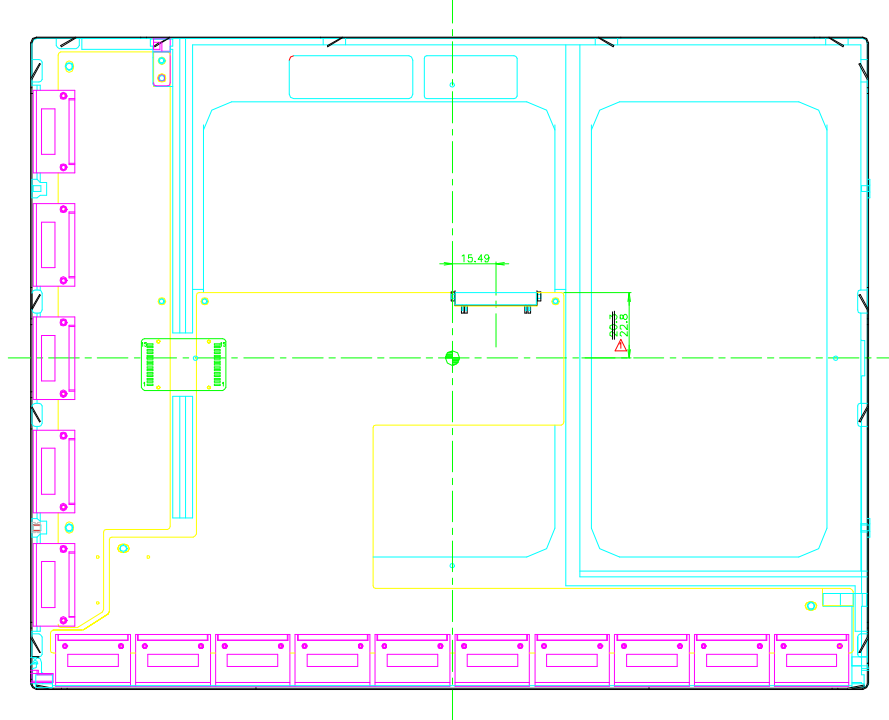

11. Handling Precautions

Please pay attention to the followings when you use this TFT/LCD module with Back-light unit.

11.1.MOUNTING PRECAUTION

- 1) You must mount Module using mounting holes arranged in 4 corners.
Be sure to turn off the power when connecting or disconnecting the circuit.
- 2) Note that the polarizers are easily damaged. Pay attention not to scratch or press this surface with any hard object.
- 3) When the LCD surface become dirty, please wipe it off with a soft material.
(ie.cotton ball)
- 4) Protect the module from the ESD as it may damage the electronic circuit (C-MOS).
Make certain that treatment person's body are grounded thru wrist bend.
- 5) Do not disassemble the module and be careful not to incur a mechanical shock that might occur during installation. It may cause permanent damage.
- 6) Do not leave the module in high temperatures, Particularly in areas of high humidity for a long time.

Product Specification

- 7) The module not be expose to the direct sunlight.

- 8) Avoid contact with water as it may a short circuit within the module.

11.2 OPERATING PRECAUTION

- 1) The spike noise causes the mis-operation of circuits.
Be lower the spike noise as follows :
VDD= \pm 200mV, V1= \pm 200mV(Over and under shoot voltage.)
- 2) Response time depends on the temperature. (In lower temperature, it becomes longer.)
- 3) Brightness depends on the temperature. (In lower temperature, it becomes lower.)
And in lower temperature, response time (Required time that brightness is stable after turn on)becomes longer.
- 4) Be careful for condensation at suddern temperature change. Condensation make damage to polarizer or electrical contact part. And after fading condensation, smear or spot will occur.
- 5) When fixed pattern are displayed at long times, remnant image is likely to occur.
- 6) Module has high frequency circuit. If you need to shield the electromagnetic noise.
Please do in yours.
- 7) When Back-light unit is operating, it sounds.
If you need to shield the noise, please do in yours.

11.3 ELECTROSTATIC DISCHARGE CONTROL

Since module is composed with electronic circuit, it is not strong to electrostatic discharge. Make certain that treatment persons are connected to ground through list band etc.. And don' t touch I/F pin directly.

11.4 PRECAUTION FOR STRONG LIGHT EXPOSURE.

Strong light exposure causes degradation of polarizer and color filter.

Product Specification**11.5 STORAGE**

When storing module as spares for long time, the following precautions are necessary.

- 1) Store them in a dark place : do not expose them to sunlight or fluorescent light. Keep the temperature between 5 and 35 at normal humidity.
- 2) The polarizer surface should not come in contact with any other object. It is recommended that they be stored in the container in which they were shipped.

11.6 HANDLING PRECAUTIONS FOR PROTECTION FILM

- 1) When the protection film is peeled off, static electricity is generated between the film and the polarizer. This film should be peeled off slowly and carefully by people who are electrically grounded and with well ion-blown equipment or in such a condition. etc.
- 2) The protection film is attached the polarizer with a small amount of glue. If some stress is applied to rub the protection film against the polarizer during the time you peel off the film, the glue is apt to remain more on the polarizer. So please carefully peel off the protection film without rubbing it against the polarizer.
- 3) When the module with protection film attached is stored for long time, sometimes there remains a very small amount of glue still on the polarizer after the protection film is peeled off.
Please refrain from storing the module at the high temperature and high humidity for glue is apt to remain in these condition.
- 4) The glue may be taken for the modules failure, but you can remove the glue easily. When the glue remains on the polarizer surface or its vestige is recognized, please wipe them off with absorbent cotton waste or other soft material like chamois soaked with Normal-hexane.

11.7 SAFETY

- 1) If module is broken, be careful to handle not to injure. (TFT/LCD and lamp are made of glass)
Please wash hands sufficiently when you touch the liquid crystal coming out from broken LCDs.
- 2) As it is possible for PCB or other electronic parts of module to small to smoke and to take fire because of the short circuit. Please design the circuit of your instrument not to flow the electric current to TFT/LCD module more than 500mA. (by apply the fuse for example)
- 3) As Back-light unit has high voltage circuit internal, do not open the case and do not insert foreign materials in the case.

Product Specification

A-1 BRIGHTNESS

<measuring point>

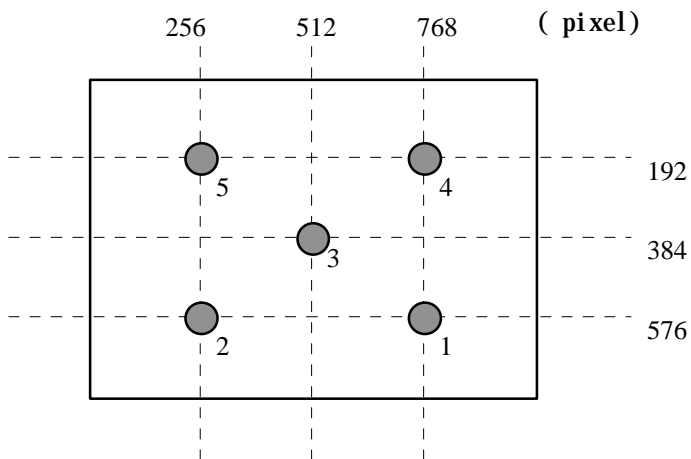

A-2. 13 SPOT LUMINANCE VARIATION MEASUREMENT LOCATIONS

Product Specification

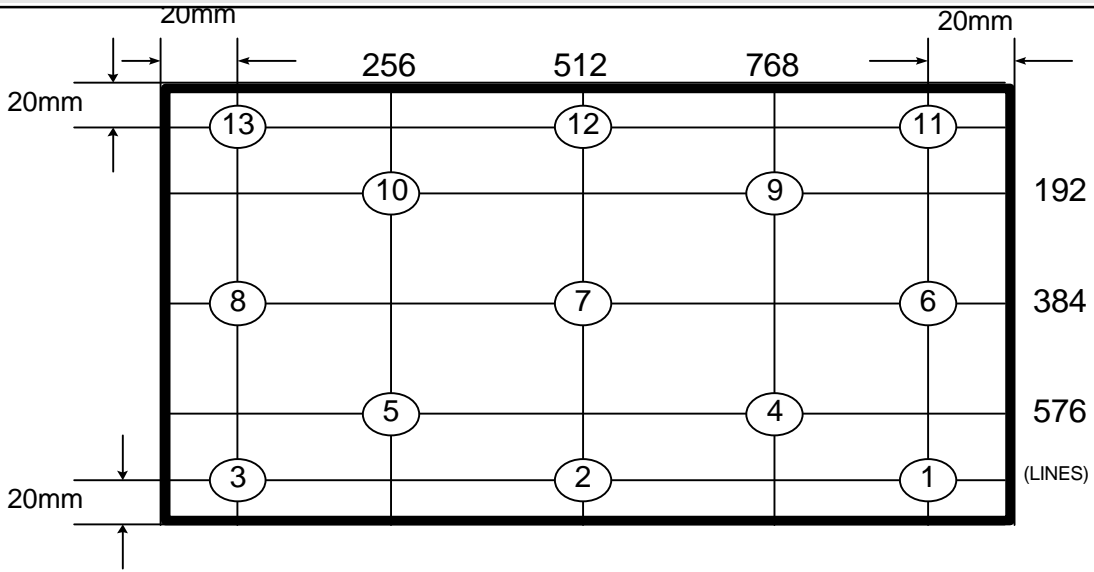

A-3 RESPONSE TIME

The response time is defined as the following figure and shall be measured by switching the input signal for "black" and "white".

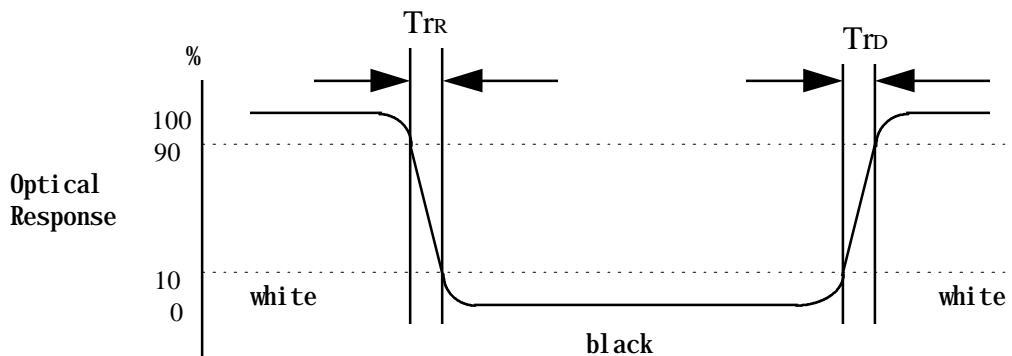

A-4 VIEWING ANGLE

<Definition of viewing angle range>

Product Specification

