

# mass integrated

global part distribution • product lifecycle partner  
excess inventory management • value-ad service provider



Data sheet provided by Mass Integrated

[massintegrated.com](http://massintegrated.com) • [displayalliance.com](http://displayalliance.com)

Please call +1.978.465.6190  
Email: [sales@massintegrated.com](mailto:sales@massintegrated.com)



ISO 9001: 2008

Mass Integrated complies with all DMCA takedown notices. Please send a formal DMCA Takedown Notice to Mass Integrated Systems, Inc. • 18 Henry Graf Jr. Road, Unit 1 • Newburyport, MA 01950.

# SPECIFICATION

## For

# APPROVAL

- (  ) Preliminary Specification  
 (  ) Final Specification

<b>Title</b>	<b>14.1" XGA TFT LCD</b>
--------------	--------------------------

BUYER NAME	
MODEL NAME	

SUPPLIER	LG LCD Inc.
MODEL NAME	LP141XA-A1

SIGNATURE	DATE
Please return 1 copy for our confirmation with your signature and comments.	

SIGNATURE	DATE
APPROVED BY  S. H. Kang	
REVIEWED BY S. C. YUN B. H. KOO	
PREPARED BY H. S. SONG S. J. LEE	
Product Engineering Dept. LG LCD Inc.	

+

**TABLE of CONTENTS**

NO.	ITEM	Page
-	COVER	1/19
-	TABLE of CONTENTS	2/19
-	RECORD of REVISION	3/19
1.	GENERAL DESCRIPTION	4/19
2.	MAXIMUM RATINGS	5/19
3.	ELECTRICAL SPECIFICATIONS	5/19
4.	OPTICAL SPECIFICATIONS	6/19
5.	INTERFACE CONNECTIONS	7/19
6.	SIGNAL TIMING SPECIFICATIONS	9/19
7.	SIGNAL TIMING WAVE FORMS	10/19
8.	COLOR INPUT DATA REFERENCE	12/19
9.	POWER SEQUENCE	13/19
10.	MECHANICAL CHARACTERISTICS	14/19
11.	HANDLING PRECAUTIONS	16/19
12.	INTERNATIONAL STANDARDS	17/19
-	APPENDIX	18/19

## Product Specification

**Record of Revision**

DATE AND VERSION	DESCRIPTION
22 / Jan. / 1999 & Ver. 1.0	Initial Release
12 / Feb. / 1999 & Ver. 1.1	1. To Change Model Name (All Page) LP141X4-C1 → LP141XA-A1  2. To change Power supply current (5 Page) : Typ   Max       Typ   Max 375   510 → 410   570 [mA]  3. To add International Standards (17 Page)
12 / Apr. / 1999 & Ver. 1.2	1. To Changed Color Coordinates (6 Page)  : Min.   Typ    Max       Min.   Typ    Max ① Rx   0.542 0.572 0.602 → 0.548 0.578 0.608 ② Ry   0.320 0.350 0.380 → 0.317 0.347 0.377 ③ Gx   0.267 0.297 0.327 → 0.278 0.308 0.338 ④ Gy   0.519 0.549 0.579 → 0.507 0.537 0.567 ⑤ Bx   0.122 0.152 0.182 → 0.121 0.151 0.181 ⑥ By   0.110 0.140 0.170 → 0.101 0.131 0.161 ⑦ Wy   0.271 0.301 0.331 → 0.281 0.311 0.341 ⑧ Wy   0.312 0.342 0.372 → 0.311 0.341 0.371
28 / May / 1999 & Ver. 1.3	1. To change Power Sequence (13 Page) Lamp On Time : 200[mS] min. → 50[mS] min.
08 / Jul. / 1999 & Ver. 1.4	1. Update Mechanical Drawing(14, 15 Page) 2. Change Power Sequence (13 Page) VDD off time : 20 [mS] max. → 40 [mS] max.

## **1. General Description**

The LG LCD Inc. model LP141XA-A1 LCD is a Color Active Matrix Liquid Crystal Display with an integral Cold Cathode Fluorescent Tube(CCFT) back light system. The matrix employs a - Si Thin Film Transistor as the active element. It is a transmissive type display operating in the normally white mode. This TFT-LCD has a 14.1 inch diagonally measured active display area with XGA resolution(768 vertical by 1024 horizontal pixel array). Each pixel is divided into Red, Green and Blue sub-pixels or dots which are arranged in vertical stripes. Gray scale or the brightness of the sub-pixel color is determined with a 6-bit gray scale signal for each dot, thus, presenting a pallet of more than 262,144 colors.

The LP141XA-A1 LCD is intended to support applications where low power consumption, weight and thickness are critical factors and graphic displays are important. In combination with the vertical arrangement of the sub-pixels, the LP141XA-A1 characteristics provide an excellent flat panel display for office automation products such as portable computers.

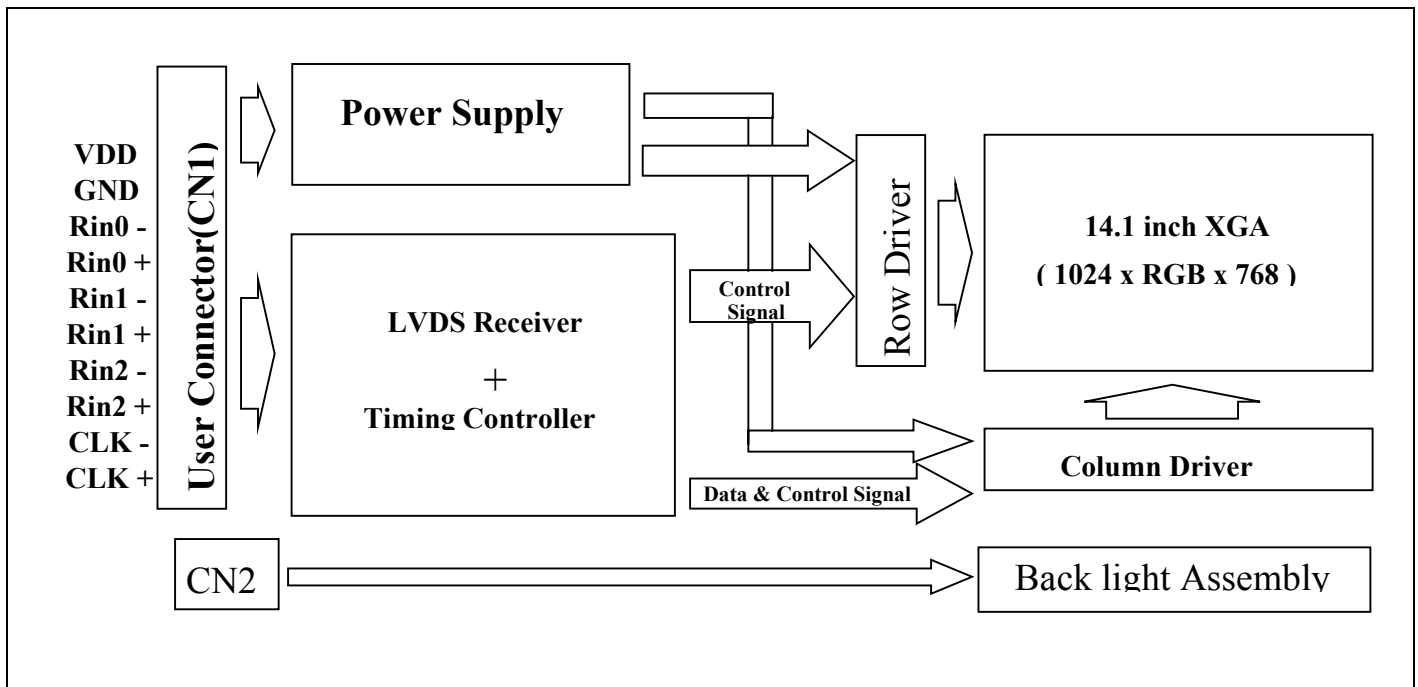

## **General Display Characteristics**

The following are general feature of the model LP141XA-A1 LCD;

Active display area	14.1 inch diagonal
Outsize dimensions	298.5 W x 227.5 H x 5.8 D mm Typ.
Pixel pitch	0.279 mm x 0.279 mm
Pixel format	1024 horiz. By 768 vert. pixels
Color depth	RGB stripe arrangement
Display operating mode	6-bit
Surface treatment	transmissive mode, normally white
	hard coating(3H),
	anti-glare treatment of the front polarizer

**Product Specification**

## 2. Maximum Ratings

The following are maximum values which, if exceeded, may cause faulty operation or damage to the unit.

**Table 1 ABSOLUTE MAXIMUM RATINGS**

Parameter	symbol	Values		Units	Notes
		Min.	Max.		
Power Input Voltage	V <sub>DD</sub>	0	4.0	Vdc	at 25°C
Logic Input Voltage	V <sub>L/H</sub>	-0.3	V <sub>DD</sub> +0.3	Vdc	at 25°C
Operating Temperature	T <sub>OP</sub>	0	+50	°C	1
Storage Temperature	T <sub>ST</sub>	-20	+60	°C	1

Note: 1. The Relative Humidity must not exceed 80% non-condensing at temperatures of 40°C or less.

At temperatures greater than 40°C, the wet bulb temperature must not exceed 39°C.

At low temperature the brightness of CCFL drop and the life time of CCFL become to be short.

2. Under no condition should the unit be exposed to corrosive chemicals.

## 3. Electrical Specifications

The LP141XA-A1 requires two power inputs. One is employed to power the LCD electronics and to derive the voltages to drive the TFT array and liquid crystal. The second input which powers the backlight CCFT, is typically generated by an inverter. The inverter is an external unit to the LCD.

**Table 2 ELECTRICAL CHARACTERISTICS:**

Parameter	Symbol	Values			Units	Notes
		Min.	Typ.	Max.		
<b>MODULE:</b>						
Power Supply Input Voltage	V <sub>DD</sub>	3.0	3.3	3.6	Vdc	
Power Supply Input Current	I <sub>DD</sub>	-	410	570	mA	1,2
Ripple/Noise	-	-	60	100	mV	
Differential input voltage - High	V <sub>IH</sub>	-	-	100	mV	3
for receiver threshold Low	V <sub>IL</sub>	-100	-	-	mV	
<b>BACKLIGHT</b>						
Backlight Input voltage	V <sub>BL</sub>	680	725	850	V <sub>RMS</sub>	4
Backlight Current	I <sub>BL</sub>	3.0	5.0	6.0	mA	
Established starting Voltage				1170	V <sub>RMS</sub>	25±2°C, 5
				1450	V <sub>RMS</sub>	0°C
Operating Frequency	F <sub>BL</sub>	40	60	80	KHz	
CCFL Life Time		10,000			Hours	@ I <sub>BL</sub> = 6mA

Notes 1. The current draw and power consumption specified is for 3.3 Vdc at 25°C.

2. Typical value is measured when displaying black screen.

Maximum power situation measured with alternating vertical lines by 2 black\_white pattern.

For more information see Appendix A-1.

3. LVDS common mode voltage, V<sub>CM</sub>=1.2V

4. The backlight power consumption shown above does not include loss of external inverter.

5. The voltage of inverter is more than the established starting voltage.

## Product Specification

#### 4. Optical Specifications

Optical characteristics are determined after the unit has been 'ON' and stable for approximately 30 minutes in a dark environment at 25°C. The values specified are at an approximate distance 50cm from the LCD surface at a viewing angle of  $\Phi$  and  $\theta$  equal to 0°.

Appendix A presents additional information concerning the specified characteristics.

**Table 3 OPTICAL CHARACTERISTICS**

Parameter		Symbol	Values			Units	Notes
			Min.	Typ.	Max.		
Contrast Ratio		CR	150	250	-	-	1
White Surface Brightness	IBL=6.0mA	SB <sub>WH</sub>	100	120	-	cd/m <sup>2</sup>	2
Brightness Variation		SB <sub>V</sub>	-	-	1.80		3
Response Time	Rise Time	Tr <sub>R</sub>	-	20	40	msec	
	Decay Time	Tr <sub>D</sub>	-	30	50	msec	
Color Coordinates	RED	x	0.548	0.578	0.608	-	6
		y	0.317	0.347	0.377	-	6
	GREEN	x	0.278	0.308	0.338	-	6
		y	0.507	0.537	0.567	-	6
	BLUE	x	0.121	0.151	0.181	-	6
		y	0.101	0.131	0.161	-	6
	WHITE	x	0.281	0.311	0.341	-	6
		y	0.311	0.341	0.371	-	6
Viewing Angle (CR>10:1)	x axis, right ( $\Phi = 0^\circ$ )	$\theta$	45			degree	5
	x axis, left ( $\Phi = 180^\circ$ )	$\theta$	45			degree	5
	y axis, up ( $\Phi = 90^\circ$ )	$\theta$	10			degree	5
	y axis, down ( $\Phi = 270^\circ$ )	$\theta$	30			degree	5

Notes 1. Contrast Ratio (CR) is defined mathematically as:

$$\frac{\text{(Surface Brightness with all white pixels)}}{\text{(Surface Brightness with all black pixels)}}$$

- Surface brightness is 5 spot average of measurement across the LCD surface 50cm from the surface with all pixels displaying white. For more information see Appendix A-2.
- The variation in surface brightness, SB<sub>V</sub> is determined by measuring B<sub>ON</sub> at each test position 1 through 13, and then dividing the maximum B<sub>ON</sub> by the minimum B<sub>ON</sub>. For more information see Appendix A-3.

$$\frac{\text{Maximum (B}_{ON1}, \text{B}_{ON2}, \dots, \text{B}_{ON13})}}{\text{Minimum (B}_{ON1}, \text{B}_{ON2}, \dots, \text{B}_{ON13})}}$$

- Response time is the time required for the display to transition from white to black (Rise Time, Tr<sub>R</sub>) and from black to white (Decay Time, Tr<sub>D</sub>). For additional information see Appendix A-4.
- Viewing angle is the angle at which the contrast ratio is greater than 10. The angles are determined for the horizontal or x axis and the vertical or y axis with respect to the z axis which is normal to the LCD surface. For more information see Appendix A-5.
- Color Coordinates can be changed according to color filter. (In case of changing color filter, we will tell our customer.)

Product Specification

**5. Interface Connections**

This LCD employs two interface connections, a 20 pin connector is used for the module electronics and a two pin connector is used for the integral backlight system.

The electronics interface connector is a model FI-SEB-20P-HF or equivalent.

The pin configuration for the connector is shown in the table below.

**Table 4 MODULE CONNECTOR PIN CONFIGURATION (CN1)**

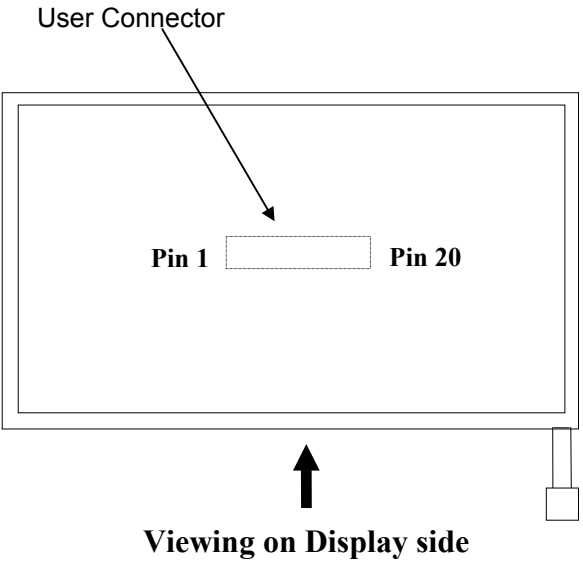
Pin	Symbol	Description	Notes
1	VDD	Power supply, 3.3V	
2	VDD	Power supply, 3.3V	
3	GND	Ground	
4	GND	Ground	
5	Rin0 -	Receiver signal (-)	
6	Rin0 +	Receiver signal (+)	
7	GND	Ground	
8	Rin1 -	Receiver signal (-)	
9	Rin1 +	Receiver signal (+)	
10	GND	Ground	
11	Rin2 -	Receiver signal (-)	
12	Rin2 +	Receiver signal (+)	
13	GND	Ground	
14	CLK -	Clock signal (-)	
15	CLK +	Clock signal (+)	
16	GND	Ground	
17	NC	Reserved	
18	NC	Reserved	
19	GND	Ground	
20	GND	Ground	

- Notes:
1. All GND(ground) pins should be connected together and to GND which should also be connected to the LCD's metal frame.
  2. All V<sub>DD</sub>(power input) pins should be connected together.

**Interface Connections (cont'd)**

The backlight interface connector is a model BHSR-02VS-1, manufactured by JST. The mating connector part number is SM02B-BHSS-1-TB or equivalent. The pin configuration for the connector is shown in the table below.

**Table 5 BACKLIGHT CONNECTOR PIN CONFIGURATION (CN2)**

Pin	Symbol	Description	Notes
1	HV	Lamp power input	1
2	LV	Ground	2

Notes: 1. The input power terminal is white

2. The ground terminal is black.

**6. Signal Timing Specification**

## Product Specification

**6.1. Interface Signal Timing**

This is the characteristics of the interface timing parameters. LVDS input timing and LCD interface timing diagrams are shown in 7.1 and 7.2

LP141XA-A1 with LVDS transmitter recommend to connect to the Display Enable, Horizontal sync, Vertical sync, Clock signal from Video signal controller to input of Transmitter simultaneously.

ITEM	SIGNAL	ITEM	SYMBOL	MIN.	TYP.	MAX.	UNIT
LVDS Timing (Note 1)	Clock	Frequency	$f_{CLKIN}$	-	65	66.6	MHz
		Period	$t_{CLKIN}$	15	15.4	-	ns
	LVDS Low to High time	Transition time	LLHT	-	0.75	1.5	ns
	LVDS High to Low time	Transition time	LHLT	-	0.75	1.5	ns
	Set up time, serial bits	Receiver Input Strobe Bit 0	$t_0$	-0.4	0	0.3	ns
		Receiver Input Strobe Bit 1	$t_1$	1.8	2.2	2.5	ns
		Receiver Input Strobe Bit 2	$t_2$	4.0	4.4	4.7	ns
		Receiver Input Strobe Bit 3	$t_3$	6.2	6.6	6.9	ns
		Receiver Input Strobe Bit 4	$t_4$	8.4	8.8	9.1	ns
		Receiver Input Strobe Bit 5	$t_5$	10.6	11	11.3	ns
Receiver Input Strobe Bit 6		$t_6$	12.8	13.2	13.5	ns	
LVDS Transmitter Input (note 2-4)	DENA	Low width	$t_{WDL}$	100	-	-	$t_{CLKIN}$
		Horizontal Front Porch	$t_{HFP}$	0	-	-	$t_{CLKIN}$
		Horizontal Back Porch	$t_{HBP}$	5	-	-	$t_{CLKIN}$
		Vertical Front Porch	$t_{VFP}$	0	-	-	$t_H$
		Vertical Back Porch	$t_{VBP}$	4	-	-	$t_H$
	HD	Frequency	$f_H$	-	48.5	55.9	kHz
		Period	$t_H$	1100	1340	-	$t_{CLKIN}$
		Low width	$t_{WHL}$	1	-	-	$t_{CLKIN}$
	VD	Frequency	$f_V$	-	60	62	Hz
		Period	$t_V$	772	809	-	$t_H$
		Low width	$t_{WVL}$	0.5	-	-	$t_H$

Note : 1. Measurement is made at panel side flex connector with dummy 100 ohm termination.

2. Polarities of HD and VD are negative.

3. DENA should always be positive polarity.

4. CLKIN should appear during all invalid period. HD should appear during invalid period of the frame cycle.



### 7.2 LCD Interface Timing

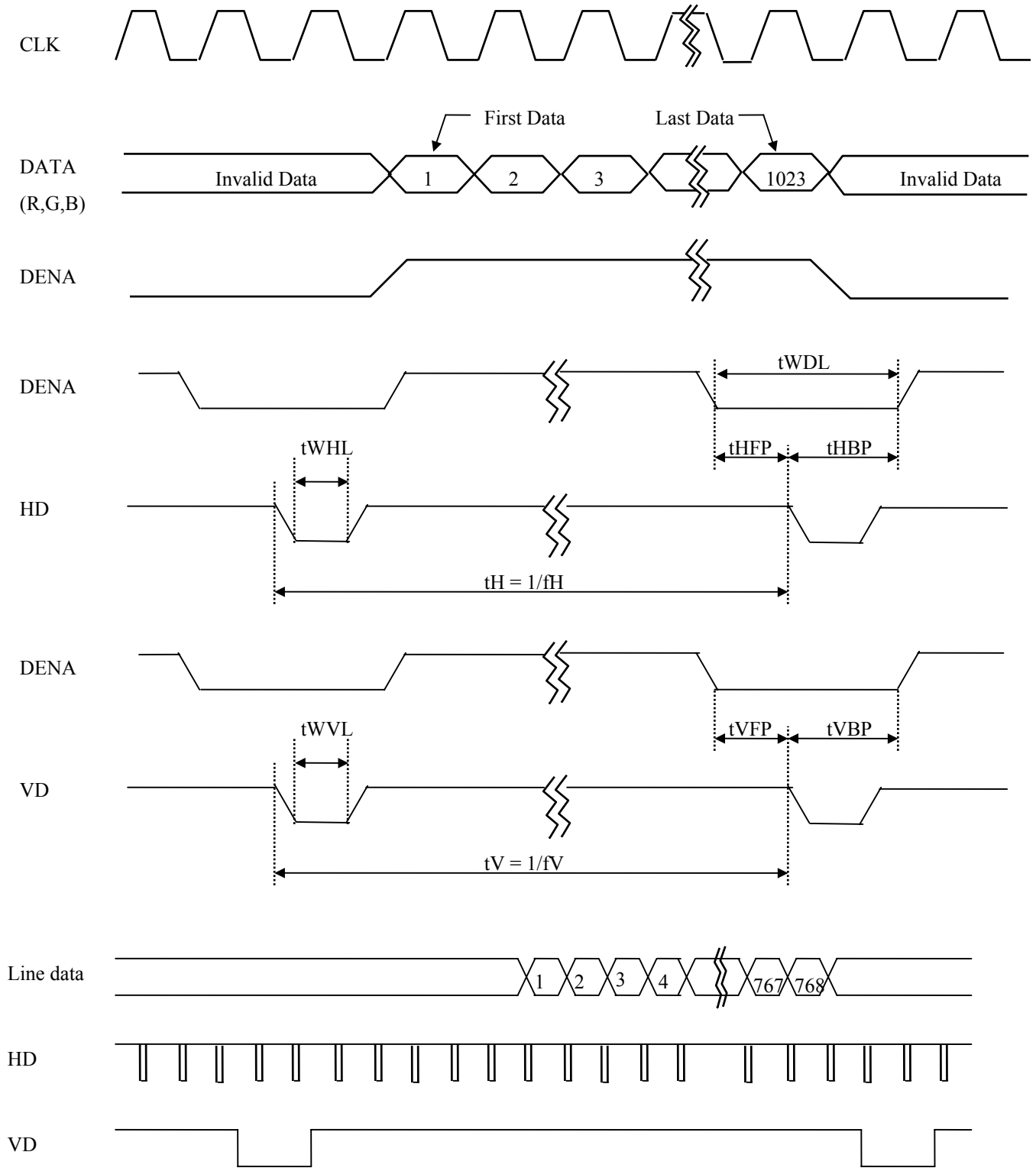

**8. Color Input Data Reference**

The brightness of each primary color(red, green and blue) is based on the 6-bit gray scale data input for the color; the higher the binary input, the brighter the color. The table below provides a reference for color versus data input.

**Table 6 COLOR DATA REFERENCE**

Color		Input Color Data																	
		Red						Green						Blue					
		R5	R4	R3	R2	R1	R0	G5	G4	G3	G2	G1	G0	B5	B4	B3	B2	B1	B0
Basic Colors	Black	0	0	0	0	0	0	0	0	0	0	0	0	0	0	0	0	0	0
	Red(00)	1	1	1	1	1	1	0	0	0	0	0	0	0	0	0	0	0	0
	Green(00)	0	0	0	0	0	0	1	1	1	1	1	1	0	0	0	0	0	0
	Blue(00)	0	0	0	0	0	0	0	0	0	0	0	0	1	1	1	1	1	1
	Cyan	0	0	0	0	0	0	1	1	1	1	1	1	1	1	1	1	1	1
	Magenta	1	1	1	1	1	1	0	0	0	0	0	0	1	1	1	1	1	1
	Yellow	1	1	1	1	1	1	1	1	1	1	1	1	0	0	0	0	0	0
	White	1	1	1	1	1	1	1	1	1	1	1	1	1	1	1	1	1	1
Red	Red(63) Black	0	0	0	0	0	0	0	0	0	0	0	0	0	0	0	0	0	0
	Red(62)	0	0	0	0	0	1	0	0	0	0	0	0	0	0	0	0	0	0
	Red(61)	0	0	0	0	1	0	0	0	0	0	0	0	0	0	0	0	0	0
	:	:	:	:	:	:	0	0	0	0	0	0	0	0	0	0	0	0	
	Red(02)	1	1	1	1	0	1	0	0	0	0	0	0	0	0	0	0	0	0
	Red(01)	1	1	1	1	1	0	0	0	0	0	0	0	0	0	0	0	0	0
	Red(00)	1	1	1	1	1	1	0	0	0	0	0	0	0	0	0	0	0	0
Green	Green(63) Black	0	0	0	0	0	0	0	0	0	0	0	0	0	0	0	0	0	0
	Green(62)	0	0	0	0	0	0	0	0	0	0	1	0	0	0	0	0	0	
	Green(61)	0	0	0	0	0	0	0	0	0	0	1	0	0	0	0	0	0	
	:	:	:	:	:	:	0	0	0	0	0	0	0	0	0	0	0	0	
	Green(02)	0	0	0	0	0	0	1	1	1	1	0	1	0	0	0	0	0	
	Green(01)	0	0	0	0	0	0	1	1	1	1	1	0	0	0	0	0	0	
	Green(00)	0	0	0	0	0	0	1	1	1	1	1	1	0	0	0	0	0	
Blue	Blue(63) Black	0	0	0	0	0	0	0	0	0	0	0	0	0	0	0	0	0	0
	Blue(62)	0	0	0	0	0	0	0	0	0	0	0	0	0	0	0	0	0	1
	Blue(61)	0	0	0	0	0	0	0	0	0	0	0	0	0	0	0	0	1	0
	:	:	:	:	:	:	0	0	0	0	0	0	;	:	:	:	:	:	
	Blue(02)	0	0	0	0	0	0	0	0	0	0	0	0	1	1	1	1	0	1
	Blue(01)	0	0	0	0	0	0	0	0	0	0	0	0	1	1	1	1	1	0
	Blue(00)	0	0	0	0	0	0	0	0	0	0	0	0	1	1	1	1	1	1

**9. Power Sequence**

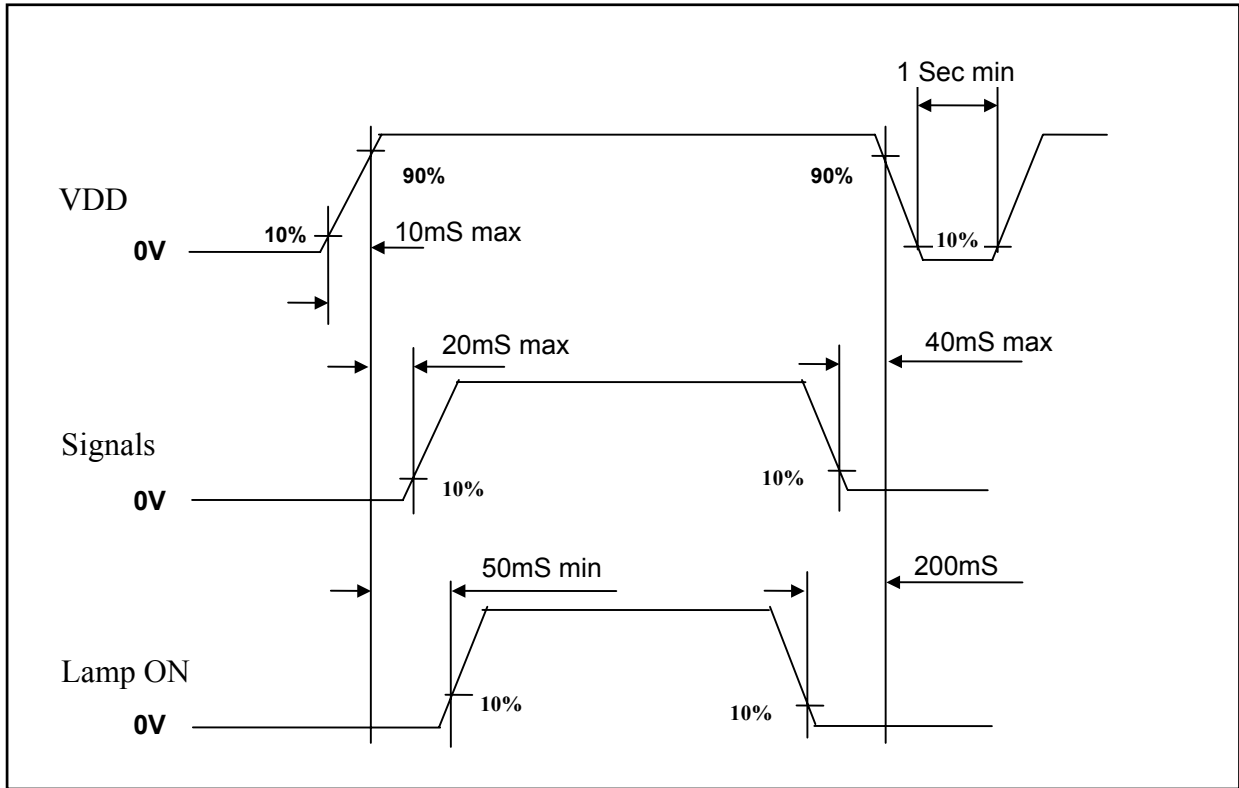

- Notes :
1. Please avoid floating state of interface signal at invalid period.
  2. When the interface signal is invalid, be sure to pull down the power supply for LCD  $V_{DD}$  to 0V.

Product Specification

**10. Mechanical Characteristics**

The chart below provides general mechanical characteristics for the model LP141XA-A1 LCD. The surface of the LCD has an anti-glare coating to minimize reflection and a 3H hard coating to reduce scratching. In addition, the figure below is a detailed mechanical drawing of the LCD. Note that dimension are given for reference purposes only.

Outside dimensions	Width	298.5 mm typ.
	Height	227.5 mm typ.
	Thickness	5.8 mm typ.
Active Display area	Width	285.7 mm
	Height	214.3 mm
	Diagonal	14.1 inch
Weight		590 g max.

< Front View >

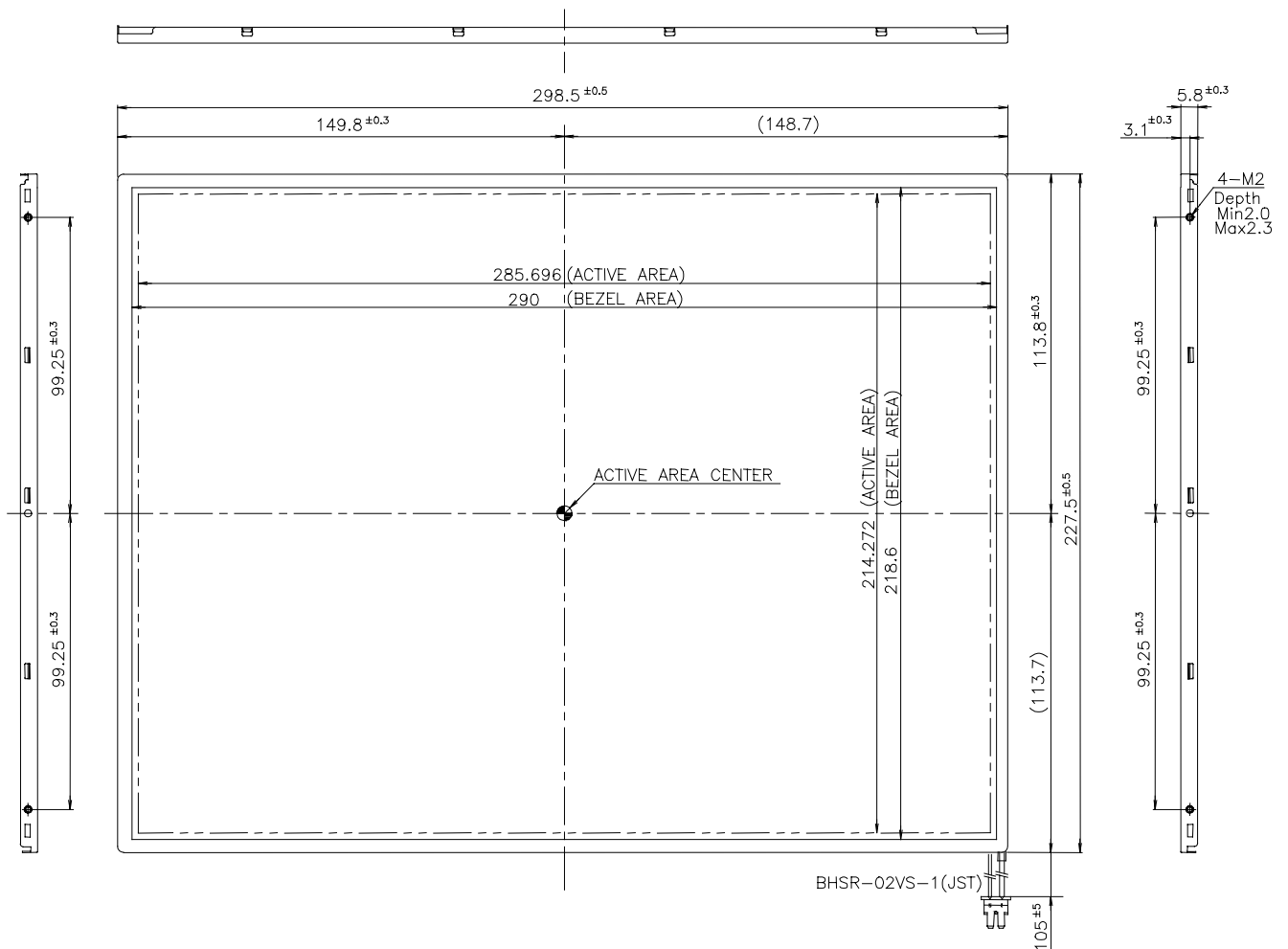

< Rear View >

Product Specification

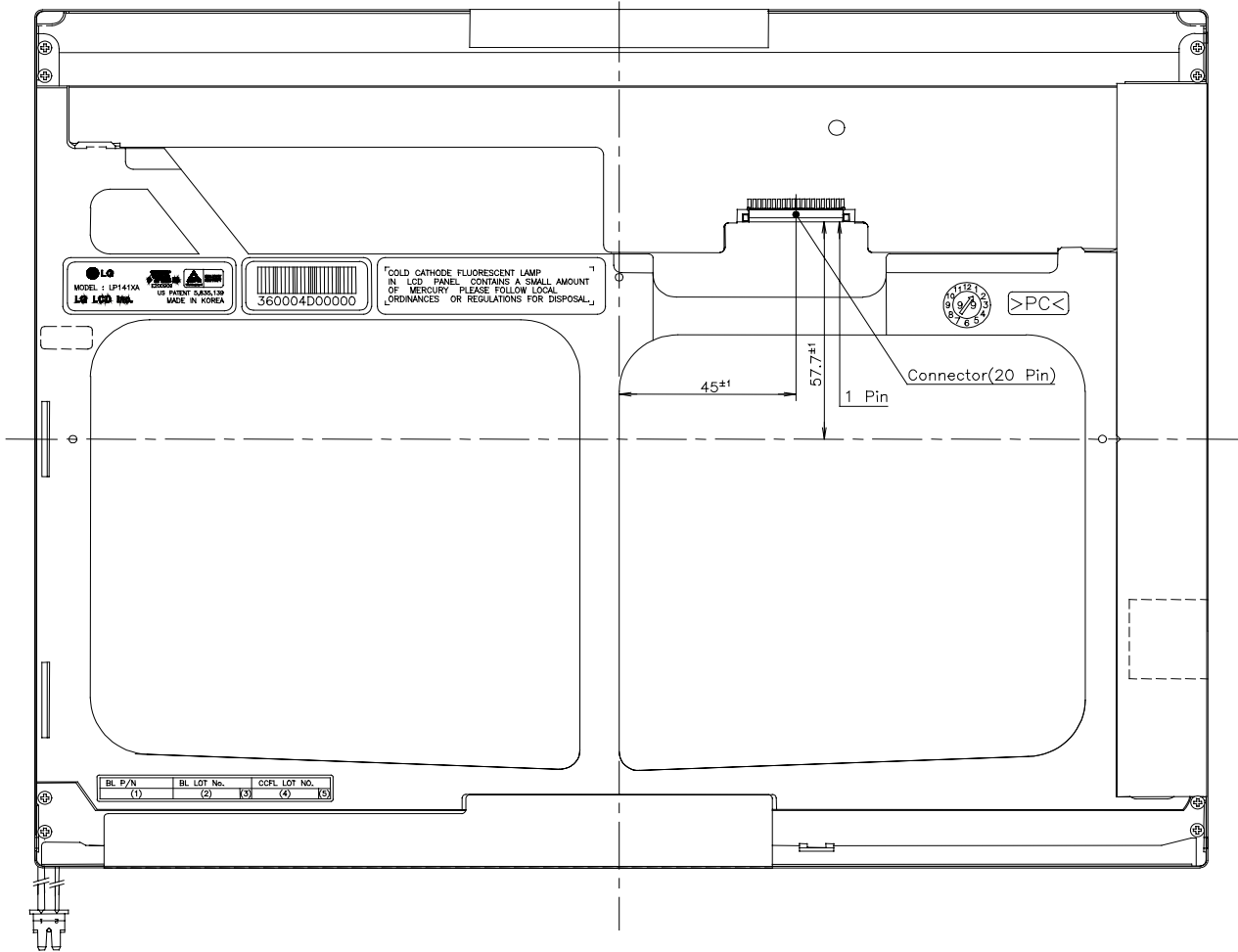

Structure of joint

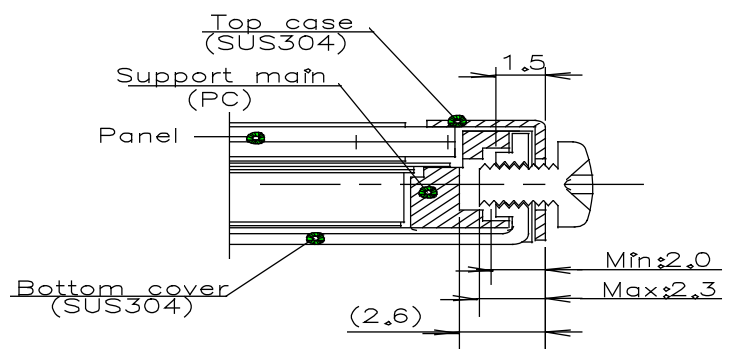

\* Mounting Screw depth : 2.0[mm] Min. 2.3[mm] Max.  
\* Torque : 1.3 ~ 1.5 [kgf · cm]

**11. Handling Precautions**

## Product Specification

Please pay attention to the followings when you use this TFT/LCD module with Back-light unit.

**11.1.MOUNTING PRECAUTION**

- 1) You must mount Module using mounting holes arranged on metal frame sides. Be sure to turn off the power when connecting or disconnecting the circuit.
- 2) Note that the polarizers are easily damaged. Pay attention not to scratch or press this surface with any hard object.
- 3) When the LCD surface become dirty, please wipe it off with a soft material. (ie. cotton ball)
- 4) Protect the module from the ESD as it may damage the electronic circuit (C-MOS). Make certain that treatment person's body are grounded through wrist bend.
- 5) Do not disassemble the module and be careful not to incur a mechanical shock that might occur during installation. It may cause permanent damage.
- 6) Do not leave the module in high temperatures, Particularly in areas of high humidity for a long time.
- 7) The module not be expose to the direct sunlight.
- 8) Avoid contact with water as it may a short circuit within the module.

**11.2 OPERATING PRECAUTION**

- 1) The spike noise causes the mis-operation of circuits. Be lower the spike noise as follows :  
 $VDD = \pm 200mV$ ,  $V1 = \pm 200mV$  ( Over and under shoot voltage.)
- 2) Response time depends on the temperature. (In lower temperature, it becomes longer.)
- 3) Brightness depends on the temperature. (In lower temperature, it becomes lower.) And in lower temperature, response time (Required time that brightness is stable after turn on) becomes longer.
- 4) Be careful for condensation at suddern temperature change. Condensation make damage to polarizer or electrical contact part. And after fading condensation, smear or spot will occur.
- 5) When fixed pattern are displayed at long times, remnant image is likely to occur.
- 6) Module has high frequency circuit. If you need to shield the electromagnetic noise. Please do in yours.
- 7) When Back-light unit is operating, it sounds. If you need to shield the noise, please do in yours.

**11.3 ELECTROSTATIC DISCHARGE CONTROL**

Since module is composed with electronic circuit, it is not strong to electrostatic discharge.

Make certain that treatment persons are connected to ground through list band etc.. And don't touch I/F pin directly.

**11.4 PRECAUTION FOR STRONG LIGHT EXPOSURE.**

Strong light exposure causes degradation of polarizer and color filter.

**11.5 STORAGE**

When storing module as spares for long time, the following precautions are necessary.

- 1) Store them in a dark place : do not expose then to sunlight or fluorescent light. Keep the temperature between 5 and 35 at normal humidity.
- 2) The polarizer surface should not come in contact with any other object. It is recommended that they be stored in the container in which they were shipped.

**11.6 HANDLING PRECAUTIONS FOR PROTECTION FILM**

- 1) When the protection film is peeled off, static electricity is generated between the film and the polarizer. This film should be peeled off slowly and carefully by people who are electrically grounded and with well ion-blown equipment or in such a condition. etc.
- 2) The protection film is attached the polarizer with a small amount of glue. If some stress is applied to rub the protection film against the polarizer during the time you peel off the film, the glue is apt to remain more on the polarizer. So please carefully peel off the protection film without rubbing it against the polarizer.
- 3) When the module with protection film attached is stored for long time, sometimes there remains a very small amount of glue still on the polarizer after the protection film is peeled off. Please refrain from storing the module at the high temperature and high humidity for glue is apt to remain in these condition.
- 4) The glue may be taken for the modules failure, but you can remove the glue easily. When the glue remains on the polarizer surface or its vestige is recognized, please wipe them off with absorbent cotton waste or other soft material like chamois soaked with Normal-hexane.

**12. International Standards**

## 12.1. Safety

- UL1950 "Safety of Information Technology Equipment Including Electrical Business Equipment. Third Edition" Underwriters Laboratories, Inc. 1995
- CAS C22.2 "Safety of Information Technology Equipment Including Electrical Business Equipment. Third Edition" Canadian Standards Association, 1995
- EN 60950 "Safety of Information Technology Equipment Including Electrical Business Equipment." European Committee for Electrotechnical Standardization(CENELEC), 1995  
Ref. No. EN 60950: 1992 + A1: 1993 + A2: 1993 + A3: 1995 E  
(IEC 950: 1991 + A1: 1992 + A2: 1993 + A3: 1995, modified )

## 12.2. EMC

- ANSI C63.4 "Methods of Measurement of Radio-Noise Emissions from Low-Voltage Electrical and Electronic Equipment in the Range of 9kHz to 40GHz." American National Standards Institute(ANSI),1992.
- C.I.S P.R "Limits and Methods of Measurement of Radio Interference Characteristics of Information Technology Equipment." International Special Committee on Radio Interference
- EN 55 022 "Limits and Methods of Measurement of Radio Interference Characteristics of Information Technology Equipment." European Committee for Electrotechnical Standardization (CENELEC),1988

※. **APPENDIX**

**A-1 BLACK Pattern & Alternating Vertical Lines by 2 Black\_White Pattern**

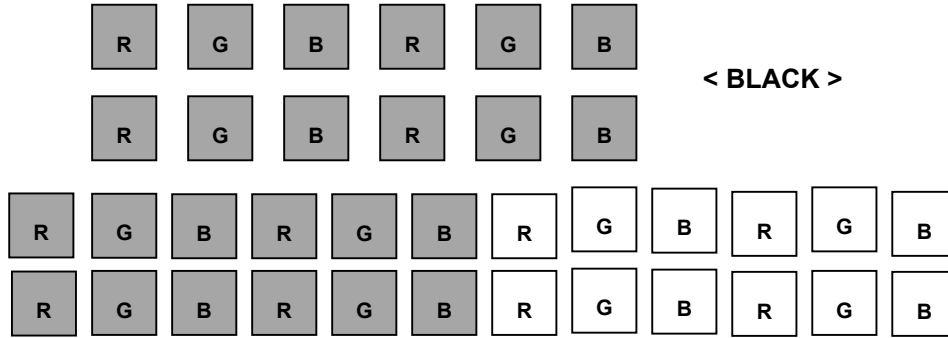

**A-2 BRIGHTNESS**

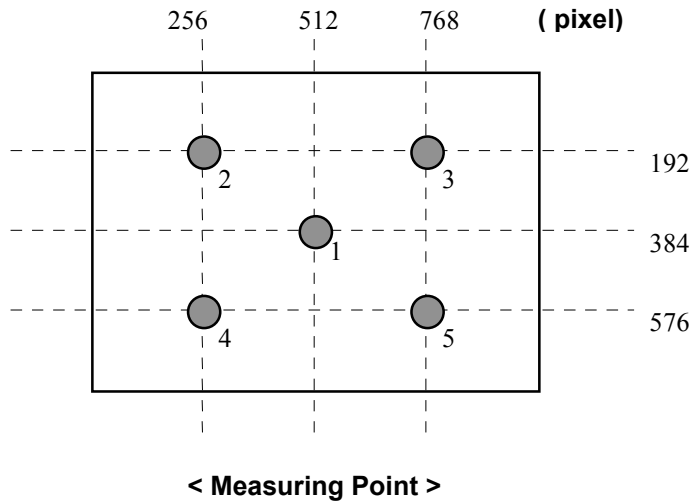

**A-3. 13 SPOT LUMINANCE VARIATION MEASUREMENT LOCATIONS**

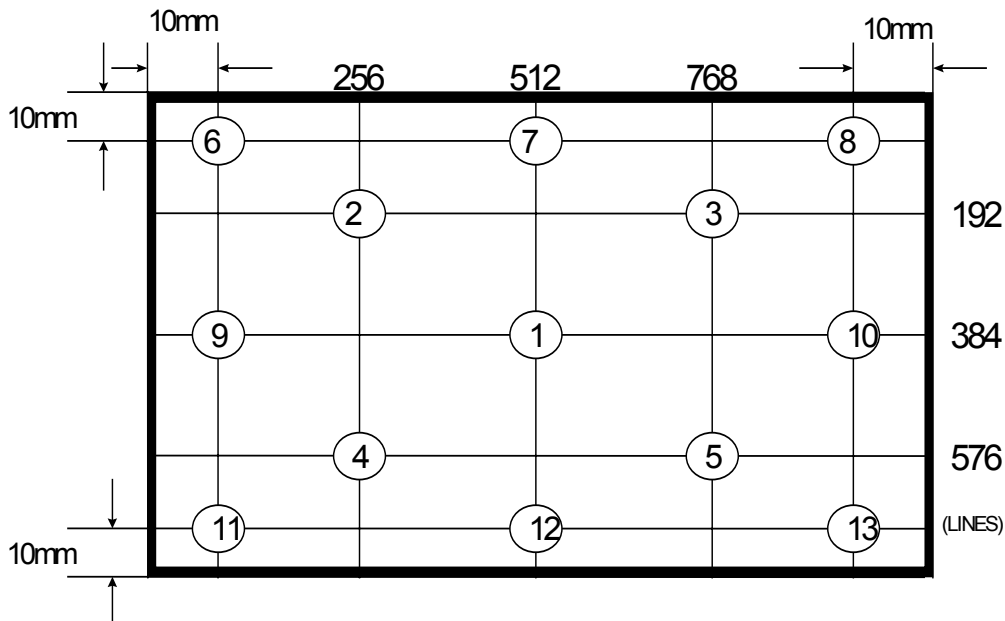

Product Specification

**A-4 RESPONSE TIME**

The response time is defined as the following figure and shall be measured by switching the input signal for "black" and "white".

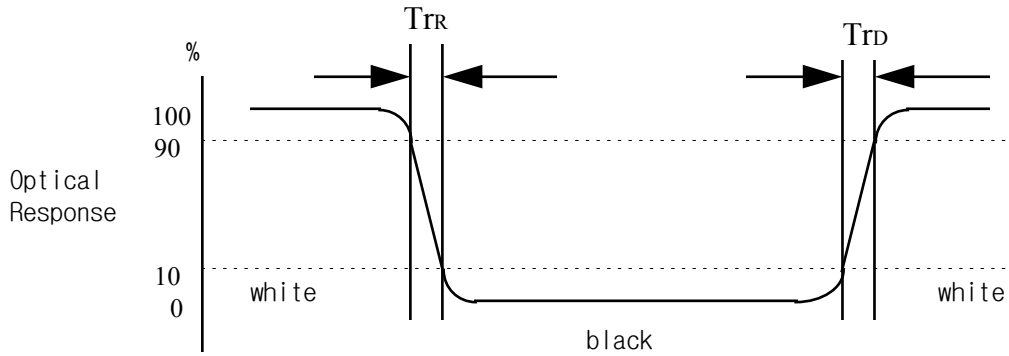

**A-5 VIEWING ANGLE**

<Definition of viewing angle range>

