

mass integrated

global part distribution • product lifecycle partner
excess inventory management • value-ad service provider



Data sheet provided by Mass Integrated

massintegrated.com • displayalliance.com

Please call +1.978.465.6190
Email: sales@massintegrated.com



ISO 9001: 2008

Mass Integrated complies with all DMCA takedown notices. Please send a formal DMCA Takedown Notice to Mass Integrated Systems, Inc. • 18 Henry Graf Jr. Road, Unit 1 • Newburyport, MA 01950.

Product Specification

Contents

No	ITEM	Page
	COVER	1
	CONTENTS	2
	RECORD OF REVISIONS	3
1	GENERAL DESCRIPTION	4
2	ABSOLUTE MAXIMUM RATINGS	5
3	ELECTRICAL SPECIFICATIONS	6
3-1	ELECTRICAL CHARACTREISTICS	6
3-2	INTERFACE CONNECTIONS	8
3-3	SIGNAL TIMING SPECIFICATIONS	9
3-4	SIGNAL TIMING WAVEFORMS	9
3-5	COLOR INPUT DATA REFERNECE	10
3-6	POWER SEQUENCE	11
4	OPTICAL SFECIFICATIONS	12
5	MECHANICAL CHARACTERISTICS	16
6	RELIABLITY	20
7	INTERNATIONAL STANDARDS	21
7-1	SAFETY	21
7-2	EMC	21
8	PACKING	22
8-1	DESIGNATION OF LOT MARK	22
8-2	PACKING FORM	22
9	PRECAUTIONS	23
9-1	MOUNTING PRECAUTIONS	23
9-2	OPERATING PRECAUTIONS	23
9-3	ELECTROSTATIC DISCHARGE CONTROL	24
9-4	PRECAUTIONS FOR STRONG LIGHT EXPOSURE	24
9-5	STORAGE	24
9-6	HANDLING PRECAUTIONS FOR PROTECTION FILM	24
A	APPENDIX. Enhanced Extended Display Identification Data	25

Product Specification

1. General Description

The LP150X08 is a Color Active Matrix Liquid Crystal Display with an integral Cold Cathode Fluorescent Lamp(CCFL) backlight system. The matrix employs a-Si Thin Film Transistor as the active element. It is a transmissive type display operating in the normally white mode. This TFT-LCD has 15.0 inches diagonally measured active display area with XGA resolution(768 vertical by 1024 horizontal pixel array) Each pixel is divided into Red, Green and Blue sub-pixels or dots which are arranged in vertical stripes. Gray scale or the brightness of the sub-pixel color is determined with a 6-bit gray scale signal for each dot, thus, presenting a palette of more than 262,144 colors.

The LP150X08 has been designed to apply the interface method that enables low power, high speed, low EMI.

The LP150X08 is intended to support applications where thin thickness, low power are critical factors and graphic display are important. In combination with the vertical arrangement of the sub-pixels, the LP150X08 characteristics provide an excellent flat display for office automation products such as Notebook PC.

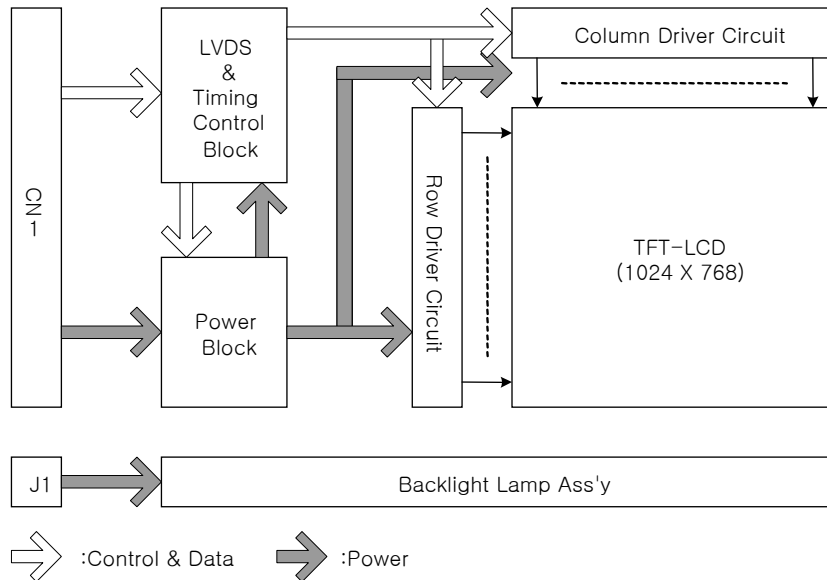

General Features

Active Screen Size	15.0 inches(38.1cm) diagonal
Outline Dimension	317.3(H) x 241.5(V) x 5.7(D) mm(Typ.)
Pixel Pitch	0.297 mm x 0.297 mm
Pixel Format	1024 horiz. By 768 vert. Pixels RGB strip arrangement
Color Depth	6-bit, 262,144 colors
Luminance, White (5P)	150 cd/m ² (Typ.)
Power Consumption	4.66W
Weight	540 g (typ.)
Display Operating Mode	Transmissive mode, normally white
Surface Treatment	Hard coating(3H) Anti-glare treatment of the front polarizer

2. Absolute Maximum Ratings

The following are maximum values which, if exceeded, may cause faulty operation or damage to the unit.

Table 1. ABSOLUTE MAXIMUM RATINGS

Parameter	Symbol	Values		Units	Notes
		Min	Max		
Power Input Voltage-ON	VCC	2.7	4.0	Vdc	at 25 ± 5°C
Power Input Voltage-OFF	GND	-0.3	0.3	Vdc	at 25 ± 5°C
Operating Temperature	TOP	0	50	°C	1
Storage Temperature	TST	-20	60	°C	1
Operating Ambient Humidity	HOP	10	90	%RH	1
Storage Humidity	HST	10	90	%RH	1
Electrostatic Durability (ESD)	VESD	± 8.0		kV	2

Note : 1. Temperature and relative humidity range are shown in the figure below.

Wet bulb temperature should be 39°C Max, and no condensation of water.

2. Condition 1) Non-operation, 150pF-330Ω, 25°C, 40~60%RH
- 2) I/F Connector pins are subjected.
- 3) The surface of Metal bezel and LCD are subjected.
- 4) Discharge interval time 1sec, 10 times each place

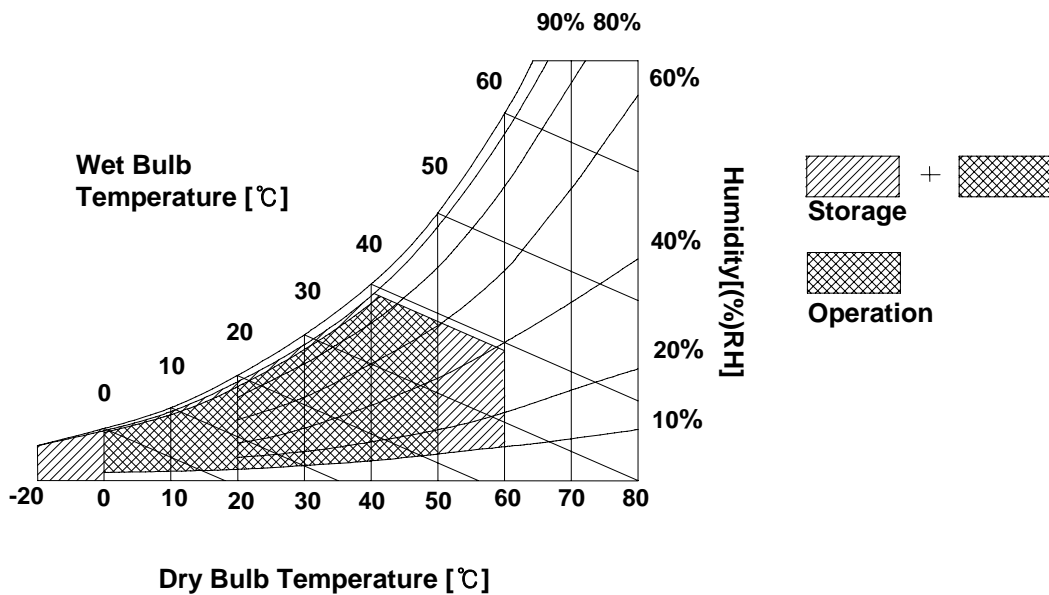

Product Specification

3. Electrical Specifications

3-1. Electrical Characteristics

The LP150X08 requires two power inputs. One is employed to power the LCD electronics and to drive the TFT array and liquid crystal. The second input which powers the CCFL, is typically generated by an inverter. The inverter is an external unit to the LCD.

Table 2. ELECTRICAL CHARACTERISTICS

Parameter	Symbol	Values			Unit	Notes
		Min	Typ	Max		
MODULE :						
Power Supply Input Voltage	VCC	3.0	3.3	3.6	Vdc	
Power Supply Input Current	I _{CC}	-	230	265	mA	1
Power Consumption	P _c	-	0.76	0.87	Watt	1
Differential Impedance	Z _m	90	100	110	ohm	2
LAMP :						
Operating Voltage	V _{BL}	655	685	805	V _{RMS}	3
Operating Current	I _{BL}	3.0	5.0	6.0	mA _{RMS}	
Established Starting Voltage	V _s					4
	at 25 °C	-	-	1140	V _{RMS}	
	at 0 °C	-	-	1370	V _{RMS}	
Operating Frequency	f _{BL}	45	58	80	kHz	5
Discharge Stabilization Time	T _s	-	-	3	Min	6
Power Consumption	P _{BL}	-	3.9	4.3	Watt	7
Life Time		10,000	-	-	Hrs	8

Note : The design of the inverter must have specifications for the lamp in LCD Assembly.

The performance of the Lamp in LCM, for example life time or brightness, is extremely influenced by the characteristics of the DC-AC inverter. So all the parameters of an inverter should be carefully designed so as not to produce too much leakage current from high-voltage output of the inverter. When you design or order the inverter, please make sure unwanted lighting caused by the mismatch of the lamp and the inverter(no lighting, flicker, etc) never occurs. When you confirm it, the LCD-Assembly should be operated in the same condition as installed in you instrument.

1. The specified current and power consumption are under the VCC=3.3V, 25°C, f_v=60Hz condition whereas Mosaic pattern is displayed and f_v is the frame frequency.
2. This impedance value is needed to proper display and measured from LVDS T_x to the mating connector.
3. The variance of the voltage is ± 10%.
4. The voltage above V_s should be applied to the lamps for more than 1 second for start-up. Otherwise, the lamps may not be turned on. The used lamp current is the lamp typical current.

Product Specification

5. The output of the inverter must have symmetrical(negative and positive) voltage waveform and symmetrical current waveform.(Unsymmetrical ratio is less than 10%) Please do not use the inverter which has unsymmetrical voltage and unsymmetrical current and spike wave.
Lamp frequency may produce interface with horizontal synchronous frequency and as a result this may cause beat on the display. Therefore lamp frequency shall be as away possible from the horizontal synchronous frequency and from its harmonics in order to prevent interference.
 6. Let's define the brightness of the lamp after being lighted for 5 minutes as 100%.
 T_s is the time required for the brightness of the center of the lamp to be not less than 95%.
 7. The lamp power consumption shown above does not include loss of external inverter.
The used lamp current is the maximum lamp current ($6.0\text{mA}_{\text{RMS}}$).
 8. The life is determined as the time at which brightness of the lamp is 50% compared to that of initial value at the maximum lamp current($6.0\text{mA}_{\text{RMS}}$) on condition of continuous operating at $25 \pm 2^\circ\text{C}$
 9. Requirements for a system inverter design, which is intended to have a better display performance, a better power efficiency and a more reliable lamp, are following.
It shall help increase the lamp lifetime and reduce leakage current.
 - a. The asymmetry rate of the inverter waveform should be less than 10%.
 - b. The distortion rate of the waveform should be within $\sqrt{2} \pm 10\%$.
- * Inverter output waveform had better be more similar to ideal sine wave.

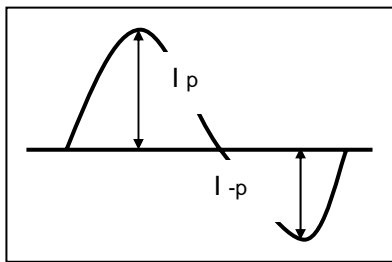

* Asymmetry rate:

$$\frac{|I_p - I_{-p}|}{I_{\text{rms}}} * 100\%$$

* Distortion rate

$$I_p \text{ (or } I_{-p}) / I_{\text{rms}}$$

- ※ Do not attach a conducting tape to lamp connecting wire.
If the lamp wire attach to a conducting tape, TFT-LCD Module has a low luminance and the inverter has abnormal action. Because leakage current is occurred between lamp wire and conducting tape.

Product Specification

3-2. Interface Connections

The interface connections are compatible with **ISP (Industry Standard Panels) 15.0" Mounting and Top Level Interface Requirements (Version2, June,2000)** defined by **SPWG (Standard Panels Working Group)**. This LCD employs two interface connections, a 30 pin connector is used for the module electronics and the other connector is used for the integral backlight system.

The electronics interface connector is a model GT101-30S-HR11 manufactured by LG Cable. The pin configuration for the connector is shown in the table below.

Table 3. MODULE CONNECTOR PIN CONFIGURATION (CN1)

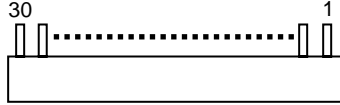
Pin	Symbol	Description	Notes
1	VSS	Ground	[LVDS Transmitter] TI, SN75LVDS84 or equivalent
2	VCC	Power Supply, 3.3V Typ.	
3	VCC	Power Supply, 3.3V Typ.	
4	VEDID	DDC 3.3V power	[LVDS Receiver] THINE, THC63LVDF64A
5	NC	No Connection	
6	ClkEDID	DDC Clock	[Connector] LCD : GT101-30S-HR11, LG Cable * Hirose KN07LR-30S-1H / JAE FI-XB30SR-HF or equivalent. Matching : JAE FI-X30M or equivalent
7	DATAEDID	DDC Data	
8	R _{IN} 0 -	- LVDS differential data input (R0-R5, G0)	
9	R _{IN} 0 +	+ LVDS differential data input (R0-R5, G0)	
10	VSS	Ground	
11	R _{IN} 1 -	- LVDS differential data input (G1-G5, B0-B1)	
12	R _{IN} 1 +	+ LVDS differential data input (G1-G5, B0-B1)	
13	VSS	Ground	
14	R _{IN} 2 -	- LVDS differential data input (B2-B5, HS, VS, DE)	
15	R _{IN} 2 +	+ LVDS differential data input (B2-B5, HS, VS, DE)	
16	VSS	Ground	[Connector pin arrangement]  LCD rear view
17	ClkIN -	- LVDS differential clock input	
18	ClkIN +	+ LVDS differential clock input	
19	VSS	Ground	
20	NC	No Connection	
21	NC	No Connection	
22	VSS	Ground	
23	NC	No Connection	
24	NC	No Connection	
25	VSS	Ground	
26	NC	No Connection	
27	NC	No Connection	
28	VSS	Ground	
29	NC	No Connection	
30	NC	No Connection	

Note: All GND(ground) pins should be connected together and to GND which should also be connected to the LCD's metal frame. All VCC (power input) pins should be connected together.

The backlight interface connector is JST BHSR-02VS-1 or equivalent. The mating connector part number is SM02B-BHSS-1 or equivalent.

Table 4. BACKLIGHT CONNECTOR PIN CONFIGURATION (J1)

Pin	Symbol	Description	Notes
1	HV	Power supply for lamp (High voltage side)	1
2	LV	Power supply for lamp (Low voltage side)	1

Notes : 1. The high voltage side terminal is colored pink and the low voltage side terminal is black.

3-3. Signal Timing Specifications

This is the signal timing required at the input of the User connector. All of the interface signal timing should be satisfied with the following specifications and specifications of LVDS Tx/Rx for it's proper operation.

Table 5. TIMING TABLE

ITEM	Symbol	Min	Typ	Max	Unit	Note	
DCLK	Frequency	fCLK	65	65	65	MHz	15.4ns
Hsync	Period	tHP	1206	1344	1364	tCLK	
	Width	tWH	8	136	-		
Vsync	Period	tVP	780	806	830	tHP	
	Frequency	fV	60	60	60		
	Width	tWV	1	6	24		
Data Enable	Horizontal back porch	tHBP	10	160	-	tCLK	
	Horizontal front porch	tHFP	10	24	-		
	Vertical back porch	tVBP	7	29	-	tHP	
	Vertical front porch	tVFP	1	3	-		

3-4. Signal Timing Waveforms

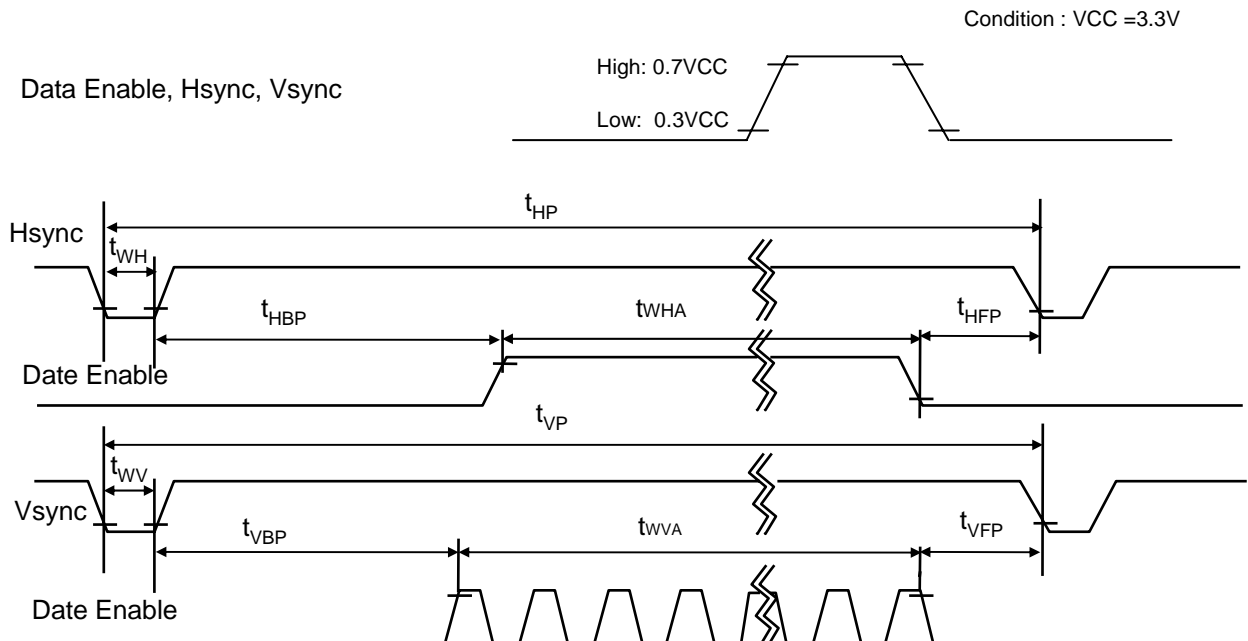

Product Specification

3-5. Color Input Data Reference

The brightness of each primary color (red, green and blue) is based on the 6-bit gray scale data input for the color ; the higher the binary input, the brighter the color. The table below provides a reference for color versus data input.

Table 6. COLOR DATA REFERENCE

Color		Input Color Data																	
		RED						GREEN						BLUE					
		MSB				LSB		MSB				LSB		MSB		LSB			
		R 5	R 4	R 3	R 2	R 1	R 0	G 5	G 4	G 3	G 2	G 1	G 0	B 5	B 4	B 3	B 2	B 1	B 0
Basic Color	Black	0	0	0	0	0	0	0	0	0	0	0	0	0	0	0	0	0	0
	Red	1	1	1	1	1	1	0	0	0	0	0	0	0	0	0	0	0	0
	Green	0	0	0	0	0	0	1	1	1	1	1	1	0	0	0	0	0	0
	Blue	0	0	0	0	0	0	0	0	0	0	0	0	1	1	1	1	1	1
	Cyan	0	0	0	0	0	0	1	1	1	1	1	1	1	1	1	1	1	1
	Magenta	1	1	1	1	1	1	0	0	0	0	0	0	1	1	1	1	1	1
	Yellow	1	1	1	1	1	1	1	1	1	1	1	1	0	0	0	0	0	0
	White	1	1	1	1	1	1	1	1	1	1	1	1	1	1	1	1	1	1
RED	RED (00)	0	0	0	0	0	0	0	0	0	0	0	0	0	0	0	0	0	0
	RED (01)	0	0	0	0	0	1	0	0	0	0	0	0	0	0	0	0	0	0
					
	RED (62)	1	1	1	1	1	0	0	0	0	0	0	0	0	0	0	0	0	0
	RED (63)	1	1	1	1	1	1	0	0	0	0	0	0	0	0	0	0	0	0
GREEN	GREEN (00)	0	0	0	0	0	0	0	0	0	0	0	0	0	0	0	0	0	0
	GREEN (01)	0	0	0	0	0	0	0	0	0	0	0	1	0	0	0	0	0	0
					
	GREEN (62)	0	0	0	0	0	0	1	1	1	1	1	0	0	0	0	0	0	0
	GREEN (63)	0	0	0	0	0	0	1	1	1	1	1	1	0	0	0	0	0	0
BLUE	BLUE (00)	0	0	0	0	0	0	0	0	0	0	0	0	0	0	0	0	0	0
	BLUE (01)	0	0	0	0	0	0	0	0	0	0	0	0	0	0	0	0	0	1
					
	BLUE (62)	0	0	0	0	0	0	0	0	0	0	0	0	1	1	1	1	1	0
	BLUE (63)	0	0	0	0	0	0	0	0	0	0	0	0	1	1	1	1	1	1

3-6. Power Sequence

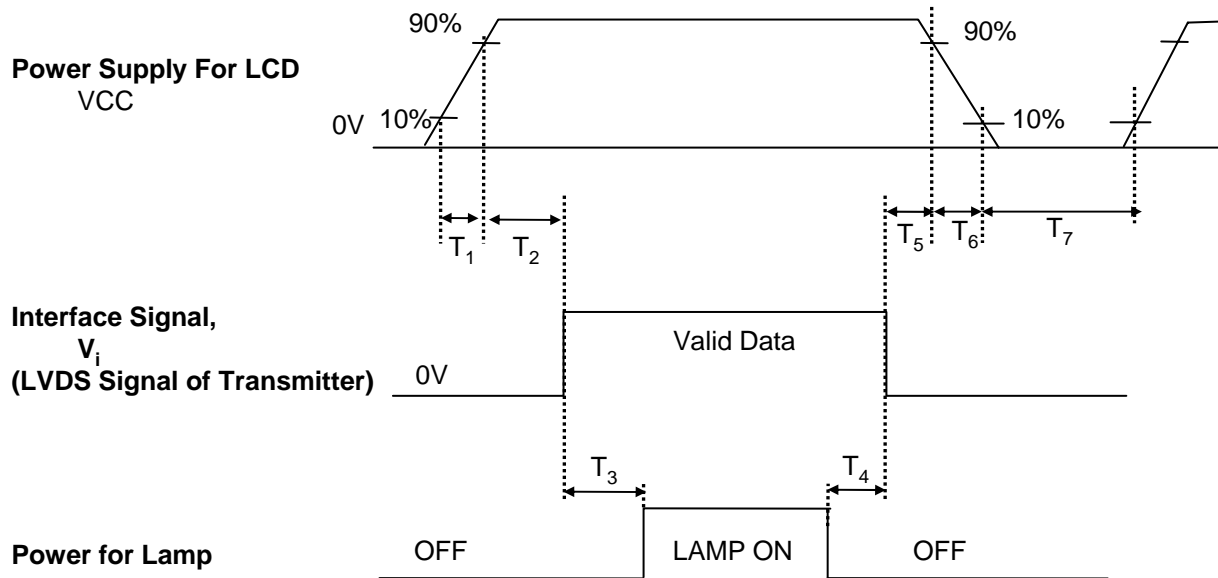

Table 7. POWER SEQUENCE TABLE

Parameter	Value			Unit
	Min.	Typ.	Max.	
T_1	-	-	10	ms
T_2	0	-	50	ms
T_3	200	-	-	ms
T_4	200	-	-	ms
T_5	0	-	50	ms
T_6	0	-	10	ms
T_7	400	-	-	ms

- Notes :
1. Please avoid floating state of interface signal at invalid period.
 2. When the interface signal is invalid, be sure to pull down the power supply for LCD VCC to 0V.
 3. Lamp power must be turn on after power supply for LCD and interface signal are valid.

Product Specification

4. Optical Specification

Optical characteristics are determined after the unit has been 'ON' and stable for approximately 30 minutes in a dark environment at 25°C. The values specified are at an approximate distance 50cm from the LCD surface at a viewing angle of Φ and Θ equal to 0°.

FIG. 1 presents additional information concerning the measurement equipment and method.

FIG. 1 Optical Characteristic Measurement Equipment and Method

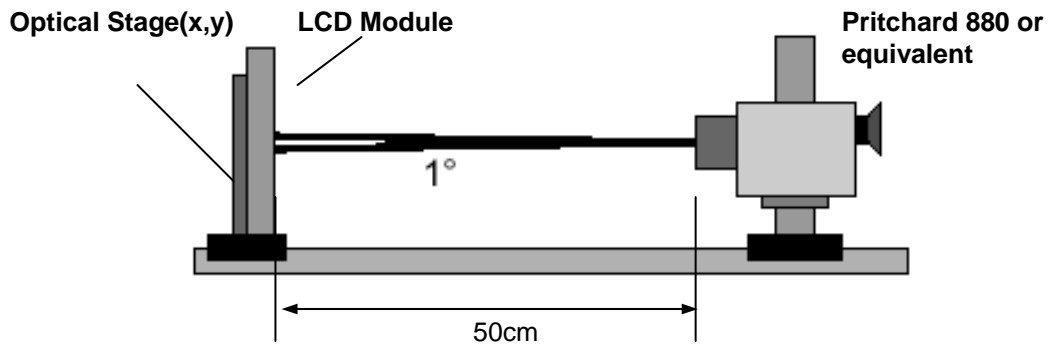

Ta=25°C, VCC=3.3V, fv=60Hz
Dclk= 65MHz, IBL= 6.0mA

Table 8. OPTICAL CHARACTERISTICS

Parameter	Symbol	Values			Units	Notes	
		Min	Typ	Max			
Contrast Ratio	CR	175	250	-		1	
Surface Luminance, white (5P)	L _{WH}	125	150		cd/m ²	2	
Luminance Variation (13P)	δ_{WHITE}	-	-	1.65		3	
Response Time						4	
	Rise Time	T _R	-	10	20	ms	
	Decay Time	T _D	-	20	30	ms	
Color Coordinates						PR650 or equivalent	
RED	RX	0.557	0.587	0.617			
	RY	0.313	0.343	0.373			
GREEN	GX	0.291	0.321	0.351			
	GY	0.500	0.530	0.565			
BLUE	BX	0.129	0.159	0.189			
	BY	0.110	0.140	0.170			
WHITE	WX	0.283	0.313	0.343			
	WY	0.299	0.329	0.359			
Viewing Angle						5	
	x axis, right($\Phi=0^\circ$)	Θ_r	40	45	-		degree
	x axis, left ($\Phi=180^\circ$)	Θ_l	40	45	-		degree
	y axis, up ($\Phi=90^\circ$)	Θ_u	10	15	-		degree
	y axis, down ($\Phi=270^\circ$)	Θ_d	30	35	-		degree
Gray Scale						6	

Product Specification

Notes 1. Contrast Ratio(CR) is defined mathematically as :

$$\text{Contrast Ratio} = \frac{\text{Surface Luminance with all white pixels}}{\text{Surface Luminance with all black pixels}}$$

2. Surface luminance is the average of 5 points across the LCD surface 50cm from the surface with all pixels displaying white. For more information see FIG 1., When $I_{BL}=6.0\text{mA}$.

3. The variation in surface luminance , The Panel total variation (δ_{WHITE}) is determined by measuring L_{ON} at each test position 1 through 13, and then dividing the maximum L_{ON} of 13 points luminance by minimum L_{ON} of 13 points luminance. For more information see FIG 2.

$$\delta_{\text{WHITE}} = \text{Maximum}(L_1, L_2, \dots L_{13}) / \text{Minimum}(L_1, L_2, \dots L_{13})$$

4. Response time is the time required for the display to transition from white to black(RiseTime, Tr_R) and from black to white(Decay Time, Tr_D). For additional information see FIG 3.

5. Viewing angle is the angle at which the contrast ratio is greater than 10. The angles are determined for the horizontal or x axis and the vertical or y axis with respect to the z axis which is normal to the LCD surface. For more information see FIG 4.

6. Gray scale specification

* $f_V=60\text{Hz}$

Gray Level	Luminance [%] (Typ)
L0	0.39
L7	1.20
L15	4.50
L23	11.3
L31	22.0
L39	38.0
L47	57.5
L55	80.0
L63	100

Product Specification

FIG. 2 Luminance

<measuring point for surface luminance>

<measuring point for luminance variation>

POINTS: 5 POINT (1~5)

POINTS: 13 POINTS (1~13)

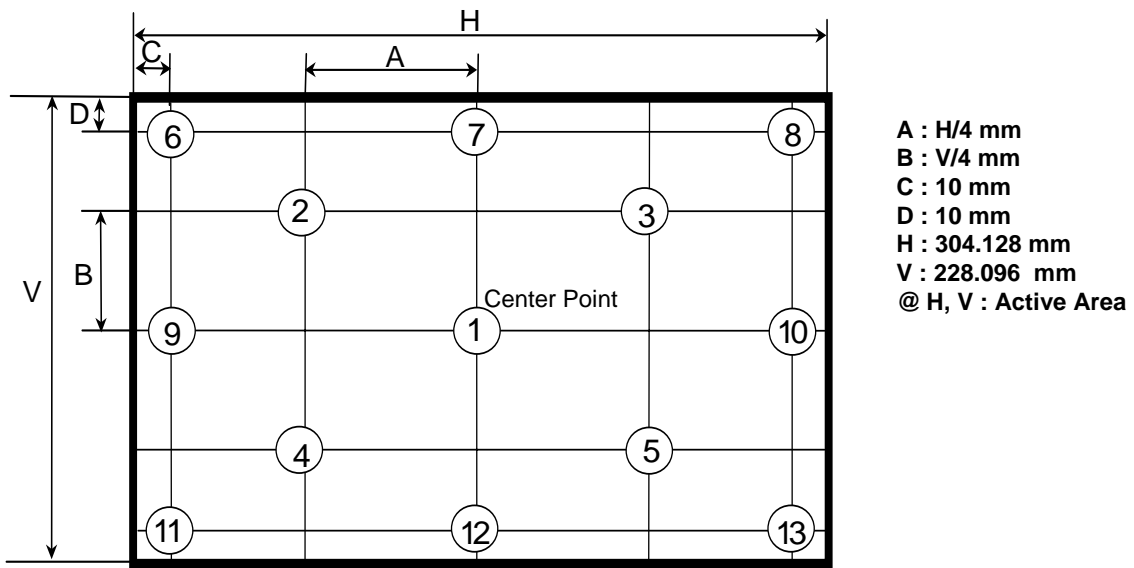
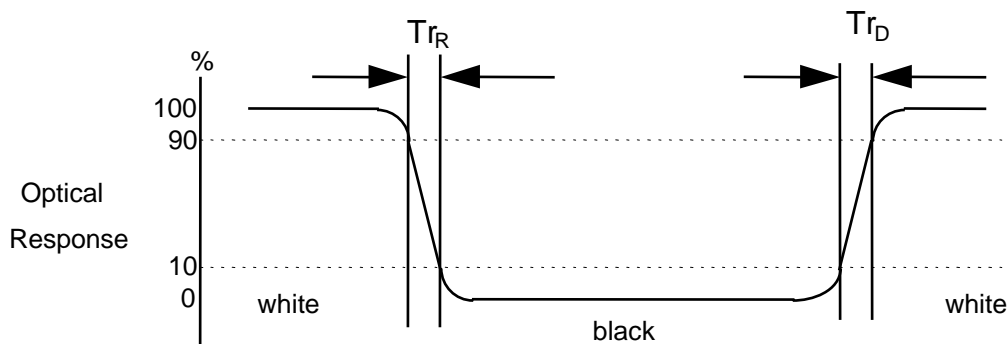

FIG. 3 Response Time

The response time is defined as the following figure and shall be measured by switching the input signal for "black" and "white".



Product Specification

FIG. 4 Viewing angle

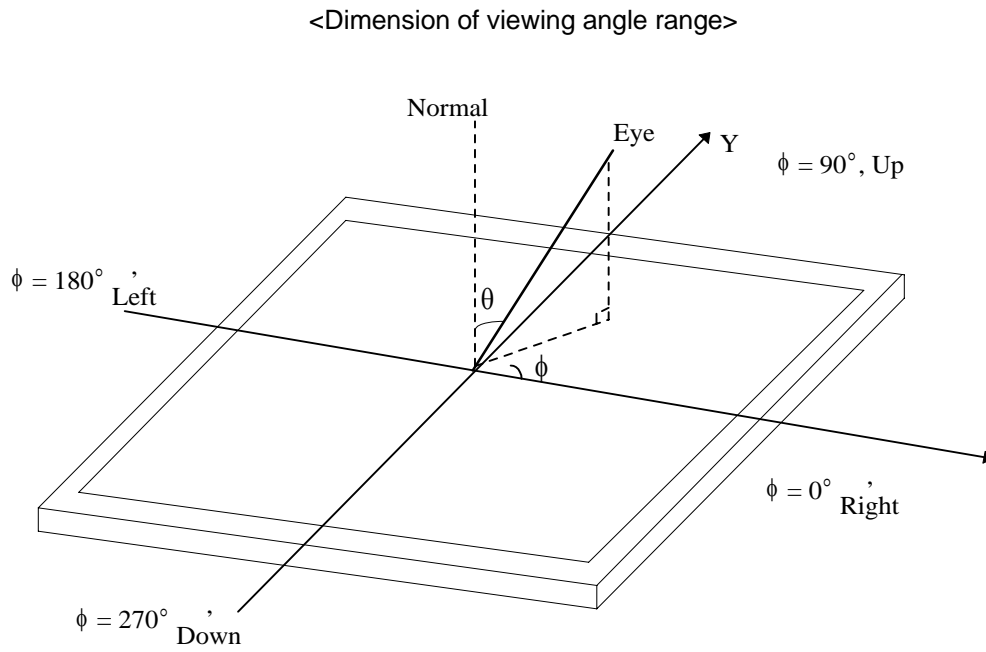

Product Specification

5. Mechanical Characteristics

The contents provide general mechanical characteristics for the model LP150X08. In addition the figures in the next page are detailed mechanical drawing of the LCD.

Outline Dimension	Horizontal	317.3 ± 0.5mm
	Vertical	241.5 ± 0.5mm
	Depth	5.7 ± 0.3mm
Bezel Area	Horizontal	307.5 ± 0.5mm
	Vertical	231.4 ± 0.5mm
Active Display Area	Horizontal	304.128 mm
	Vertical	228.096 mm
Weight	540g (Typ.) 555g (Max.)	
Surface Treatment	Hard coating(3H) Anti-glare treatment of the front polarizer	

Product Specification

<FRONT VIEW>

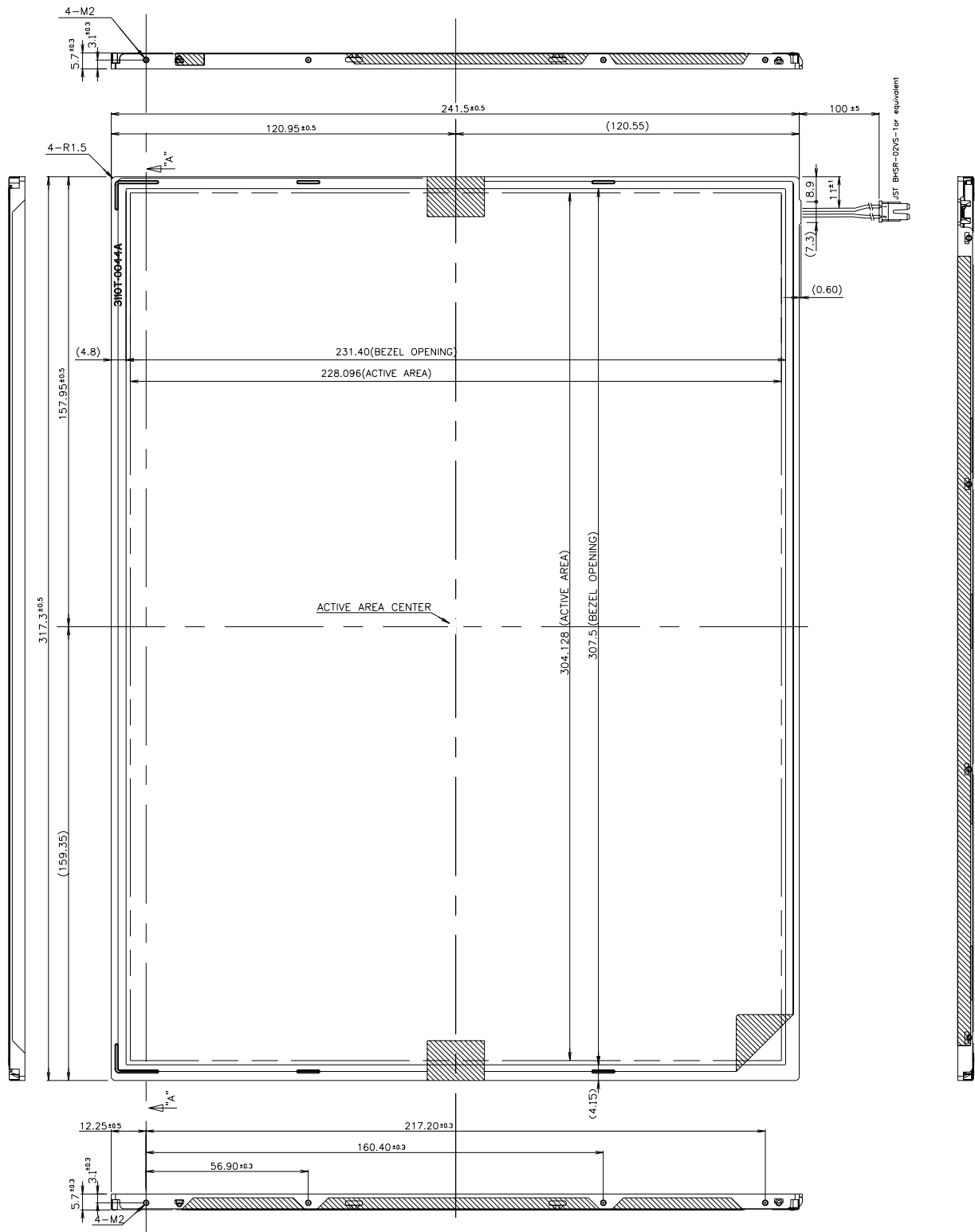

Product Specification

[DETAIL DESCRIPTION OF SIDE MOUNTING SCREW]

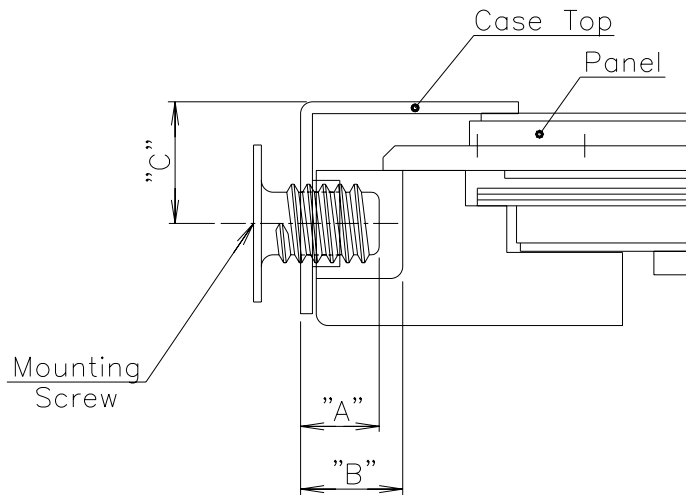

- * Mounting Screw depth
 depth Min. : "A" =2.0
 depth Max : "B" =2.5
- * Mounting hole location : "C" = 3.1(typ.)
- *Torque : 2 kgf.cm(Max)
 (Measurement gauge : torque meter)

Notes : 1. Screw plated through the method of non-electrolytic nickel plating is preferred to reduce possibility that results in vertical and/or horizontal line defect due to the conductive particles from screw surface.

Product Specification

6. Reliability

Environment test condition

No.	Test Item	Conditions
1	High temperature storage test	Ta= 60°C, 240h
2	Low temperature storage test	Ta= -20°C, 240h
3	High temperature operation test	Ta= 50°C, 50%RH, 240h
4	Low temperature operation test	Ta= 0°C, 240h
5	Vibration test (non-operating)	Sine wave, 10 ~ 500 ~ 10Hz, 1.5G, 0.37oct/min 3 axis, 1hour/axis
6	Shock test (non-operating)	Half sine wave, 180G, 2ms one shock of each six faces(I.e. run 180G 2ms for all six faces)
7	Altitude operating storage / shipment	0 ~ 10,000 feet (3,048m) 24Hr 0 ~ 40,000 feet (12,192m) 24Hr

{ Result Evaluation Criteria }

There should be no change which might affect the practical display function when the display quality test is conducted under normal operating condition.

7. International Standards

7-1. Safety

- a) UL 60950, Third Edition, Underwriters Laboratories, Inc., Dated Dec. 11, 2000.
Standard for Safety of Information Technology Equipment, Including Electrical Business Equipment.
- b) CAN/CSA C22.2, No. 60950, Third Edition, Canadian Standards Association, Dec. 1, 2000.
Standard for Safety of Information Technology Equipment, Including Electrical Business Equipment.
- c) EN 60950 : 2000, Third Edition
IEC 60950 : 1999, Third Edition
European Committee for Electrotechnical Standardization(CENELEC)
EUROPEAN STANDARD for Safety of Information Technology Equipment Including Electrical Business Equipment.

7-2. EMC

- a) ANSI C63.4 "Methods of Measurement of Radio-Noise Emissions from Low-Voltage Electrical and Electrical Equipment in the Range of 9kHz to 40GHz. "American National Standards Institute(ANSI), 1992
- b) C.I.S.P.R "Limits and Methods of Measurement of Radio Interface Characteristics of Information Technology Equipment." International Special Committee on Radio Interference.
- c) EN 55022 "Limits and Methods of Measurement of Radio Interface Characteristics of Information Technology Equipment." European Committee for Electrotechnical Standardization.(CENELEC), 1998 (Including A1: 2000)

Product Specification

8. Packing

8-1. Designation of Lot Mark

a) Lot Mark

A	B	C	D	E	F	G	H	I	J	K	L	M
---	---	---	---	---	---	---	---	---	---	---	---	---

A,B,C : SIZE(INCH)

D : YEAR

F : PANEL CODE

H : ASSEMBLY CODE

E : MONTH

G : FACTORY CODE

I,J,K,L,M : SERIAL NO.

Note

1. YEAR

Year	97	98	99	2000	2001	2002	2003	2004	2005	2006	2007
Mark	7	8	9	0	1	2	3	4	5	6	7

2. MONTH

Month	Jan	Feb	Mar	Apr	May	Jun	Jul	Aug	Sep	Oct	Nov	Dec
Mark	1	2	3	4	5	6	7	8	9	A	B	C

3. PANEL CODE

Panel Code	P1 Factory	P2 Factory	P3 Factory	P4 Factory	P5 Factory	Hydis Panel
Mark	1	2	3	4	5	H

4. FACTORY CODE

Factory Code	LPL Gumi	LPL Nanjing
Mark	K	C

5. SERIAL NO.

Year	1 ~ 99999	100000 ~
Mark	00001 ~ 99999	A0001 ~ A9999, , Z9999

b) Location of Lot Mark

Serial NO. is printed on the label. The label is attached to the backside of the LCD module.

This is subject to change without prior notice.

8-2. Packing Form

a) Package quantity in one box : 15 pcs

b) Box Size : 374mm × 329mm × 311mm

9. PRECAUTIONS

Please pay attention to the followings when you use this TFT LCD module.

9-1. MOUNTING PRECAUTIONS

- (1) You must mount a module using holes arranged in four corners or four sides.
- (2) You should consider the mounting structure so that uneven force (ex. Twisted stress) is not applied to the module. And the case on which a module is mounted should have sufficient strength so that external force is not transmitted directly to the module.
- (3) Please attach the surface transparent protective plate to the surface in order to protect the polarizer. Transparent protective plate should have sufficient strength in order to resist external force.
- (4) You should adopt mounting structure to satisfy the temperature specification.
- (5) Acetic acid type and chlorine type materials for the cover case are not desirable because the former generates corrosive gas of attacking the polarizer at high temperature and the latter causes circuit break by electro-chemical reaction.
- (6) Do not touch, push or rub the exposed polarizers with glass, tweezers or anything harder than HB pencil lead. And please do not rub with dust clothes with chemical treatment. Do not touch the surface of polarizer for bare hand or greasy cloth. (Some cosmetics are detrimental to the polarizer.)
- (7) When the surface becomes dusty, please wipe gently with absorbent cotton or other soft materials like chamois soaks with petroleum benzene. Normal-hexane is recommended for cleaning the adhesives used to attach front / rear polarizers. Do not use acetone, toluene and alcohol because they cause chemical damage to the polarizer.
- (8) Wipe off saliva or water drops as soon as possible. Their long time contact with polarizer causes deformations and color fading.
- (9) Do not open the case because inside circuits do not have sufficient strength.

9-2. OPERATING PRECAUTIONS

- (1) The spike noise causes the mis-operation of circuits. It should be lower than following voltage :
 $V = \pm 200\text{mV}$ (Over and under shoot voltage)
- (2) Response time depends on the temperature. (In lower temperature, it becomes longer.)
- (3) Brightness depends on the temperature. (In lower temperature, it becomes lower.)
And in lower temperature, response time (required time that brightness is stable after turned on) becomes longer.
- (4) Be careful for condensation at sudden temperature change. Condensation makes damage to polarizer or electrical contacted parts. And after fading condensation, smear or spot will occur.
- (5) When fixed patterns are displayed for a long time, remnant image is likely to occur.
- (6) Module has high frequency circuits. Sufficient suppression to the electromagnetic interference shall be done by system manufacturers. Grounding and shielding methods may be important to minimize the interference.

9-3. ELECTROSTATIC DISCHARGE CONTROL

Since a module is composed of electronic circuits, it is not strong to electrostatic discharge. Make certain that treatment persons are connected to ground through wrist band etc. And don't touch interface pin directly.

9-4. PRECAUTIONS FOR STRONG LIGHT EXPOSURE

Strong light exposure causes degradation of polarizer and color filter.

9-5. STORAGE

When storing modules as spares for a long time, the following precautions are necessary.

- (1) Store them in a dark place. Do not expose the module to sunlight or fluorescent light. Keep the temperature between 5°C and 35°C at normal humidity.
- (2) The polarizer surface should not come in contact with any other object.
It is recommended that they be stored in the container in which they were shipped.

9-6. HANDLING PRECAUTIONS FOR PROTECTION FILM

- (1) The protection film is attached to the bezel with a small masking tape.
When the protection film is peeled off, static electricity is generated between the film and polarizer. This should be peeled off slowly and carefully by people who are electrically grounded and with well ion-blown equipment or in such a condition, etc.
- (2) When the module with protection film attached is stored for a long time, sometimes there remains a very small amount of glue still on the bezel after the protection film is peeled off.
- (3) You can remove the glue easily. When the glue remains on the bezel surface or its vestige is recognized, please wipe them off with absorbent cotton waste or other soft material like chamois soaked with normal-hexane.

Product Specification

APPENDIX [A] - Enhanced Extended Display Identification Data (EEDID™)

Byte# (decimal)	Byte# (HEX)	Field Name and Comments	Value (HEX)	Value (binary)	
0	00	Header	0 0	0000 0000	Header
1	01		F F	1111 1111	
2	02		F F	1111 1111	
3	03		F F	1111 1111	
4	04		F F	1111 1111	
5	05		F F	1111 1111	
6	06		F F	1111 1111	
7	07		0 0	0000 0000	
8	08	EISA manufacturer code = LGP	3 0	0011 0000	Vender/ Product ID
9	09	Compressed ASCII	F 0	1111 0000	
10	0A	Panel Supplier Reserved -Product code=5XF	5 7	0101 0111	
11	0B	(Hex, LSB first)	0 6	0000 0110	
12	0C	ID(32-bit) serial number = don't care	0 0	0000 0000	
13	0D		0 0	0000 0000	
14	0E		0 0	0000 0000	
15	0F		0 0	0000 0000	
16	10	Week of manufacture = don't care	0 0	0000 0000	
17	11	Year of manufacture = don't care	0 0	0000 0000	
18	12	EDID Structure version # = "1"	0 1	0000 0001	EDID Version/ Revision
19	13	EDID Revision # = "3"	0 3	0000 0011	
20	14	Video input definition = Digital I/p.non TMDS CRGB	8 0	1000 0000	Display Parameter
21	15	Max H image size(cm)= 30.4128cm(30)	1 E	0001 1110	
22	16	Max V image size(cm)= 22.8096cm(23)	1 7	0001 0111	
23	17	Display gamma = 2.2	7 8	0111 1000	
24	18	Feature support(DPMS) = Active off, RGB Color	0 A	0000 1010	Color Characteristic
25	19	Red/Green low Bits (RxRy/GxGy)	7 2	0111 0010	
26	1A	Blue/White Low Bits (BxBY/WxWy)	B 0	1011 0000	
27	1B	Red X Rx = 0.587	9 6	1001 0110	
28	1C	Red Y Ry = 0.343	5 7	0101 0111	
29	1D	Green X Gx = 0.321	5 2	0101 0010	
30	1E	Green Y Gy = 0.530	8 7	1000 0111	
31	1F	Blue X Bx = 0.159	2 8	0010 1000	
32	20	Blue Y By = 0.140	2 3	0010 0011	
33	21	White X Wx = 0.313	5 0	0101 0000	
34	22	White Y Wy = 0.329	5 4	0101 0100	
35	23	Established Timing I	0 0	0000 0000	Established Timings
36	24	Established Timing II	0 0	0000 0000	
37	25	Manufacturer's Timings	0 0	0000 0000	Standard Timing ID
38	26	Standard Timing ID1 (01h if not used)	0 1	0000 0001	
39	27	Standard Timing ID1 (01h if not used)	0 1	0000 0001	
40	28	Standard Timing ID2 (01h if not used)	0 1	0000 0001	
41	29	Standard Timing ID2 (01h if not used)	0 1	0000 0001	
42	2A	Standard Timing ID3 (01h if not used)	0 1	0000 0001	
43	2B	Standard Timing ID3 (01h if not used)	0 1	0000 0001	
44	2C	Standard Timing ID4 (01h if not used)	0 1	0000 0001	
45	2D	Standard Timing ID4 (01h if not used)	0 1	0000 0001	
46	2E	Standard Timing ID5 (01h if not used)	0 1	0000 0001	
47	2F	Standard Timing ID5 (01h if not used)	0 1	0000 0001	
48	30	Standard Timing ID6 (01h if not used)	0 1	0000 0001	
49	31	Standard Timing ID6(01h if not used)	0 1	0000 0001	
50	32	Standard Timing ID7(01h if not used)	0 1	0000 0001	
51	33	Standard Timing ID7 (01h if not used)	0 1	0000 0001	
52	34	Standard Timing ID8 (01h if not used)	0 1	0000 0001	
53	35	Standard Timing ID8 (01h if not used)	0 1	0000 0001	
54	36	Detailed Timing Descriptor #1	6 4	0110 0100	
55	37	1024X768 @ 60 Hz mode : pixel clock = 65.00 MHz	1 9	0001 1001	
56	38	Horizontal Active = 1024 pixels	0 0	0000 0000	
57	39	Horizontal Blanking = 320 pixels	4 0	0100 0000	
58	3A	Horizontal Active : Horizontal Blanking	4 1	0100 0001	
59	3B	Vertical Active = 768 lines	0 0	0000 0000	
60	3C	Vertical Blanking = 38 lines	2 6	0010 0110	
61	3D	Vertical Active : Vertical Blanking	3 0	0011 0000	
62	3E	Horizontal Sync. Offset = 24 pixels	1 8	0001 1000	
63	3F	Horizontal Sync. Pulse Width = 136 pixels	8 8	1000 1000	
64	40	Vertical Sync. Offset = 3 lines : Sync. Width = 6 lines	3 6	0011 0110	

Product Specification

Byte# (decimal)	Byte# (HEX)	Field Name and Comments	Value (HEX)	Value (binary)	
65	41	Horizontal Vertical Sync. Offset/Width upper 2bits	0 0	0000 0000	Detailed Timing Description #1
66	42	Horizontal Image Size = 304.128 mm(304)	3 0	0011 0000	
67	43	Vertical Image Size = 228.096 mm(228)	E 4	1110 0100	
68	44	Horizontal & Vertical Image Size	1 0	0001 0000	
69	45	Horizontal Border = 0	0 0	0000 0000	
70	46	Vertical Border = 0	0 0	0000 0000	
71	47	Non-interlaced,Normal display,no stereo,Digital separate sync,H/V pol	1 8	0001 1000	
72	48	Detailed Timing Descriptor #2 was not used	0 0	0000 0000	Detailed Timing Description #2
73	49		0 0	0000 0000	
74	4A		0 0	0000 0000	
75	4B		0 0	0000 0000	
76	4C		0 0	0000 0000	
77	4D		0 0	0000 0000	
78	4E		0 0	0000 0000	
79	4F		0 0	0000 0000	
80	50		0 0	0000 0000	
81	51		0 0	0000 0000	
82	52		0 0	0000 0000	
83	53		0 0	0000 0000	
84	55		0 0	0000 0000	
85	55		0 0	0000 0000	
86	56		0 0	0000 0000	
87	57		0 0	0000 0000	
88	58		0 0	0000 0000	
89	59		0 0	0000 0000	
90	5A	Detailed Timing Descriptor #3	0 0	0000 0000	Detailed Timing Description #3
91	5B		0 0	0000 0000	
92	5C	ASCII Data String Tag (Supplier Name)	0 0	0000 0000	
93	5D		0 0	0000 0000	
94	5E		0 0	0000 0000	
95	5F		[L]	4 C	
96	60	[G]	4 7	0100 0111	
97	61	[P]	5 0	0101 0000	
98	62	[h]	6 8	0110 1000	
99	63	[i]	6 9	0110 1001	
100	64	[l]	6 C	0110 1100	
101	65	[i]	6 9	0110 1001	
102	66	[p]	7 0	0111 0000	
103	67	[s]	7 3	0111 0011	
104	68	[L]	4 C	0100 1100	
105	69	[C]	4 3	0100 0011	
106	6A	[D]	4 4	0100 0100	
107	6B	[^] Line Feed	0 A	0000 1010	
108	6C	Detailed Timing Descriptor #4	0 0	0000 0000	Detailed Timing Description #4
109	6D		0 0	0000 0000	
110	6E	ASCII Data String Tag (Supplier P/N)	0 0	0000 0000	
111	6F		0 0	0000 0000	
112	70		0 0	0000 0000	
113	71		[L]	4 C	
114	72	[P]	5 0	0101 0000	
115	73	[1]	3 1	0011 0001	
116	74	[5]	3 5	0011 0101	
117	75	[0]	3 0	0011 0000	
118	76	[X]	5 8	0101 1000	
119	77	[0]	3 0	0011 0000	
120	78	[8]	3 8	0011 1000	
121	79	[-]	2 D	0010 1101	
122	7A	[A]	4 1	0100 0001	
123	7B	[5]	3 5	0011 0101	
124	7C		0 0	0000 0000	
125	7D		0 0	0000 0000	
126	7E	Extension flag = 00	0 0	0000 0000	Extension Flag
127	7F	Checksum	2 3	0010 0011	Checksum