

mass integrated

global part distribution • product lifecycle partner
excess inventory management • value-ad service provider



Data sheet provided by Mass Integrated

massintegrated.com • displayalliance.com

Please call +1.978.465.6190
Email: sales@massintegrated.com



ISO 9001: 2008

Mass Integrated complies with all DMCA takedown notices. Please send a formal DMCA Takedown Notice to Mass Integrated Systems, Inc. • 18 Henry Graf Jr. Road, Unit 1 • Newburyport, MA 01950.

SPECIFICATION FOR APPROVAL

() Preliminary Specification

(●) Final Specification

Title	17.3" FHD TFT LCD
-------	-------------------

BUYER	SONY
MODEL	

SUPPLIER	LG Display Co., Ltd.
*MODEL	LP173WF1
Suffix	TLC1

*When you obtain standard approval,
please use the above model name without suffix

APPROVED BY	SIGNATURE
/	_____
/	_____
/	_____

Please return 1 copy for your confirmation with your signature and comments.

APPROVED BY	SIGNATURE
H. S. Kim / S.Manager	_____
REVIEWED BY	
M. J. Lee / Manager	_____
PREPARED BY	
J. Y. Lee / Engineer S. W. Kim / Engineer	_____

**Product Engineering Dept.
LG Display Co., Ltd**

Product Specification

Contents

No	ITEM	Page
	COVER	1
	CONTENTS	2
	RECORD OF REVISIONS	3
1	GENERAL DESCRIPTION	4
2	ABSOLUTE MAXIMUM RATINGS	5
3	ELECTRICAL SPECIFICATIONS	
3-1	ELECTRICAL CHARACTERISTICS	6
3-2	INTERFACE CONNECTIONS	8
3-3	LVDS SIGNAL TIMING SPECIFICATIONS	9
3-4	SIGNAL TIMING SPECIFICATIONS	11
3-5	SIGNAL TIMING WAVEFORMS	11
3-6	COLOR INPUT DATA REFERNECE	12
3-7	POWER SEQUENCE	13
4	OPTICAL SFECIFICATIONS	14
5	MECHANICAL CHARACTERISTICS	17
6	RELIABLITY	27
7	INTERNATIONAL STANDARDS	
7-1	SAFETY	28
7-2	EMC	28
7-3	Environment	28
8	PACKING	
8-1	DESIGNATION OF LOT MARK	29
8-2	PACKING FORM	29
9	PRECAUTIONS	30-31

Product Specification

1. General Description

The LP173WF1 is a Color Active Matrix Liquid Crystal Display with an integral LED backlight system. The matrix employs a-Si Thin Film Transistor as the active element. It is a transmissive type display operating in the normally white mode. This TFT-LCD has 17.3 inches diagonally measured active display area with FHD resolution (1920 horizontal by 1080 vertical pixel array). Each pixel is divided into Red, Green and Blue sub-pixels or dots which are arranged in vertical stripes. Gray scale or the brightness of the sub-pixel color is determined with a 6-bit gray scale signal for each dot, thus, presenting a palette of more than 262,144 colors. The LP173WF1 has been designed to apply the interface method that enables low power, high speed, low EMI. The LP173WF1 is intended to support applications where thin thickness, low power are critical factors and graphic displays are important. In combination with the vertical arrangement of the sub-pixels, the LP173WF1 characteristics provide an excellent flat display for office automation products such as Notebook PC.

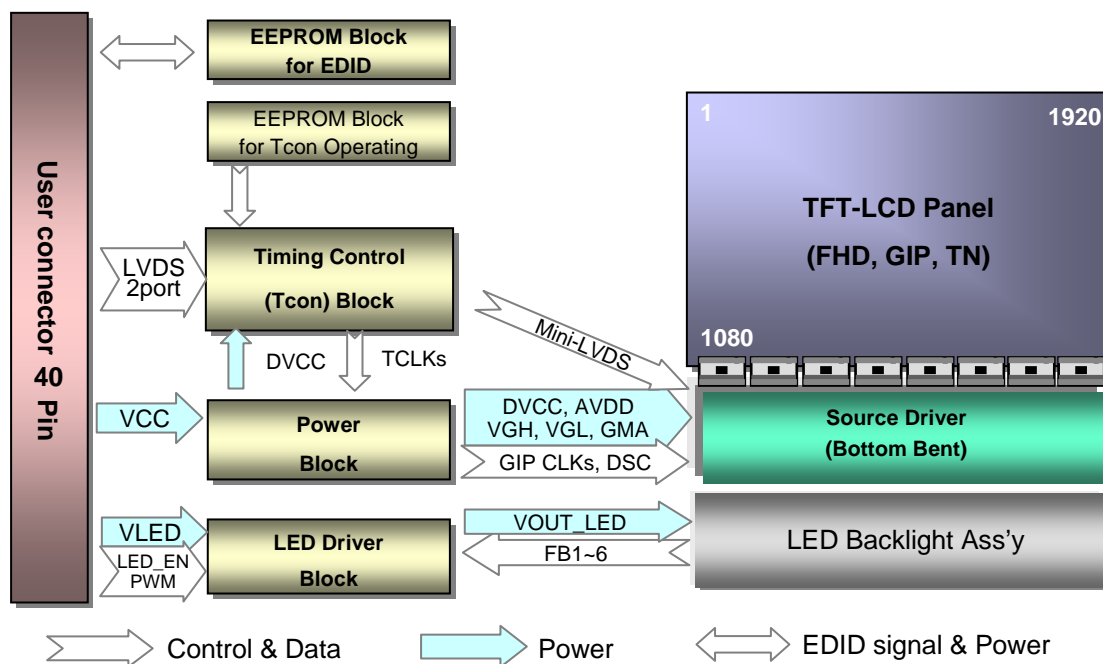

General Features

Active Screen Size	17.3 inches diagonal
Outline Dimension	398.1(H, Typ.) × 232.8(V, Typ.) × 6.0(D, Max.) mm
Pixel Pitch	0.1989 X 0.1989 mm
Pixel Format	1920 horiz. by 1080 vert. Pixels RGB strip arrangement
Color Depth	6-bit, 262,144 colors
Luminance, White	200 cd/m ² (Typ., @ I _{LED} =22mA)
Power Consumption	Total 8.5W(Typ.) Logic : 2.0W (Typ.@ Mosaic), B/L : 6.5W (Typ.@ VLED 12V)
Weight	580g (Max.)
Display Operating Mode	Transmissive mode, normally white
Surface Treatment	Glare treatment (3H) of the front Polarizer
RoHS Compliance	Yes
BFR / PVC / As Free	Yes for all

Product Specification

2. Absolute Maximum Ratings

The following are maximum values which, if exceeded, may cause faulty operation or damage to the unit.

Table 1. ABSOLUTE MAXIMUM RATINGS

Parameter	Symbol	Values		Units	Notes
		Min	Max		
Power Input Voltage	VCC	-0.3	4.0	Vdc	at 25 ± 5°C
Operating Temperature	TOP	0	50	°C	1
Storage Temperature	HST	-20	60	°C	1
Operating Ambient Humidity	HOA	10	90	%RH	1
Storage Humidity	HST	10	90	%RH	1

Note : 1. Temperature and relative humidity range are shown in the figure below.
Wet bulb temperature should be 39°C Max, and no condensation of water.

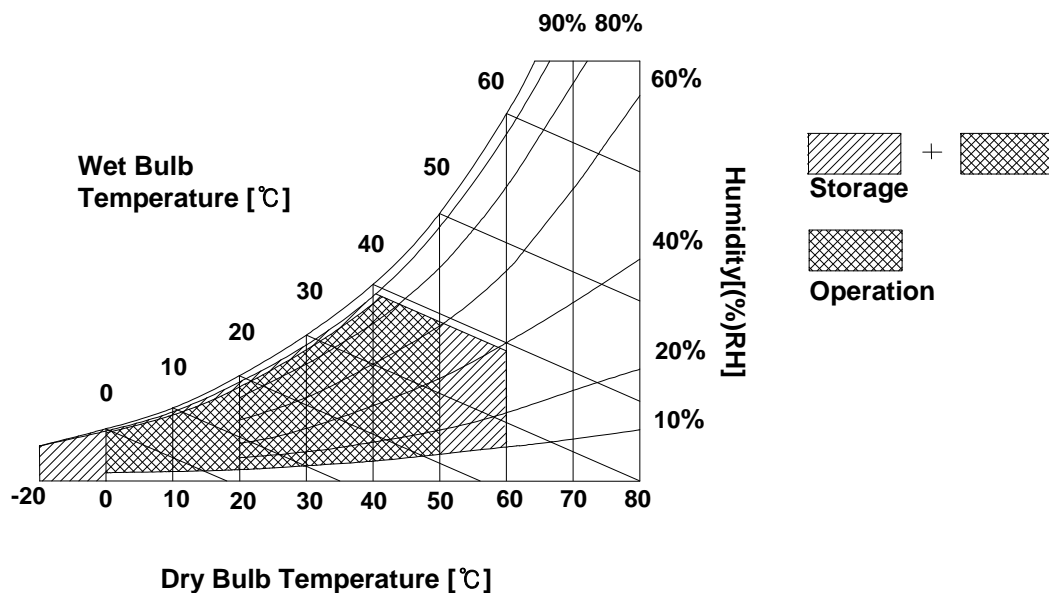

Product Specification

3. Electrical Specifications

3-1. Electrical Characteristics

The LP173WF1 requires two power inputs. The first logic is employed to power the LCD electronics and to drive the TFT array and liquid crystal. The second backlight is the input about LED BL.with LED Driver.

Table 2. ELECTRICAL CHARACTERISTICS

Parameter	Symbol	Values			Unit	Notes
		Min	Typ	Max		
LOGIC :						
Power Supply Input Voltage	V _{CC}	3.0	3.3	3.6	V	1
Power Supply Input Current	I _{CC}	-	600	680	mA	2
Power Consumption	P _{CC}	-	1.98	2.24	W	2
Power Supply Inrush Current	I _{CC_P}	-	770	900	mA	4
LVDS Impedance	Z _{LVDS}	90	100	110	Ω	5
BACKLIGHT : (with LED Driver)						
LED Power Input Voltage	V _{LED}	7.5	12.0	21.0	V	6
LED Power Input Current	I _{LED}	-	540	565	mA	7
LED Power Consumption	P _{LED}	-	6.48	6.78	W	7
LED Power Inrush Current	I _{LED_P}	-	450	550	mA	8
PWM Duty Ratio		5	-	100	%	9
PWM Jitter	-	0	-	0.2	%	10
PWM Impedance	Z _{PWM}	20	40	60	kΩ	
PWM Frequency	F _{PWM}	200	-	1000	Hz	11
PWM High Level Voltage	V _{PWM_H}	3.0	-	5.3	V	
PWM Low Level Voltage	V _{PWM_L}	0	-	0.5	V	
LED_EN Impedance	Z _{PWM}	20	40	60	kΩ	
LED_EN High Voltage	V _{LED_EN_H}	3.0	-	5.3	V	
LED_EN Low Voltage	V _{LED_EN_L}	0	-	0.5	V	
Life Time		12,000	-	-	Hrs	12

Product Specification

3-2. Interface Connections

This LCD employs two interface connections, a 40 pin connector is used for the module electronics interface and the other connector is used for the integral backlight system.

The electronics interface connector is a model 20455-040E manufactured by UJU & LSMtron

Table 3. MODULE CONNECTOR PIN CONFIGURATION (CN1)

Pin	Symbol	Description	Notes
1	DIAG_LOOP	Buyer's Test loop to 34pin	[Interface Chip] 1. LCD : SW, SW0617(LCD Controller) Including LVDS Receiver. 2. System : SiWLVDSDRx or equivalent * Pin to Pin compatible with LVDS [Connector] UJU IS050-L40B-C10 LSMtron GT05Q-40S-H10 or equivalent [Mating Connector] 20345-#40E-## series or equivalent [Connector pin arrangement]
2	VDD	Power Supply (3.3V typ.)	
3	VDD	Power Supply (3.3V typ.)	
4	V EEDID	DDC 3.3V power	
5	BIST	Panel Self Test	
6	CLK EEDID	DDC clock / SMBus clock	
7	DATA EEDLD	DDC data / SMBus data	
8	Odd_Rin0-	- LVDS differential data input (R0-R5,G0)	
9	Odd_Rin0+	+ LVDS differential data input (R0-R5,G0)	
10	GND	Ground	
11	Odd_Rin1-	- LVDS differential data input (G1-G5,B0-B1)	
12	Odd_Rin1+	+ LVDS differential data input (G1-G5,B0-B1)	
13	GND	Ground	
14	Odd_Rin2-	- LVDS differential data input (B2-B5,HS,VS,DE)	
15	Odd_Rin2+	+ LVDS differential data input (B2-B5,HS,VS,DE)	
16	GND	Ground	
17	Odd_ClkIN-	- LVDS differential clock input	
18	Odd_ClkIN+	+ LVDS differential clock input	
19	GND	No Connection	
20	Even Rin0-	- LVDS differential data input (R0-R5,G0)	
21	Even Rin0+	+ LVDS differential data input (R0-R5,G0)	
22	GND	Ground	
23	Even Rin1-	- LVDS differential data input (G1-G5,B0-B1)	
24	Even Rin1+	+ LVDS differential data input (G1-G5,B0-B1)	
25	GND	Ground	
26	Even Rin2-	- LVDS differential data input (B2-B5,HS,VS,DE)	
27	Even Rin2+	+ LVDS differential data input (B2-B5,HS,VS,DE)	
28	GND	Ground	
29	Even ClkIN-	- LVDS differential clock input	
30	Even ClkIN+	+ LVDS differential clock input	
31	GND	LED power return	
32	GND	LED power return	
33	GND	LED power return	
34	DIAG_LOOP	Buyer's Test loop to 1pin	
35	PWM	PWM for luminance control	
36	LED_EN	BL On/Off	
37	NC	No Connection.	
38	VLED	7V-21V LED power	
39	VLED	7V-21V LED power	
40	VLED	7V-21V LED power	

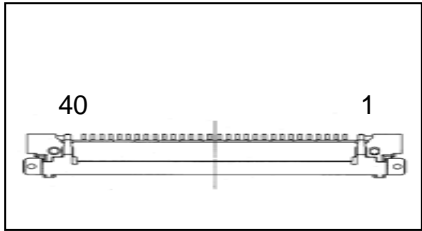

3-3. LVDS Signal Timing Specifications

3-3-1. DC Specification

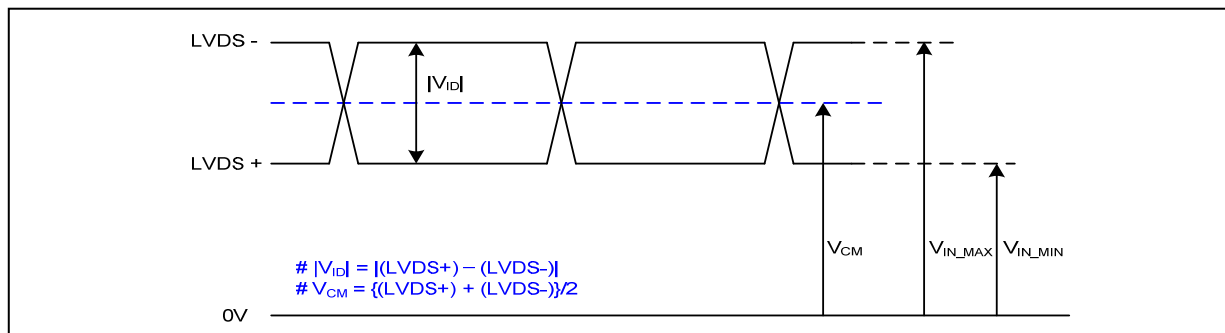

Description	Symbol	Min	Max	Unit	Notes
LVDS Differential Voltage	V _{ID}	100	600	mV	-
LVDS Common mode Voltage	V _{CM}	0.6	1.8	V	-
LVDS Input Voltage Range	V _{IN}	0.3	2.1	V	-

3-3-2. AC Specification

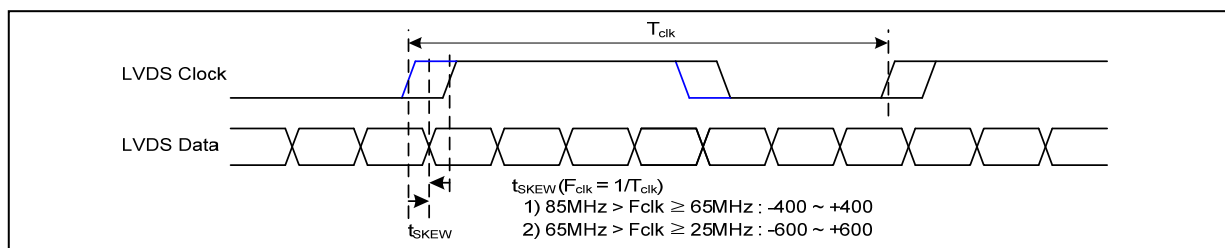

Description	Symbol	Min	Max	Unit	Notes
LVDS Clock to Data Skew Margin	t _{SKEW}	- 400	+ 400	ps	85MHz > F _{clk} ≥ 65MHz
	t _{SKEW}	- 600	+ 600	ps	65MHz > F _{clk} ≥ 25MHz
LVDS Clock to Clock Skew Margin (Even to Odd)	t _{SKEW_EO}	- 1/7	+ 1/7	T _{clk}	-
Maximum deviation of input clock frequency during SSC	F _{DEV}	-	± 3	%	-
Maximum modulation frequency of input clock during SSC	F _{MOD}	-	200	KHz	-

Product Specification

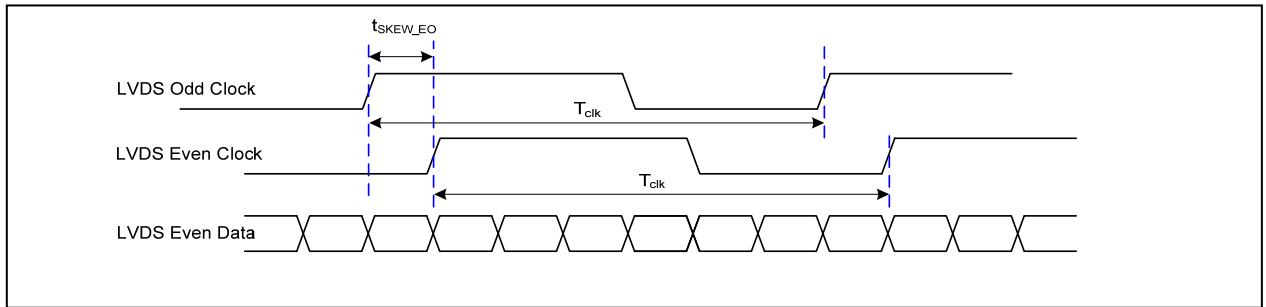

< Clock skew margin between channel >

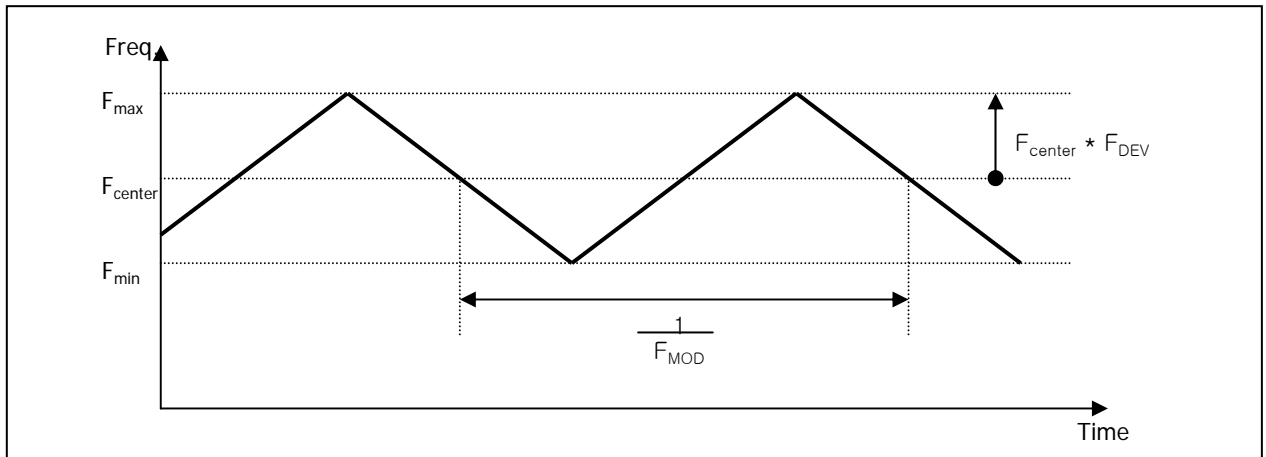

< Spread Spectrum >

3-3-3. Data Format

1) LVDS 2 Port

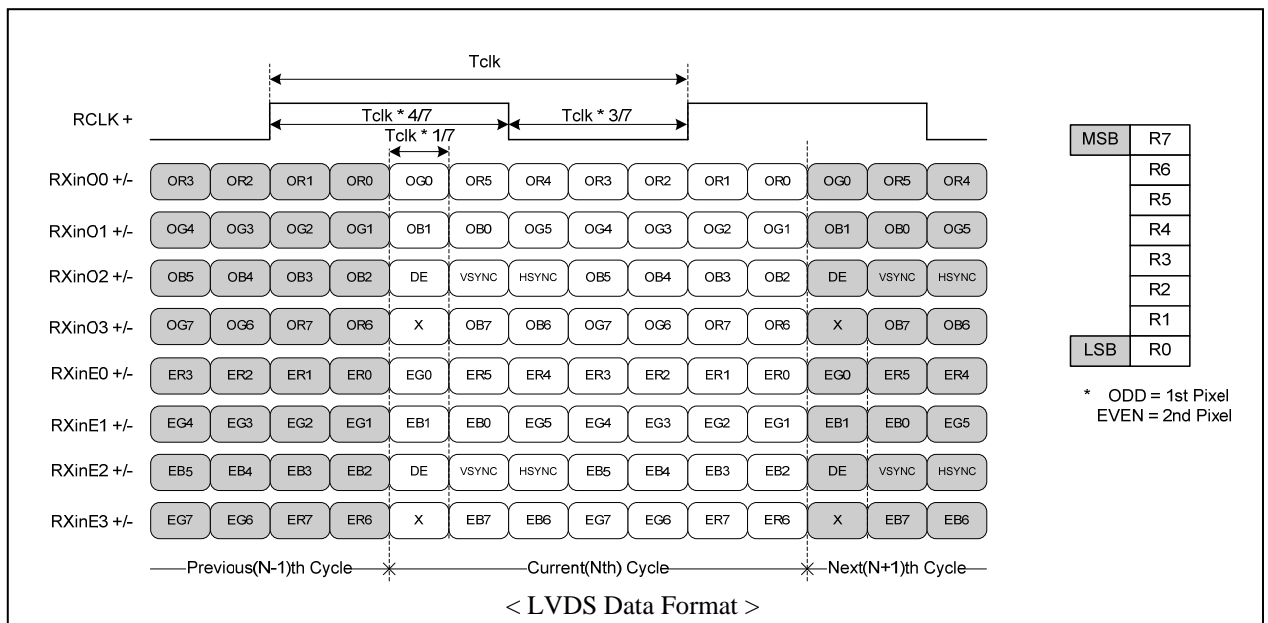

< LVDS Data Format >

Product Specification

3-4. Signal Timing Specifications

This is the signal timing required at the input of the User connector. All of the interface signal timing should be satisfied with the following specifications and specifications of LVDS Tx/Rx for its proper operation.

Table 5. TIMING TABLE (The Standard of 60Hz Refresh Rate)

ITEM	Symbol		Min	Typ	Max	Unit	Note
DCLK	Frequency	f _{CLK}	71.2	74.9	78.6	MHz	2port
Hsync	Period	t _{HP}	1086	1138	1190	f _{CLK}	2port
	Blanking Total	t _{HFP} + t _{WH} + t _{HBP}	126	178	230		
	Width-Active	t _{WHA}	960	960	960		
Vsync	Period	t _{VP}	1093	1097	1101	t _{HP}	
	Blanking Total	t _{VFP} + t _{WV} + t _{VBP}	13	17	21		
	Width-Active	t _{WVA}	1080	1080	1080		

Note1) Tentative Timing Table for 50Hz Refresh Rate

ITEM	Symbol		Min	Typ	Max	Unit	Note
DCLK	Frequency	f _{CLK}	59.3	62.4	65.5	MHz	2port
Hsync	Period	t _{HP}	1086	1138	1190	f _{CLK}	2port
	Blanking Total	t _{HFP} + t _{WH} + t _{HBP}	126	178	230		
	Width-Active	t _{WHA}	960	960	960		
Vsync	Period	t _{VP}	1093	1097	1101	t _{HP}	
	Blanking Total	t _{VFP} + t _{WV} + t _{VBP}	13	17	21		
	Width-Active	t _{WVA}	1080	1080	1080		

Note 2) Tentative Timing Table for 40Hz Refresh Rate (Note 1)

ITEM	Symbol		Min	Typ	Max	Unit	Note
DCLK	Frequency	f _{CLK}	47.5	49.9	52.4	MHz	2port
Hsync	Period	t _{HP}	1086	1138	1190	f _{CLK}	2port
	Blanking Total	t _{HFP} + t _{WH} + t _{HBP}	126	178	230		
	Width-Active	t _{WHA}	960	960	960		
Vsync	Period	t _{VP}	1093	1097	1101	t _{HP}	
	Blanking Total	t _{VFP} + t _{WV} + t _{VBP}	13	17	21		
	Width-Active	t _{WVA}	1080	1080	1080		

Note 2) This model don't guarantee the image quality about flicker level and gate block/line dim at power saving mode with 50Hz or 40 Hz Refresh rate.

Product Specification

3-6. Color Input Data Reference

The brightness of each primary color (red, green and blue) is based on the 6-bit gray scale data input for the color ; the higher the binary input, the brighter the color. The table below provides a reference for color versus data input.

Table 6. COLOR DATA REFERENCE

Color		Input Color Data																	
		RED						GREEN						BLUE					
		MSB			LSB			MSB			LSB			MSB			LSB		
		R 5	R 4	R 3	R 2	R 1	R 0	G 5	G 4	G 3	G 2	G 1	G 0	B 5	B 4	B 3	B 2	B 1	B 0
Basic Color	Black	0	0	0	0	0	0	0	0	0	0	0	0	0	0	0	0	0	0
	Red	1	1	1	1	1	1	0	0	0	0	0	0	0	0	0	0	0	0
	Green	0	0	0	0	0	0	1	1	1	1	1	1	0	0	0	0	0	0
	Blue	0	0	0	0	0	0	0	0	0	0	0	0	1	1	1	1	1	1
	Cyan	0	0	0	0	0	0	1	1	1	1	1	1	1	1	1	1	1	1
	Magenta	1	1	1	1	1	1	0	0	0	0	0	0	1	1	1	1	1	1
	Yellow	1	1	1	1	1	1	1	1	1	1	1	1	0	0	0	0	0	0
	White	1	1	1	1	1	1	1	1	1	1	1	1	1	1	1	1	1	1
RED	RED (00)	0	0	0	0	0	0	0	0	0	0	0	0	0	0	0	0	0	0
	RED (01)	0	0	0	0	0	1	0	0	0	0	0	0	0	0	0	0	0	0
					
	RED (62)	1	1	1	1	1	0	0	0	0	0	0	0	0	0	0	0	0	0
	RED (63)	1	1	1	1	1	1	0	0	0	0	0	0	0	0	0	0	0	0
GREEN	GREEN (00)	0	0	0	0	0	0	0	0	0	0	0	0	0	0	0	0	0	0
	GREEN (01)	0	0	0	0	0	0	0	0	0	0	0	1	0	0	0	0	0	0
					
	GREEN (62)	0	0	0	0	0	0	1	1	1	1	1	0	0	0	0	0	0	0
	GREEN (63)	0	0	0	0	0	0	1	1	1	1	1	1	0	0	0	0	0	0
BLUE	BLUE (00)	0	0	0	0	0	0	0	0	0	0	0	0	0	0	0	0	0	0
	BLUE (01)	0	0	0	0	0	0	0	0	0	0	0	0	0	0	0	0	0	1
					
	BLUE (62)	0	0	0	0	0	0	0	0	0	0	0	0	1	1	1	1	1	0
	BLUE (63)	0	0	0	0	0	0	0	0	0	0	0	0	1	1	1	1	1	1

Product Specification

3-7. Power Sequence

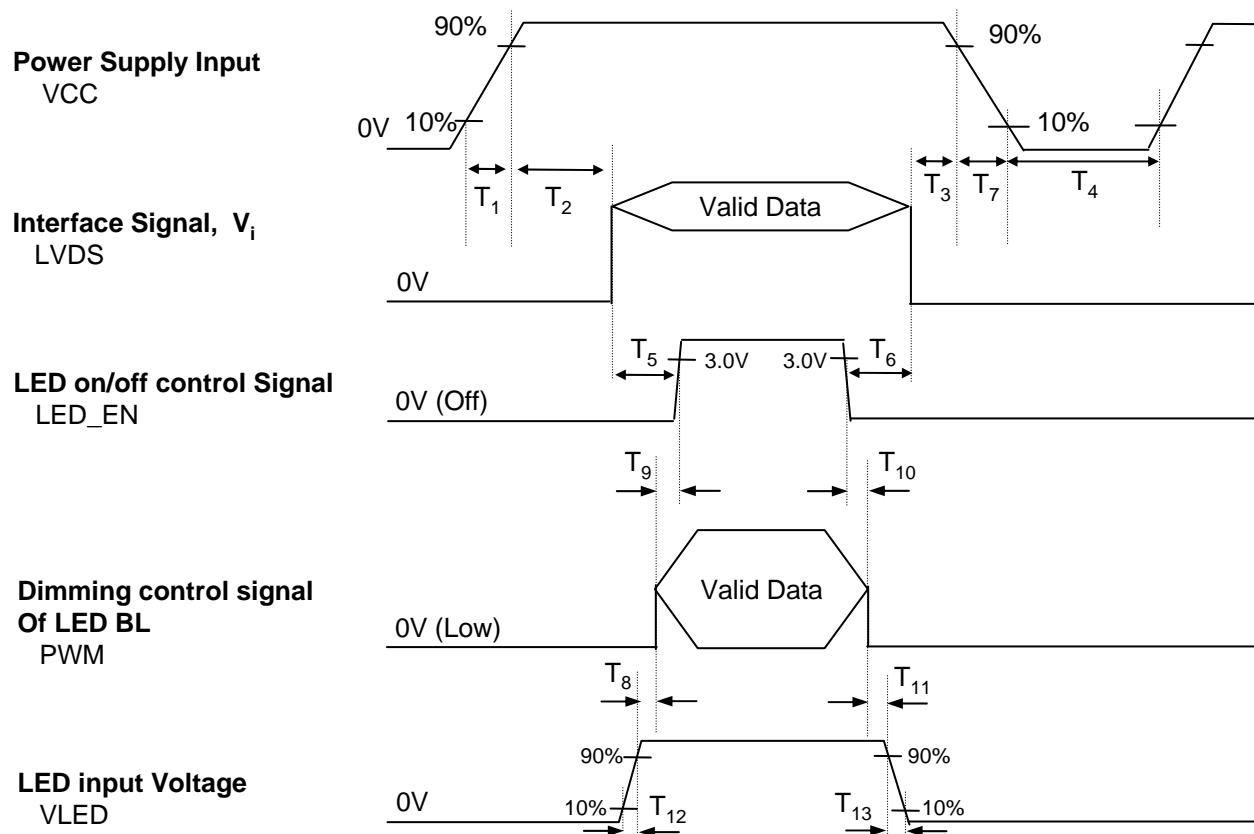

Table 6. POWER SEQUENCE TABLE

Logic Parameter	Value			Units	LED Parameter	Value			Units
	Min.	Typ.	Max.			Min.	Typ.	Max.	
T ₁	0.5	-	10	ms	T ₈	10	-	-	ms
T ₂	0	-	50	ms	T ₉	0	-	-	ms
T ₃	0	-	50	ms	T ₁₀	0	-	-	ms
T ₄	400	-	-	ms	T ₁₁	10	-	-	ms
T ₅	200	-	-	ms	T ₁₂	0.5	-	-	ms
T ₆	200	-	-	ms	T ₁₃	0	-	5000	ms
T ₇	3	-	10	ms					

Note)

1. Do not insert the mating cable when system turn on.
2. Valid Data have to meet "3-3. LVDS Signal Timing Specifications"
3. LVDS, LED_EN and PWM need to pull-down condition on invalid status.
4. LGD recommend the rising sequence of VLED after the Vcc and valid status of LVDS turn on.

Product Specification

4. Optical Specification

Optical characteristics are determined after the unit has been 'ON' and stable for approximately 20 minutes in a dark environment at 25°C. The values specified are at an approximate distance 50cm from the LCD surface at a viewing angle of Φ and Θ equal to 0°.

FIG. 1 presents additional information concerning the measurement equipment and method.

FIG. 1 Optical Characteristic Measurement Equipment and Method

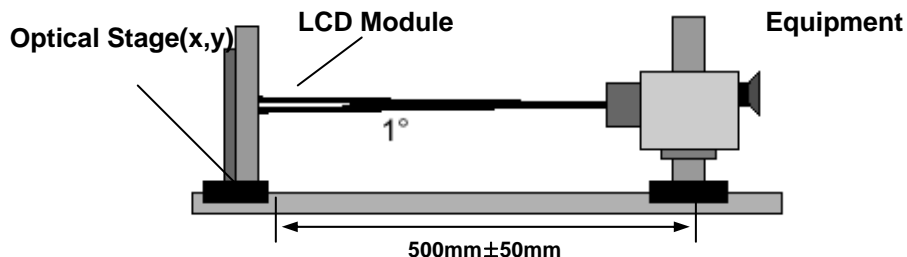

Table 8. OPTICAL CHARACTERISTICS

Ta=25°C, VCC=3.3V, fv=60Hz, f_{CLK}= 97.75MHz, ILED = TBD mA

Parameter	Symbol	Values			Units	Notes
		Min	Typ	Max		
Contrast Ratio	CR	400	500	-		1
Surface Luminance, white	L _{WH}	170	200	-	cd/m ²	2
Luminance Variation	δ_{WHITE}	-	-	35%		3
Response Time	Tr _R + Tr _D	-	8	16	ms	4
Color Coordinates						
RED	RX	0.620	0.650	0.680		
	RY	0.310	0.340	0.370		
GREEN	GX	0.290	0.320	0.350		
	GY	0.606	0.636	0.666		
BLUE	BX	0.120	0.150	0.180		
	BY	0.030	0.060	0.090		
WHITE	WX	0.283	0.313	0.343		
	WY	0.299	0.329	0.359		
Viewing Angle						5
x axis, right($\Phi=0^\circ$)	Θ_r	40	-	-	degree	
x axis, left ($\Phi=180^\circ$)	Θ_l	40	-	-	degree	
y axis, up ($\Phi=90^\circ$)	Θ_u	10	-	-	degree	
y axis, down ($\Phi=270^\circ$)	Θ_d	30	-	-	degree	
Gray Scale						6
Color Gamut	C/G	-	72	-	%	

Product Specification

Note)

1. Contrast Ratio(CR) is defined mathematically as

$$\text{Contrast Ratio} = \frac{\text{Surface Luminance with all white pixels}}{\text{Surface Luminance with all black pixels}}$$

2. Surface luminance is the average of 5 point across the LCD surface 50cm from the surface with all pixels displaying white. For more information see FIG 1.

$$\text{LWH} = \text{Average}(\text{L1}, \text{L2}, \dots \text{L5})$$

 3. The variation in surface luminance , The panel total variation (δ WHITE) is determined by measuring LN at each test position 1 through 13 and then defined as followed numerical formula.
 For more information see FIG 2.

$$\delta \text{ WHITE} (= \frac{\text{Maximum}(\text{L1}, \text{L2}, \dots \text{L13}) - \text{Minimum}(\text{L1}, \text{L2}, \dots \text{L13})}{\text{Maximum}(\text{L1}, \text{L2}, \dots \text{L13})} * 100(\%))$$

4. Response time is the time required for the display to transition from white to black (rise time, TrR) and from black to white(Decay Time, TrD). For additional information see FIG 3.

5. Viewing angle is the angle at which the contrast ratio is greater than 10. The angles are determined for the horizontal or x axis and the vertical or y axis with respect to the z axis which is normal to the LCD surface. For more information see FIG 4.

6. Gray scale specification

* fV = 60Hz

Gray Level	Luminance [%] (Typ)
L0	0.11
L7	1.20
L15	5.23
L23	11.8
L31	20.6
L39	34.6
L47	53.3
L55	75.8
L63	100

Product Specification

FIG. 2 Luminance

<Measuring point for Average Luminance & measuring point for Luminance variation>

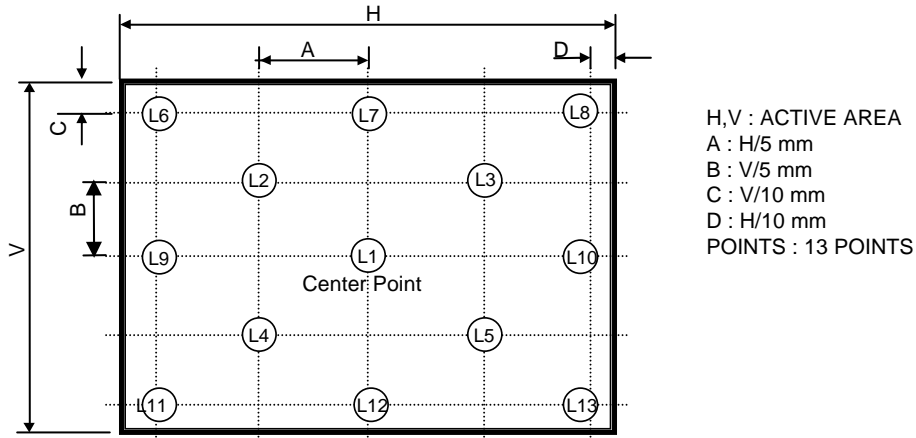

FIG. 3 Response Time

The response time is defined as the following figure and shall be measured by switching the input signal for “black” and “white”.

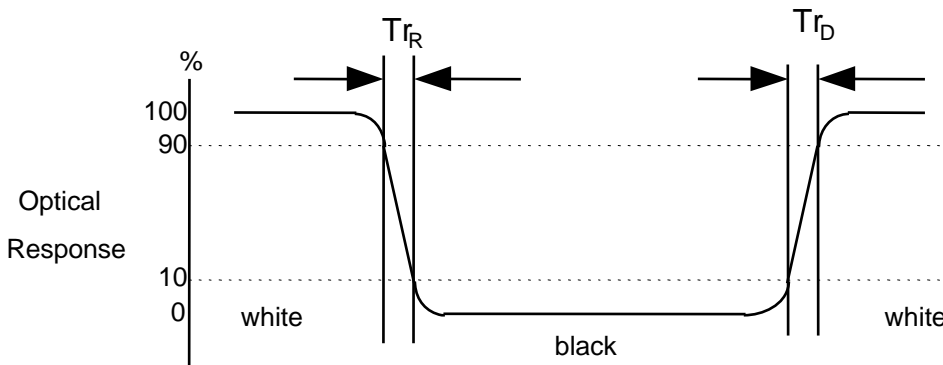
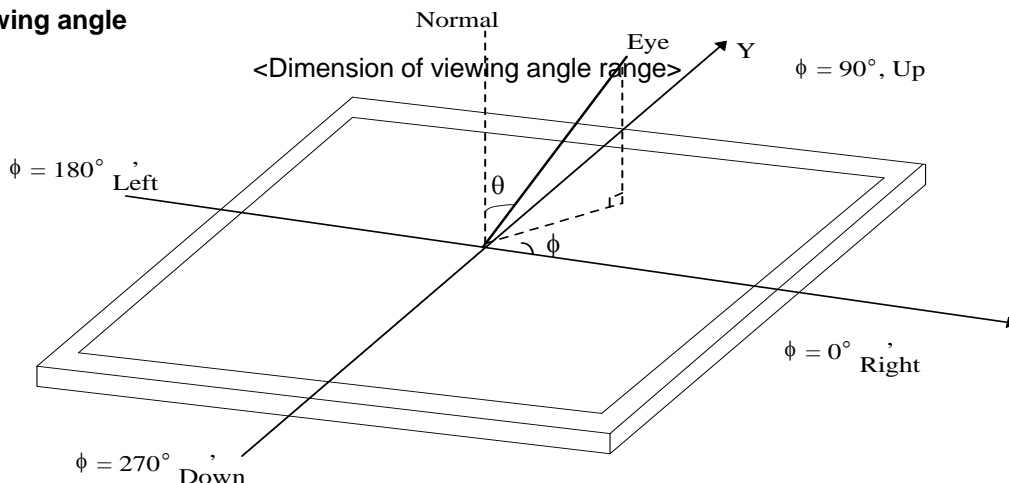

FIG. 4 Viewing angle



Product Specification

5. Mechanical Characteristics

The contents provide general mechanical characteristics for the model LP173WF1.
 In addition the figures in the next page are detailed mechanical drawing of the LCD.

Outline Dimension	Horizontal	398.1 ± 0.50mm
	Vertical	232.8 ± 0.50mm
	Depth	6.0mm(Max.)
Bezel Area	Horizontal	1.5mm Min.(Larger than Active Display Area)
	Vertical	1.5mm Min.(Larger than Active Display Area)
Active Display Area	Horizontal	381.888mm
	Vertical	214.812 mm
Weight	580g (Max.)	
Surface Treatment	3H Glare treatment of the front Polarizer (Haze 0%)	
Mother Glass Thickness	Upper Glass (C/F Glass)	0.50 + 0.05 / -0.03 mm
	Lower Glass (TFT Glass)	0.50 + 0.05 / -0.03 mm

Product Specification

<REAR VIEW>

Note) Unit:[mm], General tolerance: ± 0.5mm

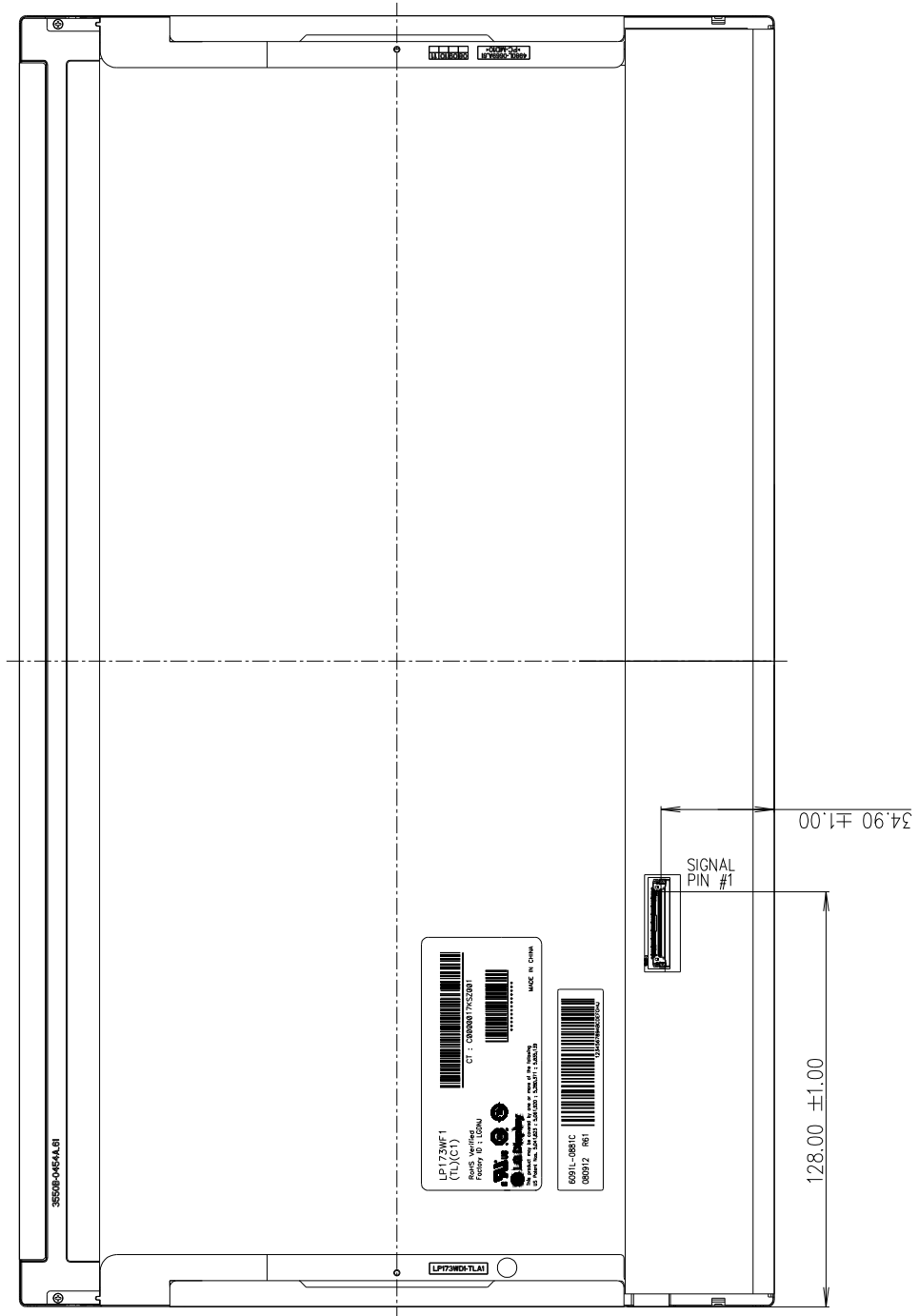

Product Specification

6. Reliability

Environment test condition

No.	Test Item	Conditions
1	High temperature storage test	Ta= 60°C, 240h
2	Low temperature storage test	Ta= -20°C, 240h
3	High temperature operation test	Ta= 50°C, 50%RH, 240h
4	Low temperature operation test	Ta= 0°C, 240h
5	Vibration test (non-operating)	Sine wave, 5 ~ 150Hz, 1.5G, 0.37oct/min 3 axis, 30min/axis
6	Shock test (non-operating)	Half sine wave, 180G, 2ms one shock of each six faces(i.e. run 180G 2ms for all six faces)
7	Altitude operating storage / shipment	0 ~ 10,000 feet (3,048m) 24Hr 0 ~ 40,000 feet (12,192m) 24Hr
8	Image Sticking ¹⁾	Ta= 25°C, Pattern : Mosaic(8 by 6), Operating Time : 30 min Lamp Operating Current : 6.0mA

{ Result Evaluation Criteria }

There should be no change which might affect the practical display function when the display quality test is conducted under normal operating condition.

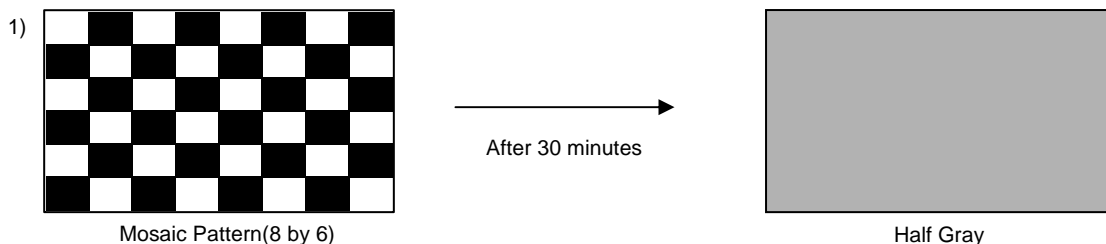

<Judgment Condition>

: Operating during 30 minutes with Mosaic Pattern(8 by 6), there is no Image Sticking after 10 second with half gray pattern.

7. International Standards

7-1. Safety

- a) UL 60950-1, Second Edition, Underwriters Laboratories Inc.
Information Technology Equipment - Safety - Part 1 : General Requirements.
- b) CAN/CSA C22.2 No.60950-1-07, Second Edition, Canadian Standards Association.
Information Technology Equipment - Safety - Part 1 : General Requirements.

- d) IEC 60950-1:2005, Second Edition, The International Electrotechnical Commission (IEC).
Information Technology Equipment - Safety - Part 1 : General Requirements.

7-2. EMC

- a) ANSI C63.4 "American National Standard for Methods of Measurement of Radio-Noise Emissions from Low-Voltage Electrical and Electronic Equipment in the Range of 9 kHz to 40 GHz." American National Standards Institute (ANSI), 2003.
- b) CISPR 22 "Information technology equipment – Radio disturbance characteristics – Limit and methods of measurement." International Special Committee on Radio Interference (CISPR), 2005.
- c) CISPR 13 "Sound and television broadcast receivers and associated equipment – Radio disturbance characteristics – Limits and method of measurement." International Special Committee on Radio Interference (CISPR), 2006.

7-3. Environment

- a) RoHS, Directive 2002/95/EC of the European Parliament and of the council of 27 January 2003

Product Specification

8. Packing

8-1. Designation of Lot Mark

a) Lot Mark

A	B	C	D	E	F	G	H	I	J	K	L	M
---	---	---	---	---	---	---	---	---	---	---	---	---

A,B,C : SIZE(INCH)
E : MONTH

D : YEAR
F ~ M : SERIAL NO.

Note

1. YEAR

Year	2001	2002	2003	2004	2005	2006	2007	2008	2009	2010
Mark	1	2	3	4	5	6	7	8	9	0

2. MONTH

Month	Jan	Feb	Mar	Apr	May	Jun	Jul	Aug	Sep	Oct	Nov	Dec
Mark	1	2	3	4	5	6	7	8	9	A	B	C

b) Location of Lot Mark

Serial No. is printed on the label. The label is attached to the backside of the LCD module.
This is subject to change without prior notice.

8-2. Packing Form

a) Package quantity in one box : 20pcs

b) Box Size :490X390X298

9. PRECAUTIONS

Please pay attention to the followings when you use this TFT LCD module.

9-1. MOUNTING PRECAUTIONS

- (1) You must mount a module using holes arranged in four corners or four sides.
- (2) You should consider the mounting structure so that uneven force (ex. Twisted stress) is not applied to the module. And the case on which a module is mounted should have sufficient strength so that external force is not transmitted directly to the module.
- (3) Please attach the surface transparent protective plate to the surface in order to protect the polarizer. Transparent protective plate should have sufficient strength in order to resist external force.
- (4) You should adopt radiation structure to satisfy the temperature specification.
- (5) Acetic acid type and chlorine type materials for the cover case are not desirable because the former generates corrosive gas of attacking the polarizer at high temperature and the latter causes circuit break by electro-chemical reaction.
- (6) Do not touch, push or rub the exposed polarizers with glass, tweezers or anything harder than HB pencil lead. And please do not rub with dust clothes with chemical treatment. Do not touch the surface of polarizer for bare hand or greasy cloth.(Some cosmetics are detrimental to the polarizer.)
- (7) When the surface becomes dusty, please wipe gently with absorbent cotton or other soft materials like chamois soaks with petroleum benzene. Normal-hexane is recommended for cleaning the adhesives used to attach front / rear polarizers. Do not use acetone, toluene and alcohol because they cause chemical damage to the polarizer.
- (8) Wipe off saliva or water drops as soon as possible. Their long time contact with polarizer causes deformations and color fading.
- (9) Do not open the case because inside circuits do not have sufficient strength.

9-2. OPERATING PRECAUTIONS

- (1) The spike noise causes the mis-operation of circuits. It should be lower than following voltage :
 $V = \pm 200\text{mV}$ (Over and under shoot voltage)
- (2) Response time depends on the temperature.(In lower temperature, it becomes longer.)
- (3) Brightness depends on the temperature. (In lower temperature, it becomes lower.)
And in lower temperature, response time(required time that brightness is stable after turned on) becomes longer.
- (4) Be careful for condensation at sudden temperature change. Condensation makes damage to polarizer or electrical contacted parts. And after fading condensation, smear or spot will occur.
- (5) When fixed patterns are displayed for a long time, remnant image is likely to occur.
- (6) Module has high frequency circuits. Sufficient suppression to the electromagnetic interference shall be done by system manufacturers. Grounding and shielding methods may be important to minimized the interference.

9-3. ELECTROSTATIC DISCHARGE CONTROL

Since a module is composed of electronic circuits, it is not strong to electrostatic discharge. Make certain that treatment persons are connected to ground through wrist band etc. And don't touch interface pin directly.

9-4. PRECAUTIONS FOR STRONG LIGHT EXPOSURE

Strong light exposure causes degradation of polarizer and color filter.

9-5. STORAGE

When storing modules as spares for a long time, the following precautions are necessary.

- (1) Store them in a dark place. Do not expose the module to sunlight or fluorescent light. Keep the temperature between 5°C and 35°C at normal humidity.
- (2) The polarizer surface should not come in contact with any other object.
It is recommended that they be stored in the container in which they were shipped.

9-6. HANDLING PRECAUTIONS FOR PROTECTION FILM

- (1) When the protection film is peeled off, static electricity is generated between the film and polarizer.
This should be peeled off slowly and carefully by people who are electrically grounded and with well ion-blown equipment or in such a condition, etc.
- (2) The protection film is attached to the polarizer with a small amount of glue. If some stress is applied to rub the protection film against the polarizer during the time you peel off the film, the glue is apt to remain on the polarizer.
Please carefully peel off the protection film without rubbing it against the polarizer.
- (3) When the module with protection film attached is stored for a long time, sometimes there remains a very small amount of glue still on the polarizer after the protection film is peeled off.
- (4) You can remove the glue easily. When the glue remains on the polarizer surface or its vestige is recognized, please wipe them off with absorbent cotton waste or other soft material like chamois soaked with normal-hexane.