

mass integrated

global part distribution • product lifecycle partner
excess inventory management • value-ad service provider



Data sheet provided by Mass Integrated

massintegrated.com • displayalliance.com

Please call +1.978.465.6190
Email: sales@massintegrated.com



ISO 9001: 2008

Mass Integrated complies with all DMCA takedown notices. Please send a formal DMCA Takedown Notice to Mass Integrated Systems, Inc. • 18 Henry Graf Jr. Road, Unit 1 • Newburyport, MA 01950.

No.	LCP-2110047-2
DATE	Dec. 03. 2010

TECHNICAL LITERATURE
FOR
TFT - LCD module

MODEL No. LS043T1LE01 (A)

TENTATIVE

The technical literature is subject to change without notice.
So, please contact Sharp or its representative before
designing your product based on this literature.

LIQUID CRYSTAL DISPLAY GROUP
SHARP CORPORATION

NOTICE

- These specification sheets are the proprietary product of SHARP CORPORATION (SHARP) and include materials protected under copyright of SHARP. Do not reproduce or cause any third party to reproduce them in any form or by any means, electronic or mechanical, for any purpose, in whole or in part, without the express written permission of SHARP.
- The application examples in these specification sheets are provided to explain the representative applications of the device and are not intended to guarantee any industrial property right or other rights or license you to use them. SHARP assumes no responsibility for any problems related to any industrial property right of a third party resulting from the use of the device.
- The device listed in these specification sheets was designed and manufactured for use in Telecommunication equipment (terminals)
- In case of using the device for applications such as control and safety equipment for transportation (aircraft, trains, automobiles, etc.), rescue and security equipment and various safety related equipment which require higher reliability and safety, take into consideration that appropriate measures such as fail-safe functions and redundant system design should be taken.
- Do not use the device for equipment that requires an extreme level of reliability, such as aerospace applications, telecommunication equipment (trunk lines), nuclear power control equipment and medical or other equipment for life support.
- SHARP assumes no responsibility for any damage resulting from the use of the device which does not comply with the instructions and the precautions specified in these specification sheets.
- Contact and consult with a SHARP sales representative for any questions about this device.

[For handling and system design]

- (1) Do not scratch the surface of the polarizer film as it is easily damaged.
- (2) If the cleaning of the surface of the LCD panel is necessary, wipe it swiftly with cotton or other soft cloth. Do not use organic solvent as it damages polarizer.
- (3) Water droplets on polarizer must be wiped off immediately as they may cause color changes, or other defects if remained for a long time.
- (4) Since this LCD panel is made of glass, dropping the module or banging it against hard objects may cause cracks or fragmentation.
- (5) Epoxy resin (amine series curing agent), silicone adhesive material (dealcoholization series and oxime series), tray forming agent (azo compound) etc, in the cabinet or the packing materials may induce abnormal display with polarizer film deterioration regardless of contact or noncontact to polarizer film. Check carefully that gas from materials used in system housing or packaging do not hurt polarizer. Be sure to confirm the component of them.
- (6) Liquid crystal material will freeze below specified storage temperature range and it will not get back to normal quality even after temperature comes back within specified temperature range. Liquid crystal material will become isotropic above specified temperature range and may not get back to normal quality. Keep the LCD module always within specified temperature range.

- (7) Do not expose LCD module to the direct sunlight or to strong ultraviolet light for long time.
- (8) If the LCD driver IC (COG) is exposed to light, normal operation may be impeded. It is necessary to design so that the light is shut off when the LCD module is mounted.
- (9) Do not disassemble the LCD module as it may cause permanent damage.
- (10) As this LCD module contains components sensitive to electrostatic discharge, be sure to follow the instructions in below.
- ① Operators
Operators must wear anti-static wears to prevent electrostatic charge up to and discharge from human body.
 - ② Equipment and containers
Process equipment such as conveyer, soldering iron, working bench and containers may possibly generate electrostatic charge up and discharge. Equipment must be grounded through 100Mohms resistance. Use ion blower.
 - ③ Floor
Floor is an important part to leak static electricity which is generated from human body or equipment. There is a possibility that the static electricity is charged to them without leakage in case of insulating floor, so the countermeasure(electrostatic earth: $1 \times 10^8 \Omega$) should be made.
 - ④ Humidity
Proper humidity of working room may reduce the risk of electrostatic charge up and discharge. Humidity should be kept over 50% all the time.
 - ⑤ Transportation/storage
Storage materials must be anti-static to prevent causing electrostatic discharge.
 - ⑥ Others
Protective film is attached on the surface of LCD panel to prevent scratches or other damages. When removing this protective film, remove it slowly under proper anti-ESD control such as ion blower.
- (11) Hold LCD very carefully when placing LCD module into the system housing. Do not apply excessive stress or pressure to LCD module. Do not to use chloroprene rubber as it may affect on the reliability of the electrical interconnection.
- (12) Do not hold or touch LCD panel to flex interconnection area as it may be damaged.
- (13) As the binding material between LCD panel and flex connector mentioned in 12) contains an organic material, any type of organic solvents are not allowed to be used. Direct contact by fingers is also prohibited.
- (14) When carrying the LCD module, place it on the tray to protect from mechanical damage. It is recommended to use the conductive trays to protect the CMOS components from electrostatic discharge. When holding the module, hold the Plastic Frame of LCD module so that the panel, COG and other electric parts are not damaged.

- (15) Do not touch the COG's patterning area. Otherwise the circuit may be damaged.
- (16) Do not touch LSI chips as it may cause a trouble in the inner lead connection.
- (17) Place a protective cover on the LCD module to protect the glass panel from mechanical damages.
- (18) LCD panel is susceptible to mechanical stress and even the slightest stress will cause a color change in background and pooling. So make sure the LCD panel is placed on flat plane without any continuous twisting, bending or pushing stress.
- (19) Protective film is placed onto the surface of LCD panel when it is shipped from factory. Make sure to peel it off before assembling the LCD module into the system. Be very careful not to damage LCD module by electrostatic discharge when peeling off this protective film. Ion blower and ground strap are recommended.
- (20) Make sure the mechanical design of the system in which the LCD module will be assembled matches specified viewing angle of this LCD module.
- (21) This LCD module does not contain nor use any ODS (1,1,1-Trichloroethane, CCL4), CFCS, Carbon tetrachloride, Halon in all materials used, in all production processes.

[For operating LCD module]

- (1) Do not operate or store the LCD module under outside of specified environmental conditions.
- (2) At the shipment, adjust the contrast of each LCD module with electric volume. LCD contrast may vary from panel to panel depending on variation of LCD power voltage from system.
- (3) As opt-electrical characteristics of LCD will be changed, dependent on the temperature, the confirmation of display quality and characteristics has to be done after temperature is set at 25 °C and it becomes stable.

[Precautions for Storage]

- (1) Do not expose the LCD module to direct sunlight or strong ultraviolet light for long periods. Store in a dark place.
- (2) The liquid crystal material will solidify if stored below the rated storage temperature and will become an isotropic liquid if stored above the rated storage temperature, and may not retain its original properties. Only store the module at normal temperature and humidity (25±5°C,60±10%RH) in order to avoid exposing the front polarizer to chronic humidity.
- (3) Keeping Method

a. Don't keeping under the direct sunlight.

b. Keeping in the tray under the dark place.

DON'T

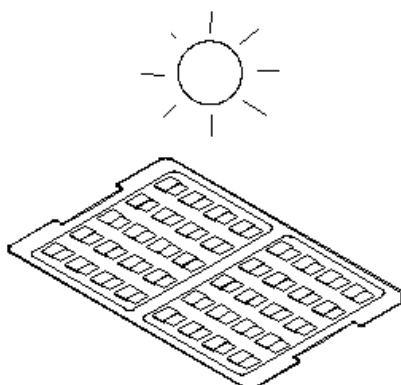

DO

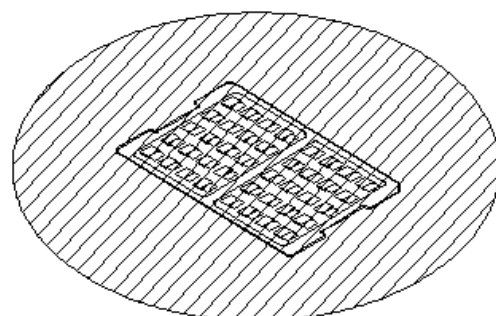

- (1) Do not operate or store the LCD module under outside of specified environmental conditions.
- (2) Be sure to prevent light striking the chip surface.

[Other Notice]

- (1) Do not operate or store the LCD module under outside of specified environmental conditions.
- (2) As electrical impedance of power supply lines (VCI/VDDIO-GND) are low when LCD module is working, place the de-coupling capacitor near by LCD module as close as possible.
- (3) Reset signal must be sent after power on to initialize LSI. LSI does not function properly until initialize it by reset signal.
- (4) Generally, at power on, in order not to apply DC charge directly to LCD panel, supply logic voltage first and initialize LSI logic function including polarity alternation. Then supply voltage for LCD bias. At power off, in order not to apply DC charge directly to LCD panel, execute Power OFF sequence and Discharge command.
- (5) Don't touch to FPC surface, exposed IC chip, electric parts and other parts, to any electric, metallic materials.
- (6) No bromide specific fire-retardant material is used in this module.
- (7) Do not display still picture on the display over 2 hours as this will damage the liquid crystal.
- (8) This product doesn't support active backlight function. Use active back light function with this product at your discretion and responsibility.

[Precautions for Discarding Liquid Crystal Modules]

COG: After removing the LSI from the liquid crystal panel, dispose of it in a similar way to circuit boards from electronic devices.

LCD panel: Dispose of as glass waste. This LCD module contains no harmful substances. The liquid crystal panel contains no dangerous or harmful substances. The liquid crystal panel only contains an extremely small amount of liquid crystal (approx.100mg) and therefore it will not leak even if the panel should break.

-Its median lethal dose (LD50) is greater than 2,000 mg/kg and a mutagenetic (Aims test: negative) material is employed.

FPC: Dispose of as similar way to circuit board from electric device.

1. Application

This data sheet is to introduce the specification of LS043T1LE01 active matrix 16.7Mcolors LCD module. LCD module is controlled by Driver IC (Novatek/N35565).

If any problem occurs concerning the items not stated in this specification, it must be solved sincerely by both parties after deliberation.

2. Construction and Outline

This module is a color transmissive, high contrast, wide viewing angle and active matrix LCD module incorporating amorphous silicon TFT (Thin Film Transistor), named ASV LCD (Advanced Super View LCD). 3D display parallax barer is integrated.

Construction: LCD panel, Driver (COG), FPC with electric components, 10 white LEDs prism sheet, diffuser, light guide and reflector, plastic frame and metal frame to fix them mechanically. Parallax barer panel with FPC is laminated.

Outline: See page 24 (Outline Dimensions)

Connection Main LCD : ZIF connector (AYF332335 (PANASONIC))

Connection 3D switching LCD : ZIF connector (04 6277 604 001 883+ (Kyocera))

There shall be no scratches, stains, chips, distortions and other external drawbacks that may affect the display function.

Rejection criteria shall be noted in Inspection Standard.

3. Mechanical (Physical) Specifications

Table1

Item	Specifications	Unit	Remarks
Screen size	10.9 (4.29" type) Diagonal	cm	
Active area	53.46(H)×95.04(V)	mm	
Pixel format	540(H)×960(V)	pixel	2D display mode
	1 Pixel =R+G+B dots	-	
Pixel pitch	0.099(H)×0.099(V)	mm	
Pixel configuration	R,G,B vertical stripes	-	
Display mode	Normally black	-	
Number of colors	16,777,216	colors	24bits
Unit outline dimensions	58.54(W)×105.7(H)×2.48(D) (TYP.)	mm	【Note3-1】
Mass	TBD	g	

【Note3-1】 The above-mentioned table indicates module sizes without some projections and FPC.

For detailed measurements and tolerances, please refer to Outline Dimensions.

4. Pixel Configuration

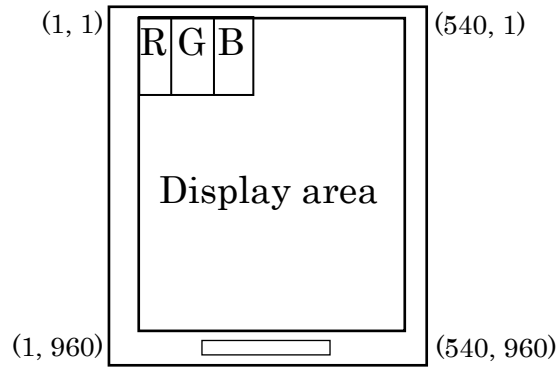

5. Input Terminal Names and Functions – Main LCD

Table2

Pin No.	Symbol	I/O	Description	Remarks
1	LED+	-	High Voltage Power Supply for LED	
2	LED-	-	Low Voltage Power Supply for LED	
3	GND	-	Ground	
4	TE	O	Tearing Effect	
5	IOVDD	-	Power Supply of Digital	
6	AVDD	-	Input to DC/DC	
7	LEDPWM	O	Back Light LED control signal	
8	XRES	I	Reset	"L"Active
9	GND	-	Ground	
10	VR	-	Test pin	Open
11	CTS1/ID1/IM1	I/O	Control signal 1/ID1, Pull down 100kohm to GND MDDI & MIPI interface selected pin	ID1="L" L:MIPI H:MDDI
12	GND	-	Ground	
13	GND	-	Ground	
14	MDDI_STBM/DSI_CLKN	I	MDDI Strobe- / MIPI DSI clock-	
15	MDDI_STBP/DSI_CLKP	I	MDDI Strobe+ / MIPI DSI clock+	
16	GND	-	Ground	
17	MDDI_DM1/DSI_D0N	I/O	MDDI data1- / MIPI DSI data0-	
18	MDDI_DP1/DSI_D0P	I/O	MDDI data1+ / MIPI DSI data0+	
19	GND	-	Ground	
20	MDDI_DM2/DSI_D1N	I/O	MDDI data2- / MIPI DSI data1-	
21	MDDI_DP2/DSI_D1P	I/O	MDDI data2+ / MIPI DSI data1+	
22	GND	-	Ground	
23	GND/MTP_PWR	-	Voltage supply pin for MTP, Please Connect to Ground	GND

Fitting connector : ZIF connector (PANASONIC AYF332335)







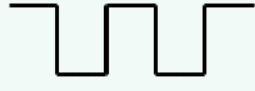
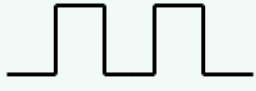

Input Terminal Names and Functions – Switching LCD

Table3

Pin No.	Symbol	I/O	Description	Remarks
1	GPIO1	I	Switching LCD driving signal 1	
2	GPIO2	I	Switching LCD driving signal 2	
3	GPIO3	I	Switching LCD driving signal 3	
4	GPIO4	I	Switching LCD driving signal 4	

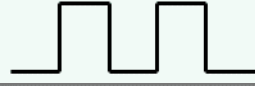
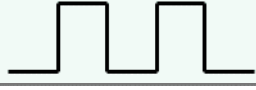
Fitting connector: ZIF connector (KYOCERA 04 6277 604 001 883+)

Driving Signals of Switching Panel

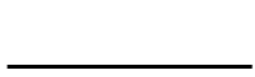
	3D Landscape	3D Portrait	2D
GPIO1			
GPIO2			
GPIO3			
GPIO4			

6. Absolute Maximum Ratings

Table 4

GND=0V

Parameter	Symbol	Conditions	Rated value	Unit	Remarks
Driver IC (Analog) Power Supply Voltage	AVDD	Ta=+25°C	-0.3 ~ +5.5	V	【Note6-1】
Driver IC (Digital) Power Supply Voltage	IOVDD	Ta=+25°C	-0.3 ~ +5.5	V	【Note6-1】
Temperature for storage	T _{stg}	-	-30 ~ +70	°C	【Note6-2】
Temperature for operation	T _{opr}	-	-20 ~ +60	°C	【Note6-2】
LED Input electric current	I _{LED}	Ta=+25°C	35	mA	【Note6-3】

【Note6-1】 Voltage applied to GND pins. GND pin conditions are based on all the same voltage (0V).

Always connect all GND externally and use at the same voltage.

【Note6-2】 Humidity : 95%RHMax.(at Ta≤40°C). Maximum wet-bulb temperature is less than 39°C(at Ta>40°C). Condensation of dew must be avoided.

【Note6-3】 Ambient temperature and the maximum input are fulfilling the following operating conditions.

■ Ambient Temperature vs.
Allowable Forward Current

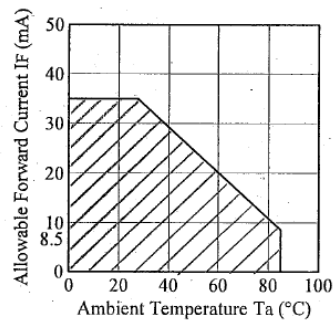

7. Electrical Characteristics

7-1. MAIN LCD Panel Driving Section

Table 5

GND=0V

Parameter	Symbol	Min.	Typ.	Max.	Unit	Remarks
Driver IC(Analog) Power Supply Voltage	AVDD	2.85	3.0	3.3	V	【Note7-1】
Driver IC(Digital) Power Supply Voltage	IOVDD	1.65	1.8	AVDD	V	【Note7-1】
Input voltage (Low)	V_{IL}	0	-	0.3VDDIO	V	【Note7-2】
Input voltage (High)	V_{IH}	0.7VDDIO	-	VDDIO	V	【Note7-2】
Input current (Low)	I_{IL}	-1	-	-	μ A	
Input current (High)	I_{IH}	-	-	1	μ A	
Output voltage (Low)	V_{oL}	0	-	0.2VDDIO	V	TE / LEDPWM $I_{oL}=+0.1mA$
Output voltage (High)	V_{oH}	0.8VDDIO	-	VDDIO	V	TE / LEDPWM $I_{oH}=-0.1mA$
Power consumption	IAVDD	-	43.43	TBD	mA	【Note7-3】
	IVDDIO	-	0.004	TBD		

【Note7-1】 Include Ripple Noise

【Note7-2】 Applied overshoot / XRES signal

【Note7-3】 Measurement Conditions : **White pattern, AVDD=3.0V, Static image**

※Please refer to specification of "Novatek NT35565" for detail.

Table 6 - MDDI mode

Parameter	Symbol	Min.	Typ.	Max.	Unit	Remarks
Differential input high level voltage (VT=125mV) (MDDI_DATA_P/N)	VIT+off	-	125	175	mV	
Differential input low level voltage (VT=125mV) (MDDI_DATA_P/N)	VIT-off	75	125	-	mV	
Differential input high level voltage (VT=0) (MDDI_DATA_P/N)	VIT+	-	0	50	mV	
Differential input low level voltage (VT=0) (MDDI_DATA_P/N)	VIT-	-50	0	-	mV	
Termination impedance for MDDI interface	Zt	80	100	125	ohm	

Table 7 – MIPI DSI mode

Parameter	Symbol	Min.	Typ.	Max.	Unit	Remarks
High speed mode						
Single ended input low voltage	VILHS	-40	-	-	mV	
Single ended input high voltage	VIHHS	-	-	460	mV	
Common mode voltage	VCMRXDC	70		330	mV	
Differential impedance	ZID	80	100	125	ohm	
High speed transmit differential voltage	VOD	140	200	250	mV	
Low power mode						
Pad signal voltage range	VI	-50	-	1350	mV	
Ground Shift	VGNDSH	-50	-	50	mV	
Logic 0 input threshold	VIL	0	-	550	mV	
Logic 1 input threshold	VLH	880	-	1350	mV	
Input hysteresis	VHYST	25	-	-	mV	
Output low level	VOL	-50	-	50	mV	
Output high level	VOH	1.1	1.2	1.3	V	
Output impedance of Low Power transmitter	ZOLP	80	100	125	Ohm	
Logic 0 contention threshold	VIHCDCMAX	0.0	-	200	mV	
Logic 1 contention threshold	VIHCDCMIN	450	-	1350	mV	

7-2. Back Light Driving Section

Table 8

Ta=+25°C, GND=0V

Parameter	Symbol	Min.	Typ.	Max.	Unit	Remarks
LED Voltage	V _{LED}	-	30	-	V	【Note7-4】
LED Current	I _{LED}	-	20	-	mA	
Power Consumption	W _{LED}	-	600	-	mW	【Note7-5】
LED Quantity			10		pcs	

【Note7-4】 at I_{LED}=20mA【Note7-5】 W_{LED}=V_L×I_L

7-3. Switching panel driving section

Table 9

Parameter	Symbol	Min.	Typ.	Max.	Unit	Remarks
GPIO high voltage (root mean square)	VRMS	5.1	5.3	5.5	V	

8. Timing characteristics of input signals

Please refer to specification of “Novatek / N35565” for detail.

8-1.MDDI Interface

Table 10 Ta=25 degree Ta=+25°C, GND=0V, AVDD=2.85V to 3.3V, IOVDD=1.65V to 3.3V

Symbol	Parameter	Min	Typ	Max	Unit
1/tBIT	Data transfer rate	-	384	(400)	Mbps (Par lane)
Tskew-pair	Differential transfer input skew	-	-	0.25	ns
Tskew-data	Data Stb input skew	-	-	0.3	ns

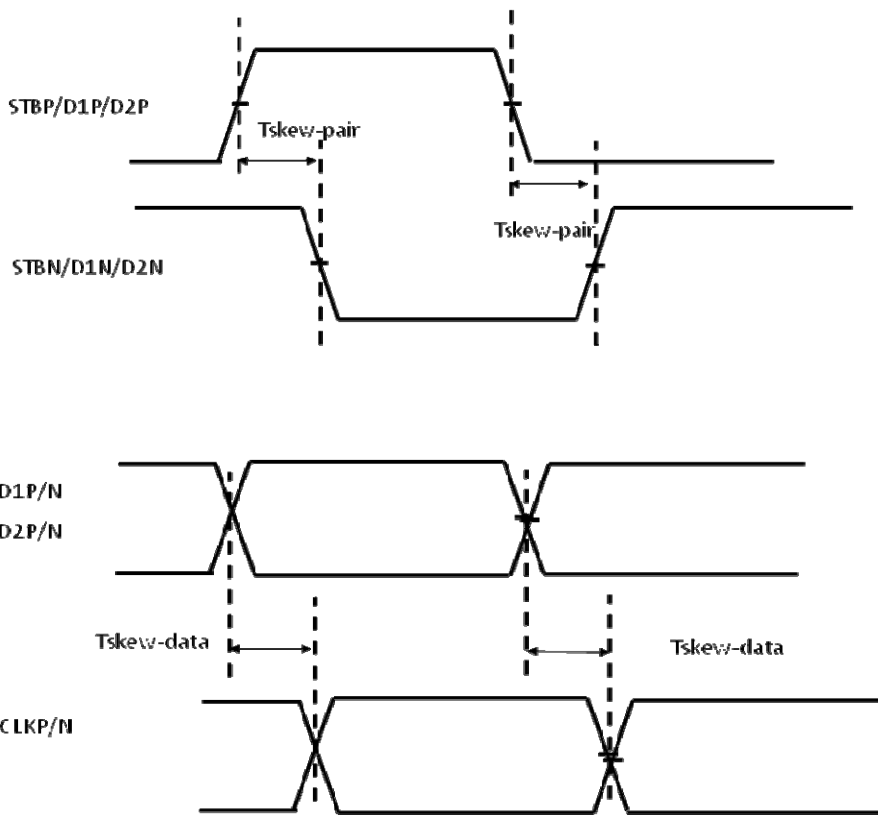

8-2. MIPI DSI interface

Table 11

Ta=+25°C, GND=0V, AVDD=2.85V to 3.3V, IOVDD=1.65V to 3.3V

Parameter	Symbol	Min	Typ	Max	Unit	Note
Transmission rate	$1/ UI_{INST}$	80	-	(510)	Mbps/lane	
UI instantaneous	UI_{INST}	(1.96)	-	12.5	ns	1,2
Data to Clock Skew [measured at transmitter]	$T_{SKEW}[TX]$	(-0.15)	-	(0.15)	UI_{INST}	3
Data to Clock Setup Time [measured at receiver]	$T_{SETUP}[RX]$	(0.15)			UI_{INST}	4
Data to Clock Hold Time [measured at receiver]	$T_{HOLD}[RX]$	(0.15)			UI_{INST}	4
20% - 80% rise time and fall time	Tr/Tf	(150)	-	-	ps	
		-	-	(0.3)	UI_{INST}	

Data-Clock Timing

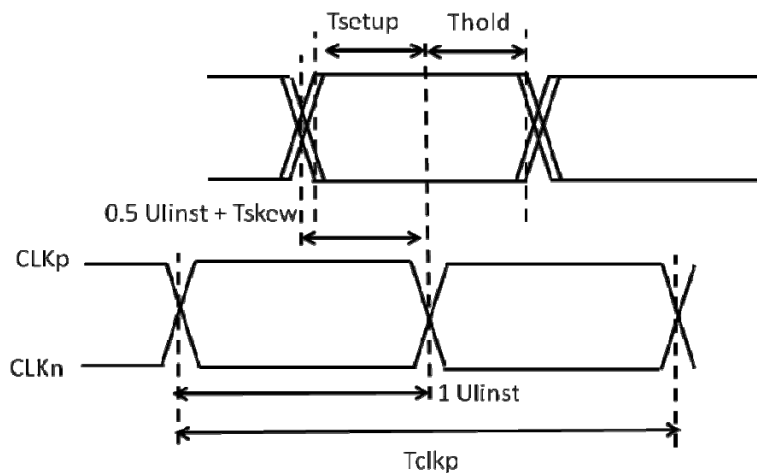

Note 1 : This value corresponds to minimum 80MHz rate.

Note 2 : The minimum UI shall not violated for any single bit period.

Note 3 : Total delay budget of $0.3 UI_{INST}$.

Note 4 : Total setup and hold window for receiver of $0.3 UI_{INST}$.

MIPI DSI Interface (D-PHY: V0.90.00 , DSI:1.01.00 R11, DCS:1.01.00)

8-3. Reset timing Characteristics

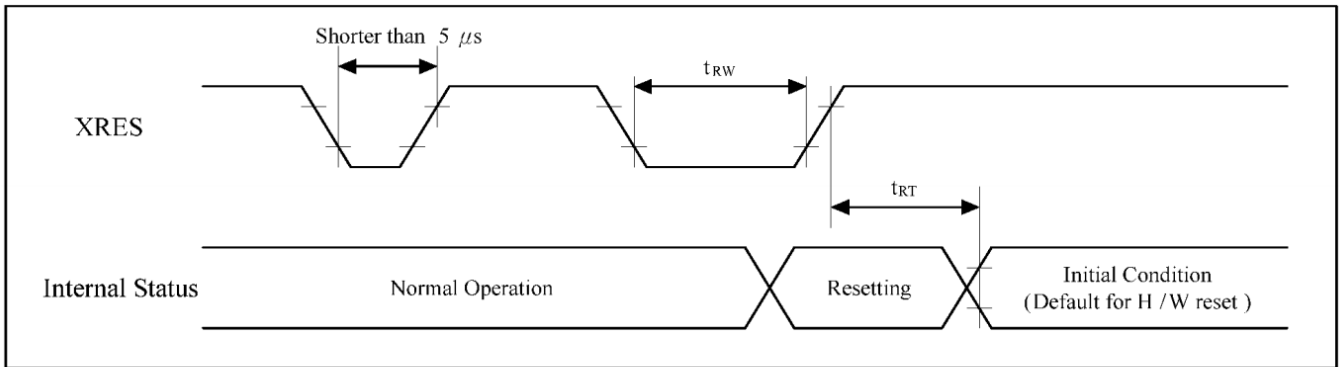

T_a=+25°C, GND=0V, AVDD=2.85V to 3.3V, IOVDD=1.65V to 3.3V

Signal	Symbol	Parameter	Min.	Max.	Unit
XRES	t _{RW}	Reset pulse duration	10(Note)	-	us
	t _{RT}	Reset cancel	-	5(Note)	ms
-			120(Note)	ms	

Note :

- The reset cancel also includes required time for loading ID bytes, VCOM setting and other settings from EEPROM (or similar device) to registers. This loading is done every time when there is HW reset cancel time (t_{RT}) within 5 ms after a rising edge of XRES.
- Spike due to an electrostatic discharge on XRES line does not cause irregular system reset according to the table below :

XRES	Pulse Action
Shorter than 5us	Reset Rejected
Longer than 9us	Reset
Between 5us and 9us	Reset Starts

- During the Resetting period, the display will be blanked(The display is entering blanking sequence, which maximum time is 120 ms, when Reset Starts in Sleep-Out mode. The display remains the blank state in Sleep-In mode). Then return to Default condition for Hardware Reset.
- Spike Rejection also applies during a valid reset pulse as shown below :

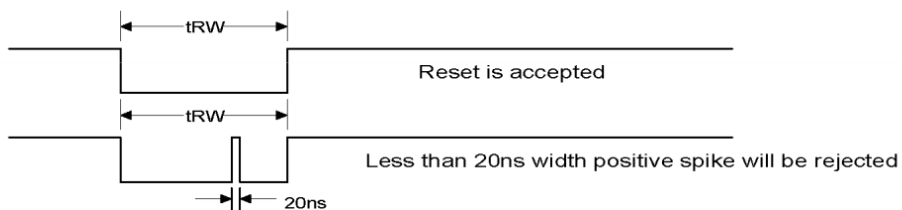

- When Reset applied during Sleep-In Mode.
- When Reset applied during Sleep-Out Mode.
- It is necessary to wait 5ms after releasing XRES before sending commands. Also Sleep Out command cannot be sent for 120 ms.

8-4. Switch LCD driving timing

Initial Condition GPIO1, 2, 3, 4 : "L"

Table 12

Parameter	Symbol	MIN.	TYP.	MAX.	Unit	Remarks
GPIO Rise time	Tr	-	-	50	us	
GPIO fall time	Tf	-	-	50	us	
GPIO frequency	f=1/T	60	-	120	Hz	
GPIO phase difference	Tph	-	-	10	us	
Duty cycle	-	49	50	51	%	

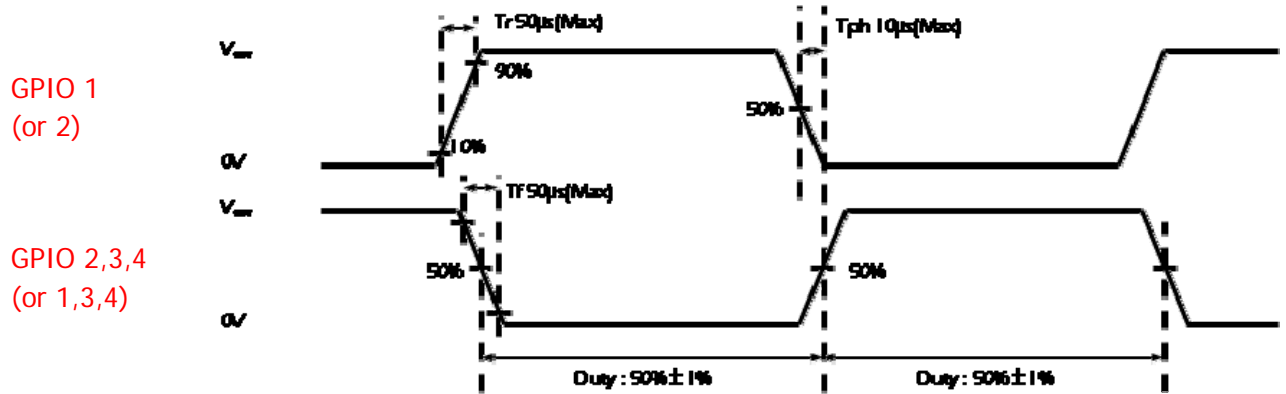

9. Power Sequence

9-1 MDDI Power On Sequence

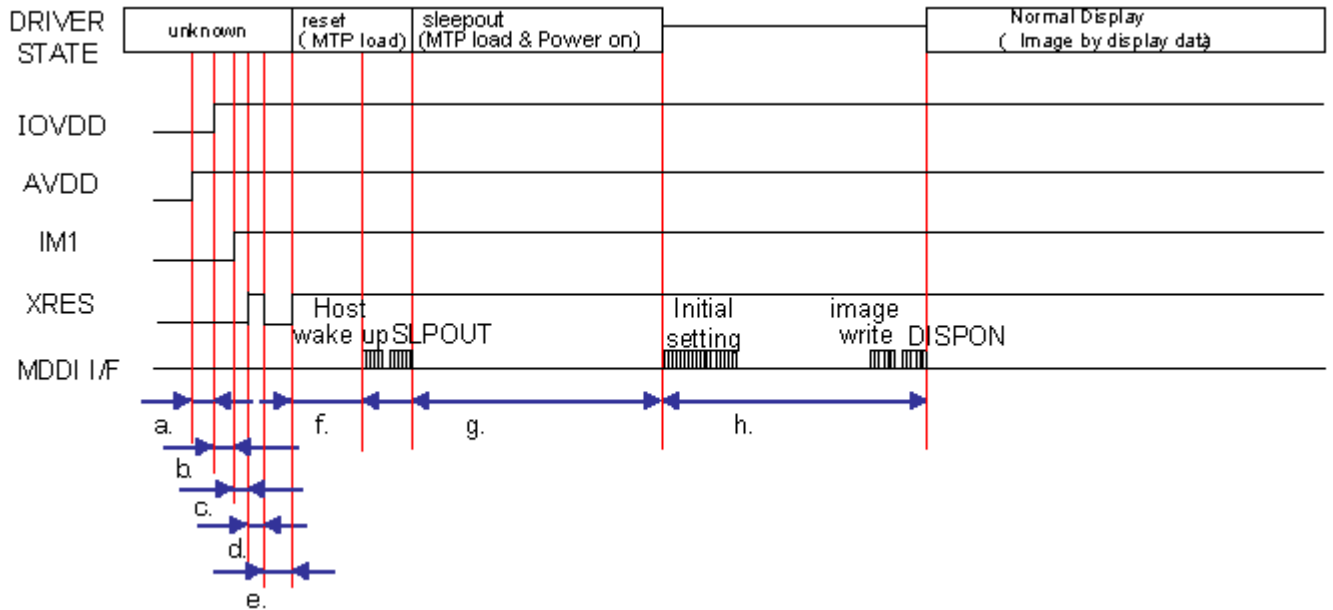

Table 13

Recommended Power On Sequence					term
Step	Reg.	Data	Delay	Command	
1	Initial condition			XRES = L , IM1 = L	
2	Power Supply AVDD			AVDD ON	
3			Min 0 ms - Max.10 ms		a.
4	Power Supply IOVDD			IOVDD ON	
5			Min. 10ms		b.
6				IM1 = H	
7			Min. 1μs		c.
8				XRES = H	
9			Min. 10 μs		d.
10				XRES = L	
11			Min. 20 μs		e.
12				XRES = H (release)	
13			Min. 20 ms		f.
14				Host Wake up	
15	0x1100	0x0000		SLEEP OUT	
16			Min. 150 ms		g.
17	0x____	0x____		Initial setting (If you need the other register setting)	h.
18	0x____	0x____		Image Write(Send Video Stream Packet)	
19	0x2900	0x0000		Display ON	
20	Power Supply GPIO1-4			3D-LCD Display ON (GPIO1-GPIO4 ON)	

9-2 MDDI Power Off Sequence

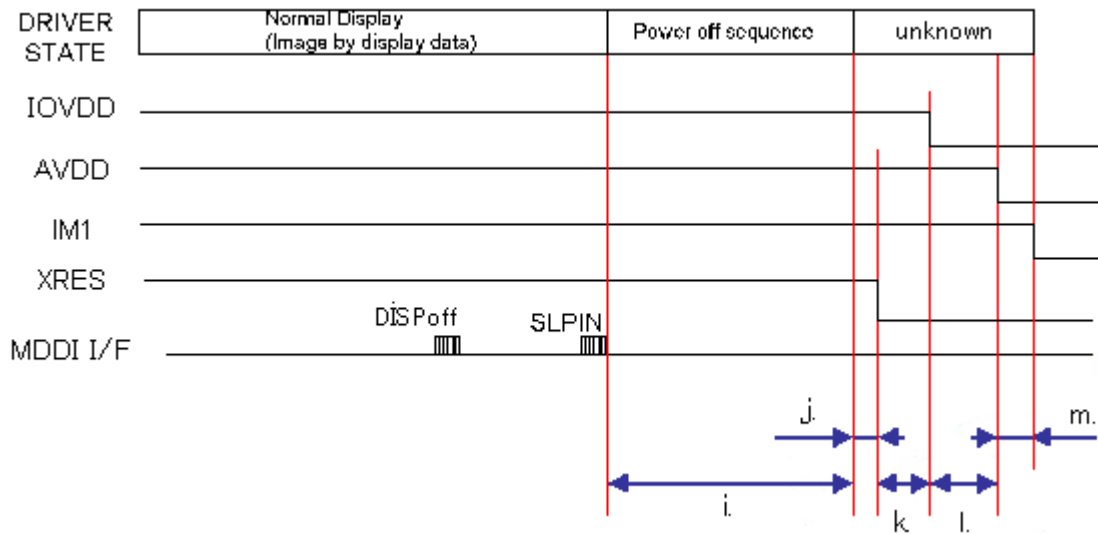

Table 14

Recommended Power Off Sequence					term
Step	Reg.	Data	Delay	Command	
1	Power OFF GPIO1-4			3D Display OFF (GPIO1-4 OFF)	
2	0x2800	0x0000		Display off	
3	0x1000	0x0000		Sleep In	
4			Min. 100ms		i.
5			Min. 0ms		j.
6				XRES = L	
7			Min. 0ms		k.
8	Power OFF			IOVDD OFF	
			Min. 0ms - Max. 10ms		l.
			Min. 0ms	AVDD OFF	
				IM1 = L	m.

9-3 MIPI Power On Sequence

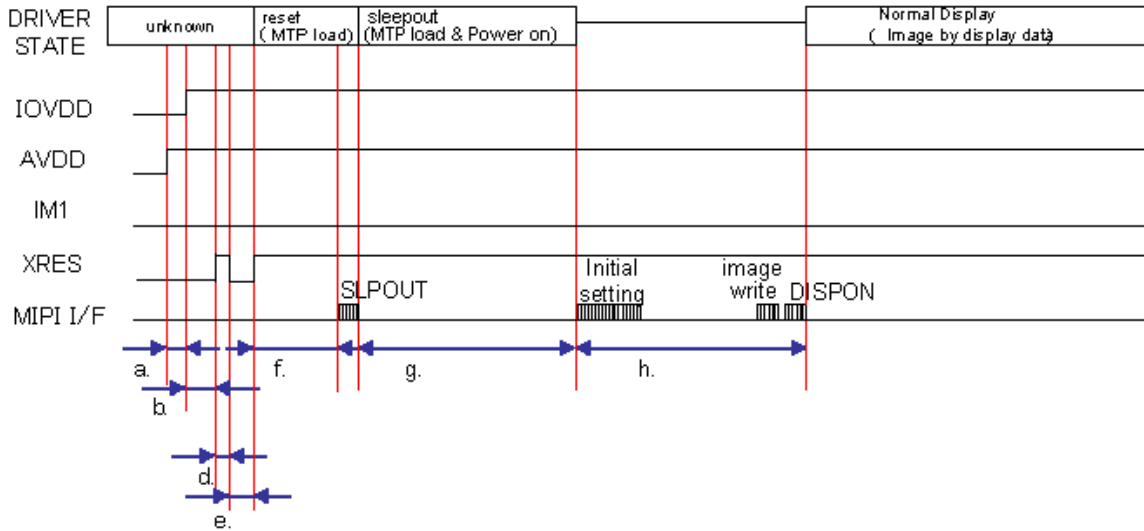

Table 15

Recommended Power On Sequence					term
Step	Reg.	Data	Delay	Command	
1	Initial condition			XRES = L , IM1 = L	
2	Power Supply AVDD			AVDD ON	
3			Min 0 ms - Max.10 ms		a.
4	Power Supply IOVDD			IOVDD ON	
5			Min. 10ms		b.
6				XRES = H	
7			Min. 10 μs		d.
8				XRES = L	
9			Min. 20 μs		e.
10				XRES = H (release)	
11			Min. 10 ms		f.
12	0x11	0x00		SLEEP OUT	
13			Min. 150 ms		g.
14	0x__	0x__		Initial setting (If you need the other register setting)	h.
15	0x__	0x__		Image Write(Send Video Stream Packet)	
16	0x29	0x00		Display ON	
17	Power Supply GPIO1-4			3D-LCD Display ON (GPIO1-GPIO4 ON)	

9-4 MIPI Power Off Sequence

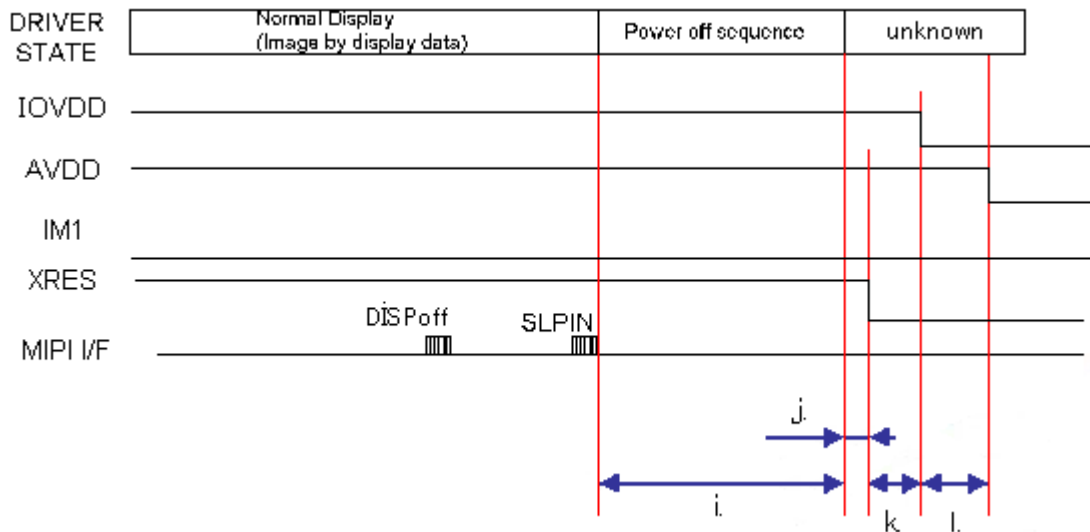

Table 16

Recommended Power Off Sequence					term
Step	Reg.	Data	Delay	Command	
1	Power OFF GPIO1-4			3D Display OFF (GPIO1-4 OFF)	
2	0x28	0x00		Display off	
3	0x10	0x00		Sleep In	
4			Min. 100ms		i.
5			Min. 0ms		j.
6				XRES = L	
7			Min. 0ms		k.
8	Power OFF			IOVDD OFF	
			Min. 0ms - Max. 10ms		l.
				AVDD OFF	

10. Input Signals, Basic Display Colors and Gray Scale of Each Color

Table 17

	Colors & Gray Scale	Data signals																											
		Gray Scale	R0	R1	R2	R3	R4	R5	R6	R7	G0	G1	G2	G3	G4	G5	G6	G7	B0	B1	B2	B3	B4	B5	B6	B7			
		LSB							MSB							LSB							MSB						
Basic Color	Black	—	0	0	0	0	0	0	0	0	0	0	0	0	0	0	0	0	0	0	0	0	0	0	0	0			
	Blue	—	0	0	0	0	0	0	0	0	0	0	0	0	0	0	0	0	1	1	1	1	1	1	1	1			
	Green	—	0	0	0	0	0	0	0	0	1	1	1	1	1	1	1	1	0	0	0	0	0	0	0	0			
	Cyan	—	0	0	0	0	0	0	0	0	1	1	1	1	1	1	1	1	1	1	1	1	1	1	1	1			
	Red	—	1	1	1	1	1	1	1	1	0	0	0	0	0	0	0	0	0	0	0	0	0	0	0	0			
	Magenta	—	1	1	1	1	1	1	1	1	0	0	0	0	0	0	0	0	1	1	1	1	1	1	1	1			
	Yellow	—	1	1	1	1	1	1	1	1	1	1	1	1	1	1	1	1	0	0	0	0	0	0	0	0			
	White	—	1	1	1	1	1	1	1	1	1	1	1	1	1	1	1	1	1	1	1	1	1	1	1	1			
Gray Scale of Red	Black	GS0	0	0	0	0	0	0	0	0	0	0	0	0	0	0	0	0	0	0	0	0	0	0	0	0			
	↑	GS1	1	0	0	0	0	0	0	0	0	0	0	0	0	0	0	0	0	0	0	0	0	0	0	0			
	Darker	GS2	0	1	0	0	0	0	0	0	0	0	0	0	0	0	0	0	0	0	0	0	0	0	0	0			
	↑	↓	↓							↓							↓												
	↓	↓	↓							↓							↓												
	Brighter	GS253	1	0	1	1	1	1	1	1	0	0	0	0	0	0	0	0	0	0	0	0	0	0	0	0			
	↓	GS254	0	1	1	1	1	1	1	1	0	0	0	0	0	0	0	0	0	0	0	0	0	0	0	0			
	Red	GS255	1	1	1	1	1	1	1	1	0	0	0	0	0	0	0	0	0	0	0	0	0	0	0	0			
Gray Scale of Green	Black	GS0	0	0	0	0	0	0	0	0	0	0	0	0	0	0	0	0	0	0	0	0	0	0	0	0			
	↑	GS1	0	0	0	0	0	0	0	0	1	0	0	0	0	0	0	0	0	0	0	0	0	0	0	0			
	Darker	GS2	0	0	0	0	0	0	0	0	0	1	0	0	0	0	0	0	0	0	0	0	0	0	0	0			
	↑	↓	↓							↓							↓												
	↓	↓	↓							↓							↓												
	Brighter	GS253	0	0	0	0	0	0	0	0	1	0	1	1	1	1	1	1	0	0	0	0	0	0	0	0			
	↓	GS254	0	0	0	0	0	0	0	0	0	1	1	1	1	1	1	1	0	0	0	0	0	0	0	0			
	Green	GS255	0	0	0	0	0	0	0	0	1	1	1	1	1	1	1	1	0	0	0	0	0	0	0	0			
Gray Scale of Blue	Black	GS0	0	0	0	0	0	0	0	0	0	0	0	0	0	0	0	0	0	0	0	0	0	0	0	0			
	↑	GS1	0	0	0	0	0	0	0	0	0	0	0	0	0	0	0	0	1	0	0	0	0	0	0	0			
	Darker	GS2	0	0	0	0	0	0	0	0	0	0	0	0	0	0	0	0	0	1	0	0	0	0	0	0			
	↑	↓	↓							↓							↓												
	↓	↓	↓							↓							↓												
	Brighter	GS253	0	0	0	0	0	0	0	0	0	0	0	0	0	0	0	0	1	0	1	1	1	1	1	1			
	↓	GS254	0	0	0	0	0	0	0	0	0	0	0	0	0	0	0	0	0	1	1	1	1	1	1	1			
	Blue	GS255	0	0	0	0	0	0	0	0	0	0	0	0	0	0	0	0	1	1	1	1	1	1	1	1			

Low level voltage, 1: High level voltage

Each basic color can be displayed in 256 gray scales from 8 bit data signals. According to the combination of total 24 bit data signals, the 16,777,216-color display can be achieved on the screen.

11. Optical Characteristics

11-1 Driving the Back Light Condition

Table 18

 $I_{LED}=20mA$, $T_a=+25^{\circ}C$

Parameter	Symbol	Condition	Min.	Typ.	Max.	Unit	Remark
Viewing Angle Range*1	θ_{21}, θ_{22}	CR>10	-	80	-	degree	【Note11-1, 11-2】
	θ_{11}, θ_{12}		-	80	-		
Contrast Ratio *1	CR	$\theta=0^{\circ}$	TBD	800	-	-	【Note11-2】
Response Time *1	$T_r + T_d$	$\theta=0^{\circ}$	-	35	-	ms	【Note11-3】
White Chromaticity*1	x	$\theta=0^{\circ}$	(0.260)	0.310	(0.360)	-	
	y		(0.270)	0.320	(0.370)	-	
Brightness 2D mode	X_{L12}	$\theta=0^{\circ}$	TBD	450	-	cd/m ²	$I_{LED}=20mA$
Brightness 3D mode	X_{L13}	$\theta=0^{\circ}$	-	200	-		
Uniformity *1	U	$\theta=0^{\circ}$	75	-	-	%	【Note11-4】
NTSC Ratio *1	S	$\theta=0^{\circ}$	TBD	70	-	%	
3D mode right eye cross talk	XTRE		-	1.5	-	%	【Note11-5】
3D mode left eye cross talk	XTLE		-	1.5	-	%	【Note11-5】

*1: 2D mode

*The measuring method of the optical characteristics is shown by the following figure.

*A measurement device is TOPCON luminance meter SR-3.(Viewing cone1.)

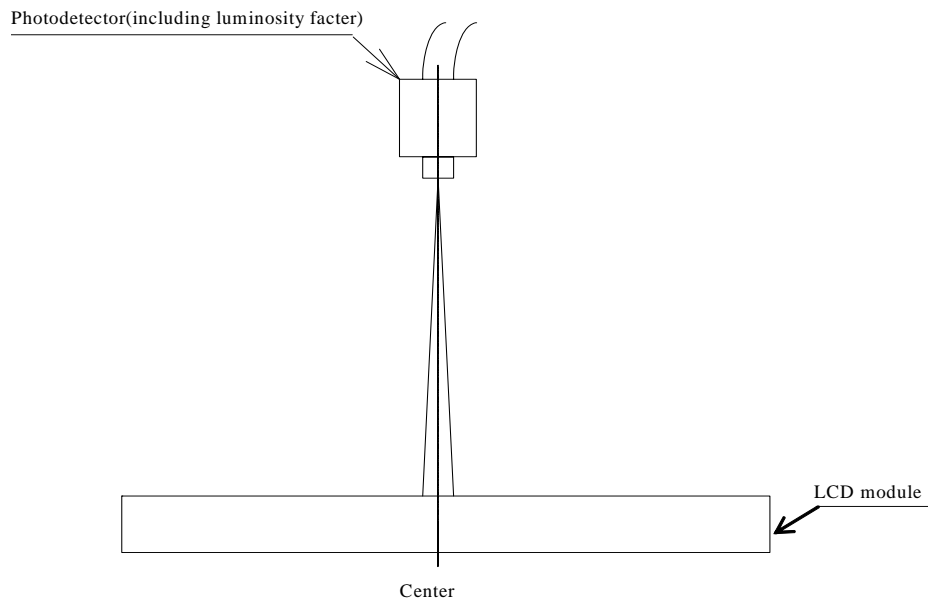

Measuring method for optical characteristics

【Note 11-1】 Viewing angle range is defined as follows.

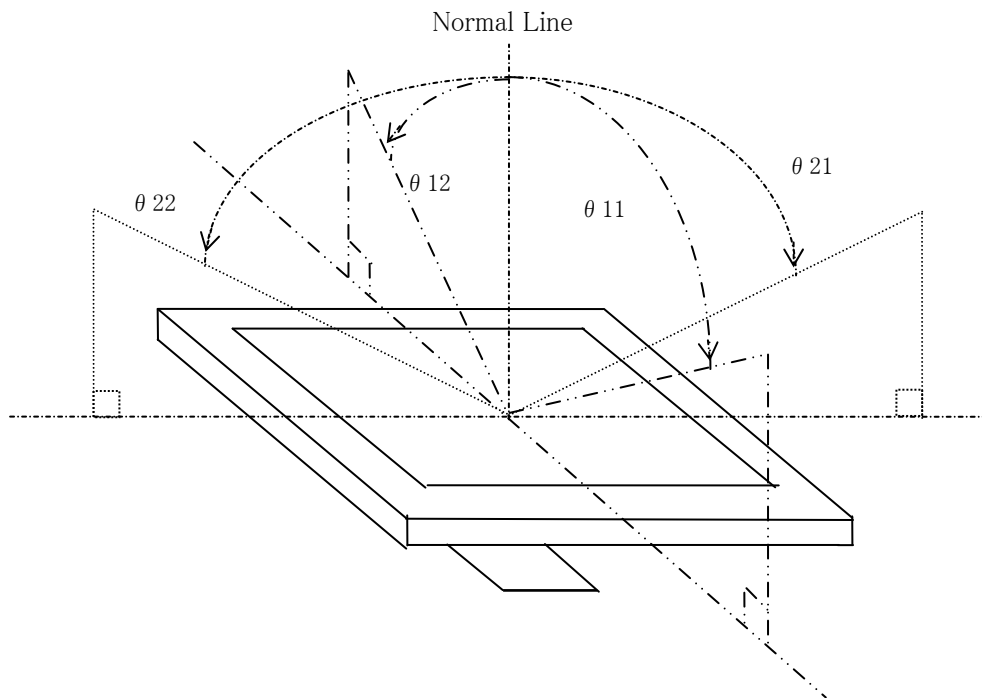

【Note 11-2】 Definition of contrast ratio:

The contrast ratio is defined as the follows:

$$\text{Contrast ratio (CR)} = \frac{\text{Luminance (brightness) with all pixels white}}{\text{Luminance (brightness) with all pixels black}}$$

【Note 11-3】 Definition of response time:

The response time is defined as the following figure and shall be measured by switching the input signal for “black” and “white”

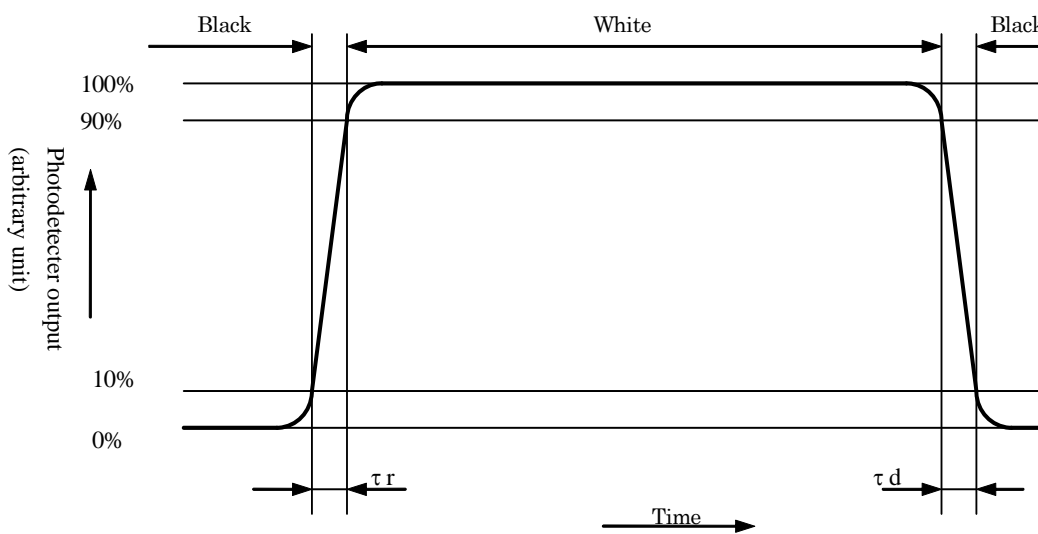

【Note 11-4】 Definition of Uniformity.

$$\text{Uniformity} = \frac{\text{Minimum Brightness}}{\text{Maximum Brightness}} \times 100 (\%)$$

The brightness should be measured on the 9-points as shown in the following figure.

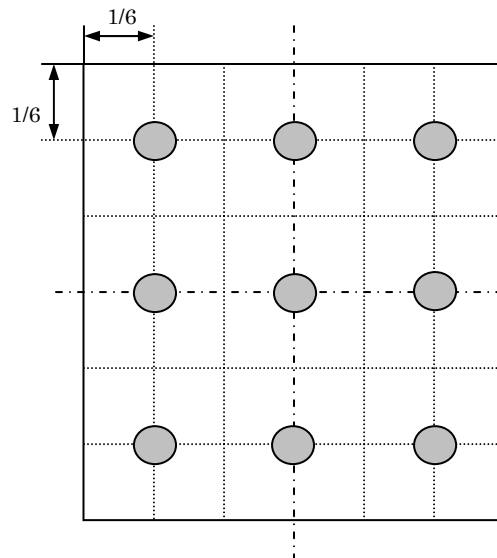

【Note 11-5】 3D mode cross talk

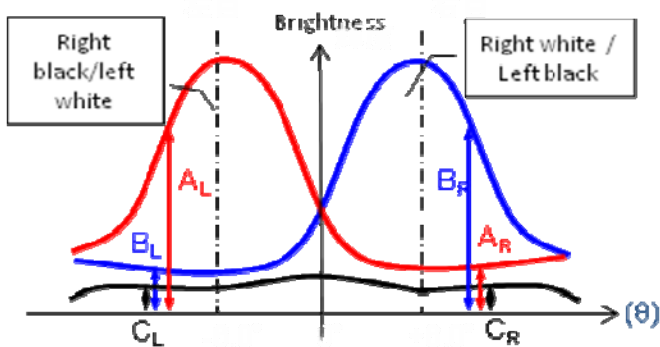

$$\text{Left eye XT}[\%] = \frac{B_L(\theta) - C_L(\theta)}{A_L(\theta) - C_L(\theta)} \times 100$$

$$\text{Right eye XT}[\%] = \frac{A_R(\theta) - C_R(\theta)}{B_R(\theta) - C_R(\theta)} \times 100$$

12. Indication of lot number

The lot number is shown on a label. Attached location is shown in Outline Dimensions.

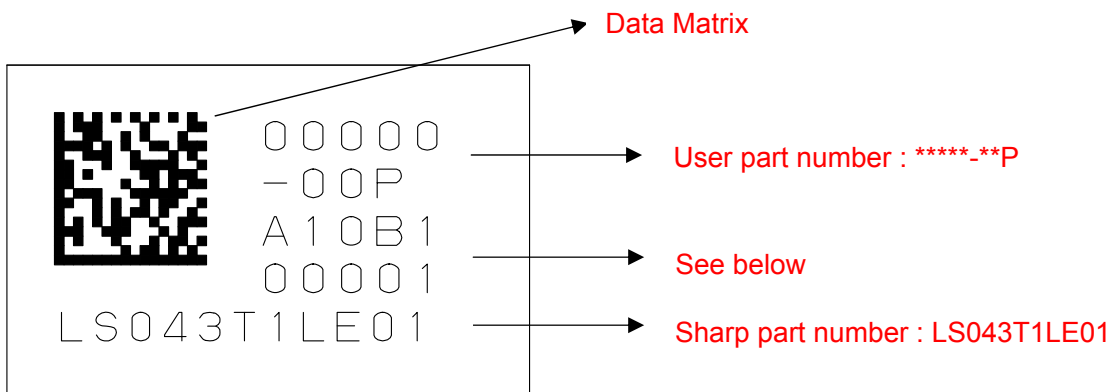

S/N : RRYMD ZZZZZ

RR : Revision code

Y : Manufacture year

M : Manufacture month

D : Manufacture day

Z : Remaining 5 digits of serial number

13. Forwarding form

- (a) Piling number of cartons : TBD deep
- (b) Package quality in one cartons : TBD pcs
- (c) Carton size : TBD mm × TBD mm × TBD mm
- (d) Total mass of 1 carton filled with full modules : approximately TBD kg

Condition for storage

Environment

- (1) Temperature : 0~40°C
- (2) Humidity : 60%RH or less(at 40°C)
- (3) Atmosphere : Harmful gas, such as acid or alkali which erodes electronic components and/or wires, must not be detected.
- (4) Period : about 3 months
- (5) Opening of the package : In order to prevent the LCD module from breakdown by electrostatic charges, please control the room humidity over 50%RH and open the package taking sufficient countermeasures against electrostatic charges, such as earth, etc.

14. Outline dimensions

