

mass integrated

global part distribution • product lifecycle partner
excess inventory management • value-ad service provider



Data sheet provided by Mass Integrated

massintegrated.com • displayalliance.com

Please call +1.978.465.6190
Email: sales@massintegrated.com



ISO 9001: 2008

Mass Integrated complies with all DMCA takedown notices. Please send a formal DMCA Takedown Notice to Mass Integrated Systems, Inc. • 18 Henry Graf Jr. Road, Unit 1 • Newburyport, MA 01950.



Customer :

DATE : 21. Jan. 2010

SAMSUNG TFT-LCD

MODEL : LTA550HJ03

The Information Described in this Specification is Preliminary and can be changed without prior notice

LCD Business

Samsung Electronics Co . , LTD.

MODEL	LTA550HJ03	Doc. No	06-003-S-100121	Page	1 / 26
-------	------------	---------	-----------------	------	--------

Contents



General Description	(3)
General Information	(3)
1. Absolute Maximum Ratings	(4)
2. Optical Characteristics	(5)
3. Electrical Characteristics	(8)
3.1 TFT LCD Module	
3.2 Back Light Unit	
3.3 Inverter Input & Specification	
4. Input Terminal Pin Assignment	(11)
4.1 Input Signal & Power	
4.2 Inverter Input Pin Configuration	
4.3 Inverter Input Power Sequence	
4.4 LVDS Interface	
4.5 Input Signals, Basic Display Colors and Gray Scale of Each Color	
5. Interface Timing	(17)
5.1 Timing Parameters (DE only mode)	
5.2 Timing Diagrams of interface Signal (DE only mode)	
5.3 Power ON/OFF Sequence	
6. Outline Dimension	(19)
7. Packing	(21)
8. Marking & Others	(22)
9. General Precaution	(23)
10.1 Handling	
10.2 Storage	
10.3 Operation	
10.4 Operation Condition Guide	
10.5 Others	

MODEL	LTA550HJ03	Doc. No	06-003-S-100121	Page	2 / 26
-------	------------	---------	-----------------	------	--------

General Description

Description

LTA550HJ03 is a color active matrix liquid crystal display (LCD) that uses amorphous silicon TFT (Thin Film Transistor) as switching components. This model is composed of a TFT LCD panel, a driver circuit and a back light unit. The resolution of a 55.0" is 1920 x 1080 and this model can display up to 1.07 Billion colors with wide viewing angle of 89° or higher in all directions. This panel is intended to support applications to provide an excellent performance for Flat Panel Display such as Home-alone Multimedia TFT-LCD TV and High Definition TV

Features

- RoHS compliance (Pb-free)
- High contrast ratio & aperture ratio with wide color gamut
- SPVA (Super Patterned Vertical Align) mode
- Wide viewing angle ($\pm 178^\circ$)
- High speed response (& Natural Motion (DFR: Double Frame Rate))
- FHD resolution (16:9)
- Low Power consumption
- Edge Type LED (Light Emitted Diode) BLU
- DE (Data Enable) mode
- 4ch LVDS (Low Voltage Differential Signaling) interface (4pixel/clock)

General Information

Items	Specification	Unit	Note
Module Size	1267.6(H _{TYP}) x 744.4(V _{TYP})	mm	±1.0mm
	30.9 (D _{MAX})		
Weight	14,900 (Max)	g	
Pixel Pitch	0.63(H) x 0.63(W)	mm	
Active Display Area	1209.6(H) x 680.4(V)	mm	
Surface Treatment	Haze 0% , Hard Coating 3H		
Display Colors	8 bit + FRC – 1.07 Billion	colors	
Number of Pixels	1920 x 1080	pixel	
Pixel Arrangement	RGB vertical stripe		
Display Mode	Normally Black		
Luminance of White	450 (Typ.)	cd/m ²	

1. Absolute Maximum Ratings

If the condition exceeds maximum ratings, it can cause malfunction or unrecoverable damage to the device.

Item	Symbol	Min.	Max.	Unit	Note
Power Supply Voltage	V_{DD}	GND-0.5	13.2	V	(1)
Dimming Control	Max. Lum	-	5	V	
Storage temperature	T_{STG}	-20	60	°C	(2)
Operating temperature	T_{OPR}	0	50	°C	
Surface temperature	T_{SUR}	0	60	°C	(3)
Shock (non - operating)	X,Y,Z	-	30	G	(4)
Vibration (non - operating)	V_{NOP}	-	1.5	G	(5)

Note (1) $T_a = 25 \pm 2 \text{ }^\circ\text{C}$

(2) Temperature and relative humidity range are shown in the figure below.

- a. 90 % RH Max. ($T_a \leq 39 \text{ }^\circ\text{C}$)
- b. Relative Humidity is 90% or less. ($T_a > 39 \text{ }^\circ\text{C}$)
- c. No condensation

(3) Although abnormal visual problems can be occurred in T_{SUR} range, the polarizer is not damaged in this range.

(4) 11ms, sine wave, one time for $\pm X, \pm Y, \pm Z$ axis

(5) 10-300 Hz, Sweep rate 10min, 30min for X,Y,Z axis

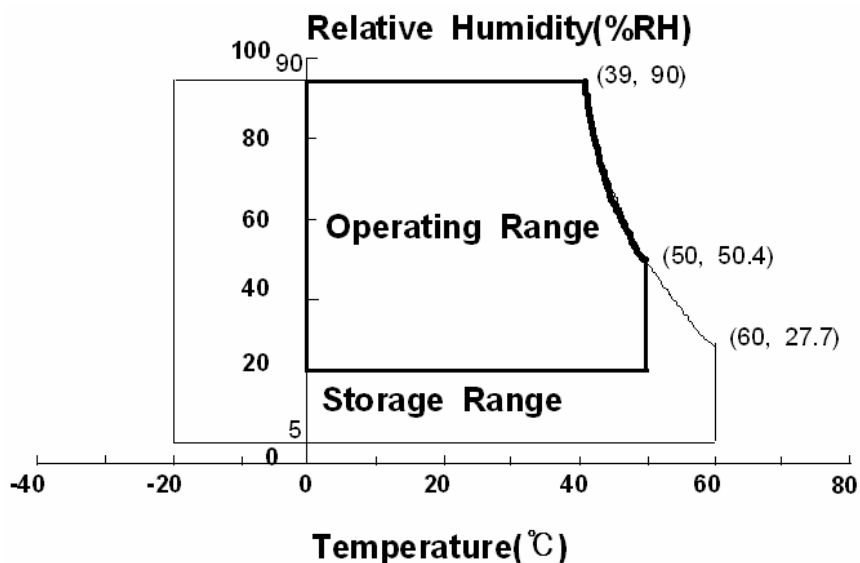

Fig. Temperature and Relative humidity range

2. Optical Characteristics

The optical characteristics should be measured in a dark room or equivalent.

Measuring equipment : TOPCON RD-80S, TOPCON SR-3, ELDIM EZ-Contrast

($T_a = 25 \pm 2^\circ\text{C}$, $V_{DD}=12\text{V}$, $f_v=120\text{Hz}$, $f_{DCLK}=297.0\text{MHz}$, LED Current = 110mA)

Item	Symbol	Condition	Min.	Typ.	Max.	Unit	Note	
Contrast Ratio (Center of screen)	C/R		4,000	5,000	-		(1) SR-3	
Response Time	G-to-G	Tg	-	6	-	msec	(3) RD-80S	
Luminance of White (Center of screen)	Y_L		360	450	-	cd/m ²	(4) SR-3	
Color Chromaticity (CIE 1931)	Red	Rx	Normal $q_{L,R}=0$ $q_{U,D}=0$ Viewing Angle	0.617	TYP. -0.03	TYP. +0.03	(5),(6) SR-3	
		Ry		0.331				
	Green	Gx		0.306				
		Gy		0.635				
	Blue	Bx		0.145				
		By		0.048				
	White	Wx		0.280				
		Wy		0.290				
Color Gamut	-		-	72	-	%	(5) SR-3	
Color Temperature	-		-	10,000	-	K		
Viewing Angle	Hor.	q_L	C/R \geq 10	75	89	-	Degree	(6) EZ-Contrast
		q_R		75	89	-		
	Ver.	q_U		75	89	-		
		q_D		75	89	-		
White Brightness Uniformity (9 Points)	B_{uni}		-	-	25	%	(2) SR-3	

- Test Equipment Setup

The measurement should be executed in a stable, windless and dark room between 40min and 60min after lighting the back light at the given temperature for stabilization of the back light. This should be measured in the center of screen.

Environment condition : $T_a = 25 \pm 2^\circ\text{C}$

MODEL	LTA550HJ03	Doc. No	06-003-S-100121	Page	5 / 26
-------	------------	---------	-----------------	------	--------

Photo detector	Field
SR-3	2°
RD-80S	1°

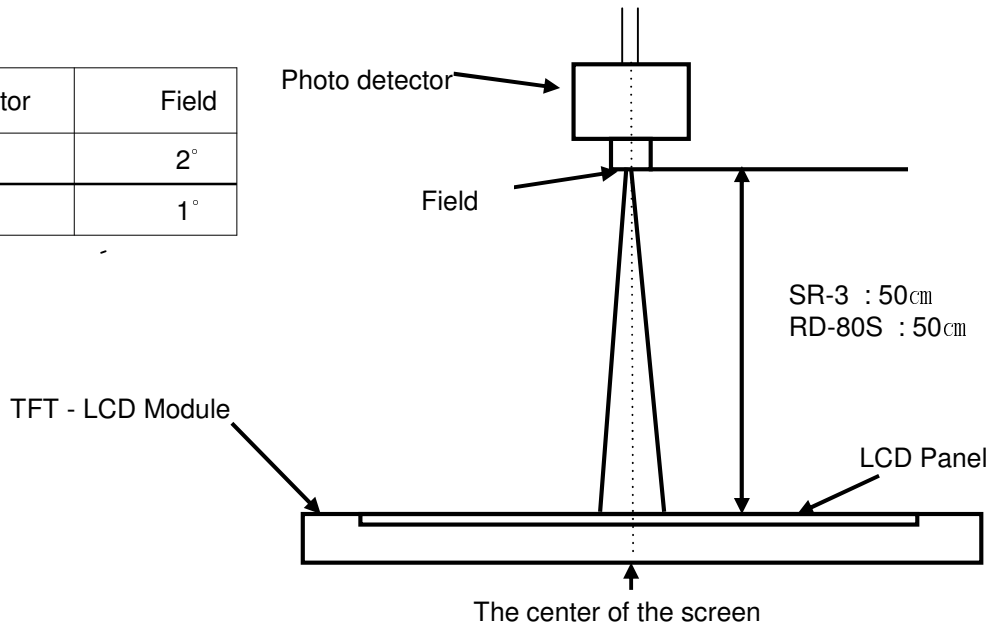

- Definition of test point

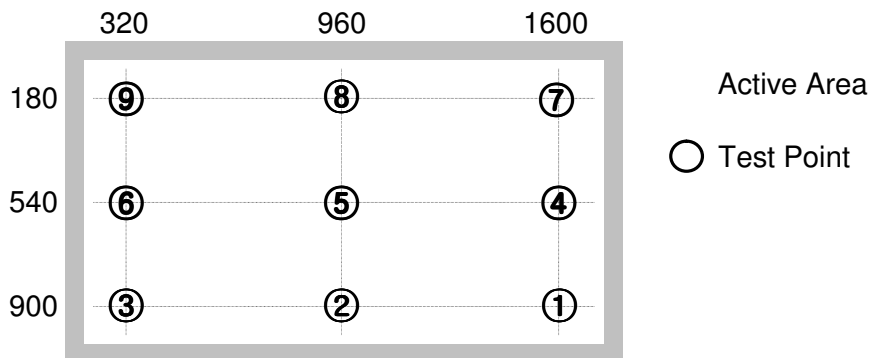

Note (1) Definition of Contrast Ratio (C/R)

: Ratio of gray max (Gmax) & gray min (Gmin) at the center point ⑤ of the panel

$$C/R = \frac{G_{\max}}{G_{\min}}$$

Gmax : Luminance with all pixels white

Gmin : Luminance with all pixels black

Note (2) Definition of 9 points brightness uniformity (Test pattern : Full White)

$$B_{uni} = 100 * \frac{(B_{max} - B_{min})}{B_{max}}$$

Bmax : Maximum brightness

Bmin : Minimum brightness

Note (3) Definition of Response time : Sum of Tr, Tf

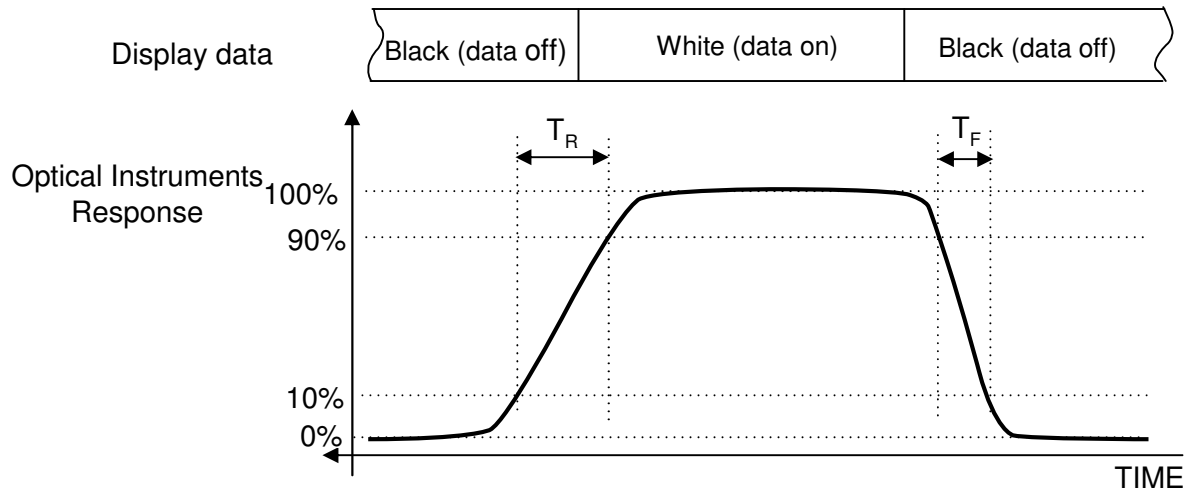

Note (4) Definition of Luminance of White : Luminance of white at center point ⑤

Note (5) Definition of Color Chromaticity (CIE 1931)

Color coordinate of Red, Green, Blue & White at center point ⑤

Note (6) Definition of Viewing Angle

: Viewing angle range (C/R ≥ 10)

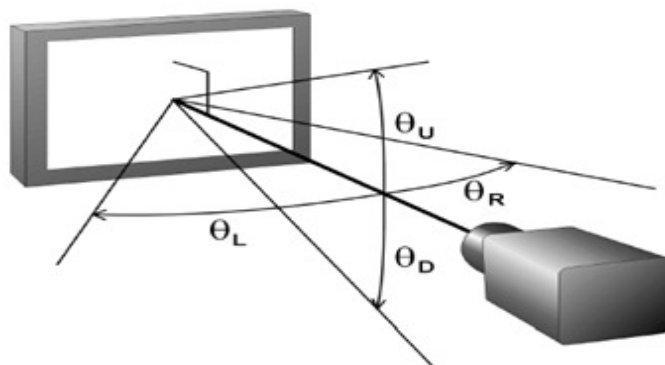

3. Electrical Characteristics

3.1 TFT LCD Module

The connector for display data & timing signal should be connected.

$T_a = 25^\circ\text{C} \pm 2^\circ\text{C}$

Item	Symbol	Min.	Typ.	Max.	Unit	Note
Voltage of Power Supply	V_{DD}	10.8	12.0	13.2	V	(1)
Current of Power Supply	(a) Black	-	640	-	mA	(2),(3)
	(b) White	-	630	-	mA	
	(c) Sub V-stripe	-	1100	1400	mA	
Vsync Frequency	f_V	95.0	120.0	125.0	Hz	
Hsync Frequency	f_H	120.0	135.0	140.0	kHz	
Main Frequency	f_{DCLK}	260.0	297.0	305.0	MHz	
Rush Current	I_{RUSH}	-	-	7	A	(4)

Note (1) The ripple voltage should be controlled under 10% of V_{DD} .

(2) $f_V=120\text{Hz}$, $f_{DCLK} = 297.0\text{MHz}$, $V_{DD} = 12.0\text{V}$, DC Current.

(3) Power dissipation check pattern (LCD Module only)

a) Black Pattern

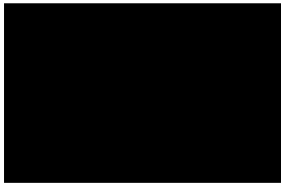

b) White Pattern



c) Sub V-stripe

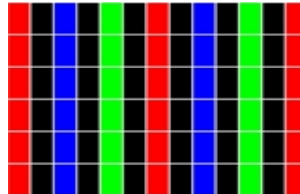

(4) Measurement Conditions

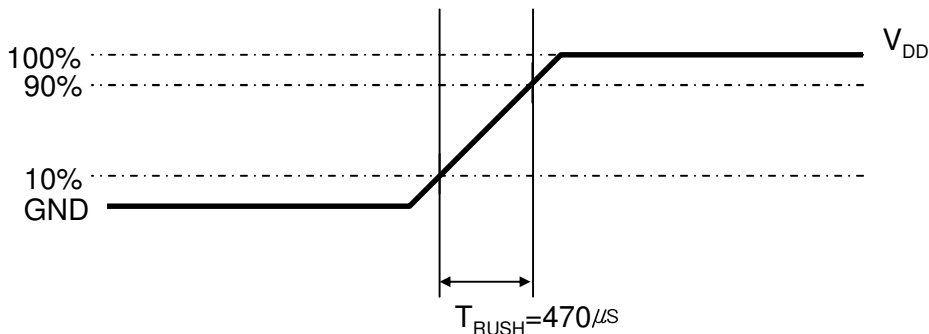

Rush Current I_{RUSH} can be measured when T_{RUSH} is $470 \mu\text{s}$.

3.2 Back Light Unit

The back light unit contains Edge type White LEDs (Light Emitting Diode)

Ta=25 ± 2°C

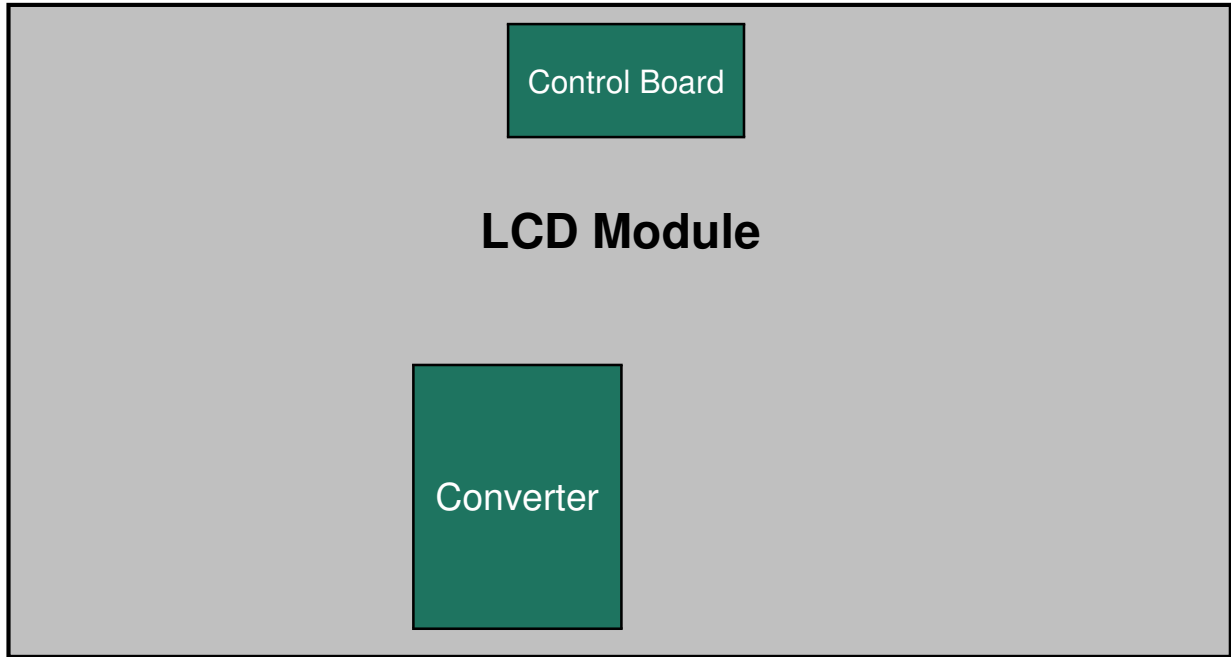

Item	Symbol	Min.	Typ.	Max.	Unit	Note
Operating Life Time	Hr	-	45,000	-	Hour	(1)

Note (1) It is defined as the time to take until the brightness reduces to 50% of its original value.

[Operating condition : Ta = 25±2°C, For LED Package only.]

(2) SSC LED Test Condition :110mA / 650hr / Tj = 70°C

3.3 Inverter Input Condition & Specification

Items	Symbol	Conditions	Specifications			Unit	Note
			Min.	Typ.	Max.		
Input Voltage	V _{in}	-	22	24	26	V	Ta=25±2 °C (3)
Input Current	I _{OVER}	V _{in} =24.0V V _{dim} =3.3V	-	4.81	5.49	A	(1)
	I _{SAT}		-	4.50	4.72		(2)
LED Current	I _{O,MAX}	V _{dim} =3.3 V	105	110	115	mArms	(2)
Backlight On/Off	ON	V _{in} =24.0 V	2.4	-	5.25	V	(3)
	OFF	V _{in} =24.0 V	0	-	0.8		
Dimming Control	V _{DIM}	Max Lum	3.3	-	-	V	(3)
		Min. Lum	-	-	0		
PWM Voltage	V _{PWM}	Max	3.0	-	5.0	V	(3)
		Min	0.0	-	0.4		
PWM Frequency	F _{PWM}	V _{in} =24.0 V	95	-	185	Hz	
PWM Duty	Duty	V _{in} =24.0 V	0	-	100	%	(4)

Note) Power Consumption is measured when 450 [cd/m] of luminance which is the typical luminance.

LED Current is measured at the point before LED.

- (1) Max Value of the Power Consumption is measured during initial turn on time* of the backlight
- (2) Max Value of the Power Consumption is measured after 60 min warm-up.
- (3) The ripple voltage should be controlled under 10% of Input Signal
- (4) Duty = On/(On+Off) * 100

* Initial turn-on time : From 0sec to 60min after turn-on

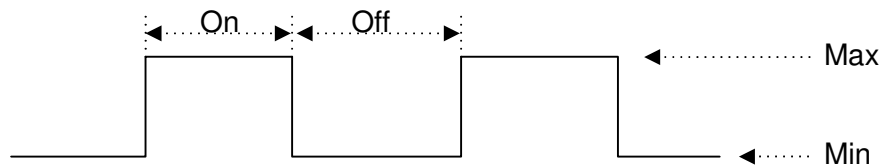

4. Input Terminal Pin Assignment

4.1.1 Input Signal & Power

Connector : FI-RE41S-HF (JAE/UJU)

Pin	Description		Pin	Symbol	Description
1	Vdd(12V)		21	ODD LVDS SIGNAL	Rx1[3]P
2	Vdd(12V)		22		Rx1[4]N
3	Vdd(12V)		23		Rx1[4]P
4	Vdd(12V)		24		GND
5	Vdd(12V)		25		Rx3[0]N
6	No Connection		26		Rx3[0]P
7	GND		27		Rx3[1]N
8	GND		28		Rx3[1]P
9	GND		29		Rx3[2]N
10	ODD LVDS SIGNAL	Rx1[0]N	30		Rx3[2]P
11		Rx1[0]P	31		GND
12		Rx1[1]N	32		Rx3CLK-
13		Rx1[1]P	33		Rx3CLK+
14		Rx1[2]N	34		GND
15		Rx1[2]P	35		Rx3[3]N
16		GND	36		Rx3[3]P
17		Rx1CLK-	37		Rx3[4]N
18		Rx1CLK+	38		Rx3[4]P
19		GND	39		GND
20	Rx1[3]N	40	No Connection		
		41	No Connection		

Note) No Connection: This PINS are only used for SAMSUNG internal using.

4.1.2 Input Signal & Power

Connector : FI-RE51S-HF (JAE/UJU)

Pin	Description	Pin	Description
1	Vdd(12V)	26	Rx4[0]P
2	Vdd(12V)	27	Rx4[1]N
3	Vdd(12V)	28	Rx4[1]P
4	Vdd(12V)	29	Rx4[2]N
5	Vdd(12V)	30	Rx4[2]P
6	No Connection	31	GND
7	GND	32	Rx4CLK-
8	GND	33	Rx4CLK+
9	GND	34	GND
10	Rx2[0]N	35	Rx4[3]N
11	Rx2[0]P	36	Rx4[3]P
12	Rx2[1]N	37	Rx4[4]N
13	Rx2[1]P	38	Rx4[4]P
14	Rx2[2]N	39	GND
15	Rx2[2]P	40	No Connection
16	GND	41	No Connection
17	Rx2CLK-	42	No Connection
18	Rx2CLK+	43	No Connection
19	GND	44	No Connection
20	Rx2[3]N	45	LVDS Option * Note(1)
21	Rx2[3]P	46	No Connection
22	Rx2[4]N	47	No Connection
23	Rx2[4]P	48	No Connection
24	GND	49	No Connection
25	Rx4[0]N	50	No Connection
		51	No Connection

NOTE) No connection : This Pins are only used for SAMSUNG internal using

Note) Pin number starts from Right side

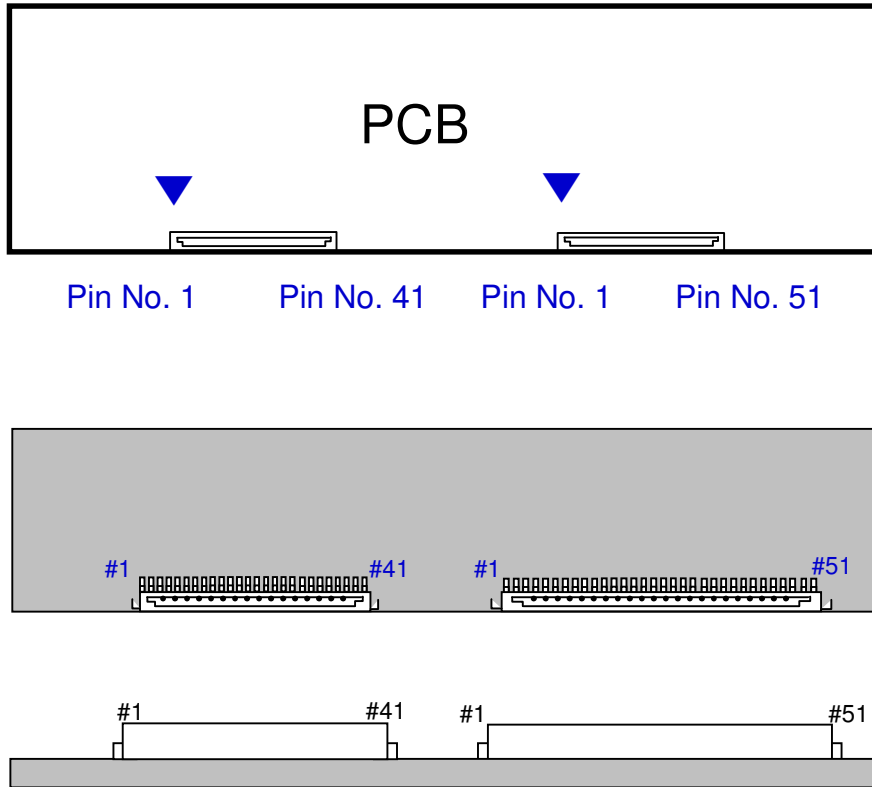
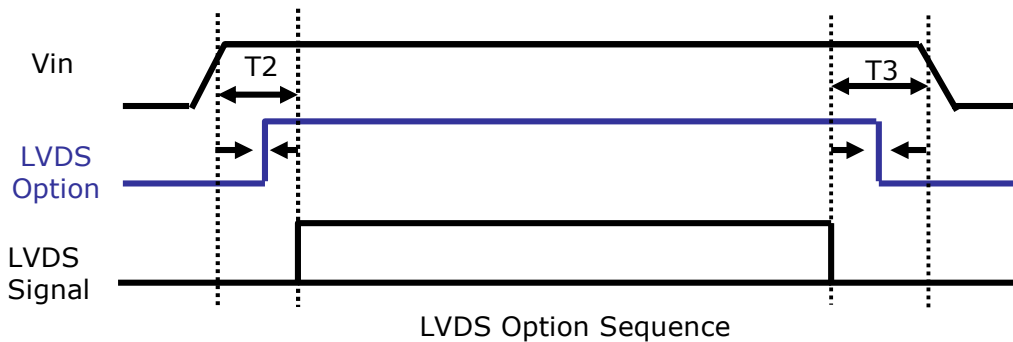

Fig. Connector diagram

- a. All GND pins should be connected together and also be connected to the LCD's metal chassis.
- b. All power input pins should be connected together.
- c. All NC pins should be separated from other signal or power.

Note(1) LVDS OPTION : If this PIN HIGH (3.3V) → Normal LVDS format
 LOW (GND) → JEIDA LVDS format

SEQUENCE : On = VDD(T1) → LVDS Option → Interface Signal(T2)
 OFF = Interface Signal(T3) → LVDS Option → VDD



4.2. Inverter Input Pin Configuration

Connector : Yeon-Ho, 20022WR-14B1

Pin No.	Pin Configuration(FUNCTION)
	Master
1	24 V
2	24 V
3	24 V
4	24 V
5	24 V
6	GND
7	GND
8	GND
9	GND
10	GND
11	Error Out
12	Backlight On /Off [ON:2.4 - 5.25 V, OFF: 0 - 0.8 V]
13	Dimming Control [0V:Min, 3.3V:Max] *Note(1)
14	External PWM [20~100%] *Note(1)

Note(1) If use Dimming Control, Pin 14 Must be N.C

If use External PWM, Pin 13 Must be N.C

4.3. Inverter Input Power Sequence

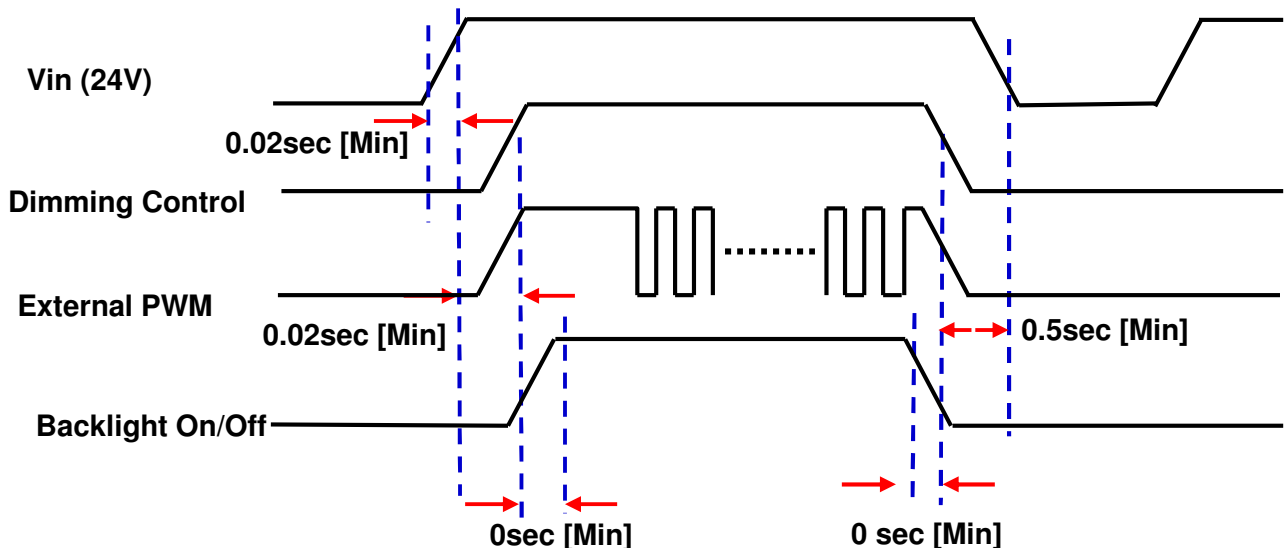

Note) SEQUENCE : On = Vin(24V) > Dimming Control ≥ Backlight On/off
 OFF = Backlight On/Off ≥ Dimming Control > Vin(24V)

4.4 LVDS Interface

- LVDS Receiver : Tcon (merged)
- Data Format (JEIDA & Normal)

	LVDS pin	JEIDA -DATA	Normal -DATA
TxOUT/RxIN0	TxIN/RxOUT0	R4	R0
	TxIN/RxOUT1	R5	R1
	TxIN/RxOUT2	R6	R2
	TxIN/RxOUT3	R7	R3
	TxIN/RxOUT4	R8	R4
	TxIN/RxOUT6	R9	R5
	TxIN/RxOUT7	G4	G0
TxOUT/RxIN1	TxIN/RxOUT8	G5	G1
	TxIN/RxOUT9	G6	G2
	TxIN/RxOUT12	G7	G3
	TxIN/RxOUT13	G8	G4
	TxIN/RxOUT14	G9	G5
	TxIN/RxOUT15	B4	B0
	TxIN/RxOUT18	B5	B1
TxOUT/RxIN2	TxIN/RxOUT19	B6	B2
	TxIN/RxOUT20	B7	B3
	TxIN/RxOUT21	B8	B4
	TxIN/RxOUT22	B9	B5
	TxIN/RxOUT24	HSYNC	HSYNC
	TxIN/RxOUT25	VSYNC	VSYNC
	TxIN/RxOUT26	DEN	DEN
TxOUT/RxIN3	TxIN/RxOUT27	R2	R6
	TxIN/RxOUT5	R3	R7
	TxIN/RxOUT10	G2	G6
	TxIN/RxOUT11	G3	G7
	TxIN/RxOUT16	B2	B6
	TxIN/RxOUT17	B3	B7
	TxIN/RxOUT23	RESERVED	RESERVED
TxOUT/RxIN4	TxIN/RxOUT28	R0	R8
	TxIN/RxOUT29	R1	R9
	TxIN/RxOUT30	G0	G8
	TxIN/RxOUT31	G1	G9
	TxIN/RxOUT32	B0	B8
	TxIN/RxOUT33	B1	B9
	TxIN/RxOUT34	RESERVED	RESERVED

4.5 Input Signals, Basic Display Colors and Gray Scale of Each Color

COLOR	DISPLAY (8bit)	DATA SIGNAL																												GRAY SCALE LEVEL	
		RED									GREEN									BLUE											
		R0	R1	R2	R3	R4	R5	R6	R7	R8	R9	G0	G1	G2	G3	G4	G5	G6	G7	G8	G9	B0	B1	B2	B3	B4	B5	B6	B7		B8
BASIC COLOR	BLACK	0	0	0	0	0	0	0	0	0	0	0	0	0	0	0	0	0	0	0	0	0	0	0	0	0	0	0	0	-	
	BLUE	0	0	0	0	0	0	0	0	0	0	0	0	0	0	0	0	0	0	0	0	1	1	1	1	1	1	1	1	1	-
	GREEN	0	0	0	0	0	0	0	0	0	0	1	1	1	1	1	1	1	1	1	1	0	0	0	0	0	0	0	0	0	-
	CYAN	0	0	0	0	0	0	0	0	0	0	1	1	1	1	1	1	1	1	1	1	1	1	1	1	1	1	1	1	1	-
	RED	1	1	1	1	1	1	1	1	1	1	0	0	0	0	0	0	0	0	0	0	0	0	0	0	0	0	0	0	0	-
	MAGENTA	1	1	1	1	1	1	1	1	1	1	0	0	0	0	0	0	0	0	0	0	0	1	1	1	1	1	1	1	1	-
	YELLOW	1	1	1	1	1	1	1	1	1	1	1	1	1	1	1	1	1	1	1	1	0	0	0	0	0	0	0	0	0	-
	WHITE	1	1	1	1	1	1	1	1	1	1	1	1	1	1	1	1	1	1	1	1	1	1	1	1	1	1	1	1	1	-
GRAY SCALE OF RED	BLACK	0	0	0	0	0	0	0	0	0	0	0	0	0	0	0	0	0	0	0	0	0	0	0	0	0	0	0	0	R0	
	DARK ↑	1	0	0	0	0	0	0	0	0	0	0	0	0	0	0	0	0	0	0	0	0	0	0	0	0	0	0	0	R1	
		0	1	0	0	0	0	0	0	0	0	0	0	0	0	0	0	0	0	0	0	0	0	0	0	0	0	0	0	R2	
		:	:	:	:	:	:	:	:	:	:	:	:	:	:	:	:	:	:	:	:	:	:	:	:	:	:	:	:	:	R3~R1020
	LIGHT ↓	:	:	:	:	:	:	:	:	:	:	:	:	:	:	:	:	:	:	:	:	:	:	:	:	:	:	:	:	:	
		1	0	1	1	1	1	1	1	1	1	0	0	0	0	0	0	0	0	0	0	0	0	0	0	0	0	0	0	R1021	
		0	1	1	1	1	1	1	1	1	1	0	0	0	0	0	0	0	0	0	0	0	0	0	0	0	0	0	0	R1022	
	RED	1	1	1	1	1	1	1	1	1	1	0	0	0	0	0	0	0	0	0	0	0	0	0	0	0	0	0	0	R1023	
GRAY SCALE OF GREEN	BLACK	0	0	0	0	0	0	0	0	0	0	0	0	0	0	0	0	0	0	0	0	0	0	0	0	0	0	0	0	G0	
	DARK ↑	0	0	0	0	0	0	0	0	0	0	1	0	0	0	0	0	0	0	0	0	0	0	0	0	0	0	0	0	G1	
		0	0	0	0	0	0	0	0	0	0	0	1	0	0	0	0	0	0	0	0	0	0	0	0	0	0	0	0	G2	
		:	:	:	:	:	:	:	:	:	:	:	:	:	:	:	:	:	:	:	:	:	:	:	:	:	:	:	:	G3~G1020	
	LIGHT ↓	:	:	:	:	:	:	:	:	:	:	:	:	:	:	:	:	:	:	:	:	:	:	:	:	:	:	:	:	:	
		0	0	0	0	0	0	0	0	0	0	1	0	1	1	1	1	1	1	1	1	0	0	0	0	0	0	0	0	G1021	
		0	0	0	0	0	0	0	0	0	0	0	1	1	1	1	1	1	1	1	1	0	0	0	0	0	0	0	0	G1022	
	GREEN	0	0	0	0	0	0	0	0	0	0	1	1	1	1	1	1	1	1	1	1	0	0	0	0	0	0	0	0	G1023	
GRAY SCALE OF BLUE	BLACK	0	0	0	0	0	0	0	0	0	0	0	0	0	0	0	0	0	0	0	0	0	0	0	0	0	0	0	0	B0	
	DARK ↑	0	0	0	0	0	0	0	0	0	0	0	0	0	0	0	0	0	0	0	0	1	0	0	0	0	0	0	0	B1	
		0	0	0	0	0	0	0	0	0	0	0	0	0	0	0	0	0	0	0	0	0	1	0	0	0	0	0	0	B2	
		:	:	:	:	:	:	:	:	:	:	:	:	:	:	:	:	:	:	:	:	:	:	:	:	:	:	:	:	B3~B1020	
	LIGHT ↓	:	:	:	:	:	:	:	:	:	:	:	:	:	:	:	:	:	:	:	:	:	:	:	:	:	:	:	:	:	
		0	0	0	0	0	0	0	0	0	0	0	0	0	0	0	0	0	0	0	0	0	1	0	1	1	1	1	1	B1021	
		0	0	0	0	0	0	0	0	0	0	0	0	0	0	0	0	0	0	0	0	0	1	1	1	1	1	1	1	B1022	
	BLUE	0	0	0	0	0	0	0	0	0	0	0	0	0	0	0	0	0	0	0	0	0	1	1	1	1	1	1	1	B1023	

Note) Definition of Gray :

Rn : Red Gray, Gn : Green Gray, Bn : Blue Gray (n = Gray level)

Input Signal : 0 = Low level voltage, 1 = High level voltage

5. Interface Timing

5.1 Timing Parameters (DE mode)

SIGNAL	ITEM	SYMBOL	MIN.	TYP.	MAX.	Unit	NOTE
Clock	Frequency	$1/T_C$	260.0	297.0	305.0	MHz	-
Hsync		F_H	120.0	135.0	140.0	KHz	-
Vsync		F_V	95.0	120.0	125.0	Hz	-
Vertical Display Term	Active Display Period	T_{VD}	-	1080	-	Lines	-
	Vertical Total	T_V	1092	1125	1380	Lines	-
Horizontal Display Term	Active Display Period	T_{HD}	-	1920	-	Clocks	-
	Horizontal Total	T_H	2092	2200	2348	clocks	-

Note) This product is DE mode. The Hsync & Vsync signal must be inputted

- (1) Test Point : TTL control signal and CLK at LVDS Tx input terminal in system
- (2) Internal VDD = 3.3V
- (3) Spread spectrum
 - Modulation rate (max) : $\pm 1.5 \%$
 - Modulation Frequency : under 300KHz

5.2 Timing diagrams of interface signal (DE mode)

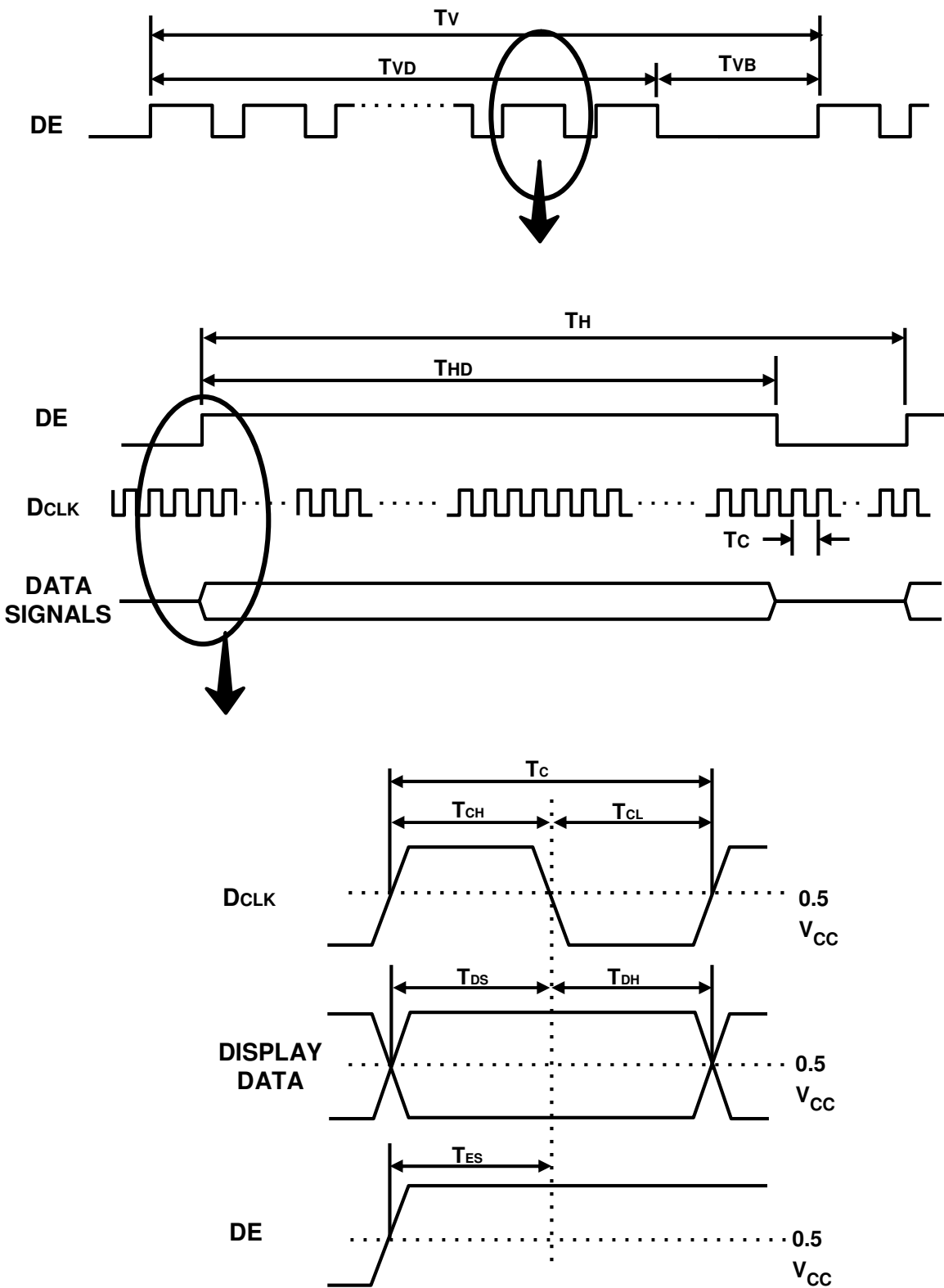

5.3 Power ON/OFF Sequence

To prevent a latch-up or DC operation of the LCD Module, the power on/off sequence should be as the diagram below.

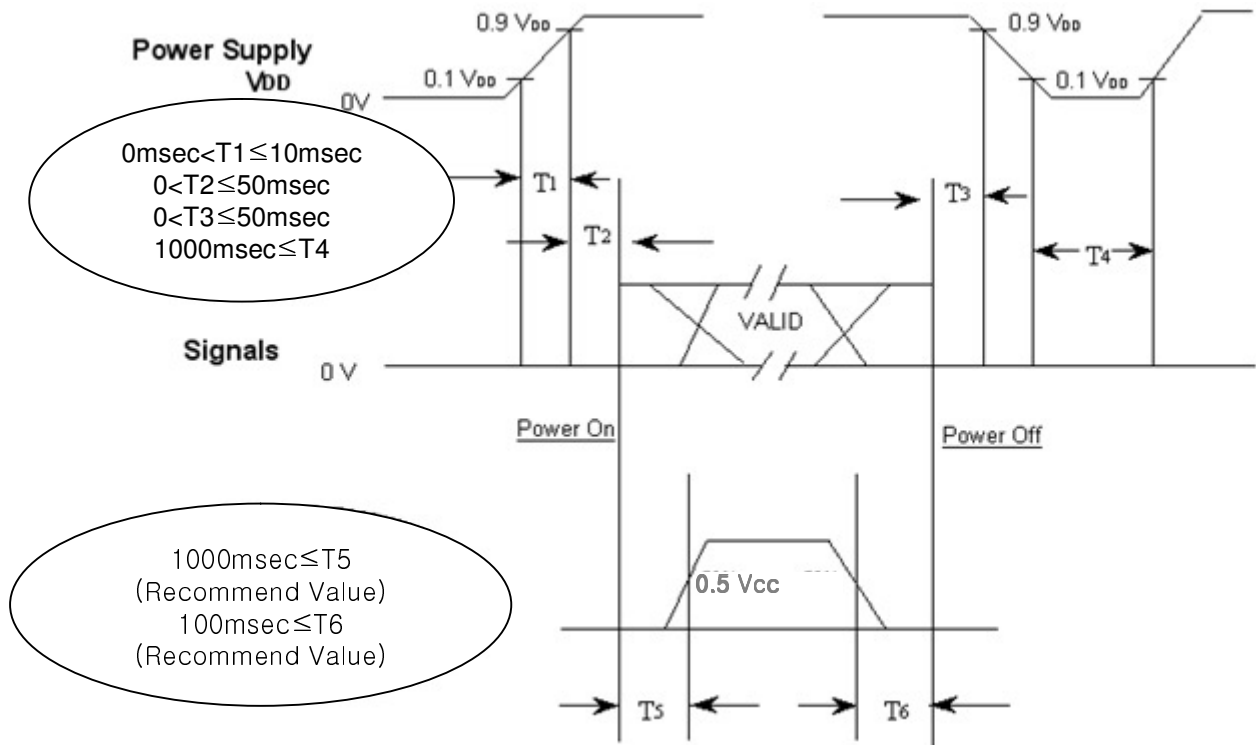

- $T1$: V_{DD} rising time from 10% to 90%
- $T2$: The time from V_{DD} to valid data at power ON.
- $T3$: The time from valid data off to V_{DD} off at power Off.
- $T4$: V_{DD} off time for Windows restart
- $T5$: The time from valid data to B/L enable at power ON.
- $T6$: The time from valid data off to B/L disable at power Off.

- The supply voltage of the external system for the Module input should be the same as the definition of V_{DD} .
- Apply the lamp voltage within the LCD operation range. When the back light turns on before the LCD operation or the LCD turns off before the back light turns off, the display may momentarily show abnormal screen.
- In case of $V_{DD} = \text{off level}$, please keep the level of input signals low or keep a high impedance.
- $T4$ should be measured after the Module has been fully discharged between power off and on period.
- Interface signal should not be kept at high impedance when the power is on.
- In Case $T5$ is less than 1000msec and $T6$ is less than 100msec, Garbage Display can be seen. (It is not related to electrical function issue, Just for recommendation to prevent Garbage Display)

MODEL	LTA550HJ03	Doc. No	06-003-S-100121	Page	19 / 26
-------	------------	---------	-----------------	------	---------

6. Outline Dimension- Front



TBD

MODEL	LTA550HJ03	Doc. No	06-003-S-100121	Page	20 / 26
-------	------------	---------	-----------------	------	---------

6. Outline Dimension- Rear



TBD

7. PACKING

7.1 CARTON (Internal Package)

(1) Packing Form

Corrugated fiberboard box and corrugated cardboard as shock absorber

(2) Packing Method

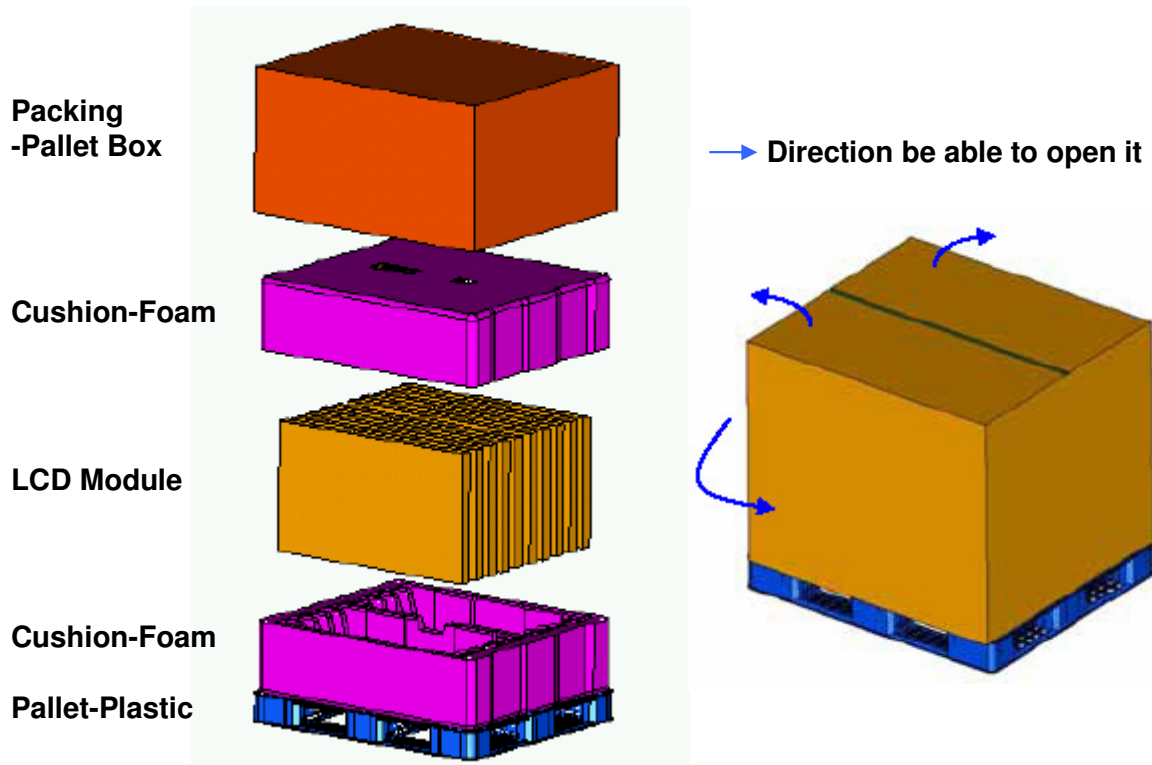

7.2 Packing Specification

Item	Specification	Remark
LCD Packing	13ea / (Packing-Pallet Box)	1. 14.9 kg / LCD (13ea) 2. 15.3 Kg / Cushion-pallet (2ea) 3. 10.5 Kg / Packing-Pallet Box (1ea) 4. Cushion-pallet Material : EPS 5. Packing-Pallet Box Material : DW4
Pallet	1Box / Pallet	1. Pallet weight = 10kg
Packing Direction	Vertical	
Total Pallet Size	H x V x height	1270mm(H) x 1150mm(V) x 995mm(height)
Total Pallet Weight	229.5 kg	Pallet(10kg) + Module (193.7 kg) + Cushion (up + bottom =15.3kg) + Pallet-BOX(10.5kg)

8. MARKING & OTHERS

A nameplate bearing followed by is affixed to a shipped product at the specified location on each product.

- (1) Part number : LTA550HJ03
- (2) Revision: Three letters
- (3) Lot number : X X X X XXX XX X

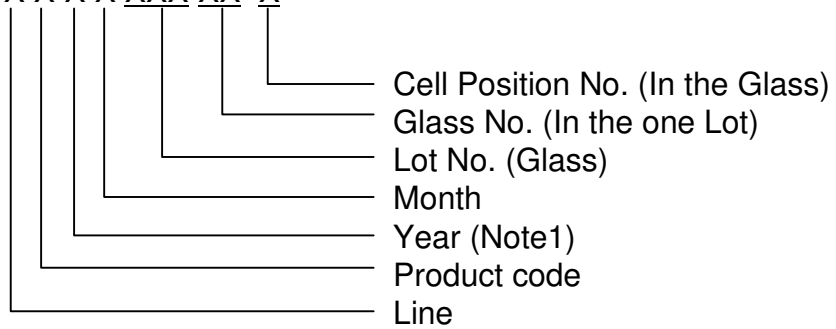

(4) Nameplate Indication

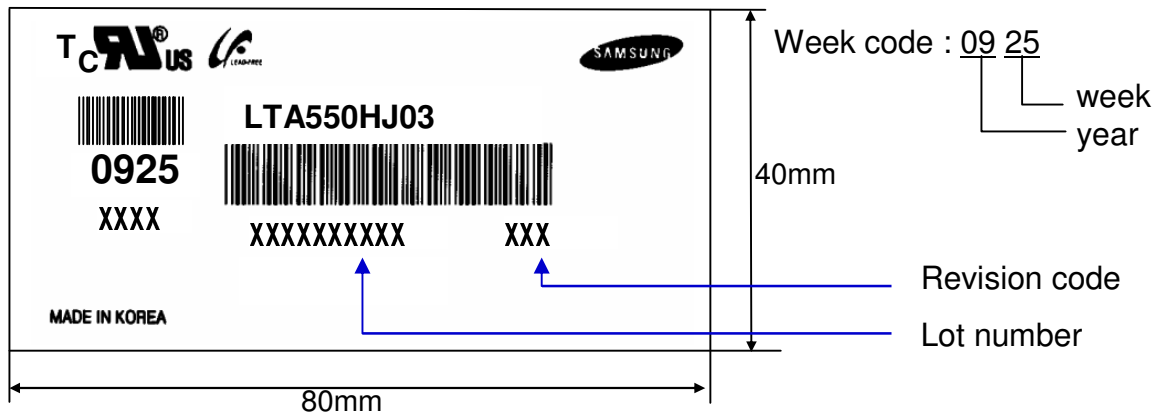

(5) Packing box attach

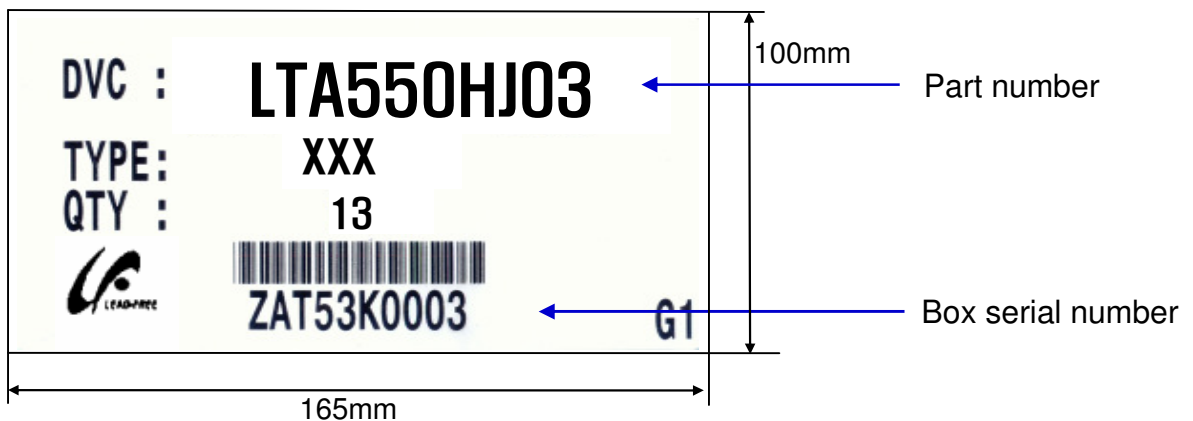

(6) Others

- 1. After service part

Lamps cannot be replaced because of the narrow bezel structure.

MODEL	LTA550HJ03	Doc. No	06-003-S-100121	Page	23 / 26
-------	------------	---------	-----------------	------	---------

9. General Precautions

9.1 Handling

- (a) When the Module is assembled, it should be attached to the system firmly using all mounting holes. Be careful not to twist and bend the Module.
- (b) Because the inverter use high voltage, it should be disconnected from power before it is assembled or disassembled.
- (c) Refrain from strong mechanical shock and / or any force to the Module.
In addition to damage, this may cause improper operation or damage to the Module and CCFT back light.
- (d) Note that polarizers are very fragile and could be damage easily.
Do not press or scratch the surface harder than a HB pencil lead.
- (e) Wipe off water droplets or oil immediately. If you leave the droplets for a long time, staining or discoloration may occur.
- (f) If the surface of the polarizer is dirty, clean it using absorbent cotton or soft cloth.
- (g) Desirable cleaners are water, IPA(Isopropyl Alcohol) or Hexane.
Do not use Ketone type materials(ex. Acetone), Ethyl alcohol, Toluene, Ethyl acid or Methyl chloride. It might permanent damage to the polarizer due to chemical reaction.
- (h) If the liquid crystal material leaks from the panel, it should be kept away from the eyes or mouth . In case of contact with hands, legs or clothes, it must be washed away with soap thoroughly.
- (i) Protect the module from Electrostatic discharge. Otherwise the ASIC IC or semiconductor would be damaged.
- (j) Use finger-stalls with soft gloves in order to keep display clean during the incoming inspection and assembly process.
- (k) Do not disassemble the Module.
- (l) Do not disassemble shield case of inverter & LVDS board
- (m) Do not connect N.C pins. (Samsung internal use only)
- (n) Protection film for polarizer on the Module should be slowly peeled off just before use so that the electrostatic charge can be minimized. Must put on antistatic glove while handling a module
- (o) Pins of I/F connector should not be touched directly with bare hands.

9.2 Storage

- (a) Do not leave the Module in high temperature, and high humidity for a long time. It is highly recommended to store the Module with temperature from 0 to 35 °C and relative humidity of less than 70%.
- (b) Do not store the TFT-LCD Module in direct sunlight.
- (c) The Module should be stored in a dark place. It is prohibited to apply sunlight or fluorescent light in storing.

9.3 Operation

- (a) Do not connect or disconnect the Module in the "Power On" condition.
- (b) Power supply should always be turned on/off by the "Power on/off sequence"
- (c) Module has high frequency circuits. Sufficient suppression to the electromagnetic interference should be done by system manufacturers. Grounding and shielding methods may be important to minimize the interference.
- (d) The cable between the back light connector and its inverter power supply should be connected directly with a minimized length. A longer cable between the back light and the inverter may cause lower luminance of lamp(CCFT) and may require higher startup voltage(Vs).

9.4 Operation Condition Guide

- (a) The LCD product should be operated under normal conditions.
Normal condition is defined as below;
 - Temperature : 20 ± 15 °C
 - Humidity : 55 ± 20 %
 - Display pattern : continually changing pattern (Not stationary)
- (b) If the product will be used in extreme conditions such as high temperature, humidity, display patterns or operation time etc., It is strongly recommended to contact SEC for Application engineering advice. Otherwise, its reliability and function may not be guaranteed. Extreme conditions are commonly found at Airports, Transit Stations, Banks, Stock market, and Controlling systems.

9.5 Others



- (a) Ultra-violet ray filter is necessary for outdoor operation.
- (b) Avoid condensation of water. It may result in improper operation or disconnection of electrode.
- (c) Do not exceed the absolute maximum rating value. (supply voltage variation, input voltage variation, variation in part contents and environmental temperature, and so on)
Otherwise the Module may be damaged.
- (d) If the Module keeps displaying the same pattern for a long period of time, the image may be "sticked" to the screen.
To avoid image sticking, it is recommended to use a screen saver.
- (e) This Module has its circuitry PCB's on the rear side and should be handled carefully in order not to be stressed.
- (f) Please contact SEC in advance when you display the same pattern for a long time.

MODEL	LTA550HJ03	Doc. No	06-003-S-100121	Page	26 / 26
-------	------------	---------	-----------------	------	---------