

# mass integrated

global part distribution • product lifecycle partner  
excess inventory management • value-ad service provider



Data sheet provided by Mass Integrated

[massintegrated.com](http://massintegrated.com) • [displayalliance.com](http://displayalliance.com)

Please call +1.978.465.6190  
Email: [sales@massintegrated.com](mailto:sales@massintegrated.com)



ISO 9001: 2008

Mass Integrated complies with all DMCA takedown notices. Please send a formal DMCA Takedown Notice to Mass Integrated Systems, Inc. • 18 Henry Graf Jr. Road, Unit 1 • Newburyport, MA 01950.

TO :

DATE : November. 28. 2007

*SAMSUNG TFT-LCD*

**MODEL NO. : LTE430WQ-F0C**

Customer Approval

---

---

---

---

*Any Modification of Spec is not allowed without SEC's permission.*

Approved by :                     **S.C. OH**                    

**Mobile Display Business Team**  
**LCD Business**  
**Samsung Electronics Co., LTD.**



**Revision History**

| Date          | Rev. No. | Page | Summary                   |
|---------------|----------|------|---------------------------|
| Aug. 20. 2007 | 000      |      | Rev.000 was first issues. |

**Contents**

|  |       |      |
|--|-------|------|
| General Description  | ----- | (4)  |
| 1. Absolute Maximum Ratings  | ----- | (6)  |
| 1.1 Absolute Ratings Of Environment                                  |       |      |
| 1.2 Electrical Absolute Ratings                                      |       |      |
| 2. Optical Characteristics   | ----- | (8)  |
| 3. Electrical Characteristics  | ----- | (12) |
| 3.1 TFT-LCD Module   |       |      |
| 3.2 Back-light Unit  |       |      |
| 4. Touch Screen Panel Specification                                  | ----- | (14) |
| 4.1 Electrical Characteristics                                       |       |      |
| 4.2 Mechanical & Reliability Characteristics                         |       |      |
| 4.3 Design Guide   |       |      |
| 5. Block Diagram   | ----- | (17) |
| 5.1 TFT-LCD Module(Interface System Structure) with Back Light Unit  |       |      |
| 5.2 Touch Screen Panel   |       |      |
| 5.3 Back-light Unit  |       |      |
| 6. Input Terminal Pin Assignment                                     | ----- | (19) |
| 6.1 Input Signal & Power   |       |      |
| 6.2 Touch screen panel   |       |      |
| 6.3 Input Signal, Basic Display colors and Gray Scale of Each Colors |       |      |
| 6.4 Pixel Format   |       |      |
| 7. Interface Timing  | ----- | (22) |
| 8. Power On/Off Sequence   | ----- | (27) |
| 9. Outline Dimension   | ----- | (28) |
| 10. Packing  | ----- | (29) |
| 11. Marking & Others   | ----- | (30) |
| 12. General Precaution   | ----- | (31) |
| 12.1 Handling  |       |      |
| 12.2 Storage   |       |      |
| 12.3 Operation   |       |      |
| 12.4 Others  |       |      |
| 13. Reliability Test Result  | ----- | (33) |

## General Description

### \* Description

LTE430WQ-F0C is a TMR(Transmissive with Micro Reflective) type color active matrix TFT (Thin Film Transistor) liquid crystal display (LCD) that uses amorphous silicon TFT as a switching devices. This model is composed of a TFT-LCD module, a driver circuit and a back-light unit and a Touch Screen Panel(TSP).

The resolution of a 4.3" contains 480x272xRGB dots and can display up to 16.7M colors.

### \* Features

- Transmissive with Micro Reflective type and back-light with 10 LEDs are available.
- Visible in outdoor & back-light off condition with reflectivity.
- Using the Touch Screen Panel (Film to Film-Glass type).
- VA(Normally black) mode.
- 24bit RGB Interface
- DE(Data Enable) & SYNC mode - DE, Vsync, Hsync, DOTCLK

### \* Applications

- Display terminals for PMP(Portable Multimedia Player) , Potable CNS(P-CNS) application products.
- Display terminals for AV application products

\* **General information**

| Items             | Specification                        | Unit   | Note   |
|-------------------|--------------------------------------|--------|--------|
| Display area      | 95.04(H) x 53.856(V) (4.3" diagonal) | mm     | -      |
| Driver element    | a-Si TFT active matrix               | -      | -      |
| Display colors    | 16,777,216                           | colors | -      |
| Number of pixels  | 480 x 272 x RGB                      | dot    | -      |
| Pixel arrangement | RGB stripe                           | -      | -      |
| Pixel pitch       | 0.198(H) x 0.198(V)                  | mm     | 128ppi |
| Display mode      | Normally black                       | -      | -      |

\* **Mechanical information**

| Item        |               | Min.  | Typ.  | Max.  | Unit | Note |
|-------------|---------------|-------|-------|-------|------|------|
| Module size | Horizontal(H) | 105.3 | 105.5 | 105.7 | mm   | -    |
|             | Vertical(V)   | 67.0  | 67.2  | 67.4  | mm   | (1)  |
|             | Depth(D)      | 3.85  | 4.05  | 4.25  | mm   | (1)  |
| Weight      |               | -     | 60    | -     | g    | (2)  |

Note (1) Not include FPC.

Refer to the Outline Dimension in the "9. Outline Dimension" for further information.

(2) Touch Screen Panel and Back-light unit are included.

## 1. Absolute Maximum Ratings

### 1.1 Absolute Ratings Of Environment

| ITEM                  | MIN  | MAX | REMARK     |
|-----------------------|------|-----|------------|
| Storage Temperature   | -40℃ | 85℃ | Note(1)    |
| Operating Temperature | -20℃ | 70℃ | Note(2)(3) |

Note(1) 90%RH maximum humidity, 60℃ maximum wet-bulb temperature

- (2) When operated at a temperature lower than 0℃, the LCD worked slowly and the screen appeared low-contrast images due to the characteristics of LC(Liquid Crystal).
- (3) If any fixed pattern is displayed on LCD for minutes, image-sticking phenomenon may occur.

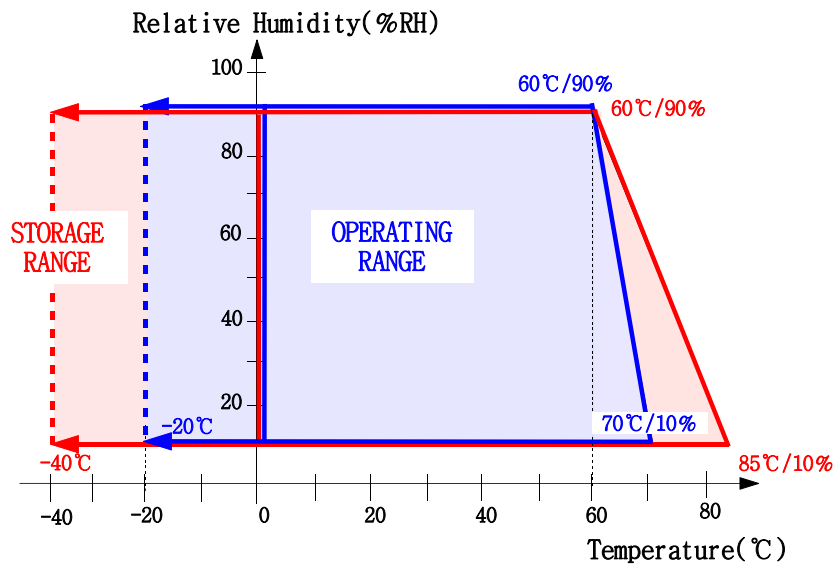

Temperature & Humidity Graph at Absolute Environment

**1.2 Electrical Absolute Ratings**

## (1) TFT-LCD Module

(Ta = 25 ± 2°C, VSS=GND=0)

| Item                 | Symbol | Min. | Max. | Unit | Note |
|----------------------|--------|------|------|------|------|
| Digital power supply | VDD    | -0.3 | 4.6  | V    | -    |

## (2) Back-Light Unit

(Ta = 25 ± 2°C)

| Item    | Symbol         | Min. | Max. | Unit. | Note |
|---------|----------------|------|------|-------|------|
| Current | I <sub>B</sub> | -    | 25   | mA    | (1)  |

Note (1) Permanent damage to the device may occur if maximum values are exceeded or reverse voltage is loaded.

Functional operation should be restricted to the conditions described under normal operating conditions.

## 2. Optical Characteristics

The following items are measured under stable conditions. The optical characteristics should be measured in a dark room or equivalent state with the methods shown in Note (1).

Measuring equipment : SR-3, BM-7, EZ-Contrast

( $T_a = 25 \pm 2^\circ\text{C}$ ,  $V_{DD}=2.5\text{V}$  or  $3.3\text{V}$ ,  $f_v = 60\text{Hz}$ ,  $f_{DCLK}=9.2\text{MHz}$ ,  $I_L = 22\text{mA}$ )

| Item                                 |         | Symbol     | Condition  | Min. | Typ. | Max. | Unit              | Note               |
|--------------------------------------|---------|------------|--|------|------|------|-------------------|--------------------|
| Contrast ratio<br>(Center point)     |         | C/R        | NOTE (1)   | 400  | 800  | -    | -                 | (2)<br>SR-3        |
| Luminance of white<br>(Center point) |         | $Y_L$      |  | 300  | 400  | -    | cd/m <sup>2</sup> | (3)<br>SR-3        |
| Color Gamut<br>(Center point)        |         | -          |  | 40   | 50   | -    | %                 |                    |
| Response<br>time                     | Rising  | $T_R$      | $\Theta = 0$<br>$\Phi = 0$<br>Normal<br>Viewing<br>Angle | -    | 17   | 22   | msec              | (4)<br>BM-7        |
|                                      | Falling | $T_F$      |  | -    | 15   | 20   |                   |                    |
| Color<br>chromaticity<br>(CIE 1931)  | White   | $W_X$      | B/L On   | 0.27 | 0.32 | 0.37 | -                 | (5)<br>SR-3        |
|                                      |         | $W_Y$      |  | 0.29 | 0.34 | 0.39 |                   |                    |
|                                      | Red     | $R_X$      |  | 0.55 | 0.60 | 0.65 |                   |                    |
|                                      |         | $R_Y$      |  | 0.31 | 0.36 | 0.41 |                   |                    |
|                                      | Green   | $G_X$      |  | 0.32 | 0.37 | 0.42 |                   |                    |
|                                      |         | $G_Y$      |  | 0.52 | 0.57 | 0.62 |                   |                    |
|                                      | Blue    | $B_X$      |  | 0.10 | 0.15 | 0.20 |                   |                    |
|                                      |         | $B_Y$      |  | 0.07 | 0.12 | 0.17 |                   |                    |
| Viewing<br>angle                     | Hor.    | $\Theta_L$ | C/R $\geq 10$<br>B/L On                                  | 70   | 80   | -    | Degrees           | (6)<br>EZ-Contrast |
|                                      |         | $\Theta_R$ |  | 70   | 80   | -    |                   |                    |
|                                      | Ver.    | $\Phi_H$   |  | 70   | 80   | -    |                   |                    |
|                                      |         | $\Phi_L$   |  | 70   | 80   | -    |                   |                    |

## Note (1) Test Equipment Setup

After stabilizing and leaving the panel alone at a given temperature for 30 min , the measurement should be executed. Measurement should be executed in a stable, windless, and dark room. 30 min after lighting the back-light. This should be measured in the center of screen.

Environment condition :  $T_a = 25 \pm 2 \text{ }^\circ\text{C}$

Back-Light On condition

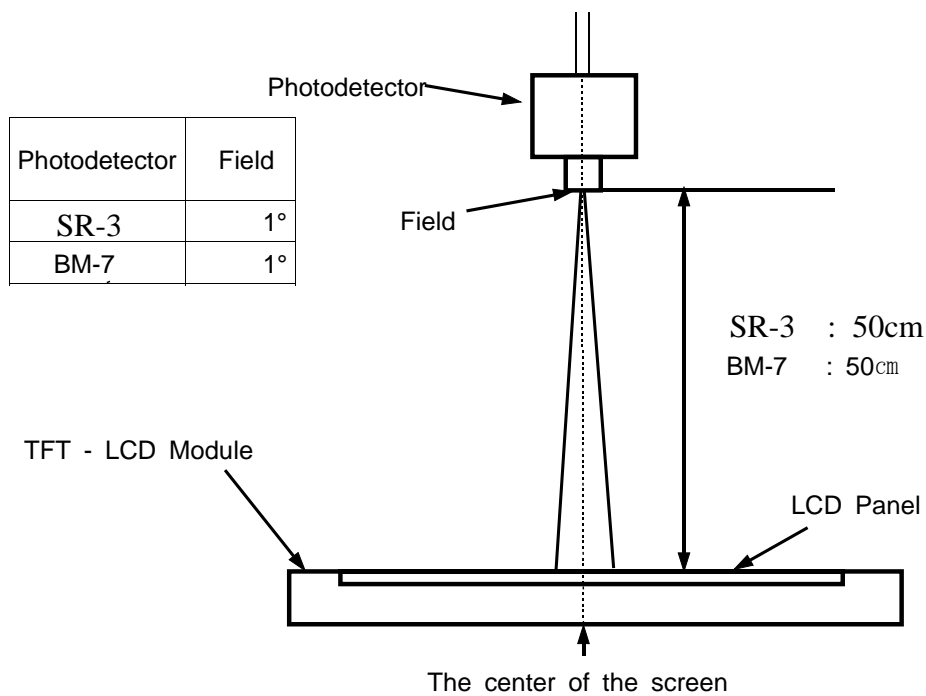

Note (2) Definition of Contrast Ratio (C/R) : Ratio of gray max (Gmax) & gray min (Gmin) at the center point

$$CR = \frac{G \text{ max}}{G \text{ min}} \quad \begin{array}{l} * G_{\text{max}} : \text{Luminance with all pixels white} \\ * G_{\text{min}} : \text{Luminance with all pixels black} \end{array}$$

Note (3) Definition of Luminance of White (Y<sub>L</sub>) : Luminance of white at the center point

Definition of Brightness Uniformity (B<sub>uni</sub>)

$$B_{uni} = \left( \frac{B_{\text{min}}}{B_{\text{max}}} \right) \times 100$$

where, B<sub>max</sub> = Maximum Brightness

B<sub>min</sub> = Minimum Brightness

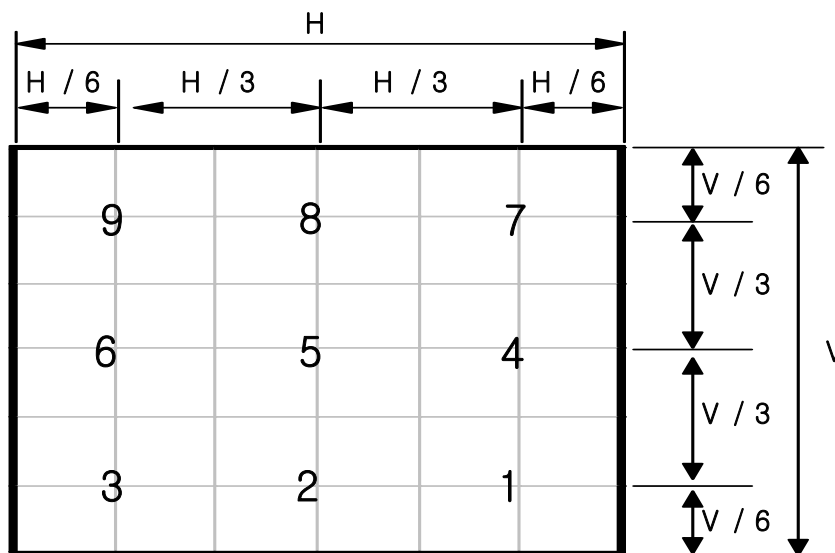

The spot locations for luminance measurement

Note (4) Definition of Response time : Sum of Tr ,Tf

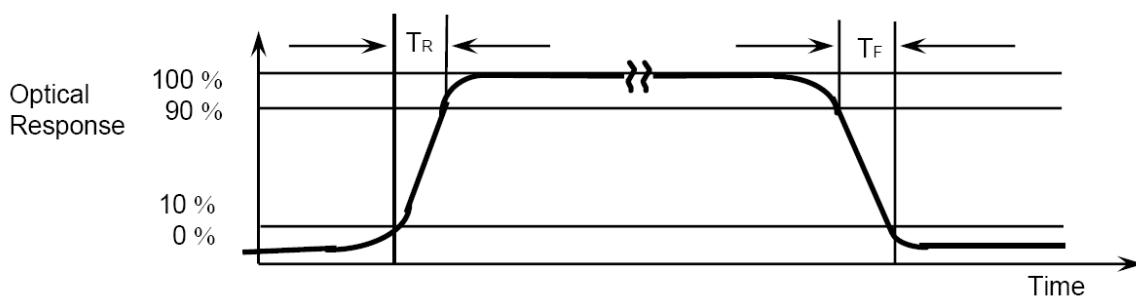
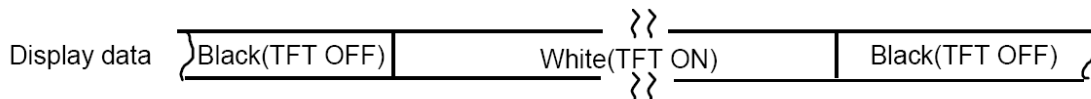

Note (5) Definition of Color Chromaticity (CIE 1931)

Color coordinate of white & red, green, blue at center point.

Note (6) Definition of Viewing Angle : Viewing angle range ( $CR \geq 10$  )

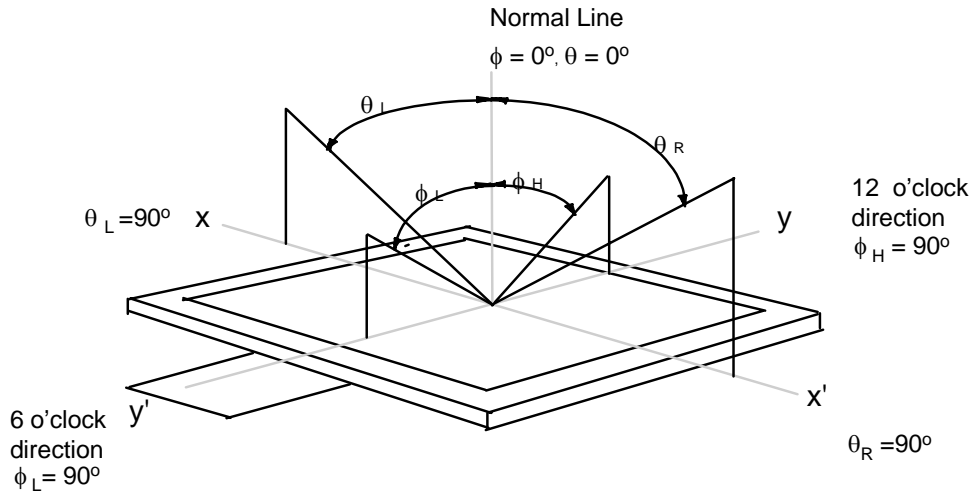

### 3. Electrical Characteristics

#### 3.1 TFT-LCD Module

Ta = 25 ± 2°C

| ITEM                       | Symbol            | Min.    | Typ.  | Max.    | Unit | Note     |
|----------------------------|-------------------|---------|-------|---------|------|----------|
| Digital power supply       | VDD               | 2.25    | 2.5   | 2.9     | V    | (1)      |
|                            |                   | 2.9     | 3.3   | 3.5     | V    | (2)      |
| Input "High" level voltage | VIH               | 0.7*VDD | -     | VDD     | V    |          |
| Input "Low" level voltage  | VIL               | 0       | -     | 0.3*VDD | V    |          |
| Vsync Frequency            | f <sub>v</sub>    | -       | 60    | 70      | Hz   |          |
| Hsync Frequency            | f <sub>H</sub>    | -       | 17.28 | -       | kHz  |          |
| Main Frequency             | f <sub>DCLK</sub> | -       | 9.2   | 15.0    | MHZ  |          |
| Power Dissipation          | White             | -       | 100   | 120     | mW   | (3), (4) |
|                            | Black             |         | 85    | 105     | mW   |          |

Note (1). PWRSEL = Low

Note (2). PWRSEL = High

※ Refer to the "6. Input Terminal Pin Assignment"

Note (3). f<sub>v</sub>=60Hz, f<sub>DCLK</sub>=9.2MHZ, VDD=2.5V or 3.3V

Note (4). Power Dissipation check pattern

a) White Pattern

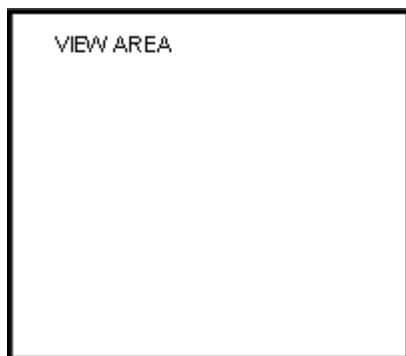

b) Black Pattern

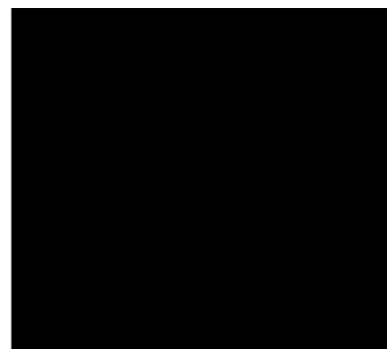

### 3.2 Back-Light unit

The back-light system is an edge-lighting type with 10 white LED(Light Emitting Diode)s.

( $T_a=25 \pm 2^\circ\text{C}$ )

| Item              | Symbol   | Min. | Typ. | Max. | Unit | Note   |
|-------------------|----------|------|------|------|------|--------|
| LEDs Current      | $I_B$    | -    | 22   | 23   | mA   | (1)(3) |
| Power Consumption | $P_{BL}$ | -    | 730  | -    | mW   | (2)(3) |

Note (1) 10 LEDs serial type.

(2) Where  $I_B = 22 \text{ mA}$ ,  $V_B = P_{BL} / I_B$

(3) DC current(voltage) use only.

If PWM(pulse width modulation) used, some problems may be happened.

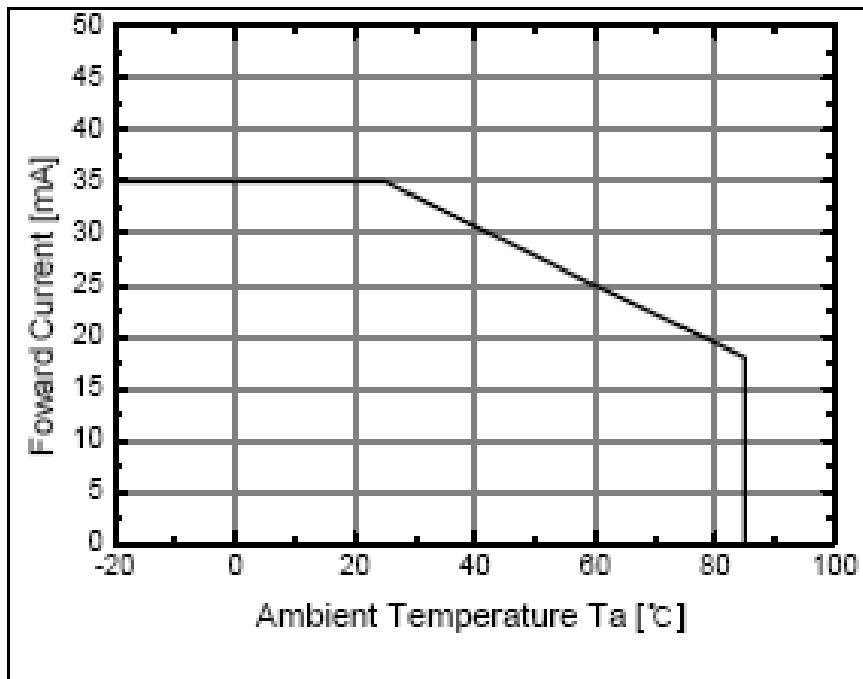

## 4. Touch Screen Panel Specifications

### 4-1. Electrical Characteristics

| Item                  | Min. | Typ. | Max. | Unit       | Note                          |
|-----------------------|------|------|------|------------|-------------------------------|
| Linearity             | -1.5 | -    | 1.5  | %          | Analog X and Y directions     |
| Terminal resistance   | 100  | -    | 900  | $\Omega$   | X                             |
|                       | 100  | -    | 900  | $\Omega$   | Y                             |
| Insulation resistance | 10   | -    | -    | M $\Omega$ | DC 25V                        |
| Voltage               | -    | -    | 7    | V          | DC                            |
| Chattering            | -    | -    | 10   | ms         | 100k $\Omega$ pull-up         |
| Transparency          | -    | 80   | -    | %          | JIS-K7105, ASTM D1003, @550nm |

Caution (1) : Do not operate it with a thing except a polyacetal pen(tip R0.8mm or more) or a finger, especially those with hard or sharp tips such as a ball point pen or a mechanical pencil.

### 4-2. Mechanical & Reliability Characteristics

| Item                               | Min.             | Typ. | Max. | Unit       | Note                  |
|------------------------------------|------------------|------|------|------------|-----------------------|
| Activation force                   | -                |      | 80   | g          | (1)                   |
| Durability<br>(surface scratching) | Write<br>100,000 | -    | -    | characters | (2)                   |
| Durability<br>(surface pitting)    | 1,000,000        | -    | -    | touches    | (3)                   |
| Surface hardness                   | 3                | -    | -    | H          | JIS K5400, ASTM D3363 |

Note (1) Stylus pen Input : R0.8mm polyacetal pen or Finger

(2) Measurement for Surface area

- Scratch 100,000 times straight line on the Film with a stylus change every 20,000times
- Force : 250gf
- Speed : 60mm/sec
- Stylus : R0.8 polyacetal tip

(3) Pit 1,000,000 times on the Film with a R8.0 silicon rubber.

- Force : 250gf
- Speed : 2times/sec

4-3. Design Guide

- Avoid the design that Front-case overlap and press on the active area of the touch-panel.
- Give enough gap (over 0.5mm at compressed) between the front case and touch-panel to protect wrong operating.

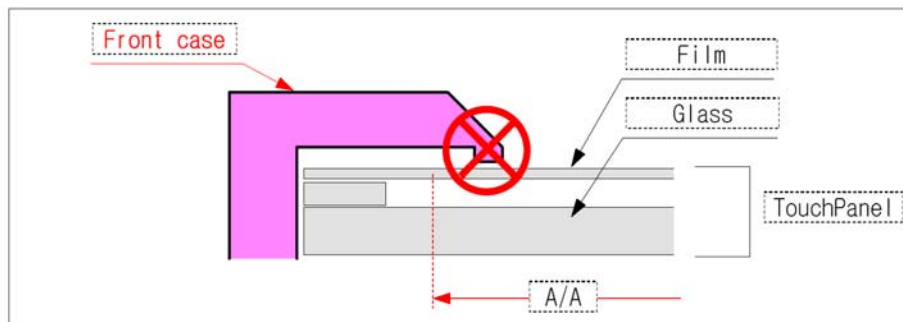

- Use a buffer material(Gasket) between the touch-panel and Front-case to protect damage and wrong operating.
- Avoid the design that buffer material overlap and press on the inside of touch-panel viewing area.

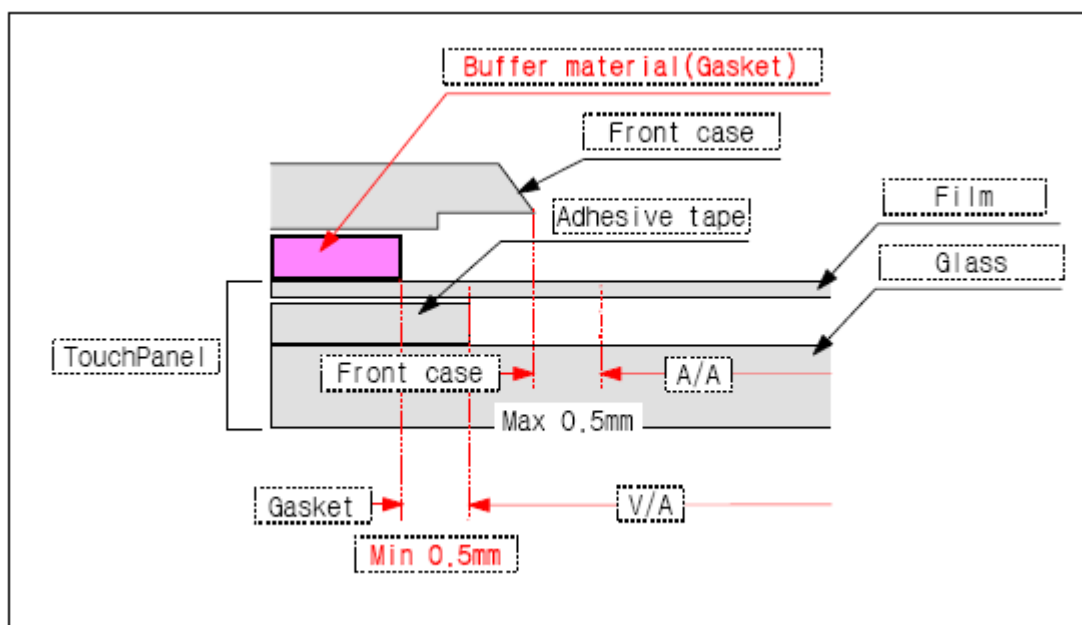

- Consider to LCD integration and tolerance when designing Front Case and Gasket refer to counter drawing.

# TSP Design Guide

Left side

Right side

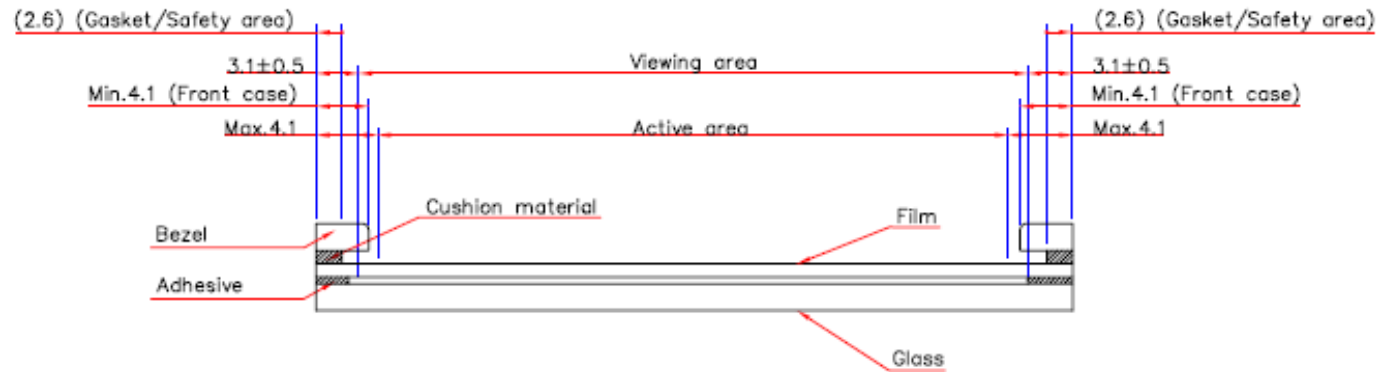

Bottom side

Top side

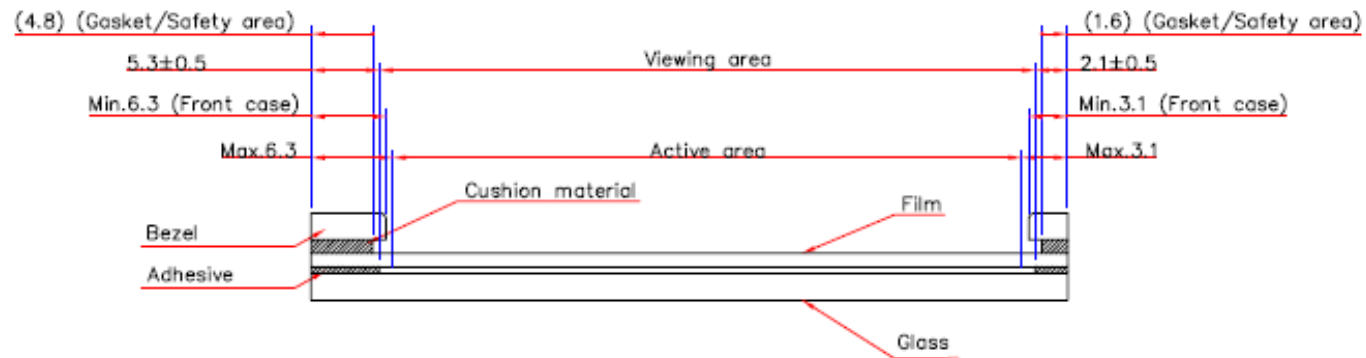

## 5. Block Diagram

### 5.1 TFT-LCD Module (Interface System Structure) with Back Light Unit

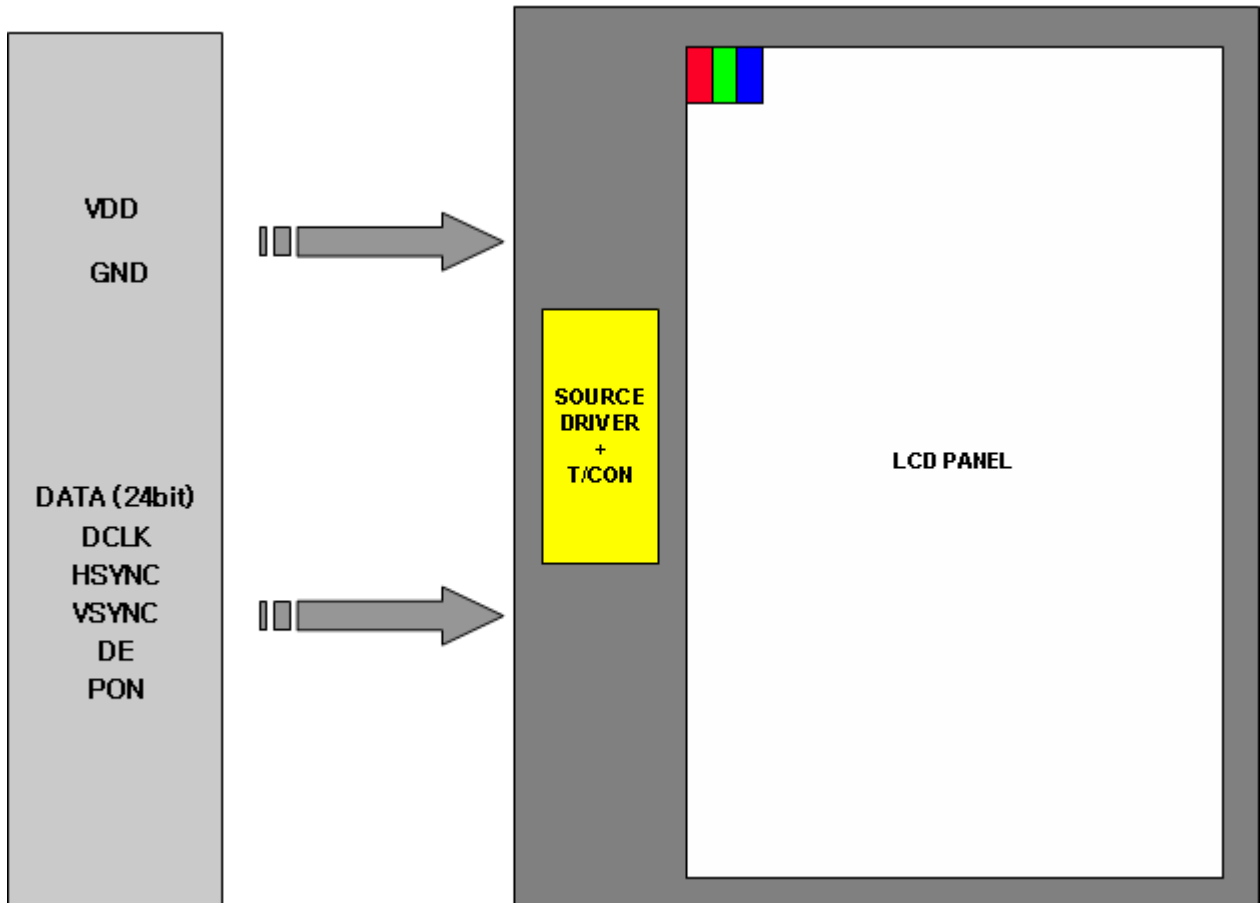

5.2 Touch Screen Panel

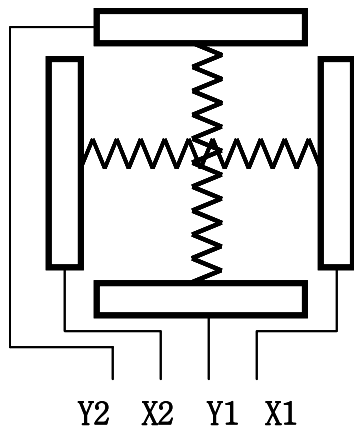

Top View

X : Upper electrode  
Y : Lower electrode

5.3 Back-light Unit (Connector : 2 pin FPC Solder type)

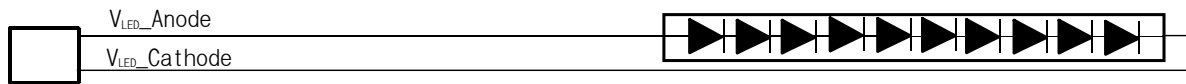

## 6. Input Terminal Pin Assignment

### 6.1 Input Signal & Power (Connector type : 45Pin / 0.5mm pitch / Top contact)

- Hirose : FH12 series

| Pin# | Symbol | Function                    | Remark | Pin# | Symbol | Function               | Remark                |
|------|--------|-----------------------------|--------|------|--------|------------------------|-----------------------|
| 1    | VSS    | Ground                      |        | 26   | B5     | Blue Data              |                       |
| 2    | VSS    | Ground                      |        | 27   | B6     | Blue Data              |                       |
| 3    | VDD    | Power Supply<br>(2.5or3.3V) |        | 28   | B7     | Blue Data              | (MSB)                 |
| 4    | VDD    | Power Supply<br>(2.5or3.3V) |        | 29   | VSS    | Ground                 |                       |
| 5    | R0     | Red Data                    | (LSB)  | 30   | PCLK   | Pixel Clock            |                       |
| 6    | R1     | Red Data                    |        | 31   | PON    | Display on/off         |                       |
| 7    | R2     | Red Data                    |        | 32   | HSYNC  | Horizontal Sync Signal |                       |
| 8    | R3     | Red Data                    |        | 33   | VSYNC  | Vertical Sync Signal   |                       |
| 9    | R4     | Red Data                    |        | 34   | DE     | Data Enable            |                       |
| 10   | R5     | Red Data                    |        | 35   | PWRSEL | VDD power select       | High:3.3V<br>Low:2.5V |
| 11   | R6     | Red Data                    |        | 36   | VSS    | Ground                 |                       |
| 12   | R7     | Red Data                    | (MSB)  | 37   | Y2     | Y_Up                   |                       |
| 13   | G0     | Green Data                  | (LSB)  | 38   | X2     | X_Left                 |                       |
| 14   | G1     | Green Data                  |        | 39   | Y1     | Y_Bottom               |                       |
| 15   | G2     | Green Data                  |        | 40   | X1     | X_Right                |                       |
| 16   | G3     | Green Data                  |        | 41   | VSS    | Ground                 |                       |
| 17   | G4     | Green Data                  |        | 42   | VLED1- | LED 1 Cathode          |                       |
| 18   | G5     | Green Data                  |        | 43   | VLED1+ | LED 1 Anode            |                       |
| 19   | G6     | Green Data                  |        | 44   | NC     | Non Connect            |                       |
| 20   | G7     | Green Data                  | (MSB)  | 45   | NC     | Non Connect            |                       |
| 21   | B0     | Blue Data                   | (LSB)  |      |        |                        |                       |
| 22   | B1     | Blue Data                   |        |      |        |                        |                       |
| 23   | B2     | Blue Data                   |        |      |        |                        |                       |
| 24   | B3     | Blue Data                   |        |      |        |                        |                       |
| 25   | B4     | Blue Data                   |        |      |        |                        |                       |

### 6.2 Touch Screen Panel (Connector : 4Pin FPC Solder type)

| Pin No. | Symbol | I/O    | Function                               |
|---------|--------|--------|--|
| 1       | X1     | Right  | Right electrode - differential analog  |
| 2       | Y1     | Bottom | Bottom electrode - differential analog |
| 3       | X2     | Left   | Left electrode - differential analog   |
| 4       | Y2     | Top    | Top electrode - differential analog    |

### 6.3 Input Signal, Basic Display Colors and Gray Scale of Each Colors

| COLOR               | DISPLAY | DATA SIGNAL |    |    |    |    |    |    |       |    |    |    |    |    |    |      |    |    |    |    |    | GRAY SCALE LEVEL |    |    |    |         |
|---------------------|---------|-------------|----|----|----|----|----|----|-------|----|----|----|----|----|----|------|----|----|----|----|----|------------------|----|----|----|---------|
|                     |         | RED         |    |    |    |    |    |    | GREEN |    |    |    |    |    |    | BLUE |    |    |    |    |    |                  |    |    |    |         |
|                     |         | R0          | R1 | R2 | R3 | R4 | R5 | R6 | R7    | G0 | G1 | G2 | G3 | G4 | G5 | G6   | G7 | B0 | B1 | B2 | B3 |                  | B4 | B5 | B6 | B7      |
| BASIC COLOR         | BLACK   | 0           | 0  | 0  | 0  | 0  | 0  | 0  | 0     | 0  | 0  | 0  | 0  | 0  | 0  | 0    | 0  | 0  | 0  | 0  | 0  | 0                | 0  | 0  | 0  | -       |
|                     | BLUE    | 0           | 0  | 0  | 0  | 0  | 0  | 0  | 0     | 0  | 0  | 0  | 0  | 0  | 0  | 0    | 0  | 1  | 1  | 1  | 1  | 1                | 1  | 1  | 1  | -       |
|                     | GREEN   | 0           | 0  | 0  | 0  | 0  | 0  | 0  | 0     | 1  | 1  | 1  | 1  | 1  | 1  | 1    | 1  | 0  | 0  | 0  | 0  | 0                | 0  | 0  | 0  | -       |
|                     | CYAN    | 0           | 0  | 0  | 0  | 0  | 0  | 0  | 0     | 1  | 1  | 1  | 1  | 1  | 1  | 1    | 1  | 1  | 1  | 1  | 1  | 1                | 1  | 1  | 1  | -       |
|                     | RED     | 1           | 1  | 1  | 1  | 1  | 1  | 1  | 1     | 0  | 0  | 0  | 0  | 0  | 0  | 0    | 0  | 0  | 0  | 0  | 0  | 0                | 0  | 0  | 0  | -       |
|                     | MAGENTA | 1           | 1  | 1  | 1  | 1  | 1  | 1  | 1     | 0  | 0  | 0  | 0  | 0  | 0  | 0    | 0  | 1  | 1  | 1  | 1  | 1                | 1  | 1  | 1  | -       |
|                     | YELLOW  | 1           | 1  | 1  | 1  | 1  | 1  | 1  | 1     | 1  | 1  | 1  | 1  | 1  | 1  | 1    | 1  | 0  | 0  | 0  | 0  | 0                | 0  | 0  | 0  | -       |
|                     | WHITE   | 1           | 1  | 1  | 1  | 1  | 1  | 1  | 1     | 1  | 1  | 1  | 1  | 1  | 1  | 1    | 1  | 1  | 1  | 1  | 1  | 1                | 1  | 1  | 1  | -       |
| GRAY SCALE OF RED   | BLACK   | 0           | 0  | 0  | 0  | 0  | 0  | 0  | 0     | 0  | 0  | 0  | 0  | 0  | 0  | 0    | 0  | 0  | 0  | 0  | 0  | 0                | 0  | 0  | 0  | R0      |
|                     | DARK ↑  | 1           | 0  | 0  | 0  | 0  | 0  | 0  | 0     | 0  | 0  | 0  | 0  | 0  | 0  | 0    | 0  | 0  | 0  | 0  | 0  | 0                | 0  | 0  | 0  | R1      |
|                     |         | 0           | 1  | 0  | 0  | 0  | 0  | 0  | 0     | 0  | 0  | 0  | 0  | 0  | 0  | 0    | 0  | 0  | 0  | 0  | 0  | 0                | 0  | 0  | 0  | R2      |
|                     |         | :           | :  | :  | :  | :  | :  | :  | :     | :  | :  | :  | :  | :  | :  | :    | :  | :  | :  | :  | :  | :                | :  | :  | :  | R3~R252 |
|                     |         | :           | :  | :  | :  | :  | :  | :  | :     | :  | :  | :  | :  | :  | :  | :    | :  | :  | :  | :  | :  | :                | :  | :  | :  |         |
|                     | LIGHT ↓ | 1           | 0  | 1  | 1  | 1  | 1  | 1  | 1     | 0  | 0  | 0  | 0  | 0  | 0  | 0    | 0  | 0  | 0  | 0  | 0  | 0                | 0  | 0  | 0  | R253    |
|                     |         | 0           | 1  | 1  | 1  | 1  | 1  | 1  | 1     | 0  | 0  | 0  | 0  | 0  | 0  | 0    | 0  | 0  | 0  | 0  | 0  | 0                | 0  | 0  | 0  | R254    |
|                     | RED     | 1           | 1  | 1  | 1  | 1  | 1  | 1  | 1     | 0  | 0  | 0  | 0  | 0  | 0  | 0    | 0  | 0  | 0  | 0  | 0  | 0                | 0  | 0  | 0  | R255    |
| GRAY SCALE OF GREEN | BLACK   | 0           | 0  | 0  | 0  | 0  | 0  | 0  | 0     | 0  | 0  | 0  | 0  | 0  | 0  | 0    | 0  | 0  | 0  | 0  | 0  | 0                | 0  | 0  | 0  | G0      |
|                     | DARK ↑  | 0           | 0  | 0  | 0  | 0  | 0  | 0  | 0     | 1  | 0  | 0  | 0  | 0  | 0  | 0    | 0  | 0  | 0  | 0  | 0  | 0                | 0  | 0  | 0  | G1      |
|                     |         | 0           | 0  | 0  | 0  | 0  | 0  | 0  | 0     | 0  | 1  | 0  | 0  | 0  | 0  | 0    | 0  | 0  | 0  | 0  | 0  | 0                | 0  | 0  | 0  | G2      |
|                     |         | :           | :  | :  | :  | :  | :  | :  | :     | :  | :  | :  | :  | :  | :  | :    | :  | :  | :  | :  | :  | :                | :  | :  | :  | G3~G252 |
|                     |         | :           | :  | :  | :  | :  | :  | :  | :     | :  | :  | :  | :  | :  | :  | :    | :  | :  | :  | :  | :  | :                | :  | :  | :  |         |
|                     | LIGHT ↓ | 0           | 0  | 0  | 0  | 0  | 0  | 0  | 0     | 1  | 0  | 1  | 1  | 1  | 1  | 1    | 1  | 0  | 0  | 0  | 0  | 0                | 0  | 0  | 0  | G253    |
|                     |         | 0           | 0  | 0  | 0  | 0  | 0  | 0  | 0     | 0  | 1  | 1  | 1  | 1  | 1  | 1    | 1  | 0  | 0  | 0  | 0  | 0                | 0  | 0  | 0  | G254    |
|                     | GREEN   | 0           | 0  | 0  | 0  | 0  | 0  | 0  | 0     | 1  | 1  | 1  | 1  | 1  | 1  | 1    | 1  | 0  | 0  | 0  | 0  | 0                | 0  | 0  | 0  | G255    |
| GRAY SCALE OF BLUE  | BLACK   | 0           | 0  | 0  | 0  | 0  | 0  | 0  | 0     | 0  | 0  | 0  | 0  | 0  | 0  | 0    | 0  | 0  | 0  | 0  | 0  | 0                | 0  | 0  | 0  | B0      |
|                     | DARK ↑  | 0           | 0  | 0  | 0  | 0  | 0  | 0  | 0     | 0  | 0  | 0  | 0  | 0  | 0  | 0    | 0  | 1  | 0  | 0  | 0  | 0                | 0  | 0  | 0  | B1      |
|                     |         | 0           | 0  | 0  | 0  | 0  | 0  | 0  | 0     | 0  | 0  | 0  | 0  | 0  | 0  | 0    | 0  | 0  | 1  | 0  | 0  | 0                | 0  | 0  | 0  | B2      |
|                     |         | :           | :  | :  | :  | :  | :  | :  | :     | :  | :  | :  | :  | :  | :  | :    | :  | :  | :  | :  | :  | :                | :  | :  | :  | B3~B252 |
|                     |         | :           | :  | :  | :  | :  | :  | :  | :     | :  | :  | :  | :  | :  | :  | :    | :  | :  | :  | :  | :  | :                | :  | :  | :  |         |
|                     | LIGHT ↓ | 0           | 0  | 0  | 0  | 0  | 0  | 0  | 0     | 0  | 0  | 0  | 0  | 0  | 0  | 0    | 0  | 1  | 0  | 1  | 1  | 1                | 1  | 1  | 1  | B253    |
|                     |         | 0           | 0  | 0  | 0  | 0  | 0  | 0  | 0     | 0  | 0  | 0  | 0  | 0  | 0  | 0    | 0  | 0  | 1  | 1  | 1  | 1                | 1  | 1  | 1  | B254    |
|                     | BLUE    | 0           | 0  | 0  | 0  | 0  | 0  | 0  | 0     | 0  | 0  | 0  | 0  | 0  | 0  | 0    | 0  | 1  | 1  | 1  | 1  | 1                | 1  | 1  | 1  | B255    |

Note) Definition of Gray :

Rn : Red Gray, Gn : Green Gray, Bn : Blue Gray (n = Gray level)

Input Signal : 0 = Low level voltage, 1 = High level voltage

6.4 PIXEL FORMAT

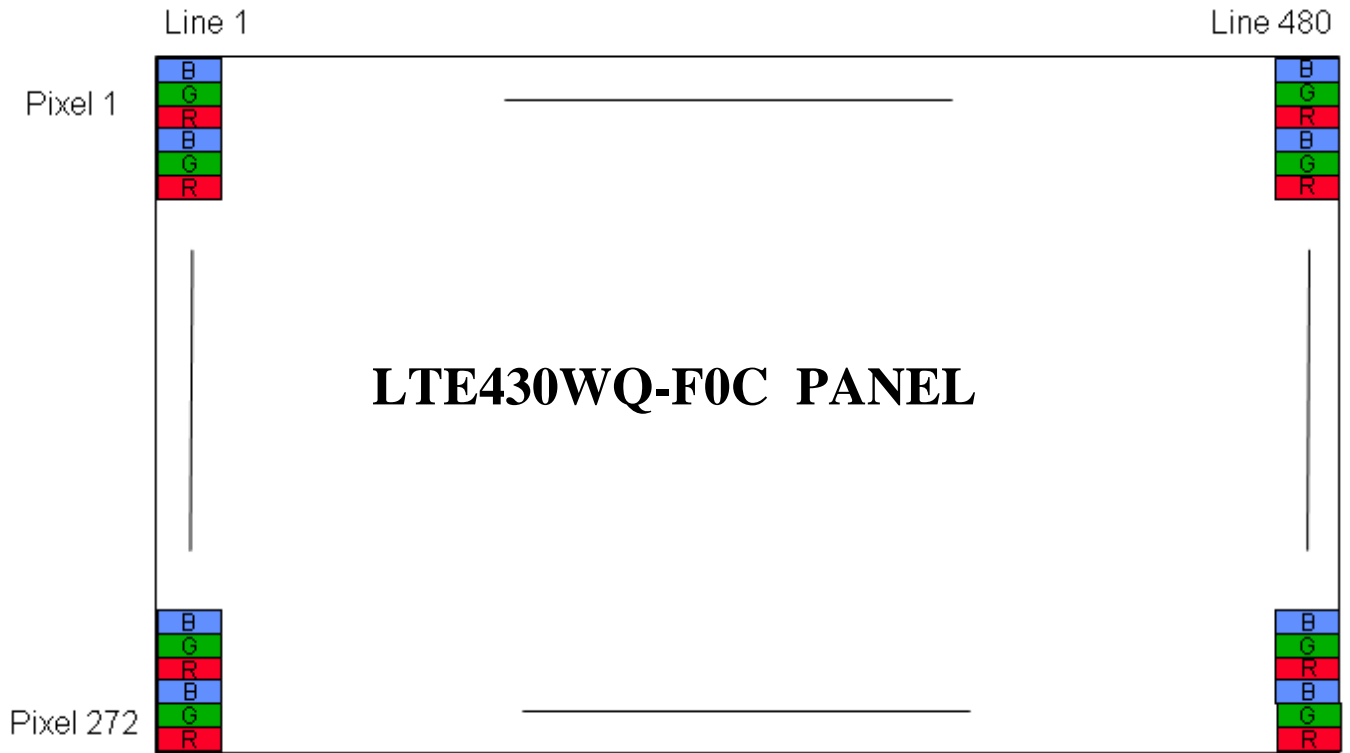

## 7. INTERFACE TIMING

### 7-1. Vertical timing

| Signal                  | Symbol | Min. | Typ. | Max. | Unit | Note |
|-------------------------|--------|------|------|------|------|------|
| Frame Frequency         | fFRM   | -    | 60   | 70   | Hz   |      |
| VSYNC(Frame) Period     | VCYC   | 248  | 288  | 335  | H    |      |
| VSYNC Low width         | VLW    | 1    | 10   | -    | H    |      |
| Vertical Display Period | VDP    |      | 272  | -    | H    |      |
| Vertical Back porch     | VBP    | -    | 12   | -    | H    |      |
| Vertical Front porch    | VFP    | 2    | 4    | -    | H    |      |

### 7-2. Horizontal timing

| Signal                    | Symbol              | Min. | Typ. | Max. | Unit   | Note       |
|---------------------------|---------------------|------|------|------|--------|------------|
| HSYNC(1H) Period          | HCYC                | 490  | 533  | 605  | DOTCLK |            |
| HSYNC Low width           | HLW                 | 4    | 41   | -    | DOTCLK |            |
| Horizontal Display Period | HDP                 | -    | 480  | -    | DOTCLK |            |
| Horizontal Back porch     | HBP                 | 8    | 45   | -    | DOTCLK |            |
| Horizontal Front porch    | HFP                 | 2    | 8    | -    | DOTCLK |            |
| DOTCLK Frequency          | f <sub>DOTCLK</sub> | -    | 9.2  | 15   | MHz    | @fFRM=60Hz |

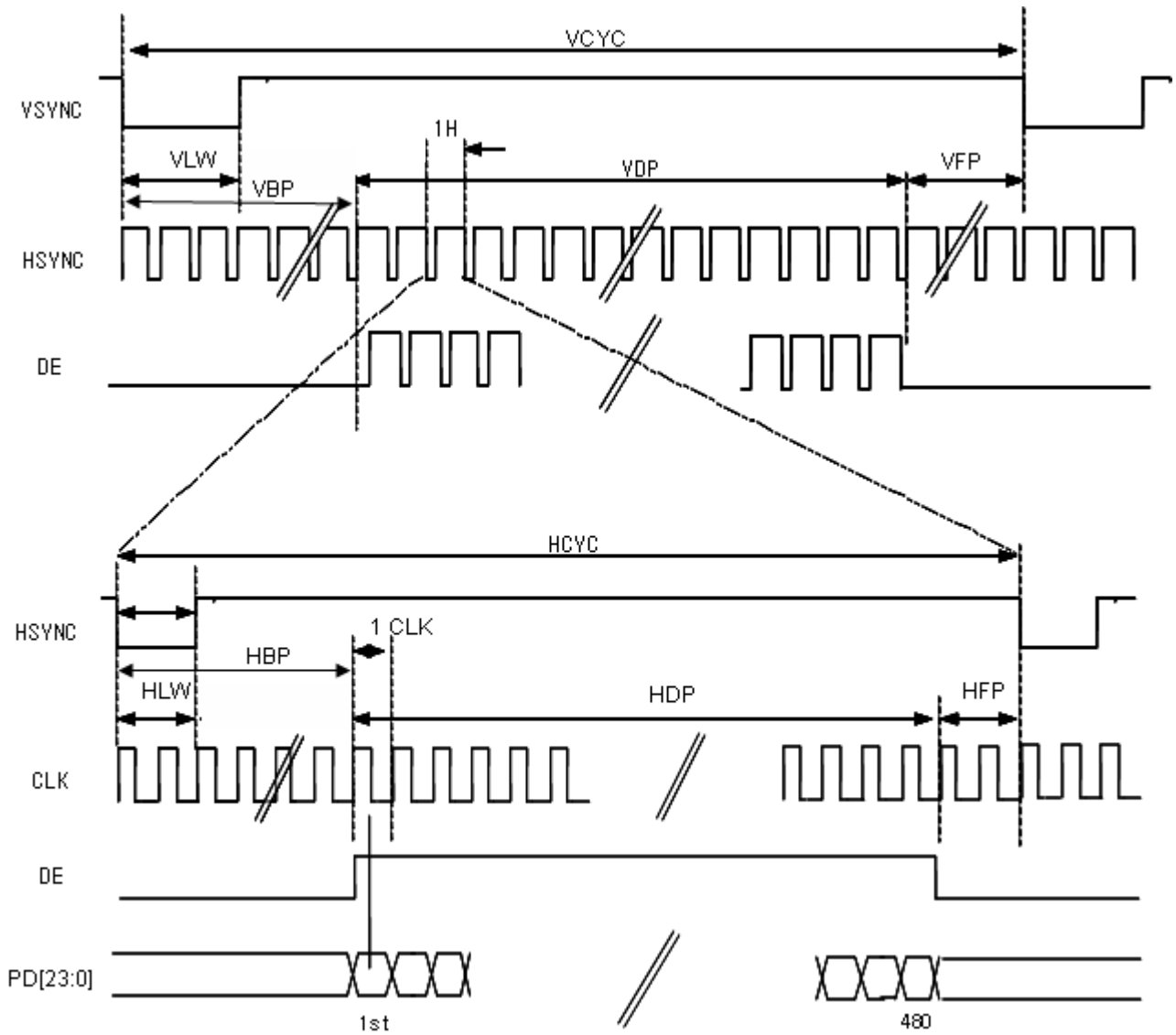

## 7-3. AC characteristics

※ Operating at VDD=2.25~2.9V , Ta = -40°C~+85°C

| Parameter                                  | Symbol                   | Min. | Typ. | Max. | Unit |
|--|--------------------------|------|------|------|------|
| VSYNC,HSYNC setup time                     | $t_{SYNCS}$              | 10   | -    | -    | ns   |
| ENABLE (DE) setup time                     | $t_{ENS}$                | 10   | -    | -    |      |
| ENABLE (DE) hold time                      | $t_{ENH}$                | 10   | -    | -    |      |
| DOTCLK "Low" level pulse width             | $P_{WDL}$                | 25   | -    | -    |      |
| DOTCLK "High" level pulse width            | $P_{WDH}$                | 25   | -    | -    |      |
| DOTCLK cycle time                          | $t_{CYCD}$               | 66.7 | -    | -    |      |
| Data setup time                            | $t_{PDS}$                | 10   | -    | -    |      |
| Data hold time                             | $t_{PDH}$                | 10   | -    | -    |      |
| DOTCLK,VSYNC,HSYNC<br>clock rise/fall time | $t_{rgrb}$<br>$t_{rgbf}$ | -    | -    | 5    |      |

※ Operating at VDD=2.9~3.5V , Ta = -40°C~+85°C

| Parameter                                  | Symbol                   | Min. | Typ. | Max. | Unit |
|--|--------------------------|------|------|------|------|
| VSYNC,HSYNC setup time                     | $t_{SYNCS}$              | 10   | -    | -    | ns   |
| ENABLE (DE) setup time                     | $t_{ENS}$                | 10   | -    | -    |      |
| ENABLE (DE) hold time                      | $t_{ENH}$                | 10   | -    | -    |      |
| DOTCLK "Low" level pulse width             | $P_{WDL}$                | 25   | -    | -    |      |
| DOTCLK "High" level pulse width            | $P_{WDH}$                | 25   | -    | -    |      |
| DOTCLK cycle time                          | $t_{CYCD}$               | 66.7 | -    | -    |      |
| Data setup time                            | $t_{PDS}$                | 10   | -    | -    |      |
| Data hold time                             | $t_{PDH}$                | 10   | -    | -    |      |
| DOTCLK,VSYNC,HSYNC<br>clock rise/fall time | $t_{rgrb}$<br>$t_{rgbf}$ | -    | -    | 5    |      |

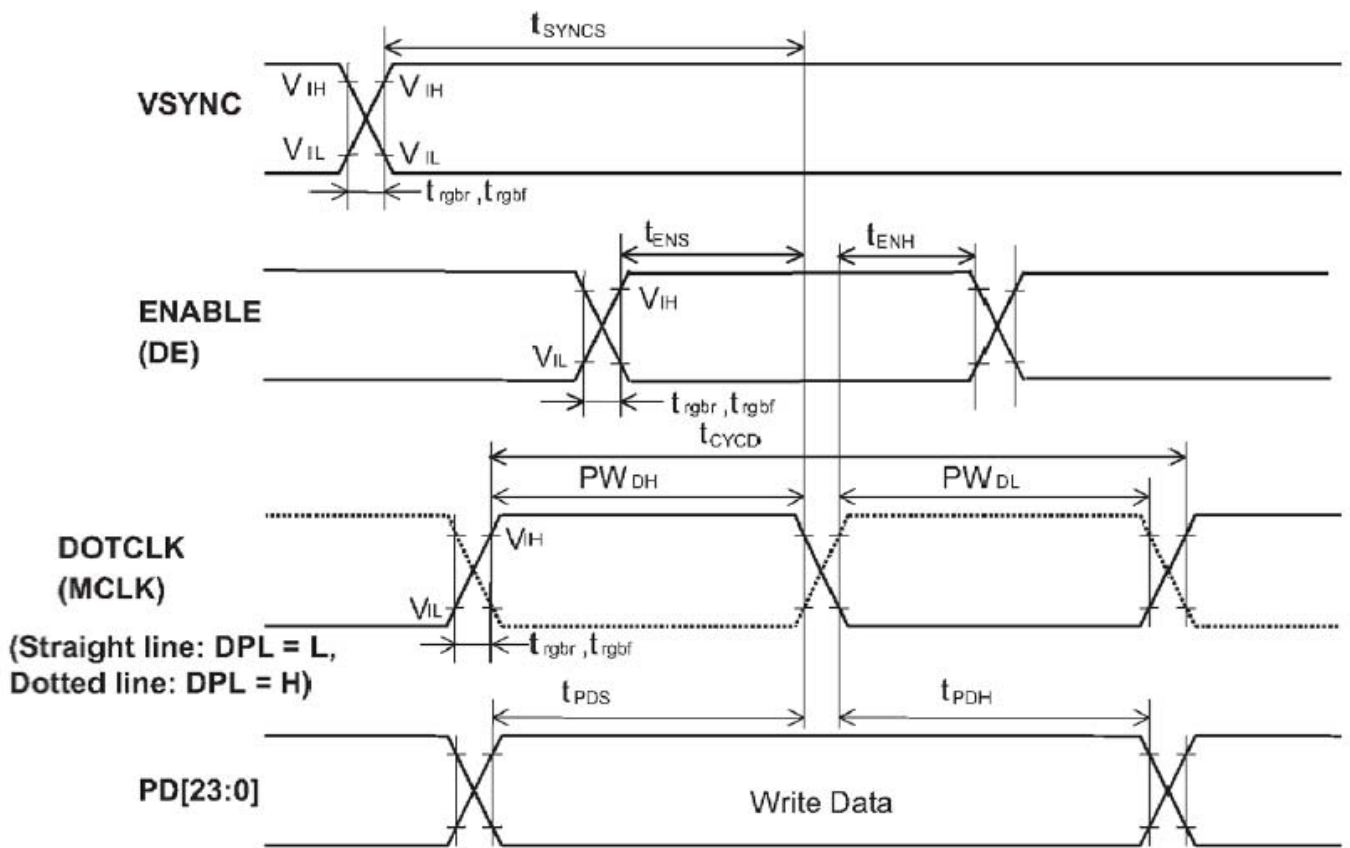

## 7-4. PON timing characteristics.

※ Operating at VDD=2.25~3.5V , Ta = -40°C~+85°C

| Item                  | Symbol            | Min. | Typ. | Max. | unit   |
|-----------------------|-------------------|------|------|------|--------|
| PON setup (SYNC mode) | $t_{PONS\bar{V}}$ | 10   | -    | -    | DOTCLK |

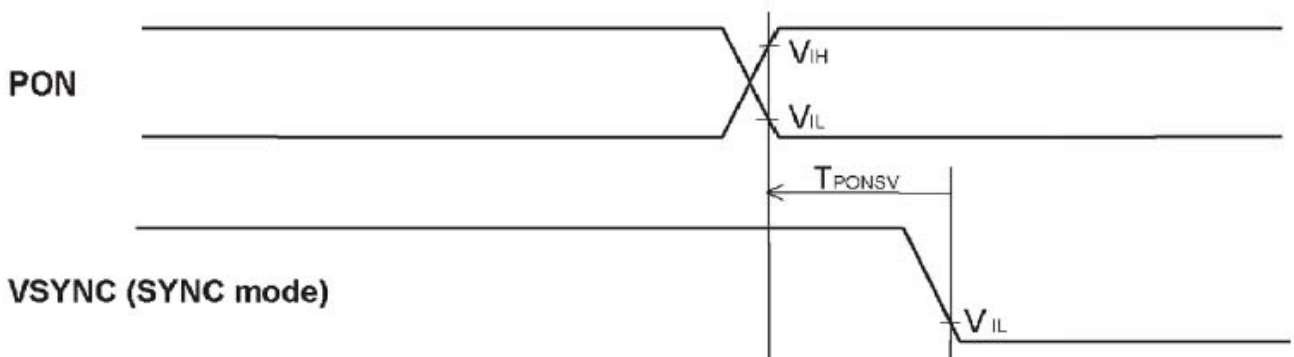

## 8. Power On/Off Sequence

- To prevent a latch-up or DC operation of the LCD module, the power on/off sequence should be as the diagram below.

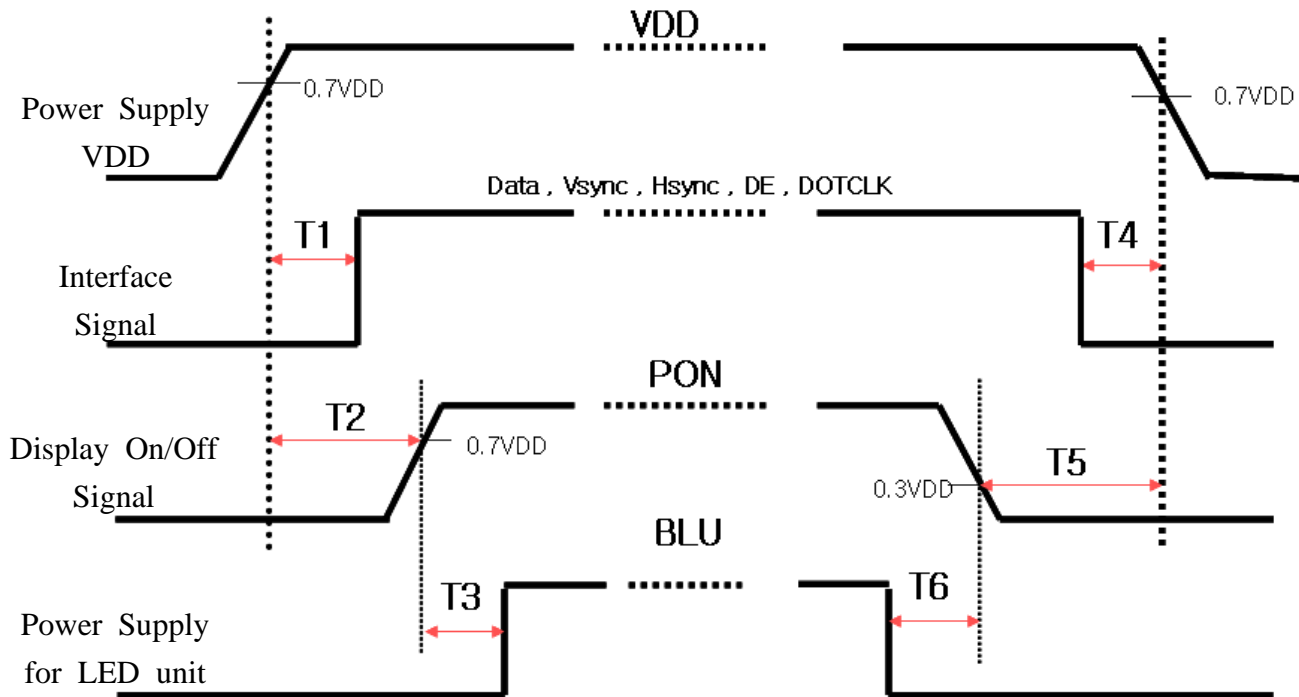

| Symbol | Specification                  | Note |
|--------|--------------------------------|------|
| T1     | $0 \text{ ms} < T1 < T2$       |      |
| T2     | $10 \text{ ms} < T2$           | (1)  |
| T3     | $10 \text{ frames} < T3$       |      |
| T4     | $10 \text{ ms} < T4 < T5$      |      |
| T5     | $(5 \text{ frames} + T4) < T5$ | (1)  |
| T6     | $10 \text{ frames} < T6$       |      |

Note(1) Refer to "7-4. PON timing characteristics."

| NO | PART NAME         | CODE NO | SPECIFICATION | Q'TY | SPEC NO | REMARK |
|----|-------------------|---------|---------------|------|---------|--------|
| 1  | OUTLINE DIMENSION | -       | LTE430WQ-FOC  | 1EA  |         |        |

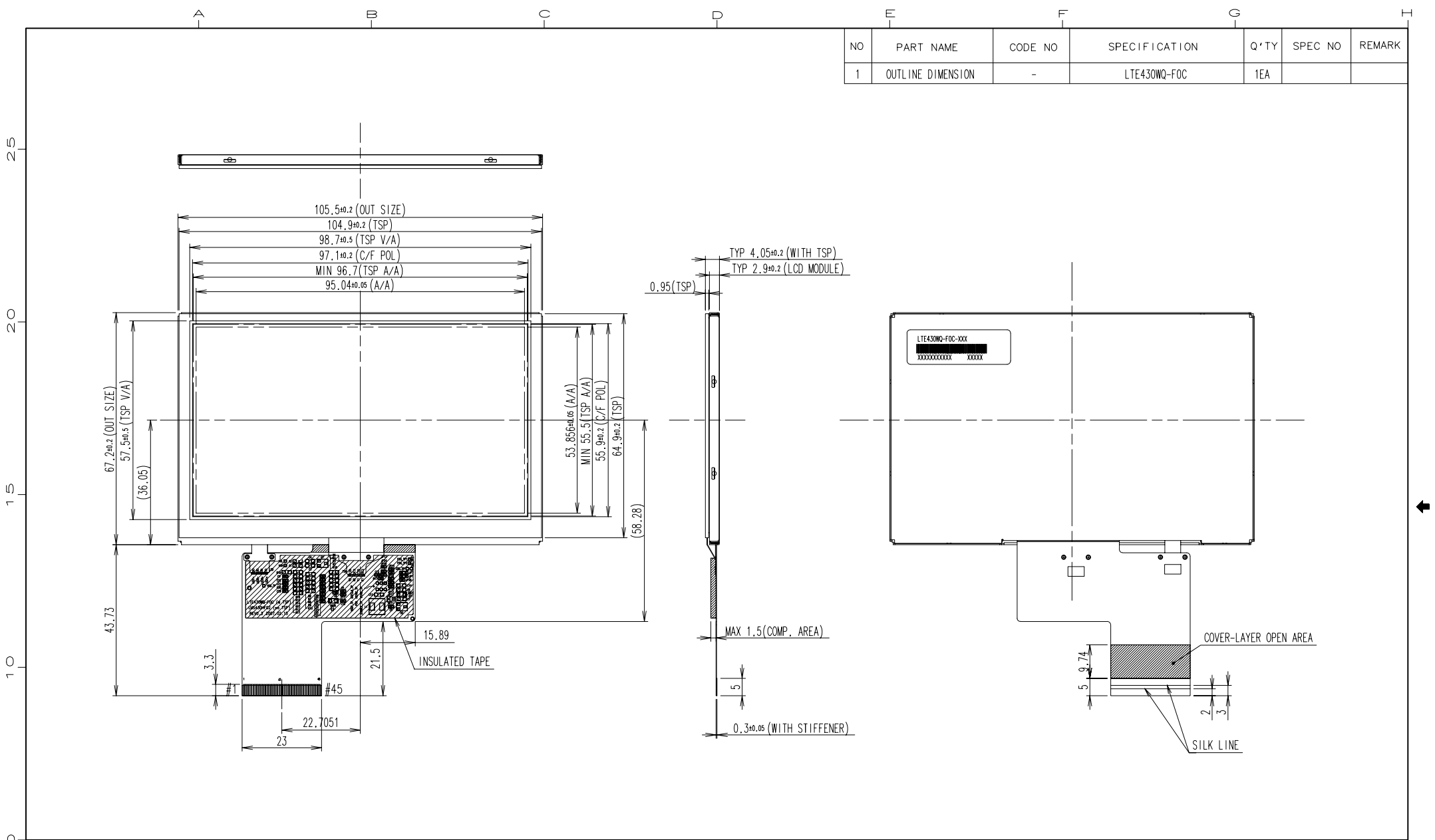

| GENERAL TOLERANCE |         |         |         |                     | REV     |           | DATE     |          |          |            | DESCRIPTION OF REVISION |                   |       |          | REASON   |      | CHG'D BY |
|-------------------|---------|---------|---------|---------------------|---------|-----------|----------|----------|----------|------------|-------------------------|-------------------|-------|----------|----------|------|----------|
| STEP              | LEVEL 1 | LEVEL 2 | LEVEL 3 | UNIT                | mm      | DRA'N BY  | DES'D BY | CHK'D BY | APP'D BY | MODEL NAME | LTE430WQ-FOC            |                   |       |          |          |      |          |
| 0 < X ≤ 4         | ±0.05   | ±0.1    | ±0.2    | SCALE               | 1 / 1   | T. J. KIM |          |          |          | Y. B. CHU  | PART/SHEET NAME         | OUTLINE DIMENSION | SHEET | 1 / 1    |          |      |          |
| 4 < X ≤ 16        | ±0.08   | ±0.15   | ±0.3    | TOLERANCE           | LEVEL 3 | 07.02.06  |          |          |          | 07.02.06   |                         |                   |       |          |          |      |          |
| 16 < X ≤ 64       | ±0.12   | ±0.25   | ±0.5    | SAMSUNG ELECTRONICS |         |           |          |          |          |            |                         |                   |       | SPEC. NO | CODE NO. | VER. | 000      |
| 64 < X ≤ 256      | ±0.25   | ±0.4    | ±0.8    |                     |         |           |          |          |          |            |                         |                   |       |          |          |      |          |

NO. 10-11-11

## 10. Packing

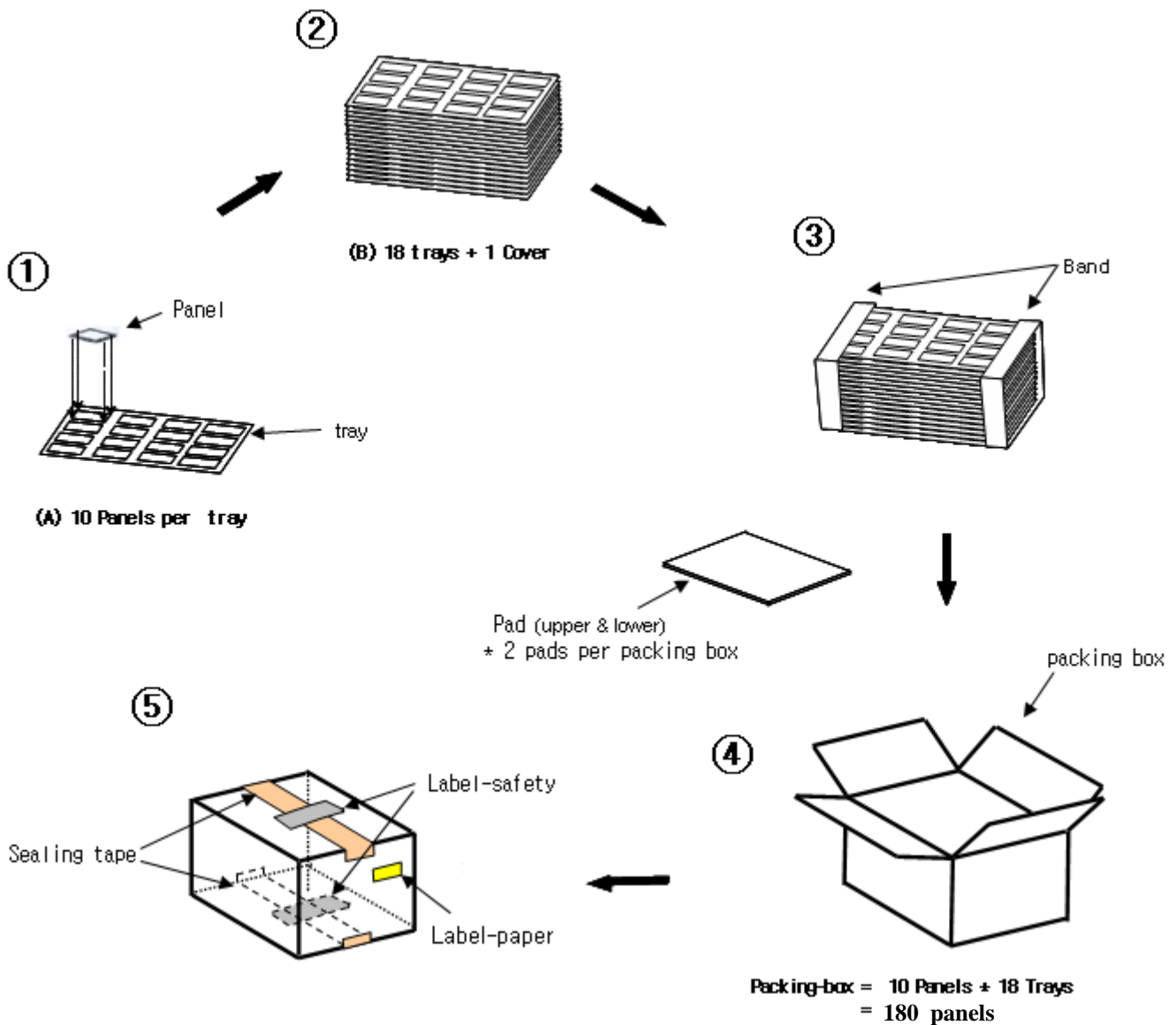

### Note

- (1) Total : Box: Approx. : 13.7 Kg
- (2) Size : Box: 505(W) x 355(D) x 200(H)
- (3) Place the panels in the tray facing the direction shown in the figure.
- (4) Place 18 tray and cover(empty tray) and pads inside the packing-box.
- (5) Seal the packing-box. Affix the label-safety.

### 11. Marking & Others

A nameplate bearing followed by is affixed to a shipped product at the Specified location on each product.

(1) Packing case attach

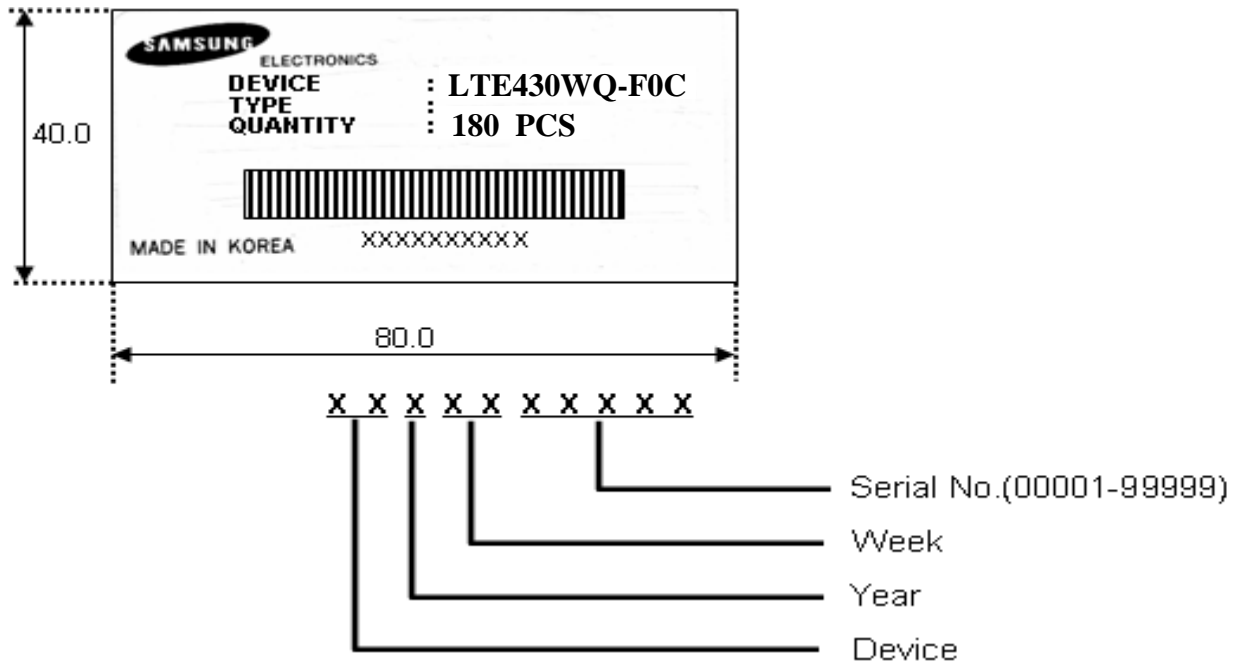

## 12. General Precautions

### 12.1 Handling

- (a) When the module is assembled, it should be attached to the system firmly. Be careful not to twist and bend the module.
- (b) Refrain from strong mechanical shock and / or any force to the module. In addition to damage, this may cause improper operation or damage to the module and back-light unit.
- (c) Note that polarizers are very fragile and could be easily damaged. Do not press or scratch the surface harder than a HB pencil lead.
- (d) Wipe off water droplets or oil immediately. If you leave the droplets for a long time, Staining and discoloration may occur.
- (e) If the surface of the polarizer is dirty, clean it using some absorbent cotton or soft cloth.
- (f) The desirable cleaners are water, IPA(Isopropyl Alcohol) or Hexane. Do not use Ketone type materials(ex. Acetone), Ethyl alcohol, Toluene, Ethyl acid or Methyl chloride. It might permanent damage to the polarizer due to chemical reaction.
- (g) If the liquid crystal material leaks from the panel, it should be kept away from the eyes or mouth. In case of contact with hands, legs or clothes, it must be washed away thoroughly with soap.
- (h) Protect the module from static , it may cause damage to the Integrated Gate Circuit.
- (i) Use finger-stalls with soft gloves in order to keep display clean during the incoming inspection and assembly process.
- (j) Do not disassemble the module.
- (k) Do not adjust the variable resistor which is located on the back side.
- (l) Protection film for polarizer on the module shall be slowly peeled off just before use so that the electrostatic charge can be minimized.
- (m) Pins of I/F connector shall not be touched directly with bare hands

## 12.2 Storage

- (a) Do not leave the panel in high temperature, and high humidity for a long time. It is highly recommended to store the module with temperature from 0 to 35°C and relative humidity of less than 70%.
- (b) Do not store the TFT-LCD module in direct sunlight.
- (c) The module shall be stored in a dark place. It is prohibited to apply sunlight or fluorescent light during the store.

## 12.3 Operation

- (a) Do not connect, disconnect the module in the "Power On" condition.
- (b) Power supply should always be turned on/off by the "Power on/off sequence"
- (c) Module has high frequency circuits. Sufficient suppression to the electromagnetic interference shall be done by system manufacturers. Grounding and shielding methods may be important to minimize the interference.

## 12.4 Others

- (a) The Liquid crystal is deteriorated by ultraviolet, do not leave it in direct sunlight and strong ultraviolet ray for many hours.
- (b) Avoid condensation of water. It may result in improper operation or disconnection of electrode.
- (c) Do not exceed the absolute maximum rating value. ( the supply voltage variation, input voltage variation, variation in part contents and environmental temperature, and so on) Otherwise the panel may be damaged.
- (d) If the panel displays the same pattern continuously for a long period of time, it can be the situation when the image "Sticks" to the screen.
- (e) This panel has its circuitry FPC on the bottom side and should be handled carefully in order not to be stressed.
- (f) Avoid shortness between LED soldering pad and TSP soldering pad.

## 13. Reliability Test Result

| Item                                  | Condition   | Sample Size      | Test Result | Remark        |
|---------------------------------------|---|------------------|-------------|---------------|
| High Temperature Operating Life test  | 70℃ 160HR   | 10EA             | PASS        | Panel surface |
| Low Temperature Operating Life test   | -20℃ 160HR  | 5EA              | PASS        |               |
| Thermal Humidity Bias                 | 60℃ 90%RH 160HR   | 10EA             | PASS        |               |
| On/Off Test                           | 70℃ ⇔ -30℃ (5CYC),  | 10EA             | PASS        | Note(1)       |
| High Temperature Storage test         | 85℃ 160HR   | 5EA              | PASS        | Panel surface |
| Low Temperature Storage test          | -40℃ 160HR  | 5EA              | PASS        |               |
| Wet Humidity Temperature Storage test | 60℃/90%RH 160HR   | 10EA             | PASS        | Panel surface |
| Altitude test                         | Non-operating:188mb/Room Temp.<br>72HR                              | 5EA              | PASS        |               |
| Thermal Cycle storage test            | -40~85℃, 30CYC  | 10EA             | PASS        | Note(2)       |
| Electrical Static Discharge           | Contact:±4kV, 150pF/330Ω<br>Non-contact:±8kV, 150pF/330Ω            | 5EA<br>5EA       | PASS        | Note(3)       |
| Box Vibration                         | Random Vibration MIN-STD 810E,<br>up/down(Z)Axis                    | (1BOX<br>Small)  | PASS        | Note(4)       |
| Box Drop                              | 1 corner, 3 edges, 6 surfaces<br>under 9.1kg:76cm, 9.2~18.2kg: 66cm | (1BOX<br>Medium) | PASS        |               |

Note(1) ON Time over 10 seconds, OFF Time under 10 seconds.

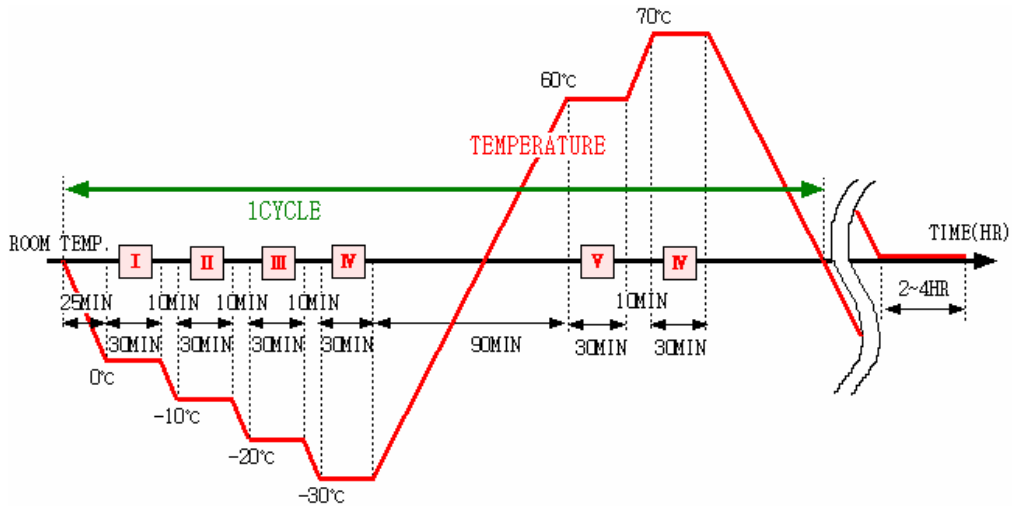

Note(2) STORAGE

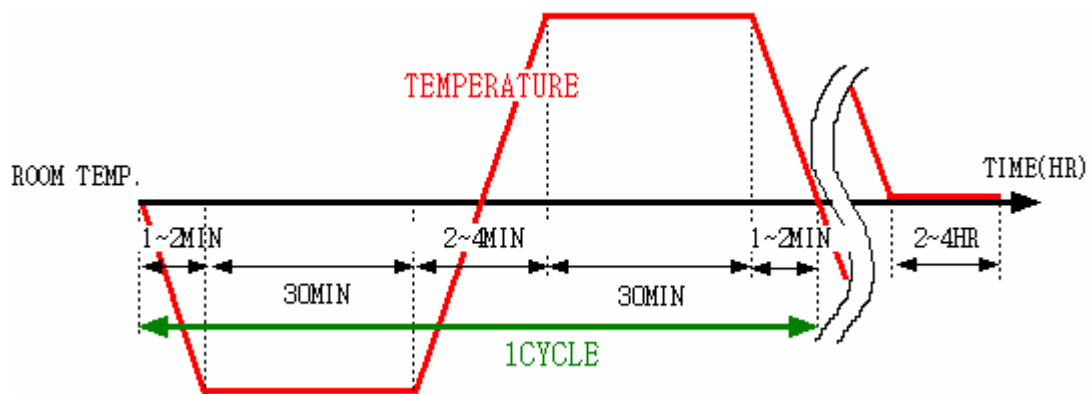

Note(3) Main-LCD, 5 times to every 4 corners of active area.

Note(4) Basic transportation by common carrier environmental, 514.4 MIL-STD-810E.

| OVERALL<br>RMS LEVEL | BREAK POINT |           |           |           |           |           |
|----------------------|-------------|-----------|-----------|-----------|-----------|-----------|
|                      | FREQUENCY   | PSD VALUE | FREQUENCY | PSD VALUE | FREQUENCY | PSD VALUE |
| 0.74G                | 10Hz        | 0.00650   | 121Hz     | 0.00300   | 340Hz     | 0.00003   |
|                      | 20Hz        | 0.00650   | 200Hz     | 0.00300   | 500Hz     | 0.00015   |
|                      | 120Hz       | 0.00020   | 240Hz     | 0.00150   | -         | -         |