

# mass integrated

global part distribution • product lifecycle partner  
excess inventory management • value-ad service provider



Data sheet provided by Mass Integrated

[massintegrated.com](http://massintegrated.com) • [displayalliance.com](http://displayalliance.com)

Please call +1.978.465.6190  
Email: [sales@massintegrated.com](mailto:sales@massintegrated.com)



ISO 9001: 2008

Mass Integrated complies with all DMCA takedown notices. Please send a formal DMCA Takedown Notice to Mass Integrated Systems, Inc. • 18 Henry Graf Jr. Road, Unit 1 • Newburyport, MA 01950.

# TOSHIBA

LIQUID CRYSTAL DISPLAY DIVISION  
PRODUCT INFORMATION

21cm COLOR TFT-LCD MODULE  
(8.4 TYPE)  
**LTM08C351**  
(p-Si TFT)

## FEATURES

- (1) 8.4" SVGA color display with High Brightness (350cd/m<sup>2</sup>).
- (2) Wide viewing angle.
- (3) Built in Long Life CCFLs (MTTF:50,000 h).  
( Conditions / Ta:25°C, I<sub>FL</sub>:6mA(rms)(continuing lighting), f<sub>FL</sub>:40kHz )
- (4) Replaceable structure of lamp units.

**TENTATIVE**

## MECHANICAL SPECIFICATIONS

Item	Specifications
Dimensional Outline (Typ.)	199.5(W) x 149.5(H) x 12.0max(D) mm
Number of Pixels	800 (W) x 600 (H) pixels
Active Area	170.4(W) x 127.8 (H) mm
Pixel Pitch	0.213(W) x 0.213 (H)
Weight (approximately)	(395)g
Backlight	Twin CCFLs, Side-light type

## ABSOLUTE MAXIMUM RATINGS

Item	Min.	Max.	Unit	
Supply Voltage	(V <sub>DD</sub> )	-0.3	4.0	V
	(V <sub>FL</sub> )	0	2.0	kV(rms)
FL Driving Frequency (f <sub>FL</sub> )	-	100	kHz	
Input Signal Voltage (V <sub>IN</sub> )	-0.3	V <sub>DD</sub> +0.3	V	
Operating Temperature	0	50	C	
Storage Temperature	-20	60	C	
Storage Humidity (Max. wet bulb temp. = 39 C)	10	90	%(RH)	

## ELECTRICAL SPECIFICATION

Item	Min.	Typ.	Max.	Unit	Remarks	
Supply Voltage	(V <sub>DD</sub> )	3.0	3.3	3.6	V	
	(V <sub>FL</sub> )	(480)	(530)	(580)	V(rms)	I <sub>FL</sub> =6.0 mA(rms)
FL Start Voltage (Ta=0 C)	1400	---	1600	V(rms)		
High Level Input Voltage (V <sub>IH</sub> )	0.8 V <sub>DD</sub>	---	V <sub>DD</sub>	V		
Low Level Input Voltage (V <sub>IL</sub> )	0	---	0.2 V <sub>DD</sub>	V		
Current Consumption	*1 (I <sub>DD</sub> )	---	(240)	mA		
	*2 (I <sub>FL</sub> )	3.0	---	6.0	mA(rms)	
*1*2 Power Consumption	---	(7.2)	---	W	@350cd/m <sup>2</sup>	

\*1 : 8 color bars pattern

\*2 : Excepting the efficiency FL inverter

## OPTICAL SPECIFICATION (Ta=25 C)

Item	Min.	Typ.	Max.	Unit	Remarks
Contrast Ratio (CR)	100	250	---	---	
Response Time	(t <sub>ON</sub> )	---	50	ms	
	(t <sub>OFF</sub> )	---	50	ms	
Luminance (L)	(280)	(350)	---	cd/m <sup>2</sup>	I <sub>FL</sub> =6.0mA(rms)

\*The information contained herein is presented only as a guide for the applications of our products. No responsibility is assumed by Toshiba or other rights of the third parties which may result from its use. No license is granted by implication or otherwise under any patent or patent rights of Toshiba or others.

\*The information contained herein may be changed without prior notice. It is therefore advisable to contact Toshiba before proceeding with the design of equipment incorporating this product.

Unit : mm

Standard tolerance : ±0.5

**DIMENSIONAL OUTLINE (front figure)**

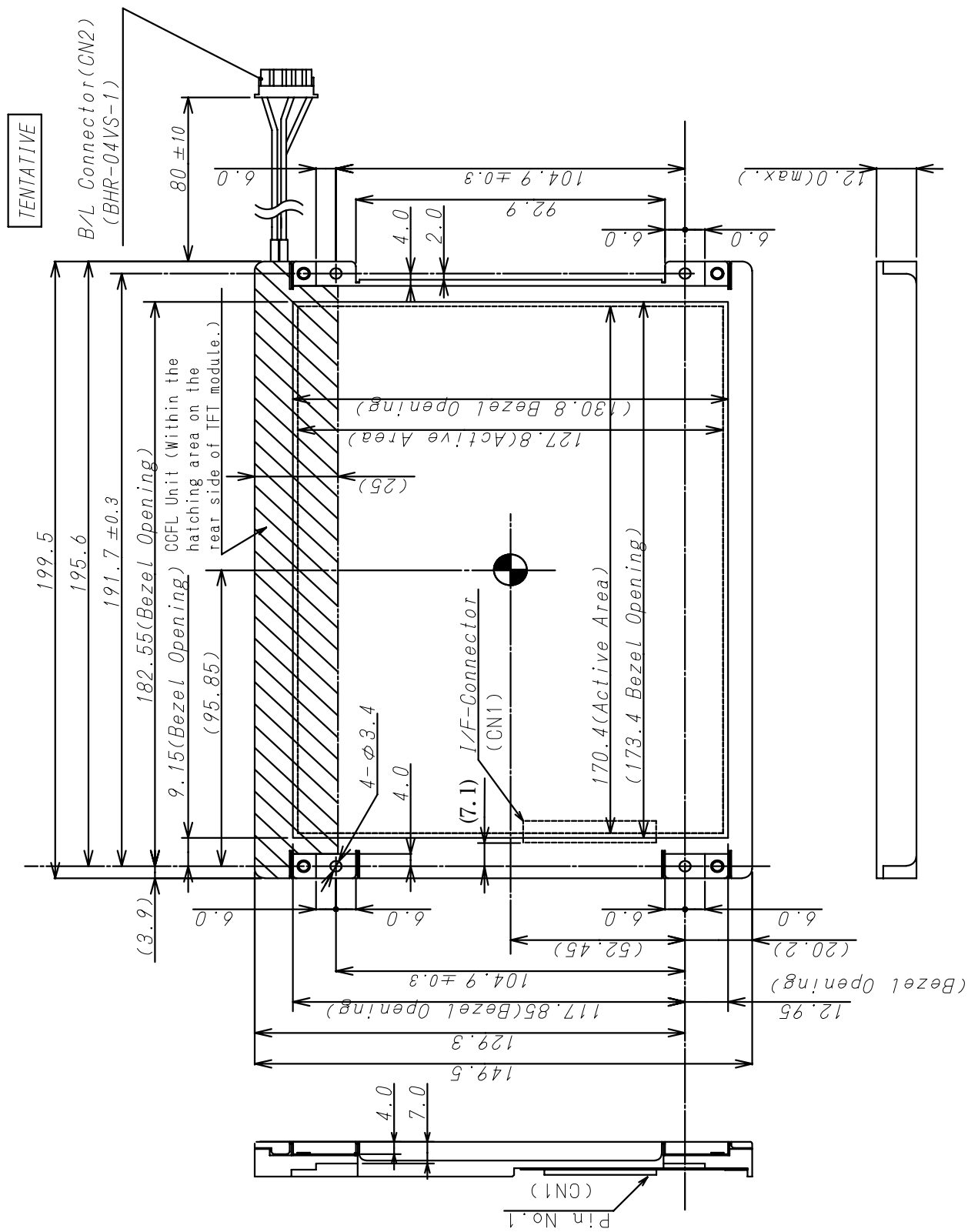

**BLOCK DIAGRAM**

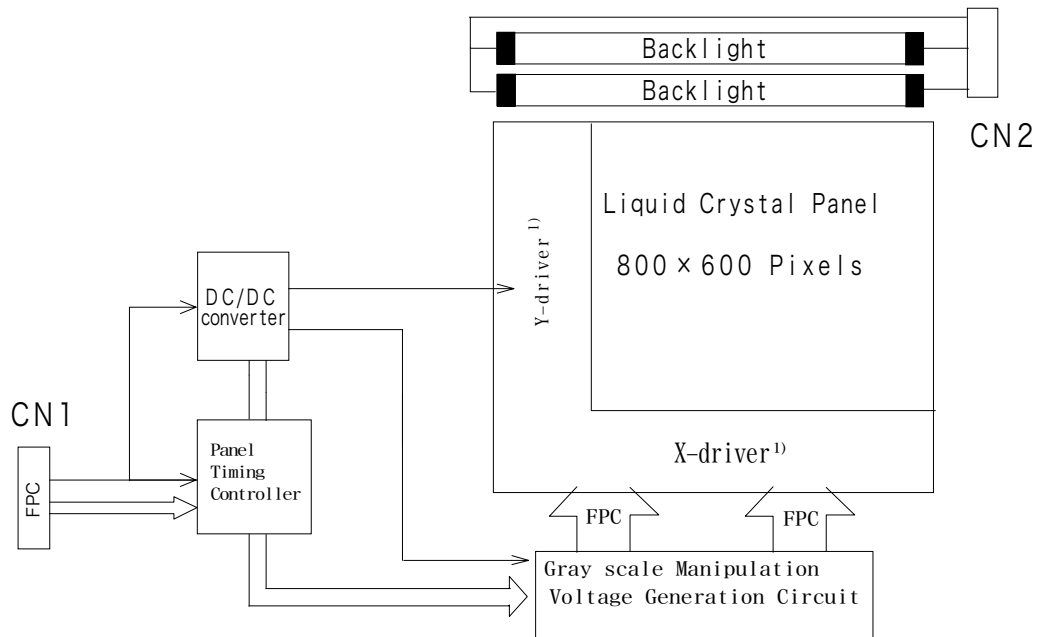

Note1) Build up LCD drivers on the glass substrate

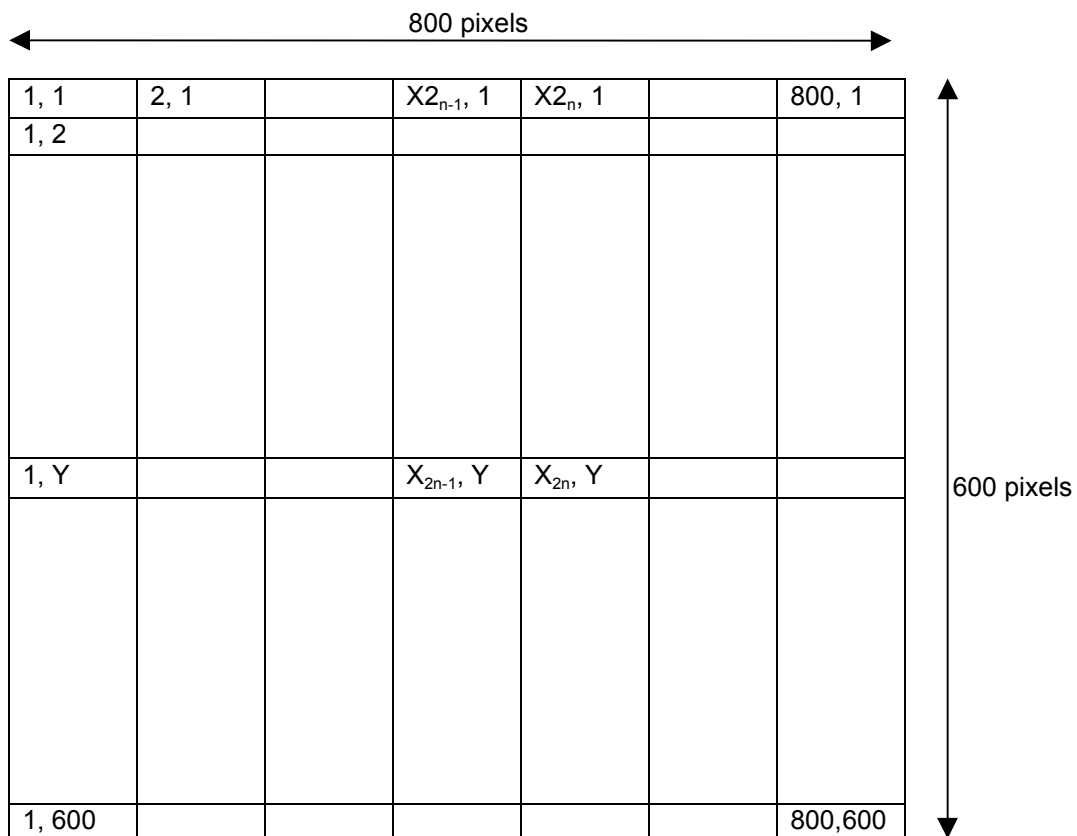

TIMING CHART

(1) Vertical Timing

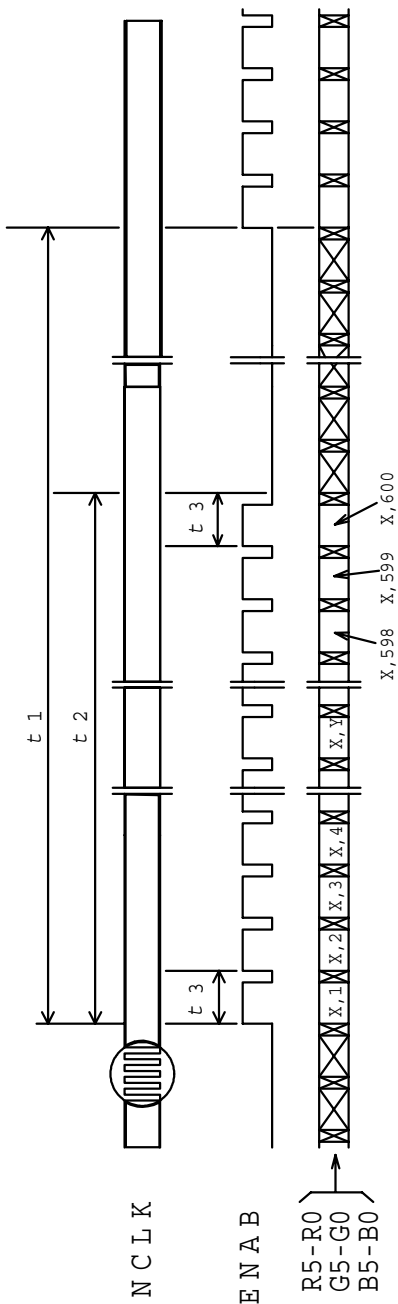

(2) Horizontal Timing

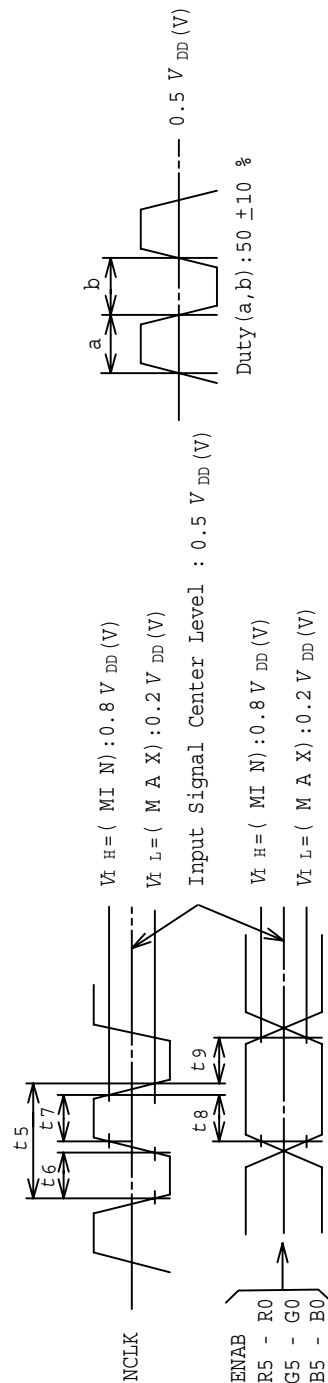
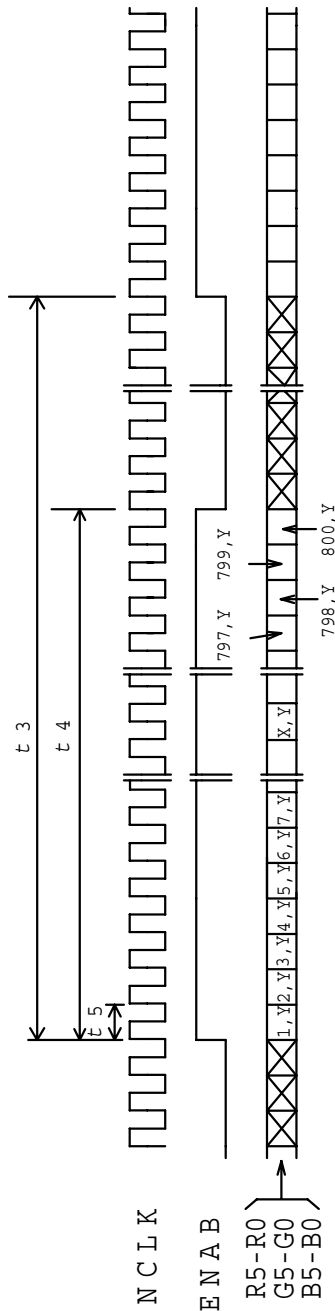

**TIMING SPECIFICATION** <sup>1) 2) 3) 4)</sup>

Item	Symbol	Min.	Typ.	Max.	Unit	Remarks
Frame Period	$t_1$	$604 \times t_3$	$628 \times t_3$ 16.58	$677 \times t_3$ 17.86	---	1)
Vertical Display Term	$t_2$	$600 \times t_3$	$600 \times t_3$	$600 \times t_3$	---	1)
One Line Scanning Time	$t_3$	$944 \times t_5$ 26.3	$1056 \times t_5$ 26.4	$1064 \times t_5$ ---	---	1)
Horizontal Display Term	$t_4$	$800 \times t_5$	$800 \times t_5$	$800 \times t_5$	---	1)
Clock Period	$t_5$	24.7	25.0	27.8	ns	
Clock "L" Time	$t_6$	9.0	---	---	ns	
Clock "H" Time	$t_7$	9.0	---	---	ns	
Set Up Time	$t_8$	4.0	---	---	ns	
Hold Time	$t_9$	5.0	---	---	ns	

Note 1) When ENAB is fixed to "H" level or "L" level after NCLK input, the panel displays black with some flicker.

Note 2) Do not fix NCLK to "H" or "L" level while the VDD(+3.3V) is supplied.

If NCLK is fixed to "H" or "L" level for certain period while ENAB is supplied, the panel may be damaged.

Note 3) Please adjust LCD operating signal timing and FL driving frequency, to optimize the display quality. There is a possibility that flicker is observed by the interference of LCD operating signal timing and FL driving condition (especially driving frequency).

Note 4) Do not make  $t_1, t_2$  and  $t_3$  fluctuate.

If  $t_1, t_2$  and  $t_3$  are fluctuate, the panel displays black.

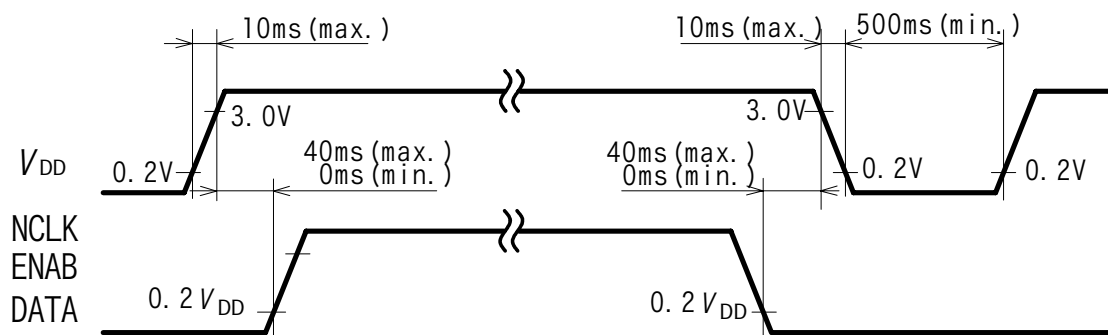
**SEQUENCE OF POWER SUPPLIES AND SIGNALS**

## CONNECTOR PIN ASSIGNMENT FOR INTERFACE

### CN1 INPUT SIGNAL

Connector : DF19G-30P-1H/HIROSE ELECTRIC CO., LTD.

Mating Connector : DF19G-30S-1C(housing),DF19-2830SCFA(contact pin)/HIROSE ELECTRIC CO., LTD.

Terminal No.	Symbol	Function
1	GND	
2	V <sub>DD</sub>	+3.3V POWER SUPPLY
3	V <sub>DD</sub>	+3.3V POWER SUPPLY
4	GND	
5	ENAB	COMPOUND SYNCHRONIZATION SIGNAL
6	B5 <sup>2)</sup>	BLUE DISPLAY DATA (MSB)
7	B4 <sup>2)</sup>	BLUE DISPLAY DATA
8	B3 <sup>2)</sup>	BLUE DISPLAY DATA
9	B2 <sup>2)</sup>	BLUE DISPLAY DATA
10	B1 <sup>2)</sup>	BLUE DISPLAY DATA
11	B0 <sup>2)</sup>	BLUE DISPLAY DATA (LSB)
12	GND	
13	G5 <sup>2)</sup>	GREEN DISPLAY DATA (MSB)
14	G4 <sup>2)</sup>	GREEN DISPLAY DATA
15	G3 <sup>2)</sup>	GREEN DISPLAY DATA
16	G2 <sup>2)</sup>	GREEN DISPLAY DATA
17	G1 <sup>2)</sup>	GREEN DISPLAY DATA
18	G0 <sup>2)</sup>	GREEN DISPLAY DATA (LSB)
19	GND	
20	R5 <sup>2)</sup>	RED DISPLAY DATA (MSB)
21	R4 <sup>2)</sup>	RED DISPLAY DATA
22	R3 <sup>2)</sup>	RED DISPLAY DATA
23	R2 <sup>2)</sup>	RED DISPLAY DATA
24	R1 <sup>2)</sup>	RED DISPLAY DATA
25	R0 <sup>2)</sup>	RED DISPLAY DATA (LSB)
26	GND	
27	NC <sup>1)</sup>	
28	NC <sup>1)</sup>	
29	NCLK	SAMPLING CLOCK
30	GND	

### CN2 CCFL POWER SOURCE

Connector : BHR-04VS-1/JAPAN SOLDERLESS TERMINAL MFG CO., LTD.

Mating Connector : SM04(4.0)B-BHS-1-TB/JAPAN SOLDERLESS TERMINAL MFG CO., LTD.

Terminal No.	Symbol	Function
1	VFLH	CCFL POWER SUPPLY (HIGH VOLTAGE)
2	VFLH	CCFL POWER SUPPLY (HIGH VOLTAGE)
3	NC <sup>1)</sup>	
4	VFLL	CCFL POWER SUPPLY (LOW VOLTAGE)

Note 1) NC Terminal is open. (Don't use)

Note 2) See next page.

256k (k=1024) COLORS COMBINATION TABLE

	Display	R5 R4 R3 R2 R1 R0	G5 G4 G3 G2 G1 G0	B5 B4 B3 B2 B1 B0	Gray Scale Level
Basic Color	Black	L L L L L L	L L L L L L	L L L L L L	-
	Blue	L L L L L L	L L L L L L	H H H H H H	-
	Green	L L L L L L	H H H H H H	L L L L L L	-
	Light Blue	L L L L L L	H H H H H H	H H H H H H	-
	Red	H H H H H H	L L L L L L	L L L L L L	-
	Purple	H H H H H H	L L L L L L	H H H H H H	-
	Yellow	H H H H H H	H H H H H H	L L L L L L	-
Gray Scale of Red	White	H H H H H H	H H H H H H	H H H H H H	-
	Black	L L L L L L	L L L L L L	L L L L L L	L 0
	Dark ↑ ↓ Light	L L L L L H	L L L L L L	L L L L L L	L 1
		L L L L H L	L L L L L L	L L L L L L	L 2
		: :	: :	: :	L3 L60
		H H H H L H	L L L L L L	L L L L L L	L61
		H H H H H L	L L L L L L	L L L L L L	L62
Red	H H H H H H	L L L L L L	L L L L L L	Red L63	
Gray Scale of Green	Black	L L L L L L	L L L L L L	L L L L L L	L 0
	Dark ↑ ↓ Light	L L L L L L	L L L L L H	L L L L L L	L 1
		L L L L L L	L L L L H L	L L L L L L	L 2
		: :	: :	: :	L3 L60
		L L L L L L	H H H H L H	L L L L L L	L61
		L L L L L L	H H H H H L	L L L L L L	L62
	Green	L L L L L L	H H H H H H	L L L L L L	Green L63
Gray Scale of Blue	Black	L L L L L L	L L L L L L	L L L L L L	L 0
	Dark ↑ ↓ Light	L L L L L L	L L L L L L	L L L L L H	L 1
		L L L L L L	L L L L L L	L L L L H L	L 2
		: :	: :	: :	L3 L60
		L L L L L L	L L L L L L	H H H H L H	L61
		L L L L L L	L L L L L L	H H H H H L	L62
	Blue	L L L L L L	L L L L L L	H H H H H H	Blue L63
Gray Scale of White & Black	Black	L L L L L L	L L L L L L	L L L L L L	L 0
	Dark ↑ ↓ Light	L L L L L H	L L L L L H	L L L L L H	L 1
		L L L L H L	L L L L H L	L L L L H L	L 2
		: :	: :	: :	L3 L60
		H H H H L H	H H H H L H	H H H H L H	L61
		H H H H H L	H H H H H L	H H H H H L	L62
	White	H H H H H H	H H H H H H	H H H H H H	White L63

**FOR SAFETY**

LCD module is generally designed with precise parts to achieve light weighted thin mechanical dimensions. In using our Modules, make certain that you fully understand and put into practice the warnings and safety precautions detailed in Engineering Information No.EE-N001,"CAUTIONS AND INSTRUCTIONS FOR TOSHIBA LCD MODULES". Refer to individual specifications and TECHNICAL DATA sheets (hereinafter called "TD") for more detailed technical information.

**1) SPECIAL PURPOSES**

A) Toshiba's Standard LCD Modules have not been customized for operation in extreme environments or for use in applications where performance failures could be life-threatening or otherwise catastrophic.

B) Since Toshiba's Standard LCD Modules have not been designed for operation in extreme environments, they must never be used in devices that will be exposed to abnormally high levels of vibration or shock which exceed Toshiba's published specification limits.

C) In addition, since Toshiba Standard LCD Modules have not been designed for use in applications where performance failures could be life-threatening or catastrophic, they must never be installed in aircraft navigation control systems (such as, but not limited to Traffic Collision Avoidance System and Air Traffic Indicator), in military defense or weapons systems, in critical industrial process-control systems (e.g., those involved in the production of nuclear energy), or in critical medical device or patient life-support systems.

**2) DISASSEMBLING OR MODIFICATION**

DO NOT DISASSEMBLE OR MODIFY the module. It may damage sensitive parts inside LCD module, and may cause scratches or dust on the display.

Toshiba does not warrant the module, if customer disassembled or modified it.

**3) BREAKAGE OF LCD PANEL**

DO NOT INGEST liquid crystal material, DO NOT INHALE this material, and DO NOT CONTACT the material with skin, if LCD panel is broken and liquid crystal material spills out.

If liquid crystal material comes into mouth or eyes, rinse mouth or eyes out with water immediately.

If this material contact with skin or cloths, wash it off immediately with alcohol and rinse thoroughly with water.

**4) GLASS OF LCD PANEL**

BE CAREFUL WITH CHIPS OF GLASS that may cause injuring fingers or skin, when the glass is broken.

**5) ELECTRIC SHOCK**

DISCONNECT POWER SUPPLY before handling LCD module.

DO NOT TOUCH the parts inside LCD module and the fluorescent lamp's connector or cables in order to prevent electric shock, because high voltage is supplied to these parts from the inverter unit while power supply is turned on.

**6) ABSOLUTE MAXIMUM RATINGS AND POWER PROTECTION CIRCUIT**

DO NOT EXCEED the absolute maximum rating values under the worst probable conditions caused by the supply voltage variation, input voltage variation, variation in parts' constants, environmental temperature, etc., otherwise LCD module may be damaged.

Employ protection circuit for power supply, whenever the specification or TD specifies it.

Suitable protection circuit should be applied for each system design.

**7) DISPOSAL**

When dispose LCD module, obey to the applicable environmental regulations.