

mass integrated

global part distribution • product lifecycle partner
excess inventory management • value-ad service provider



Data sheet provided by Mass Integrated

massintegrated.com • displayalliance.com

Please call +1.978.465.6190
Email: sales@massintegrated.com



ISO 9001: 2008

Mass Integrated complies with all DMCA takedown notices. Please send a formal DMCA Takedown Notice to Mass Integrated Systems, Inc. • 18 Henry Graf Jr. Road, Unit 1 • Newburyport, MA 01950.



ELECTRONICS

Preliminary



TO : [Redacted]
DATE : Oct. 13, 2009

SAMSUNG TFT-LCD
MODEL NO. : LTN101NT02-306

NOTE : Extension code [-A]
→ LTN101NT02-306
Surface type [**Anti-Glare**]

Any modification of spec is not allowed without SEC's permission.

APPROVED BY : _____

PREPARED BY : **Mia So** _____

Application Engineer part 1, Device Solution (LCD)
SAMSUNG ELECTRONICS CO., LTD.

Samsung Secret

CONTENTS

Revision History	----- (3)
General Description	----- (4)
1. Absolute Maximum Ratings	----- (5)
1.1 Absolute Ratings of environment	
1.2 Electrical Absolute Ratings	
2. Optical Characteristics	----- (7)
3. Electrical Characteristics	----- (10)
3.1 TFT LCD Module	
3.2 Backlight Unit	
3.3 LED Driver	
4. Block Diagram	----- (13)
4.1 TFT LCD Module	
4.2 LED Placement Structure	
5. Input Terminal Pin Assignment	----- (14)
5.1 Input Signal & Power	
5.2 LVDS Interface	
5.3 Timing Diagrams of LVDS For Transmitting	
5.4 Input Signals, Basic Display Colors and Gray Scale of Each Color.	
5.5 Pixel format	
6. Interface Timing	----- (20)
6.1 Timing Parameters	
6.2 Timing Diagrams of interface Signal	
6.3 Power ON/OFF Sequence	
7. Outline Dimension	----- (22)
8. Packing	----- (24)
9. Markings & Others	----- (25)
10. General Precautions	----- (27)

REVISION HISTORY

Preliminary

Date	Revision No.	Page	Summary
Oct, 08. 2009	P00	All	The Preliminary specification of LTN101NT02-301 was issued first.
Oct, 13. 2009	P01	All	Revision code was changed to '306' from '301' Outline drawing was updated.

Samsung Secret

GENERAL DESCRIPTION

DESCRIPTION

LTN101NT02 is a color active matrix TFT (Thin Film Transistor) liquid crystal display (LCD) that uses amorphous silicon TFT as switching devices. This model is composed of a TFT LCD panel, a driver circuit and a backlight unit. The resolution of a 10.1" contains 1024 x 600 pixels and can display up to 262,144 colors. 6 O'clock direction is the optimum viewing angle.

FEATURES

- High contrast ratio
- SD (1024 x 600 pixels) resolution
- Low power consumption
- Fast Response
- LED Back Light with embedded LED Driver
- DE (Data enable) only mode
- 3.3V LVDS Interface
- Onboard EEDID chip
- Green product (RoHS compliant)

APPLICATIONS

- Notebook PC
- If the usage of this product is not for PC application, but for others, please contact SEC

GENERAL INFORMATION

Item	Specification	Unit	Note
Display area	222.72(H) x 125.28(V) (10.1" wide diagonal)	mm	
Driver element	a-Si TFT active matrix		
Display colors	262,144		
Number of pixel	1024 x 600	pixel	
Pixel arrangement	RGB vertical stripe		
Pixel pitch	0.2175(H) x 0.2088(V) (TYP.)	mm	
Display Mode	Normally white		
Surface treatment	Haze 25, Hard-Coating 3H		

Samsung Secret

Mechanical Information

Item		Min.	Typ.	Max.	Unit	Note
Module size	Horizontal (H)	234.5	235.0	235.5	mm	
	Vertical (V)	142.5	143.0	143.5	mm	
	Depth (D)	-	5.0	5.2	mm	(1)
Weight		-	190	200	g	

Note (1) Measurement condition of outline dimension
 . Equipment : Bernier Calipers
 . Push Force : 500g · f (minimum)

1. ABSOLUTE MAXIMUM RATINGS

1.1 ENVIRONMENTAL ABSOLUTE RATINGS

Item	Symbol	Min.	Max.	Unit	Note
Storage temperate	TSTG	-20	60	°C	(1)
Operating temperate (Temperature of glass surface)	TOPR	0	50	°C	(1)
Shock (non-operating)	Snop	-	240	G	(2),(4)
Vibration (non-operating)	Vnop	-	2.41	G	(3),(4)

Note (1) Temperature and relative humidity range are shown in the figure below.
 95 % RH Max. (40 °C ≥ Ta)
 Maximum wet - bulb temperature at 39 °C or less. (Ta > 40 °C) No condensation

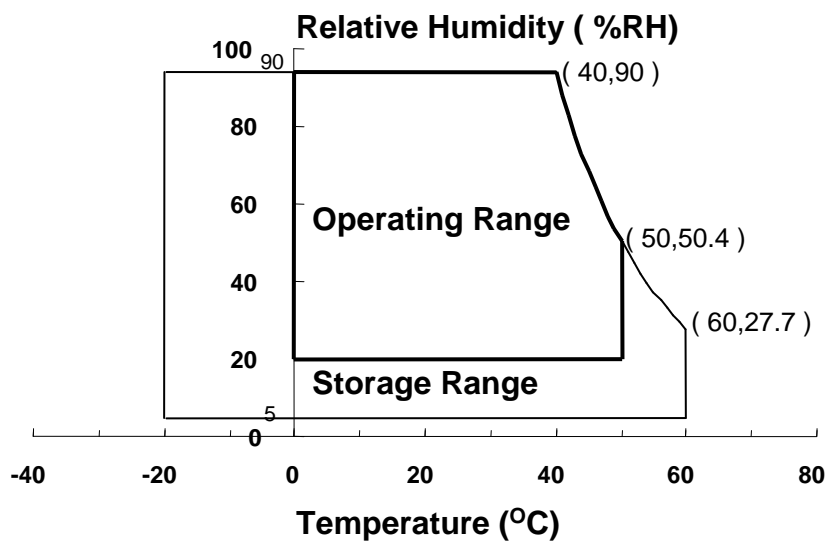

- (2) 2ms, half sine wave, one time for ±X, ±Y, ±Z.
- (3) 5 - 500 Hz, random vibration, 30min for X, Y, Z.
- (4) At testing Vibration and Shock, the fixture in holding the Module to be tested have to be hard and rigid enough so that the Module would not be twisted or bent by the fixture.

Samsung Secret

1.2 ELECTRICAL ABSOLUTE RATINGS

(1) TFT LCD MODULE

 $V_{DD} = 3.3V, V_{SS} = GND = 0V$

Item	Symbol	Min.	Max.	Unit	Note
Power Supply Voltage	V_{DD}	$V_{DD} - 0.3$	$V_{DD} + 0.3$	V	(1)
Logic Input Voltage	V_{IN}	$V_{DD} - 0.3$	$V_{DD} + 0.3$	V	(1)

Note (1) Within T_a (25 ± 2 °C)

2. OPTICAL CHARACTERISTICS

The following items are measured under stable conditions. The optical characteristics should be measured in a dark room or equivalent state with the methods shown in Note (5).
Measuring equipment : TOPCON SR-3

* Ta = 25 ± 2 °C, VDD=3.3V, fv= 60Hz, fdCLK = 58.8MHz, IL = 22.0 mA

Item		Symbol	Condition	Min.	Typ.	Max	Unit	Note
Contrast Ratio (5 Points)		CR	Normal Viewing Angle $\phi = 0$ $\theta = 0$	-	300	-	-	(1), (2), (5)
Response Time at Ta (Rising + Falling)		T _{RT}		-	16	25	msec	(1), (3)
Average Luminance of White (5 Points)		Y _{L,AVE}		170	200	-	cd/m ²	IL=22.0mA (1), (4)
Color Chromaticity (CIE)	Red	R _X	CR ≥ 10 At center	0.559	0.589	0.619	-	(1), (5) SR-3
		R _Y		0.318	0.348	0.378		
	Green	G _X		0.305	0.335	0.365		
		G _Y		0.542	0.572	0.602		
	Blue	B _X		0.129	0.159	0.189		
		B _Y		0.087	0.117	0.147		
	White	W _X		0.283	0.313	0.343		
		W _Y		0.299	0.329	0.359		
Viewing Angle	Hor.	θ_L	40	45		Degrees	(1), (5) SR-3	
		θ_H	40	45				
	Ver.	ϕ_H	15	20				
		ϕ_L	35	40				
Color Gamut		CG		42	45		%	
13 Points White Variation		δ_L		-	-	1.7	-	(6)

Samsung Secret

Note 1) Definition of Viewing Angle : Viewing angle range($10 \leq C/R$)

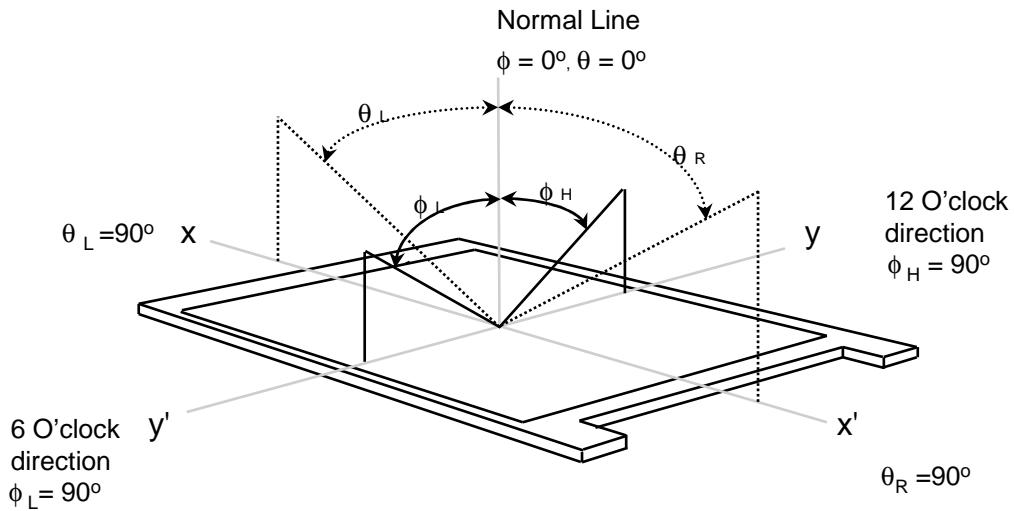

Note 2) Definition of Contrast Ratio (CR) : Ratio of gray max (Gmax) ,gray min (Gmin) at 5 points(4, 5, 7, 9, 10)

$$CR = \frac{CR(4) + CR(5) + CR(7) + CR(9) + CR(10)}{5}$$

Points : (4) , (5) , (7) , (9) , (10) at the figure of Note (6).

Note 3) Definition of Response time :

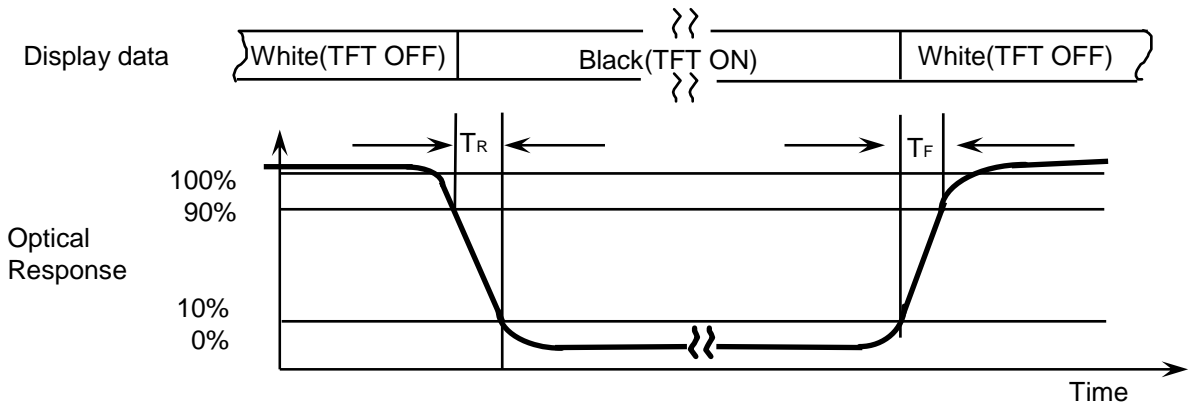

Note 4) Definition of Average Luminance of White : measure the luminance of white at 5 points.

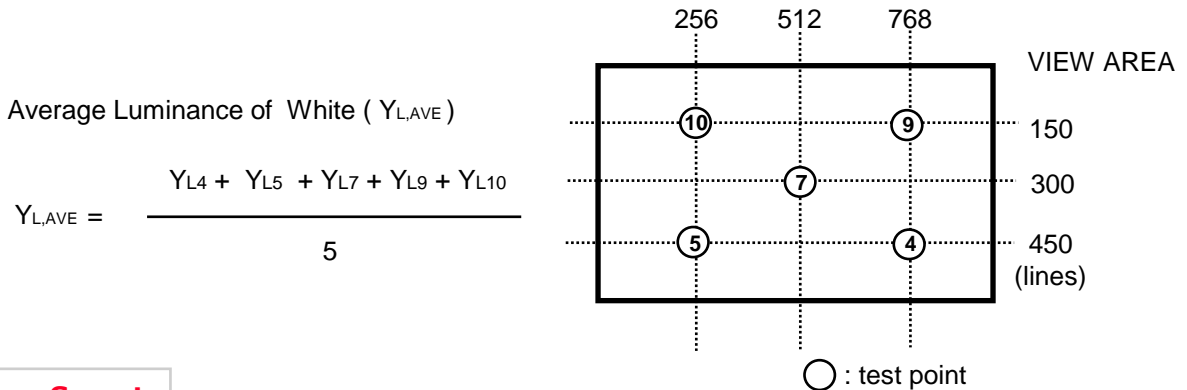

Note 5) After stabilizing and leaving the panel alone at a given temperature for 30 min , the measurement should be executed. Measurement should be executed in a stable, windless, and dark room. 30 min after lighting the backlight. This should be measured in the center of screen.

LED current : 22.0mA

Environment condition : $T_a = 25 \pm 2 \text{ }^\circ\text{C}$

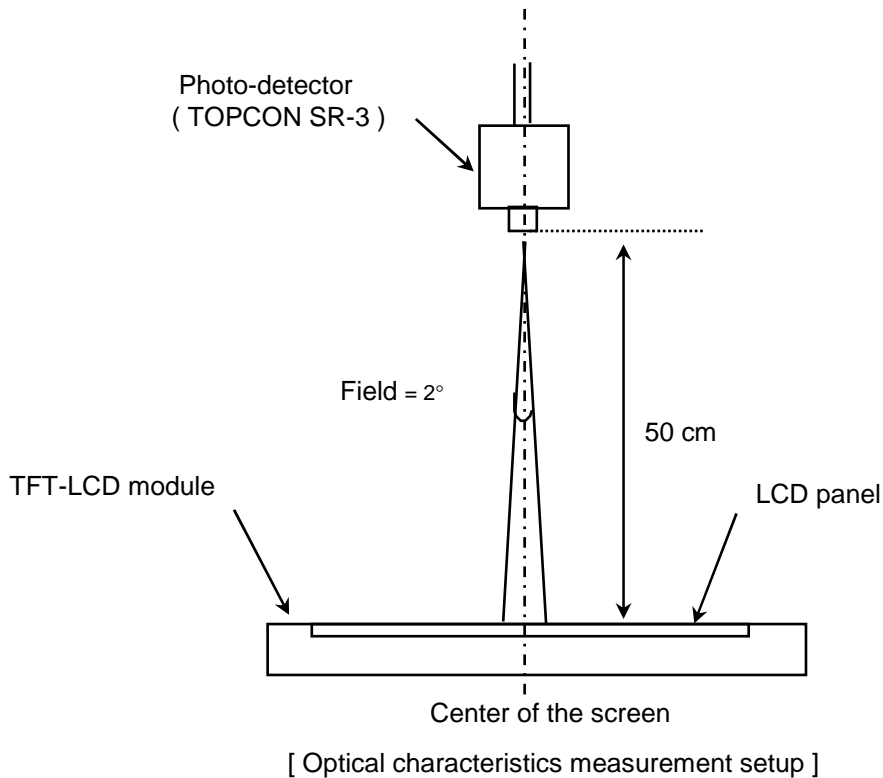

Note 6) Definition of 13 points white variation (δL), CR variation(C_{VER}) [① ~ ⑬]

$$\delta L = \frac{\text{Maximum luminance of 13 points}}{\text{Minimum luminance of 13 points}}$$

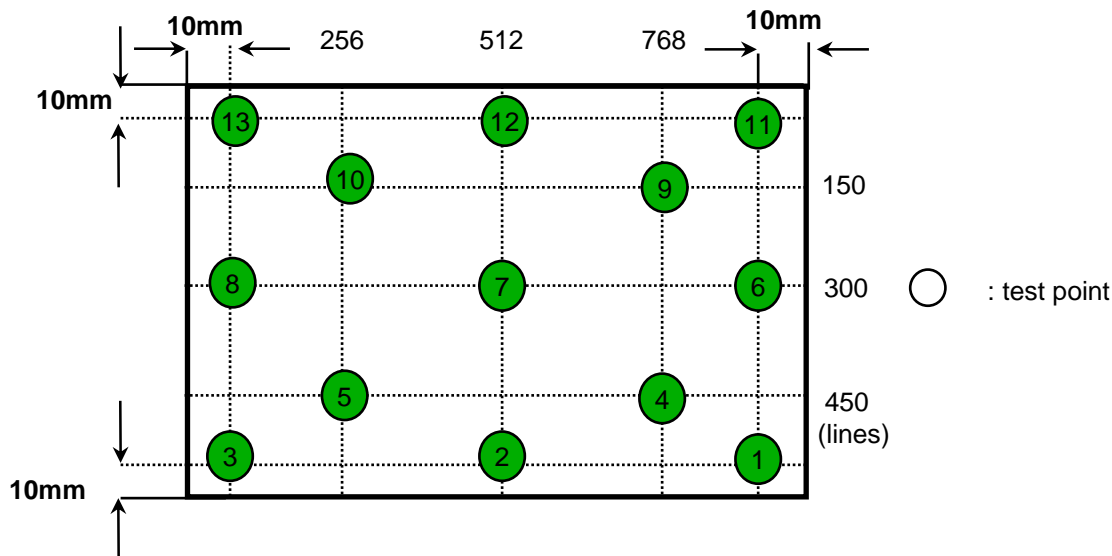

Samsung Secret

3. ELECTRICAL CHARACTERISTICS

3.1 TFT LCD MODULE

Ta= 25 ± 2°C

Item	Symbol	Min.	Typ.	Max.	Unit	Note	
Voltage of Power Supply	V _{DD}	3.0	3.3	3.6	V		
Differential Input Voltage for LVDS Receiver Threshold	High	V _{IH}	-	-	+100	mV	V _{CM} = +1.2V
	Low	V _{IL}	-100	-	-	mV	
Vsync Frequency	f _v	-	60	-	Hz		
Hsync Frequency	f _H	-	40.32	-	KHz		
Main Frequency	f _{DCLK}	-	54.2	-	MHz		
Rush Current	I _{RUSH}	-	-	1.5	A	(4)	
Current of Power Supply	White	I _{DD}	-	190	-	mA	(2),(3)*a
	Mosaic		-	250	-	mA	(2),(3)*b
	V. stripe		-	270	310	mA	(2),(3)*c

Note (1) Display data pins and timing signal pins should be connected.(GND = 0V)

(2) f_v = 60Hz, f_{DCLK} = 58.8MHz, V_{DD} = 3.3V , DC Current.

(3) Power dissipation pattern

*a) White Pattern

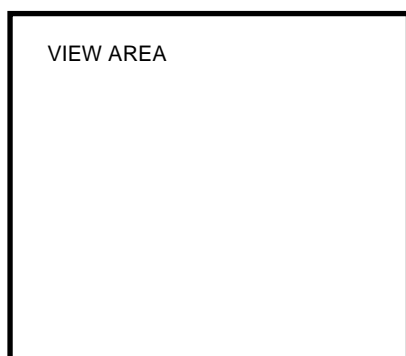

*b) Mosaic Pattern

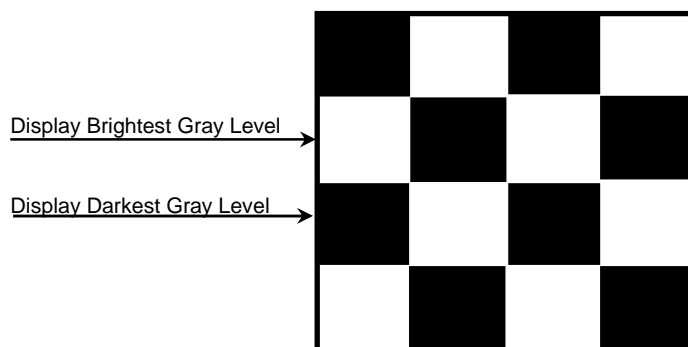

*c) 1dot Vertical stripe pattern

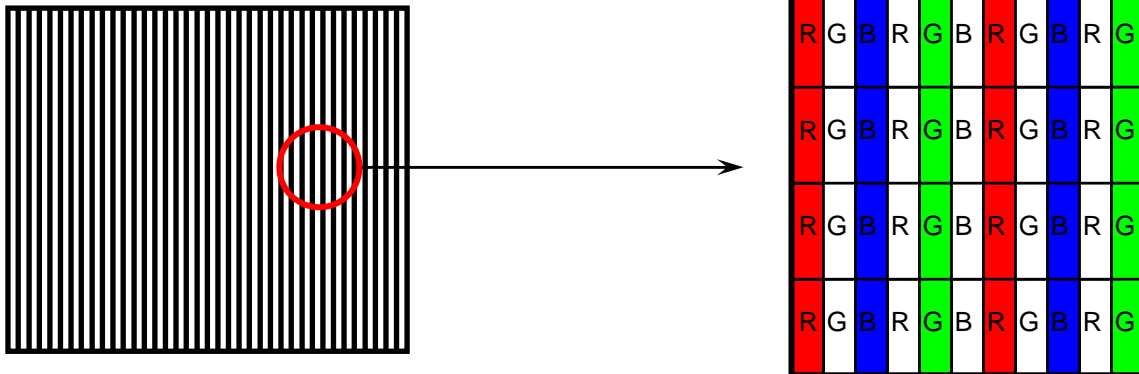

4) Rush current measurement condition

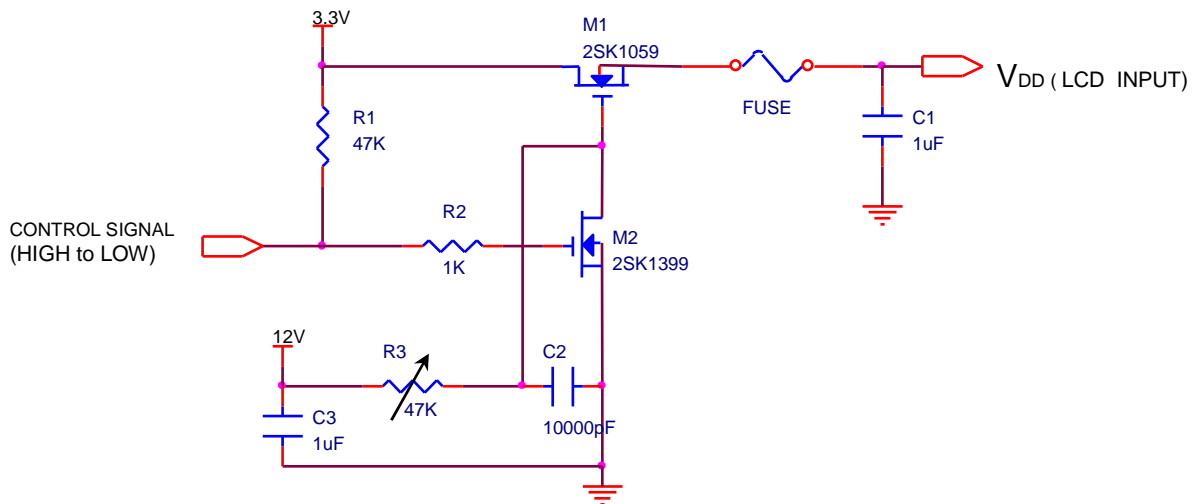

V_{DD} rising time is 470us

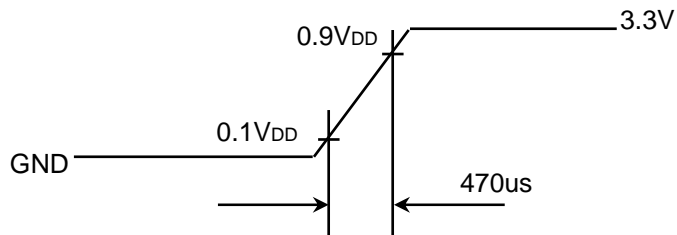

Samsung Secret

3.2 BACK-LIGHT UNIT

Ta= 25 ± 2 °C

Item	Symbol	Min.	Typ.	Max.	Unit	Note
LED Forward Current	IF	-	22	-	mA	
LED Forward Voltage	VF	3.0	3.2	3.4	V	
LED Array Voltage	VP	27.0	28.8	30.6	V	VF X 9 LEDs
Power Consumption	P	1.0	1.4	1.8	W	IF X VF X 18LEDs
Operating Life Time	Hr	10000	-	-	Hour	(1)

Note (1) Life time (Hr) of LEDs can be defined as the time in which it continues to operate under the condition Ta= 25 ± 2 °C and IF = 22.0 mArms until one of the following event occurs.

1. When the brightness becomes 50% or lower than the original.

3.3 LED Driver

- On board LED Driver (Manufacturer : Richtek)

Ta= 25 ± 2 °C

Item	Symbol	Min.	Typ.	Max.	Unit	Note
Input Voltage	V _{in}	7.0	12.0	21.0	V	
Input Current	I	-	160	-	mA	
Input Power	P _{in}	-	1.9	2.2	W	
Operating Frequency	F _o	0.8	1.0	1.2	MHz	
Duty Ratio	D	10	-	100	%	PWM Freq: 1KHz~20KHz
		5	-	100		200Hz~1KHz
External PWM Dimming Control Frequency (BLIM)	F _{BLIM}	-	1	10	kHz	V _{in} =7~20V, BLIM=PWM 0V~3.3V
Output Power	P _{out}	-	-	1.8	W	BLIM=100%
Efficiency	η	82	88	94	%	BLIM=100%

Note (1) Test Equipment : Fluke 45

- (2) SEC guarantee PWM frequency from 0.2kHz to 10KHz

4. BLOCK DIAGRAM

4.1 TFT LCD Module

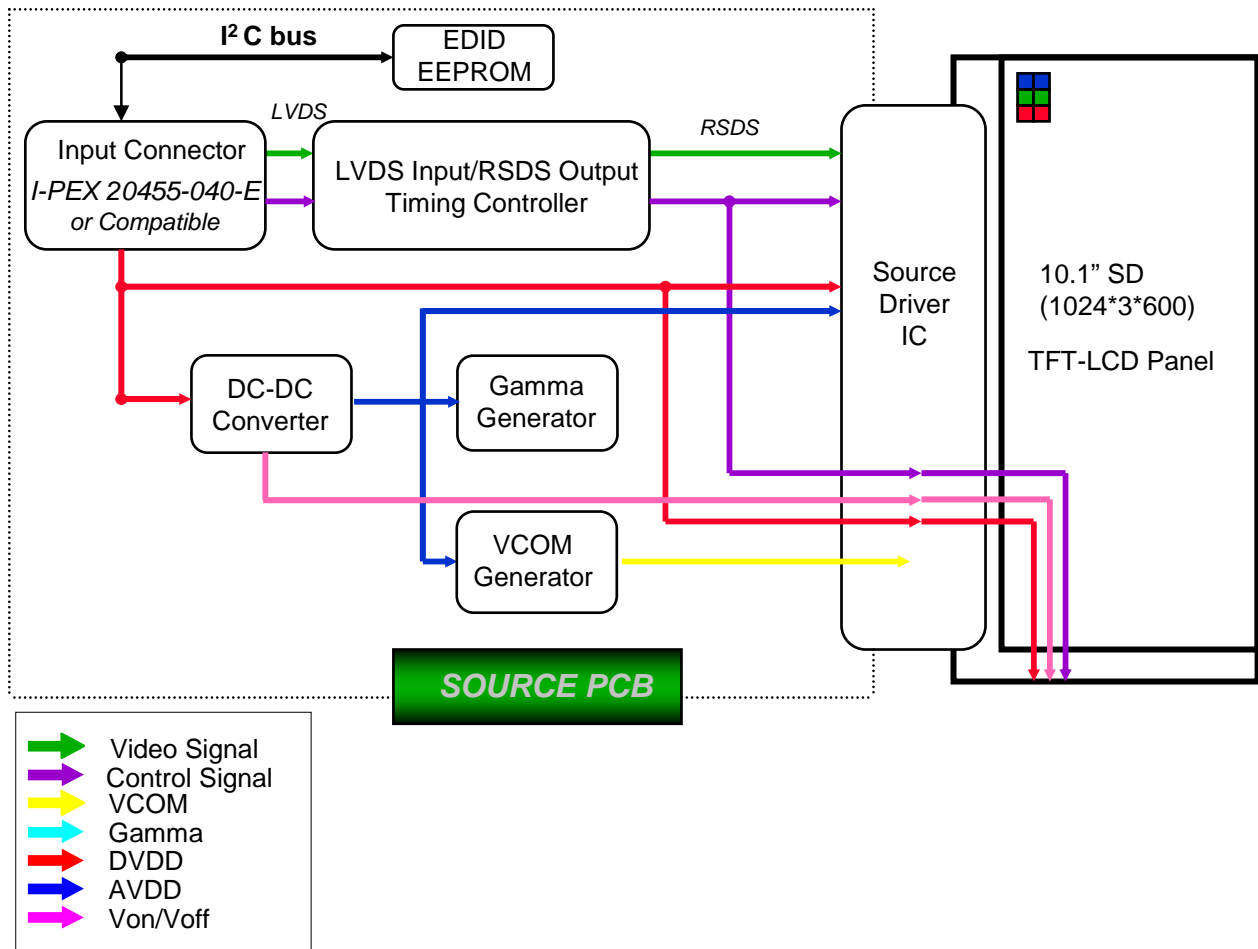

4.2 LED placement structure

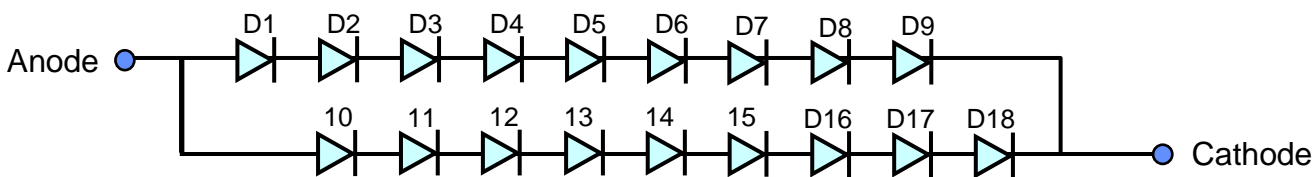

5. INPUT TERMINAL PIN ASSIGNMENT

5.1. Input Signal & Power (LVDS, Connector : I-PEX 20455-040E-## or equivalent)

No.	Symbol	Function	Polarity	Remarks
1	NC	No Connect		
2	VDD	Power Supply +3.3V		
3	VDD	Power Supply +3.3V		
4	VEDID	EDID +3.3V Power		
5	NC	No Connect		
6	CLK_EDID	EDID Clock Input		
7	DATA_EDID	EDID Data Input		
8	RxOIN0-	-LVDS Differential Data (Odd R0-R5, G0)	Negative	
9	RxOIN0+	+LVDS Differential Data (Odd R0-R5, G0)	Positive	
10	VSS	Ground		
11	RxOIN1-	-LVDS Differential Data (Odd G1-G5,B0-B1)	Negative	
12	RxOIN1+	+LVDS Differential Data (Odd G1-G5,B0-B1)	Positive	
13	VSS	Ground		
14	RxOIN2-	-LVDS Differential Data (Odd B2-B5,HS,VS,DE)	Negative	
15	RxOIN2+	+LVDS Differential Data (Odd B2-B5,HS,VS,DE)	Positive	
16	VSS	Ground		
17	RxOCKIN-	-LVDS Odd Differential CLK	Negative	
18	RxOCKIN+	+LVDS Odd Differential CLK	Positive	
19	VSS	Ground		
20	NC	No Connect		
21	NC	No Connect		
22	NC	No Connect		
23	NC	No Connect		
24	NC	No Connect		
25	NC	No Connect		
26	NC	No Connect		
27	NC	No Connect		
28	NC	No Connect		
29	NC	No Connect		
30	NC	No Connect		

Samsung Secret

No.	Symbol	Function	Polarity	Remarks
31	VLED_GND	LED Ground		
32	VLED_GND	LED Ground		
33	VLED_GND	LED Ground		
34	NC	No Connect		
35	S_PWMIN	System PWM signal Input		
36	BL_ON	LED enable pin (+3V input, +5V tolerance)		
37	NC	No Connect		
38	VLED	LED Power Supply 7V-20V		
39	VLED	LED Power Supply 7V-20V		
40	VLED	LED Power Supply 7V-20V		

5.2 LVDS Interface : Transmitter DS90CF363 or Compatible

Pin No.	Name	RGB Signal	Pin No.	Name	RGB Signal
51	TxIN0	R0	14	TxIN14	G5
52	TxIN1	R1	15	TxIN15	B0
54	TxIN2	R2	19	TxIN18	B1
55	TxIN3	R3	20	TxIN19	B2
56	TxIN4	R4	22	TxIN20	B3
3	TxIN6	R5	23	TxIN21	B4
4	TxIN7	G0	24	TxIN22	B5
6	TxIN8	G1	27	TxIN24	Hsync
7	TxIN9	G2	28	TxIN25	Vsync
11	TxIN12	G3	30	TxIN26	DE
12	TxIN13	G4	31	TxCLKIN	Clock

LVDS INTERFACE

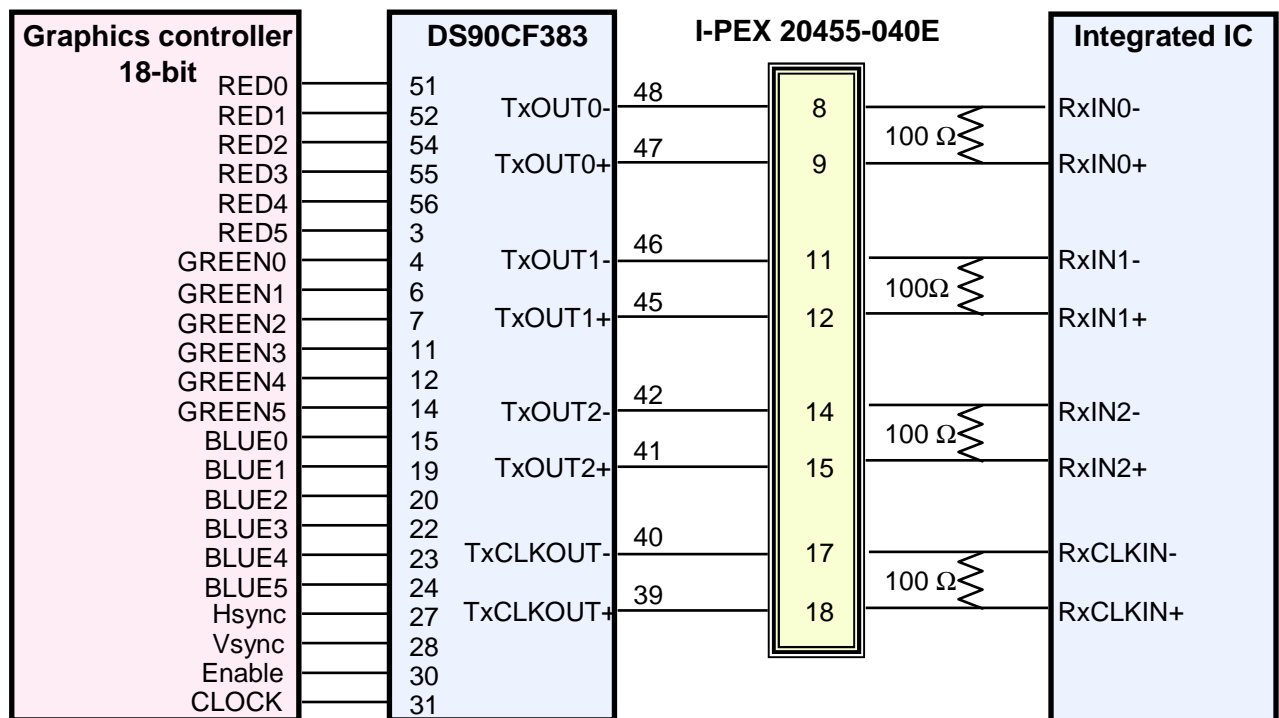

Note : The LCD Module uses a 100ohm resistor between positive and negative lines of each receiver input.

Samsung Secret

5.3 Timing Diagrams of LVDS For Transmission

LVDS Receiver : Integrated T-CON

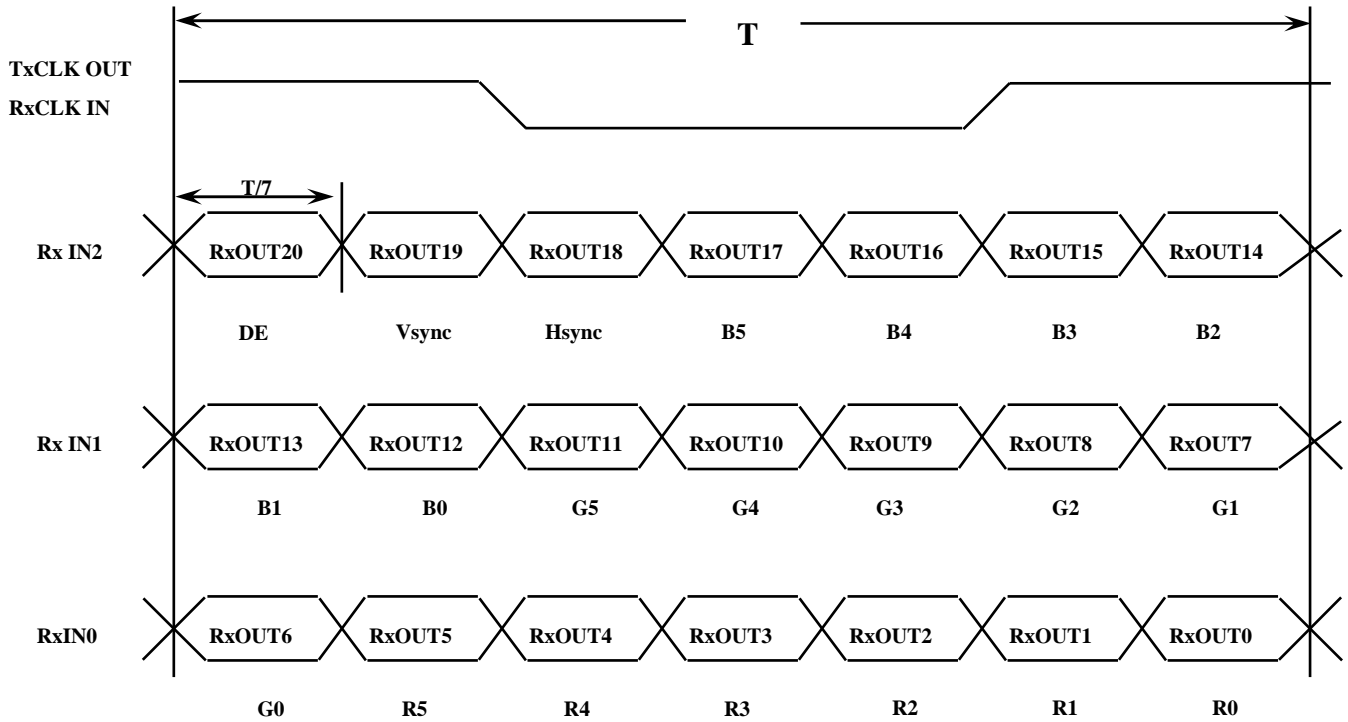

Samsung Secret

5.4 Input Signals, Basic Display Colors and Gray Scale of Each Color

Color	Display	Data Signal																	Gray Scale Level	
		Red					Green					Blue								
		R0	R1	R2	R3	R4	R5	G0	G1	G2	G3	G4	G5	B0	B1	B2	B3	45		B5
Basic Colors	Black	0	0	0	0	0	0	0	0	0	0	0	0	0	0	0	0	0	0	-
	Blue	0	0	0	0	0	0	0	0	0	0	0	0	1	1	1	1	1	1	-
	Green	0	0	0	0	0	0	1	1	1	1	1	1	0	0	0	0	0	0	-
	Cyan	0	0	0	0	0	0	1	1	1	1	1	1	1	1	1	1	1	1	-
	Red	1	1	1	1	1	1	0	0	0	0	0	0	0	0	0	0	0	0	-
	Magenta	1	1	1	1	1	1	0	0	0	0	0	0	1	1	1	1	1	1	-
	Yellow	1	1	1	1	1	1	1	1	1	1	1	1	0	0	0	0	0	0	-
	White	1	1	1	1	1	1	1	1	1	1	1	1	1	1	1	1	1	1	-
Gray Scale Of Red	Black	0	0	0	0	0	0	0	0	0	0	0	0	0	0	0	0	0	R0	
	Dark	1	0	0	0	0	0	0	0	0	0	0	0	0	0	0	0	0	R1	
	↑	0	1	0	0	0	0	0	0	0	0	0	0	0	0	0	0	0	R2	
	:	:	:	:	:	:	:	:	:	:	:	:	:	:	:	:	:	:	R3-R60	
	:	:	:	:	:	:	:	:	:	:	:	:	:	:	:	:	:	:		
	↓	1	0	1	1	1	1	0	0	0	0	0	0	0	0	0	0	0	R61	
	Light	0	1	1	1	1	1	0	0	0	0	0	0	0	0	0	0	0	R62	
	Red	1	1	1	1	1	1	0	0	0	0	0	0	0	0	0	0	0	R63	
Gray Scale Of Green	Black	0	0	0	0	0	0	0	0	0	0	0	0	0	0	0	0	0	G0	
	Dark	0	0	0	0	0	0	1	0	0	0	0	0	0	0	0	0	0	G1	
	↑	0	0	0	0	0	0	0	1	0	0	0	0	0	0	0	0	0	G2	
	:	:	:	:	:	:	:	:	:	:	:	:	:	:	:	:	:	:	G3-G60	
	:	:	:	:	:	:	:	:	:	:	:	:	:	:	:	:	:	:		
	↓	0	0	0	0	0	0	1	0	1	1	1	1	0	0	0	0	0	G61	
	Light	0	0	0	0	0	0	0	1	1	1	1	1	0	0	0	0	0	G62	
	Green	0	0	0	0	0	0	1	1	1	1	1	1	0	0	0	0	0	G63	
Gray Scale Of Blue	Black	0	0	0	0	0	0	0	0	0	0	0	0	0	0	0	0	0	B0	
	Dark	0	0	0	0	0	0	0	0	0	0	0	0	1	0	0	0	0	B1	
	↑	0	0	0	0	0	0	0	0	0	0	0	0	0	1	0	0	0	B2	
	:	:	:	:	:	:	:	:	:	:	:	:	:	:	:	:	:	:	B3-B60	
	:	:	:	:	:	:	:	:	:	:	:	:	:	:	:	:	:	:		
	↓	0	0	0	0	0	0	0	0	0	0	0	0	1	0	1	1	1	B61	
	Light	0	0	0	0	0	0	0	0	0	0	0	0	0	1	1	1	1	B62	
	Blue	0	0	0	0	0	0	0	0	0	0	0	0	1	1	1	1	1	B63	

Note 1) Definition of gray :

Rn: Red gray, Gn: Green gray, Bn: Blue gray (n=gray level)

Note 2) Input signal: 0 =Low level voltage, 1=High level voltage

Samsung Secret

5.5 Pixel Format in the display

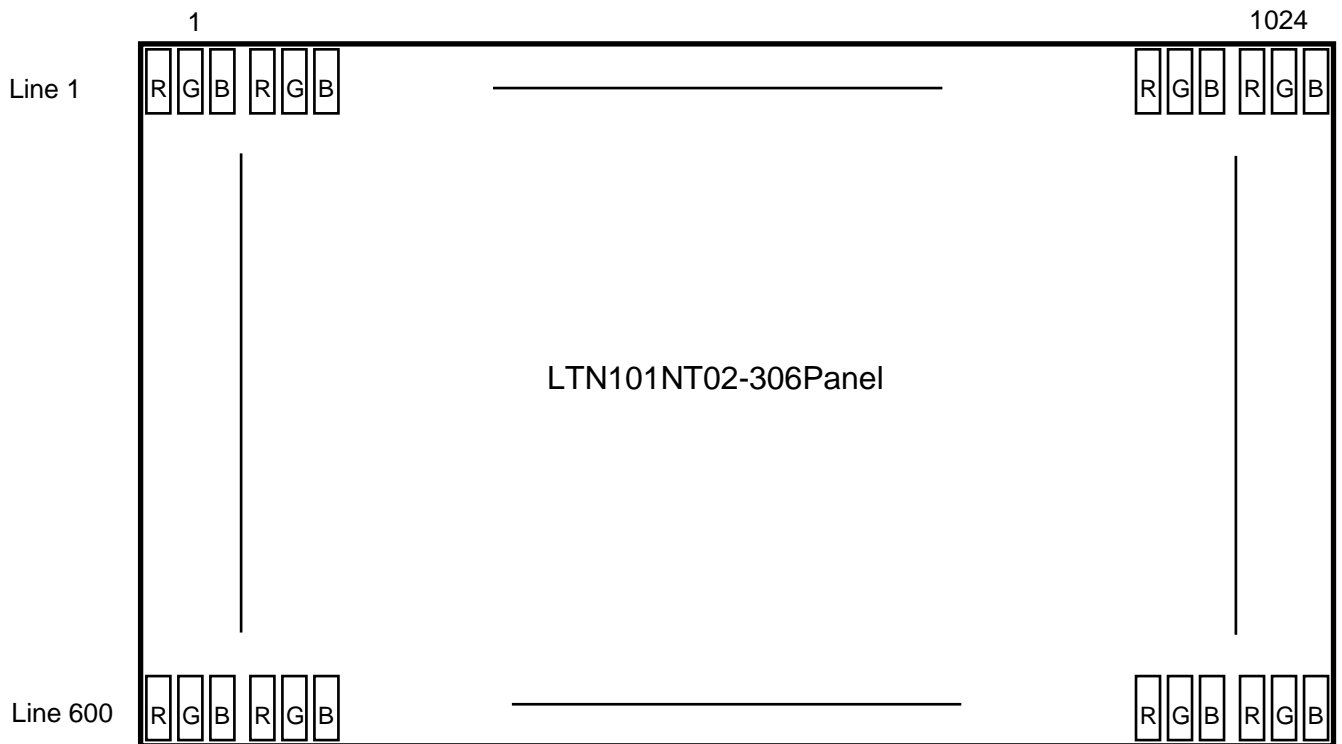

Samsung Secret

6. INTERFACE TIMING

6.1 Timing Parameters

Signal	Item	Symbol	Min.	Typ.	Max.	Unit	Note
Frame Frequency	Cycle	TV	-	686	-	Lines	
Vertical Active Display Term	Display Period	TVD	-	600	-	Lines	
One Line Scanning Time	Cycle	TH	-	1428	-	Clocks	
Horizontal Active Display Term	Display Period	THD	-	1024	-	Clocks	

6.2 Timing diagrams of interface signal

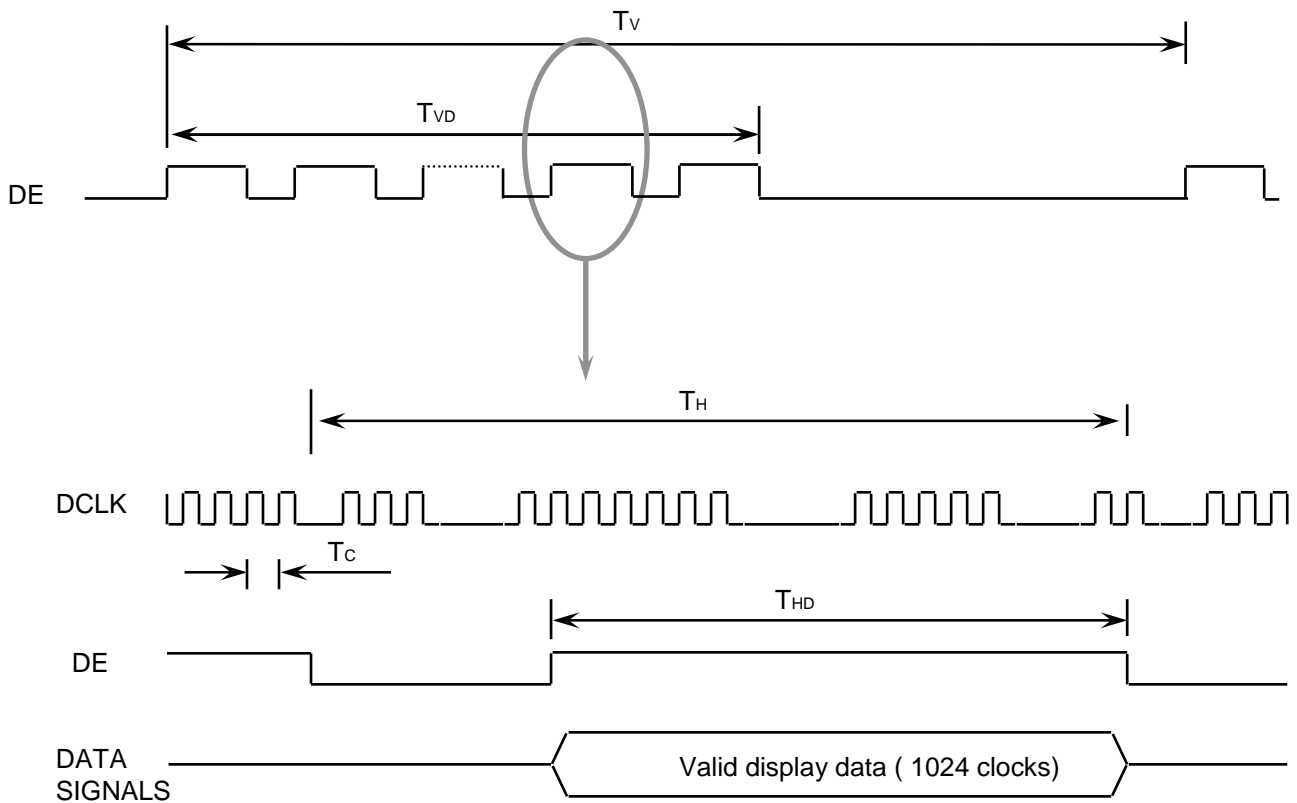

6.3 Power ON/OFF Sequence

: To prevent a latch-up or DC operation of the LCD module, the power on/off sequence should be as the diagram below.

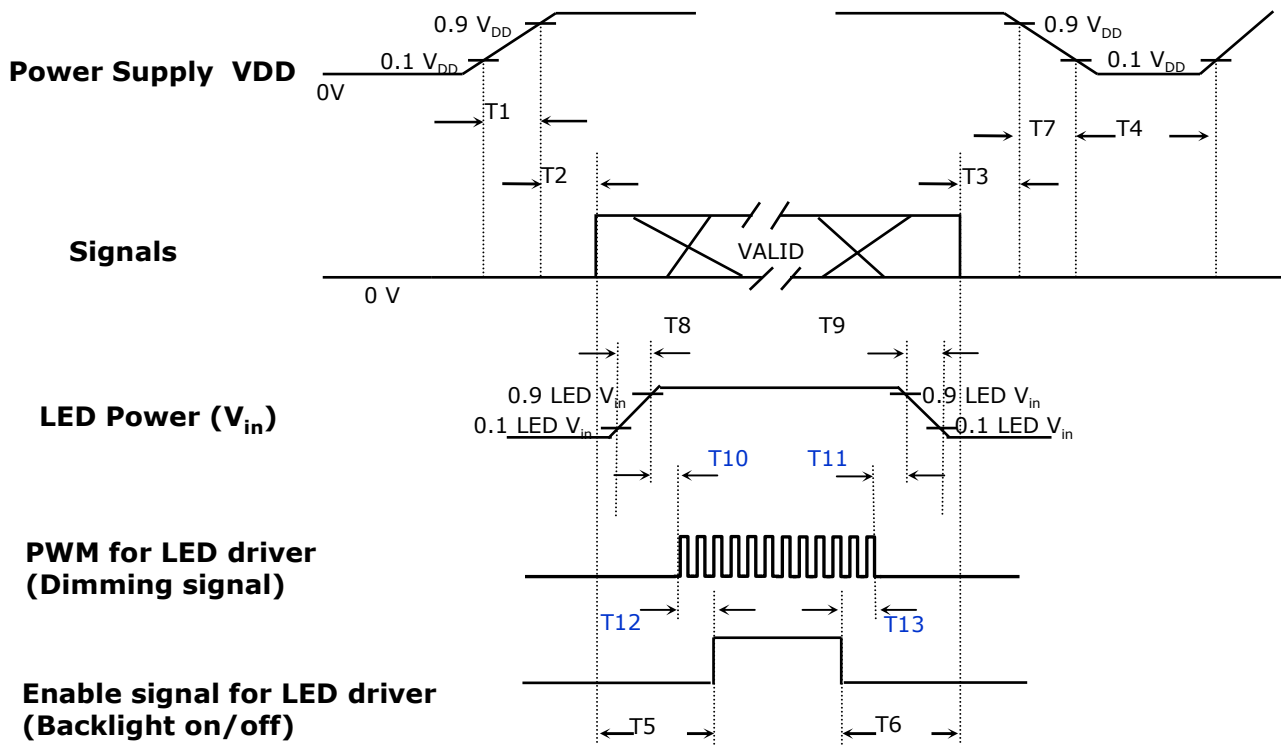

Power ON/OFF Sequence

Timing (ms)	Remarks
$0.5 < T1 \leq 10$	V _{DD} rising time from 10% to 90%
$0 < T2 \leq 50$	Delay from V _{DD} to valid data at power ON
$0 < T3 \leq 50$	Delay from valid data OFF to V _{DD} OFF at power Off
$500 \leq T4$	V _{DD} OFF time for Windows restart
$200 \leq T5$	Delay from valid data to B/L enable at power ON
$200 \leq T6$	Delay from valid data off to B/L disable at power Off
$0 < T7 \leq 10$	V _{DD} falling time from 90% to 10%
$0.5 < T8 \leq 10$	LED V _{in} rising time from 10% to 90%
$0.5 < T9 \leq 10$	LED V _{in} falling time from 90% to 10%
$0 \leq T10$	Delay from LED driver Vin rising time 90% to PWM ON
$0 \leq T11$	Delay from PWM Off to LED driver Vin falling time 10%, Must Keep rule
$0 \leq T12$	Delay from PWM ON to B/L Enable ON, Must Keep rule
$0 \leq T13$	Delay from B/L Enable Off to PWM Off

Power Sequence & Timing Parameters

Samsung Secret

7. Mechanical Outline Dimension

Refer to the next page

Samsung Secret

PRELIMINARY

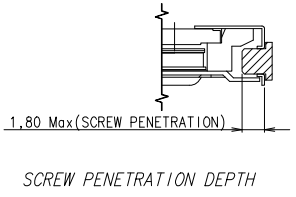
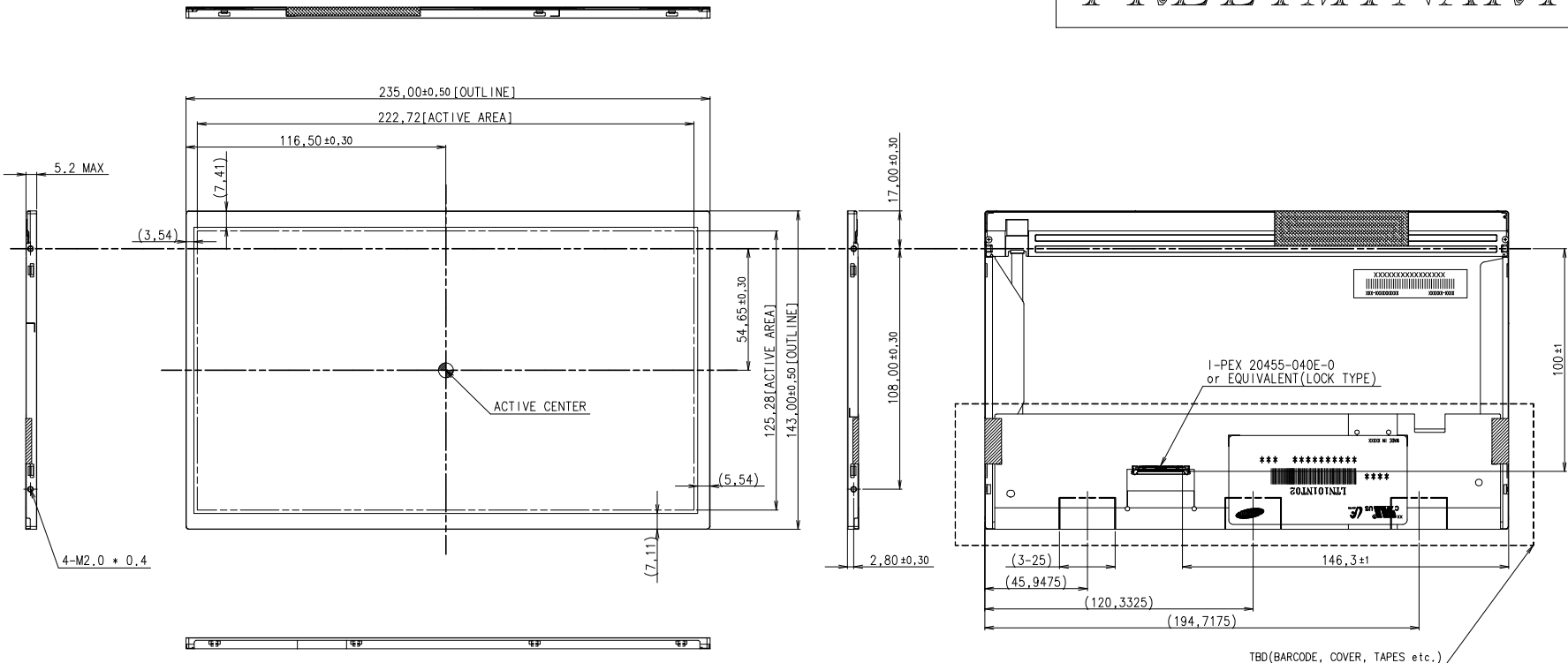

LTN101NT02-306
Samsung Confidential

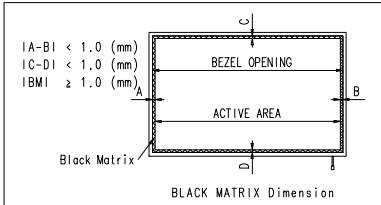

- * NOTE
- SIGNAL INTERFACE CONNECTOR TO BE SPECIFIED AS BELOW.
- MAKER : 1-PEX
- INPUT : 1-PEX 20455-040E-0 or EQUIVALENT (LOCK TYPE)
 - ALLOWED DEPTH OF USERHOLE SCREW INSERTION IS 1.8mm MAX.
 - CALIFERS MEASURING FORCE : 750 gf
 - USER HOLE TORQUE SPEC : 2.0 kgfcm Max (5TIMES)
 - WEIGHT SPEC : 200g Max
 - IN ORDER TO AVOID IC DAMAGE, IT IS NOT ALLOW THAT OVERLAPPING OF CABLES OR ANTENNAS, CAMERA, WLAN, WWAN OVER THESE COF LACATIONS

REV	DATE	DESCRIPTION OF REVISION	REASON	CHK'D BY
UNIT	mm	DRAWN BY DES'D BY CHK'D BY APP'D BY	MODEL NAME	LTN101NT02-306
SCALE	1:1	J.I.LEE	H.S.CHAN	PART/SHEET NAME
GENERAL TOLERANCE	±0.5	2009.10.14	2009.10.14	OUTLINE DIMENSION SHEET 1/1
SAMSUNG ELECTRONICS		SPEC. NO.	CODE NO.	VER. 000

8. PACKING

1. CARTON (Internal Package)

- (1) Packing Form
Styrofoam cushion box as shock absorber

(2) Packing Method

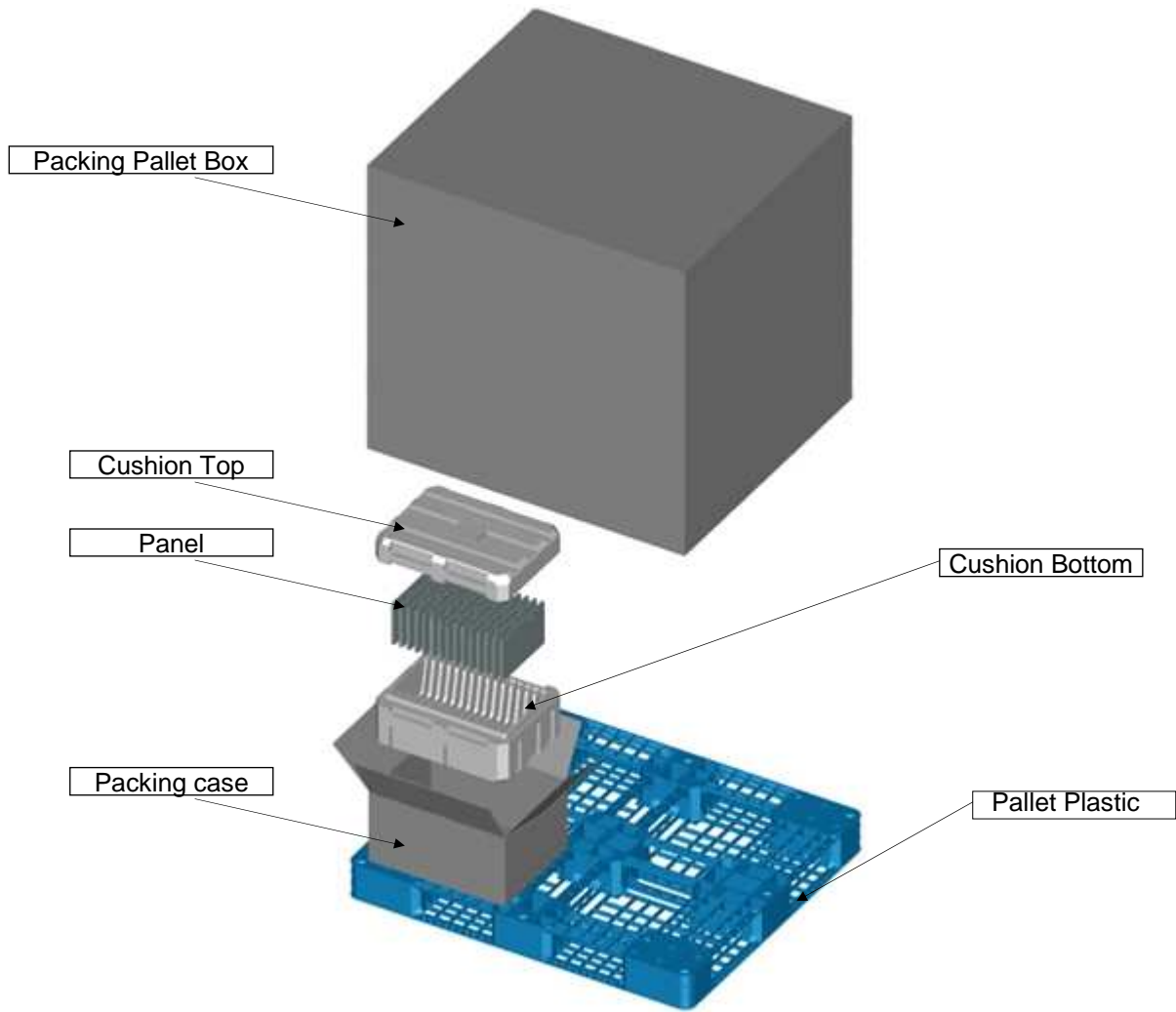

PACKING CASE

- Note 1) Total Weight : Approximately (7) kg
- 2) Acceptance number of piling : (30) sets
- 3) Carton size : 450(W) × 340(D) × 230(H)

Samsung Secret

Preliminary

(3)Packing Material

No	Part name	Quantity
1	Static electric protective sack	30
2	Packing case (Inner box)	1 set
3	Pictorial marking	2 pcs
4	Silicagel (500 x 1)	1
5	Carton	1 set

9. MARKINGS & OTHERS

A nameplate bearing followed by is affixed to a shipped product at the specified location on each product.

(1)Parts number : LTN101NT02

(2)Revision code : 3 letters

(3)Lot number : X X X X XXX XX X **306**

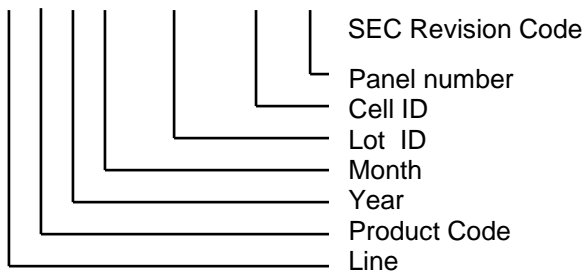

(5) Nameplate Indication

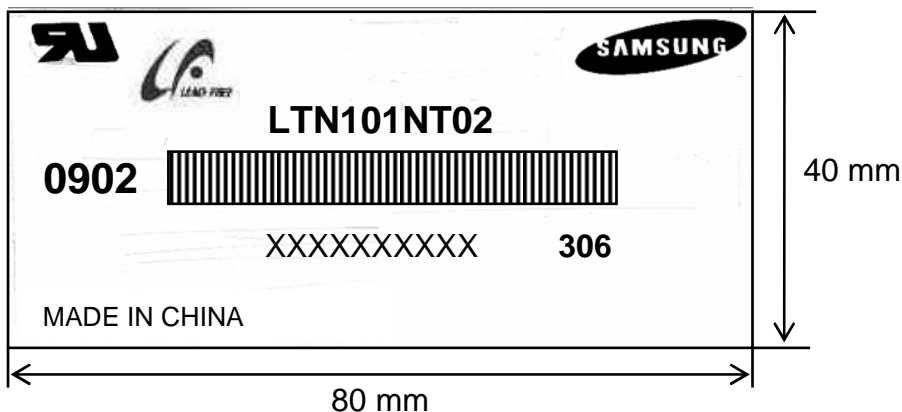

Parts name : LTN101NT02
 Lot number : XXXXXXXXXXXX
 Inspected work week : 0902(2009 year, 2nd week)

Samsung Secret

(6) Packing small box attach

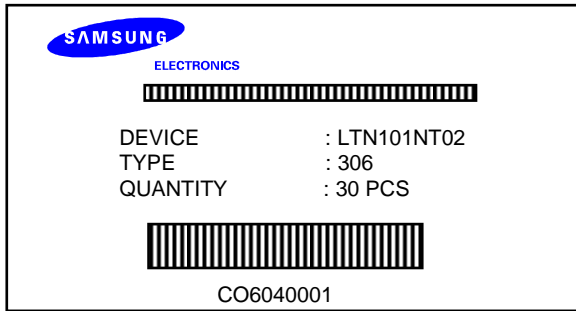

Samsung Secret

10. GENERAL PRECAUTIONS

1. Handling

- (a) When the module is assembled, It should be attached to the system firmly using every mounting holes. Be careful not to twist and bend the modules.
- (b) Refrain from strong mechanical shock and / or any force to the module. In addition to damage, this may cause improper operation or damage to the module.
- (c) Note that polarizers are very fragile and could be easily damaged. Do not press or scratch the surface harder than a HB pencil lead.
- (d) Wipe off water droplets or oil immediately. If you leave the droplets for a long time, Staining and discoloration may occur.
- (e) If the surface of the polarizer is dirty, clean it using some absorbent cotton or soft cloth.
- (f) The desirable cleaners are water, IPA (Isopropyl Alcohol) or Hexane. Do not use Ketone type materials(ex. Acetone), Ethyl alcohol, Toluene, Ethyl acid or Methyl chloride. It might permanent damage to the polarizer due to chemical reaction.
- (g) If the liquid crystal material leaks from the panel, it should be kept away from the eyes or mouth. In case of contact with hands, legs or clothes, it must be washed away thoroughly with soap.
- (h) Protect the module from static, it may cause damage to the C-MOS Gate Array IC.
- (i) Use fingerstalls with soft gloves in order to keep display clean during the incoming inspection and assembly process.
- (j) Do not disassemble the module.
- (k) Do not pull or fold the lamp wire.
- (l) Do not adjust the variable resistor which is located on the back side.
- (m) Protection film for polarizer on the module shall be slowly peeled off just before use so that the electrostatic charge can be minimized.
- (n) Pins of I/F connector shall not be touched directly with bare hands.

2. STORAGE

- (a) Do not leave the module in high temperature, and high humidity for a long time. It is highly recommended to store the module with temperature from 0 to 35 °C and relative humidity of less than 70%.
- (b) Do not store the TFT-LCD module in direct sunlight.
- (c) The module shall be stored in a dark place. It is prohibited to apply sunlight or fluorescent light during the store.

3. OPERATION

- (a) Do not connect,disconnect the module in the “ Power On” condition.
- (b) Power supply should always be turned on/off by following item 6.3 “ Power on/off sequence “.
- (c) Module has high frequency circuits. Sufficient suppression to the electromagnetic interference shall be done by system manufacturers. Grounding and shielding methods may be important to minimize the interference.
- (d) The standard limited warranty is only applicable when the module is used for general notebook applications. If used for purposes other than as specified, SEC is not to be held reliable for the defective operations. It is strongly recommended to contact SEC to find out fitness for a particular purpose.

4. OTHERS

- (a) Ultra-violet ray filter is necessary for outdoor operation.
- (b) Avoid condensation of water. It may result in improper operation or disconnection of electrode.
- (c) Do not exceed the absolute maximum rating value. (the supply voltage variation, input voltage variation, variation in part contents and environmental temperature, so on) Otherwise the module may be damaged.
- (d) If the module displays the same pattern continuously for a long period of time, it can be the situation when the image “sticks” to the screen.
- (e) This module has its circuitry PCB's on the rear side and should be handled carefully in order not to be stressed.