

mass integrated

global part distribution • product lifecycle partner
excess inventory management • value-ad service provider



Data sheet provided by Mass Integrated

massintegrated.com • displayalliance.com

Please call +1.978.465.6190
Email: sales@massintegrated.com



ISO 9001: 2008

Mass Integrated complies with all DMCA takedown notices. Please send a formal DMCA Takedown Notice to Mass Integrated Systems, Inc. • 18 Henry Graf Jr. Road, Unit 1 • Newburyport, MA 01950.

SAMSUNG

ELECTRONICS

preliminary



TO :

DATE : Nov.17 , 2009

SAMSUNG TFT-LCD

MODEL NO. : LTN121AT06-G01

NOTE : Extension code [-G01]
→ LTN121AT06-**G01**
Surface type [**Glare**]

Any Modification of Spec is not allowed without SEC' permission.

**Application engineering part, Mobile Division
Samsung Electronics Co., Ltd.**



CONTENTS

preliminary

Revision History	----- (3)
General Description	----- (4)
1. Absolute Maximum Ratings	----- (5)
1.1 Absolute Ratings of environment	
1.2 Electrical Absolute Ratings	
2. Optical Characteristics	----- (7)
3. Electrical Characteristics	----- (10)
3.1 TFT LCD Module	
3.2 Backlight Unit	
4. Block Diagram	----- (13)
4.1 TFT LCD Module	
5. Input Terminal Pin Assignment	----- (14)
5.1 Input Signal & Power	
5.2 LVDS Interface	
5.3 Timing Diagrams of LVDS For Transmitting	
5.4 Input Signals, Basic Display Colors and Gray Scale of Each Color.	
5.5 Pixel format	
6. Interface Timing	----- (20)
6.1 Timing Parameters	
6.2 Timing Diagrams of interface Signal	
6.3 Power ON/OFF Sequence	
7. Outline Dimension	----- (22)
8. Packing	----- (24)
9. Marking & Others	----- (25)
10. General Precautions	----- (27)
11. EDID	----- (29)

REVISION HISTORY

preliminary

Date	Revision No.	Page	Summary
Nov. 17, 2008	P00	All	The preliminary specification of LTN121AT06-G01 model was issued first.

GENERAL DESCRIPTION

DESCRIPTION

LTN121AT06 is a color active matrix TFT (Thin Film Transistor) liquid crystal display (LCD) that uses amorphous silicon TFT as switching devices. This model is composed of a TFT LCD panel, a driver circuit and a backlight unit. The resolution of a 12.1" contains 1280 x 800 pixels and can display up to 262,144 colors. 6 O'clock direction is the optimum viewing angle.

FEATURES

- High contrast ratio
- WXGA (1280 x 800 pixels) resolution
- Low power consumption
- Fast Response
- LED Back Light with embedded LED Driver
- DE (Data enable) only mode
- 3.3V LVDS Interface
- Onboard EEDID chip
- Green product (RoHS compliant)

APPLICATIONS

- Notebook PC
- If the usage of this product is not for PC application, but for others, please contact SEC

GENERAL INFORMATION

Item	Specification	Unit	Note
Display area	261.12(H) x 163.2(V) (12.1" wide diagonal)	mm	
Driver element	a-Si TFT active matrix		
Display colors	262,144		
Number of pixel	1280 x 800	pixel	
Pixel arrangement	RGB vertical stripe		
Pixel pitch	0.204(H) x 0.204(V) (TYP.)	mm	
Display Mode	Normally white		
Surface treatment	Haze 0, Hard-Coating 3H		

Mechanical Information

Item		Min.	Typ.	Max.	Unit	Note
Module size	Horizontal (H)	275.3	275.8	276.3	mm	
	Vertical (V)	177.6	178.1	178.6	mm	
	Depth (D)	-	5.2	5.5	mm	(1)
Weight		-	278	295	g	

Note (1) Measurement condition of outline dimension
 . Equipment : Bernier Calipers
 . Push Force : 500g · f (minimum)

1. ABSOLUTE MAXIMUM RATINGS

1.1 ENVIRONMENTAL ABSOLUTE RATINGS

Item	Symbol	Min.	Max.	Unit	Note
Storage temperate	TSTG	-20	60	°C	(1)
Operating temperate (Temperature of glass surface)	TOPR	0	50	°C	(1)
Shock (non-operating)	Snop	-	240	G	(2),(4)
Vibration (non-operating)	Vnop	-	2.41	G	(3),(4)

Note (1) Temperature and relative humidity range are shown in the figure below.
 95 % RH Max. ($40\text{ °C} \geq T_a$)
 Maximum wet - bulb temperature at 39 °C or less. ($T_a > 40\text{ °C}$) No condensation

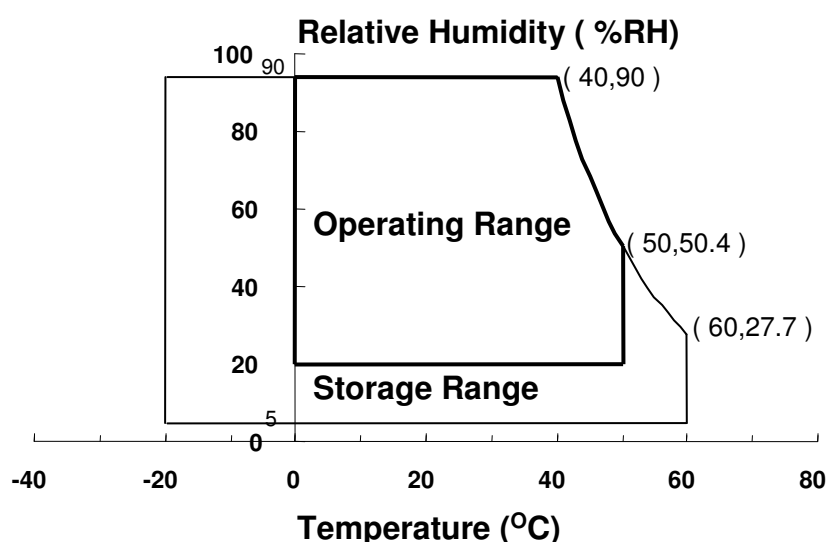

- (2) 2ms, half sine wave, one time for $\pm X, \pm Y, \pm Z$.
 (3) 5 - 500 Hz, random vibration, 30min for X, Y, Z.
 (4) At testing Vibration and Shock, the fixture in holding the Module to be tested have to be hard and rigid enough so that the Module would not be twisted or bent by the fixture.

1.2 ELECTRICAL ABSOLUTE RATINGS

(1) TFT LCD MODULE

 $V_{DD} = 3.3V, V_{SS} = GND = 0V$

Item	Symbol	Min.	Max.	Unit	Note
Power Supply Voltage	V_{DD}	$V_{DD} - 0.3$	$V_{DD} + 0.3$	V	(1)
Logic Input Voltage	V_{IN}	$V_{DD} - 0.3$	$V_{DD} + 0.3$	V	(1)

Note (1) Within T_a (25 ± 2 °C)

2. OPTICAL CHARACTERISTICS

The following items are measured under stable conditions. The optical characteristics should be measured in a dark room or equivalent state with the methods shown in Note (5).
Measuring equipment : TOPCON SR-3

* Ta = 25 ± 2 °C, V_{DD}=3.3V, fv= 60Hz, f_{DCLK} = 69.3MHz, IF = 19.0 mA

Item		Symbol	Condition	Min.	Typ.	Max	Unit	Note
Contrast Ratio (5 Points)		CR	Normal Viewing Angle $\phi = 0$ $\theta = 0$	400	500	-	-	(1), (2), (5)
Response Time at Ta (Rising + Falling)		T _{RT}		-	25	35	msec	(1), (3)
Average Luminance of White (5 Points)		Y _{L,AVE}		170	200	-	cd/m ²	IF=19.0mA (1), (4)
Color Chromaticity (CIE)	Red	R _X		0.555	0.585	0.615	-	(1), (5) SR-3
		R _Y		0.330	0.360	0.390		
	Green	G _X		0.345	0.375	0.405		
		G _Y		0.535	0.565	0.595		
	Blue	B _X		0.125	0.155	0.185		
		B _Y	0.070	0.100	0.130			
	White	W _X	0.283	0.313	0.343			
		W _Y	0.299	0.329	0.359			
Viewing Angle	Hor.	θ_L	CR ≥ 10 At center	30	45	Degrees	(1), (5) SR-3	
		θ_R		30	45			
	Ver.	ϕ_H		10	20			
		ϕ_L		20	30			
13 Points White Variation		δ_L	-	1.4	1.6	-	(6)	

Note 1) Definition of Viewing Angle : Viewing angle range($10 \leq C/R$)

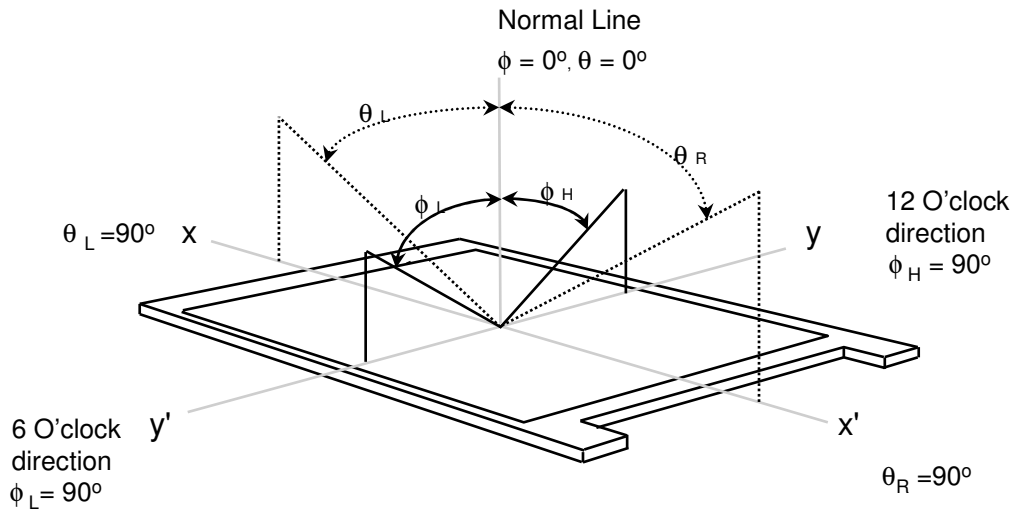

Note 2) Definition of Contrast Ratio (CR) : Ratio of gray max (Gmax) ,gray min (Gmin) at 5 points(4, 5, 7, 9, 10)

$$CR = \frac{CR(4) + CR(5) + CR(7) + CR(9) + CR(10)}{5}$$

Points : (4) , (5) , (7) , (9) , (10) at the figure of Note (6).

Note 3) Definition of Response time :

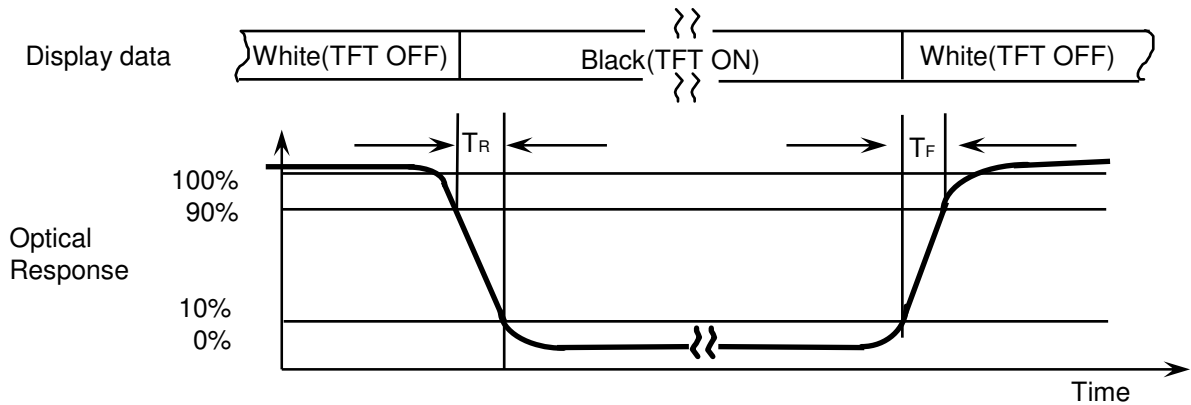

Note 4) Definition of Average Luminance of White : measure the luminance of white at 5 points.

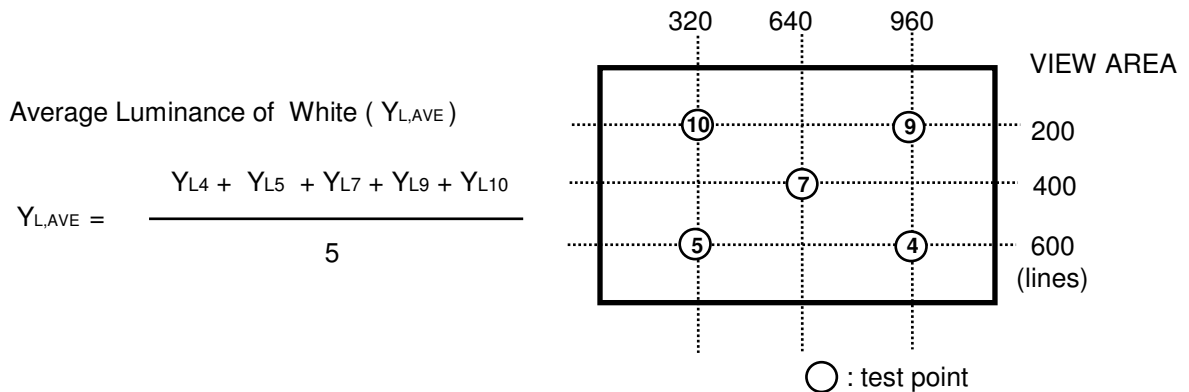

Average Luminance of White ($Y_{L,AVE}$)

$$Y_{L,AVE} = \frac{Y_{L4} + Y_{L5} + Y_{L7} + Y_{L9} + Y_{L10}}{5}$$

Note 5) After stabilizing and leaving the panel alone at a given temperature for 30 min , the measurement should be executed. Measurement should be executed in a stable, windless, and dark room. 30 min after lighting the backlight. This should be measured in the center of screen.

IF current : 19.0mA

Environment condition : $T_a = 25 \pm 2 \text{ }^\circ\text{C}$

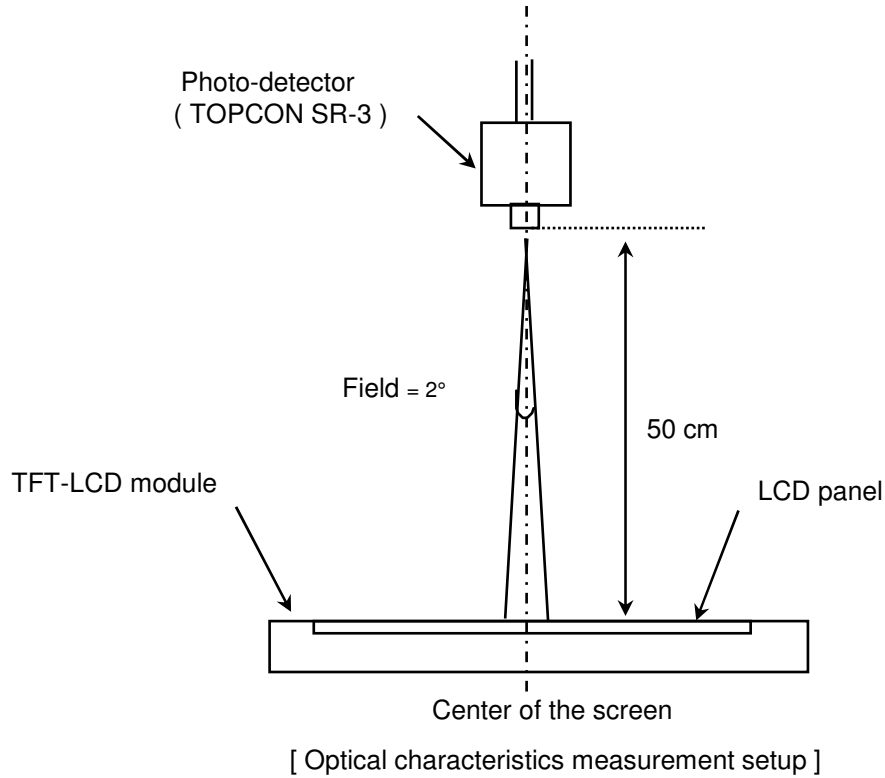

Note 6) Definition of 13 points white variation (δL), CR variation(C_{VER}) [① ~ ⑬]

$$\delta L = \frac{\text{Maximum luminance of 13 points}}{\text{Minimum luminance of 13 points}}$$

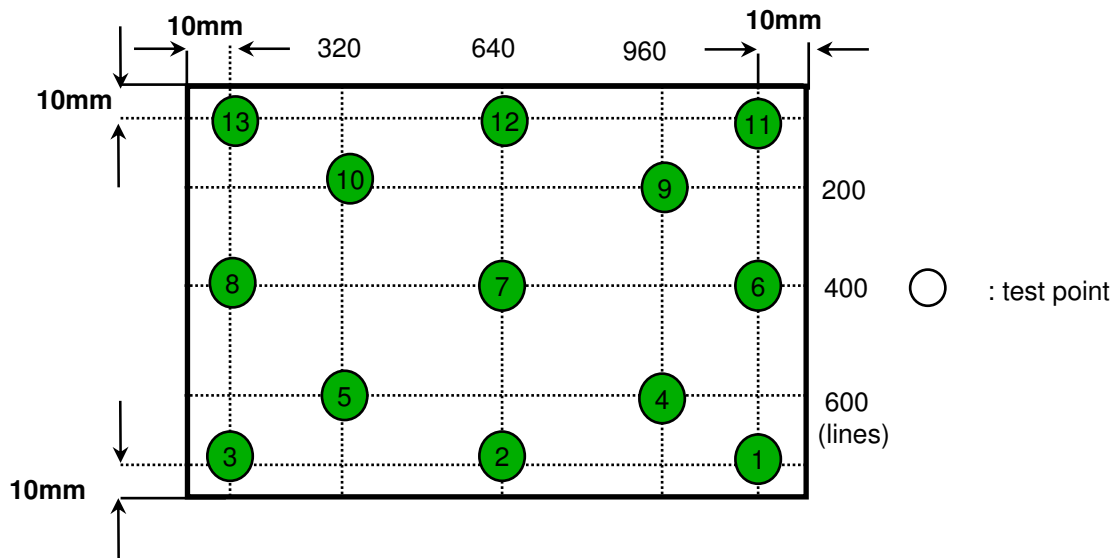

3. ELECTRICAL CHARACTERISTICS

3.1 TFT LCD MODULE

 $T_a = 25 \pm 2^\circ\text{C}$

Item	Symbol	Min.	Typ.	Max.	Unit	Note	
Voltage of Power Supply	V_{DD}	3.0	3.3	3.6	V		
Differential Input Voltage for LVDS Receiver Threshold	High	V_{IH}	-	-	+100	mV	$V_{CM} = +1.2V$
	Low	V_{IL}	-100	-	-	mV	
Vsync Frequency	f_V	-	60	-	Hz		
Hsync Frequency	f_H	-	51.2	-	KHz		
Main Frequency	f_{DCLK}	67.2	69.3	70.6	MHz		
Rush Current	I_{RUSH}	-	-	1.5	A	(4)	
Current of Power Supply	White	I_{DD}	-	220	-	mA	(2),(3)*a
	Mosaic		-	240	-	mA	(2),(3)*b
	V. stripe		-	280	320	mA	(2),(3)*c

Note (1) Display data pins and timing signal pins should be connected. (GND = 0V)

(2) $f_V = 60\text{Hz}$, $f_{DCLK} = 69.3\text{MHz}$, $V_{DD} = 3.3V$, DC Current.

(3) Power dissipation pattern

*a) White Pattern

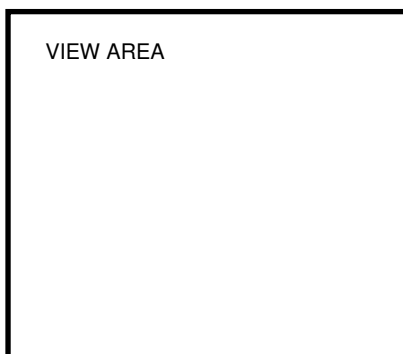

*b) Mosaic Pattern

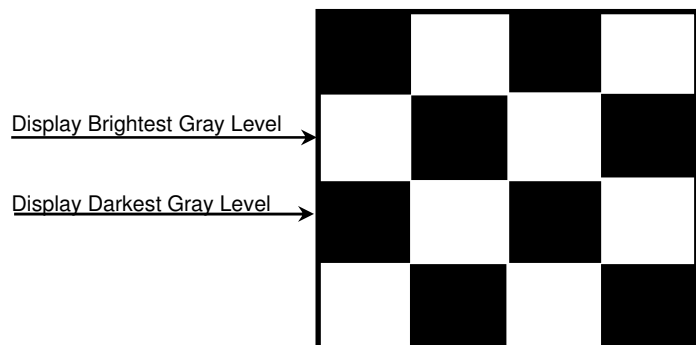

*c) 1dot Vertical stripe pattern

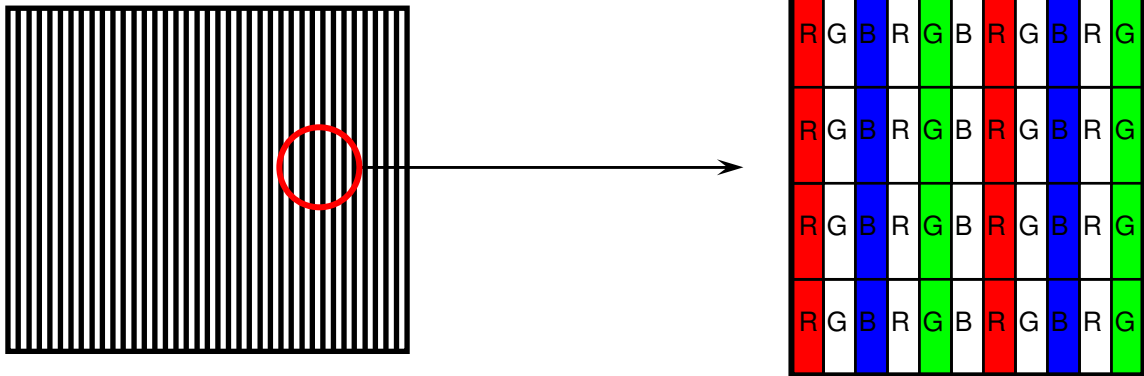

4) Rush current measurement condition

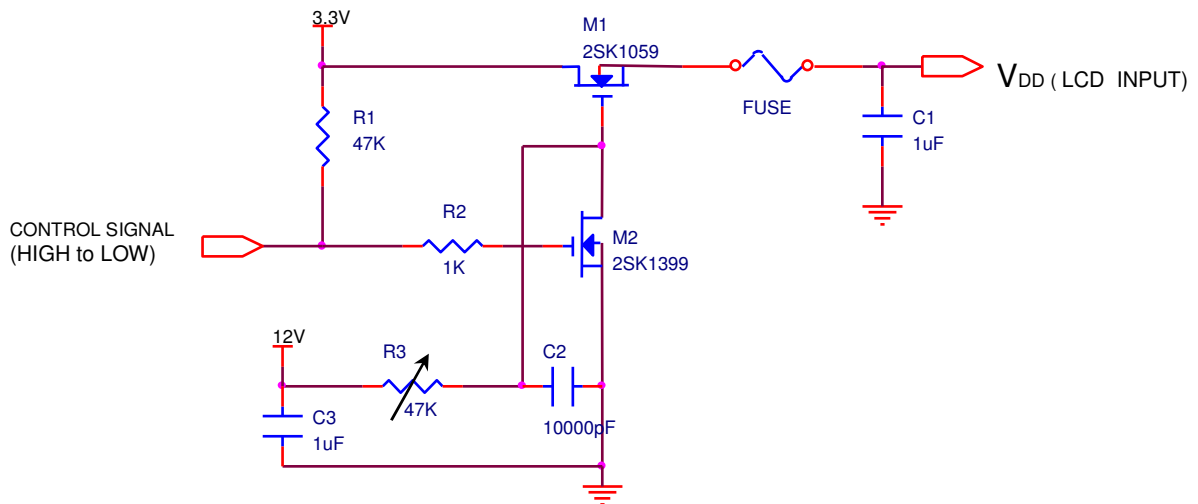

V_{DD} rising time is 470us

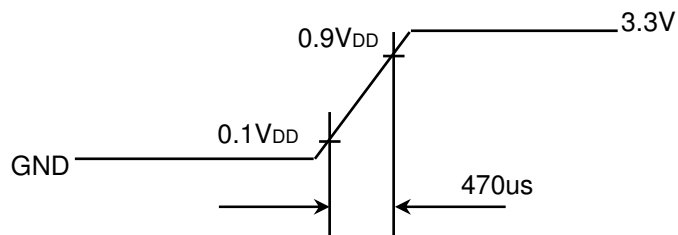

3.2 BACK-LIGHT UNIT

Ta= 25 ± 2 °C

Item	Symbol	Min.	Typ.	Max.	Unit	Note
LED Forward Current	IF	-	19	-	mA	
LED Forward Voltage	VF	-	3.2	-	V	
LED Array Voltage	VP	-	19.2	-	V	VF X 6 LEDs
Power Consumption	P	-	2.19	-	W	IF X VF X 36LEDs
Operating Life Time	Hr	12,000	-	-	Hour	(1)
Input Voltage	V _{in}	6	12	20	V	
External PWM Dimming Control Frequency (BLIM)	F _{BLIM}	0.2	-	20	kHz	V _{in} =7~20V, BLIM=PWM 0V~3.3V
Input Power	P _{in}	-	2.6	2.8	W	
Operating Frequency	F _o	0.2	0.6	1.0	MHz	
EN, Turn-On Level Threshold	BL_Enable	-	-	1.6	V	(2)
EN, Turn-Off Level Threshold	BL_Enable	0.8	-	-	V	(2)

Note - Test Equipment : Fluke 45

Note (1) Life time (Hr) of LEDs can be defined as the time in which it continues to operate under the condition Ta= 25 ± 2 °C and IF = 19.0 mArms until one of the following event occurs.

- When the brightness becomes 50% or lower than the original.

(2) Enable Input. When low, the device is turned off. The pin goes low when a fault condition is defect.

1) LED Time Sequence

. The proper startup sequence is DIM→VIN→EN, or VIN→DIM →EN.

If the dimming signal is applied after the EN pin, the device will not perform the soft start again, in fact it will start switching with the maximum current limit in order to recover the output voltage.

LED Time Sequence

DIM→VIN→EN, or VIN→DIM →EN.

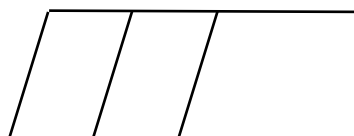

4. BLOCK DIAGRAM

4.1 TFT LCD Module

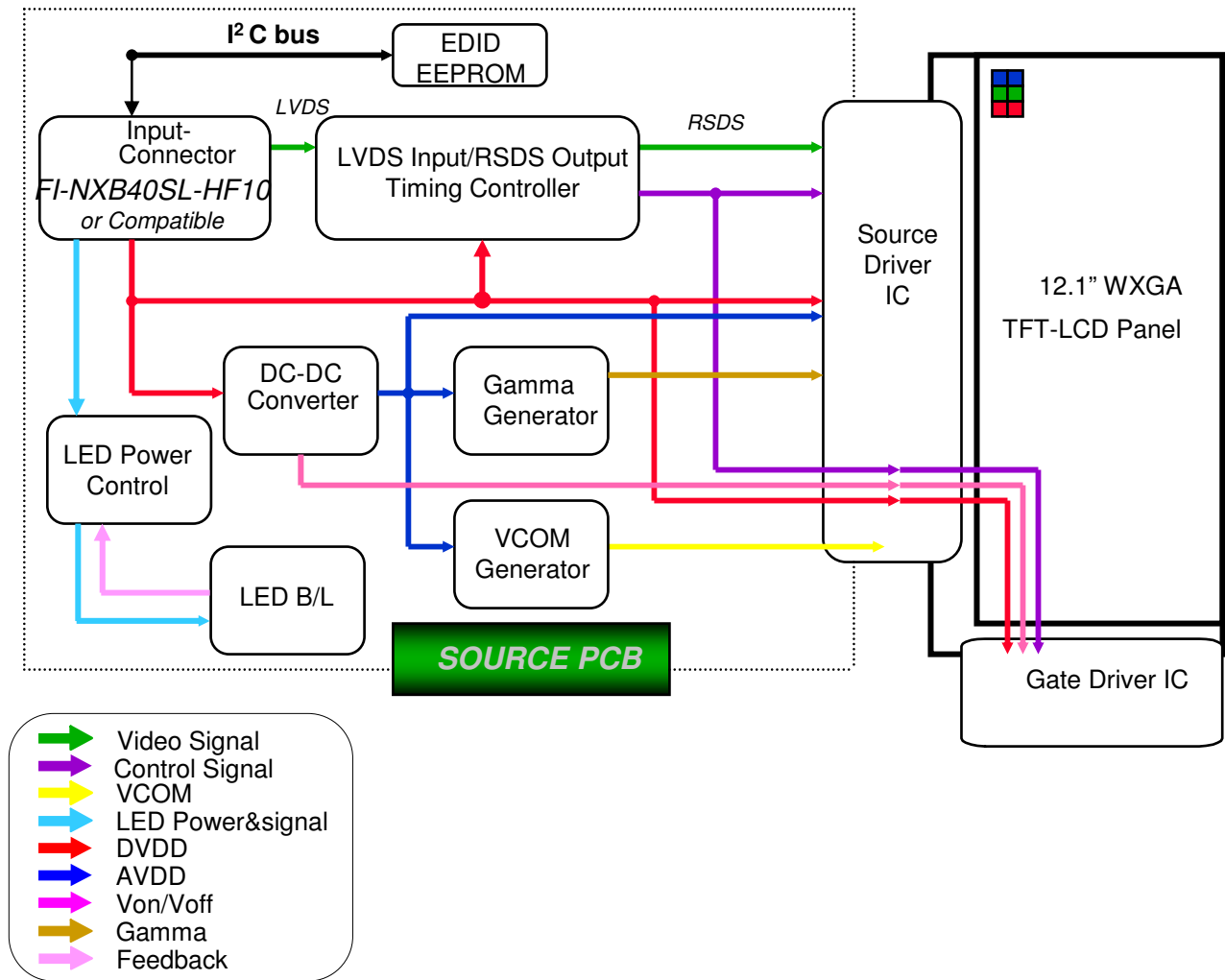

5. INPUT TERMINAL PIN ASSIGNMENT

5.1. Input Signal & Power (LVDS, Connector : FI-NXB40SL-HF10 by JAE or equivalent)

No.	Symbol	Function	Polarity	Remarks
1	NC	No Connection		
2	AVDD	Power Supply 3.3V (typical)		
3	AVDD	Power Supply 3.3V (typical)		
4	DVDD	DDC 3.3V power		
5	NC	No Connection		
6	SCL	DDC Clock		
7	SDA	DDC data		
8	RIN0-	LVDS differential data input (R0-R5, G0)	Negative	
9	RIN0+	LVDS differential data input (R0-R5, G0)	Positive	
10	GND	Ground		
11	RIN1-	LVDS differential data input (G1-G5, B0-B1)	Negative	
12	RIN1+	LVDS differential data input (G1-G5, B0-B1)	Positive	
13	GND	Ground		
14	RIN2-	LVDS differential data input (B2-B5, HS, VS, DE)	Negative	
15	RIN2+	LVDS differential data input (B2-B5, HS, VS, DE)	Positive	
16	GND	Ground		
17	CLK-	LVDS differential clock input	Negative	
18	CLK+	LVDS differential clock input	Positive	
19	GND	Ground		
20	NC	No Connection		
21	NC	No Connection		
22	GND	Ground		
23	NC	No Connection		
24	NC	No Connection		
25	GND	Ground		
26	NC	No Connection		
27	NC	No Connection		
28	GND	Ground		
29	NC	No Connection		
30	NC	No Connection		

No.	Symbol	Function	Polarity	Remarks
31	VBL-	LED Power return		
32	VBL-	LED Power return		
33	VBL-	LED Power return		
34	NC	No Connection		
35	VBL+	6V – 20V LED power		
36	VBL+	6V – 20V LED power		
37	VBL+	6V – 20V LED power		
38	BLIM	PWM for luminance control (200~1KHz, 3.3V)		
39	BL_Enable	BL On/Off (On: 2.0~3.3V, Off: 0~0.5V)		
40	NC	No Connection		

5.2 LVDS Interface : Transmitter DS90CF363 or Compatible

Pin No.	Name	RGB Signal	Pin No.	Name	RGB Signal
51	TxIN0	R0	14	TxIN14	G5
52	TxIN1	R1	15	TxIN15	B0
54	TxIN2	R2	19	TxIN18	B1
55	TxIN3	R3	20	TxIN19	B2
56	TxIN4	R4	22	TxIN20	B3
3	TxIN6	R5	23	TxIN21	B4
4	TxIN7	G0	24	TxIN22	B5
6	TxIN8	G1	27	TxIN24	Hsync
7	TxIN9	G2	28	TxIN25	Vsync
11	TxIN12	G3	30	TxIN26	DE
12	TxIN13	G4	31	TxCLKIN	Clock

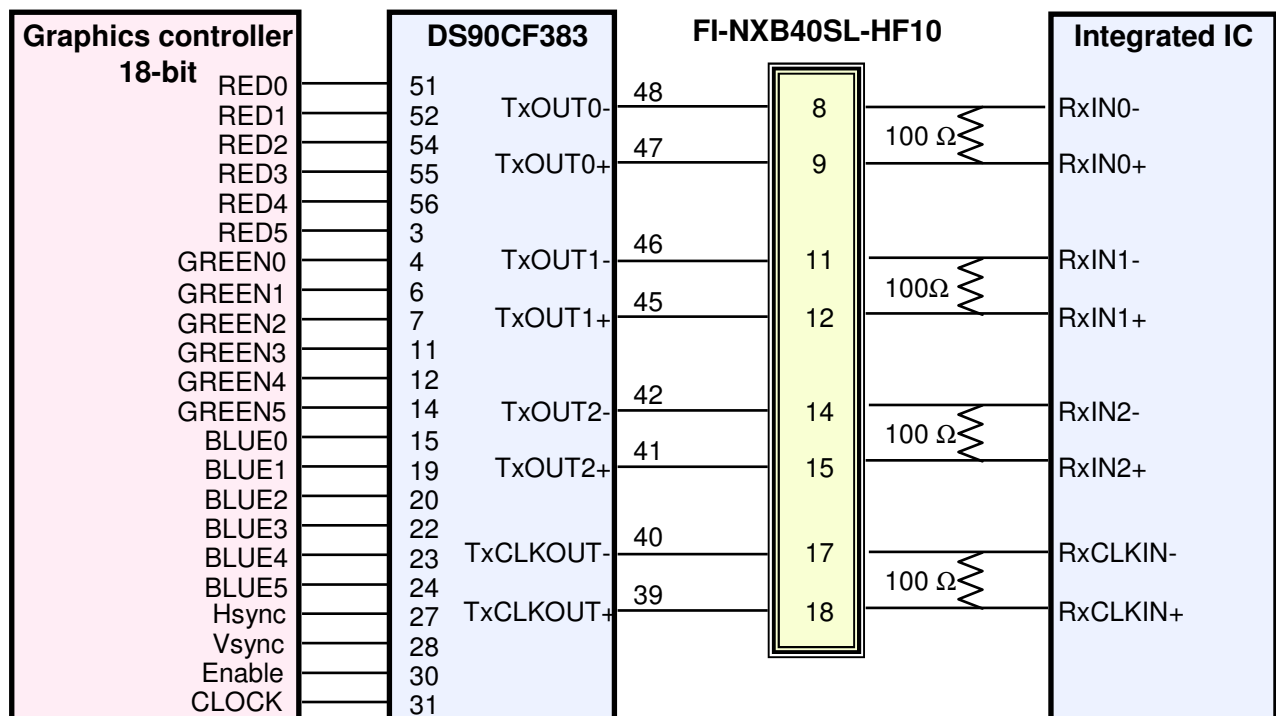
LVDS INTERFACE

Note : The LCD Module uses a 100ohm resistor between positive and negative lines of each receiver input.

5.3 Timing Diagrams of LVDS For Transmission

LVDS Receiver : Integrated T-CON

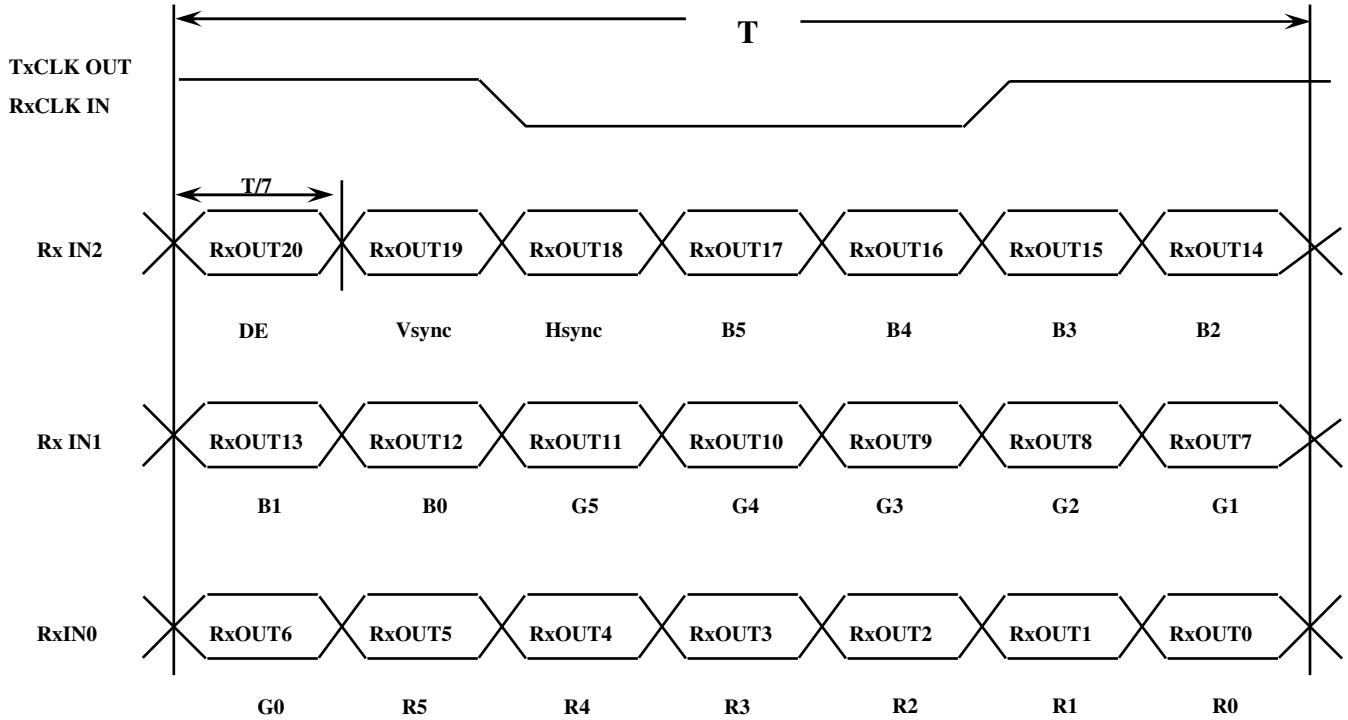

5.4 Input Signals, Basic Display Colors and Gray Scale of Each Color

Color	Display	Data Signal																Gray Scale Level	
		Red					Green					Blue							
		R0	R1	R2	R3	R4	R5	G0	G1	G2	G3	G4	G5	B0	B1	B2	B3		B4
Basic Colors	Black	0	0	0	0	0	0	0	0	0	0	0	0	0	0	0	0	0	-
	Blue	0	0	0	0	0	0	0	0	0	0	0	0	1	1	1	1	1	-
	Green	0	0	0	0	0	0	1	1	1	1	1	1	0	0	0	0	0	-
	Cyan	0	0	0	0	0	0	1	1	1	1	1	1	1	1	1	1	1	-
	Red	1	1	1	1	1	1	0	0	0	0	0	0	0	0	0	0	0	-
	Magenta	1	1	1	1	1	1	0	0	0	0	0	0	1	1	1	1	1	-
	Yellow	1	1	1	1	1	1	1	1	1	1	1	1	0	0	0	0	0	-
	White	1	1	1	1	1	1	1	1	1	1	1	1	1	1	1	1	1	-
Gray Scale Of Red	Black	0	0	0	0	0	0	0	0	0	0	0	0	0	0	0	0	0	R0
	Dark	1	0	0	0	0	0	0	0	0	0	0	0	0	0	0	0	0	R1
	↑	0	1	0	0	0	0	0	0	0	0	0	0	0	0	0	0	0	R3~R60
	:	:	:	:	:	:	:	:	:	:	:	:	:	:	:	:	:	:	
	:	:	:	:	:	:	:	:	:	:	:	:	:	:	:	:	:	:	
	↓	1	0	1	1	1	1	0	0	0	0	0	0	0	0	0	0	0	R61
	Light	0	1	1	1	1	1	0	0	0	0	0	0	0	0	0	0	0	R62
	Red	1	1	1	1	1	1	0	0	0	0	0	0	0	0	0	0	0	R63
Gray Scale Of Green	Black	0	0	0	0	0	0	0	0	0	0	0	0	0	0	0	0	0	G0
	Dark	0	0	0	0	0	0	1	0	0	0	0	0	0	0	0	0	0	G1
	↑	0	0	0	0	0	0	0	1	0	0	0	0	0	0	0	0	0	G3~G60
	:	:	:	:	:	:	:	:	:	:	:	:	:	:	:	:	:	:	
	:	:	:	:	:	:	:	:	:	:	:	:	:	:	:	:	:	:	
	↓	0	0	0	0	0	0	1	0	1	1	1	1	0	0	0	0	0	G61
	Light	0	0	0	0	0	0	0	1	1	1	1	1	0	0	0	0	0	G62
	Green	0	0	0	0	0	0	1	1	1	1	1	1	0	0	0	0	0	G63
Gray Scale Of Blue	Black	0	0	0	0	0	0	0	0	0	0	0	0	0	0	0	0	0	B0
	Dark	0	0	0	0	0	0	0	0	0	0	0	0	1	0	0	0	0	B1
	↑	0	0	0	0	0	0	0	0	0	0	0	0	0	1	0	0	0	B2
	:	:	:	:	:	:	:	:	:	:	:	:	:	:	:	:	:	:	B3~B60
	:	:	:	:	:	:	:	:	:	:	:	:	:	:	:	:	:	:	
	↓	0	0	0	0	0	0	0	0	0	0	0	0	1	0	1	1	1	
	Light	0	0	0	0	0	0	0	0	0	0	0	0	0	1	1	1	1	B62
	Blue	0	0	0	0	0	0	0	0	0	0	0	0	1	1	1	1	1	B63

Note 1) Definition of gray :

Rn: Red gray, Gn: Green gray, Bn: Blue gray (n=gray level)

Note 2) Input signal: 0 =Low level voltage, 1=High level voltage

5.5 Pixel Format in the display

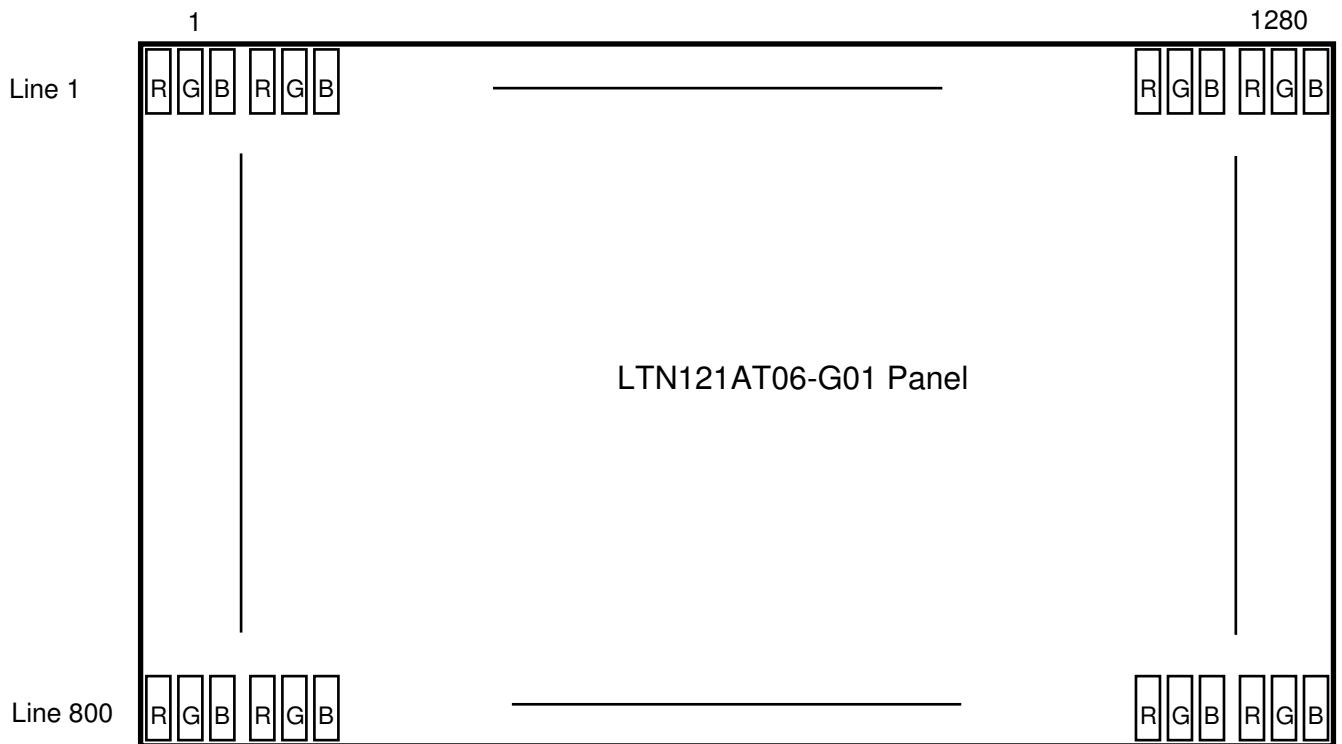

6. INTERFACE TIMING

6.1 Timing Parameters

Signal	Item	Symbol	Min.	Typ.	Max.	Unit	Note
Frame Frequency	Cycle	TV	804	816	860	Lines	
Vertical Active Display Term	Display Period	TVD	-	800	-	Lines	
One Line Scanning Time	Cycle	TH	1350	1415	1460	Clocks	
Horizontal Active Display Term	Display Period	THD	-	1280	-	Clocks	

6.2 Timing diagrams of interface signal

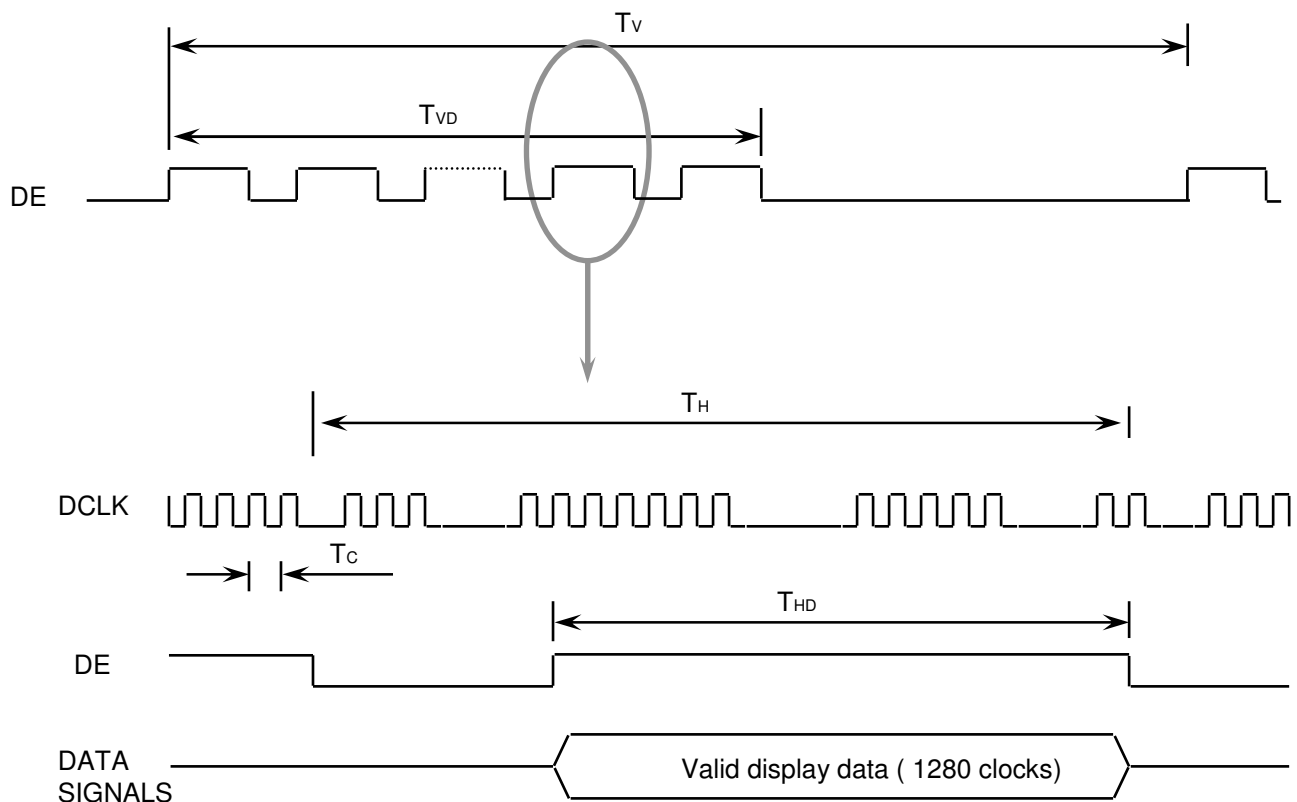

6.3 Power ON/OFF Sequence

preliminary

: To prevent a latch-up or DC operation of the LCD module, the power on/off sequence should be as the diagram below.

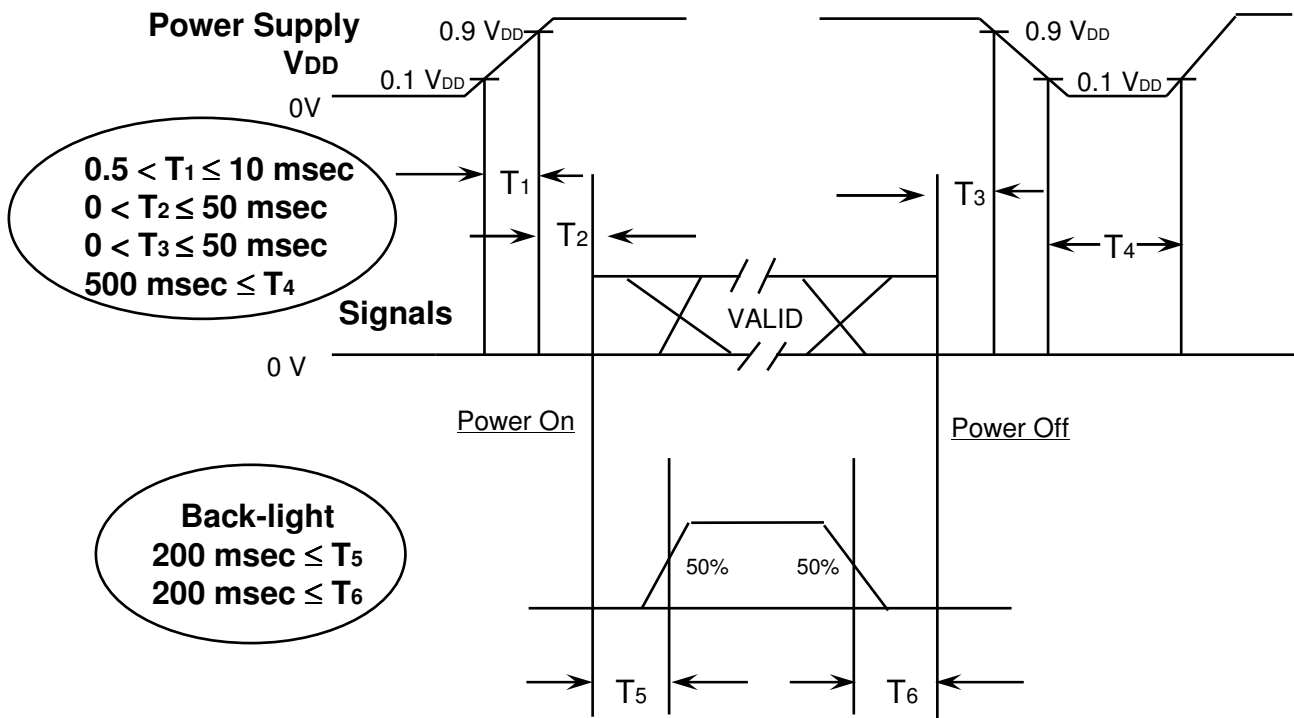

Power ON/OFF Sequence

- T1 : Vdd rising time from 10% to 90%
- T2 : The time from Vdd to valid data at power ON.
- T3 : The time from valid data off to Vdd off at power Off.
- T4 : Vdd off time for Windows restart
- T5 : The time from valid data to B/L enable at power ON.
- T6 : The time from valid data off to B/L disable at power Off.

NOTE.

- (1) The supply voltage of the external system for the module input should be the same as the definition of VDD.
- (2) Apply the lamp voltage within the LCD operation range. When the back-light turns on before the LCD operation or the LCD turns off before the back-light turns off, the display may momentarily become white.
- (3) In case of VDD = off level, please keep the level of input signals on the low or keep a high impedance.
- (4) T4 should be measured after the module has been fully discharged between power off and on period.
- (5) Interface signal shall not be kept at high impedance when the power is on.

7. Mechanical Outline Dimension

preliminary

Refer to the next page

This page will be replaced with the outline drawing after producing PDF file.

Z0-0-V-FR

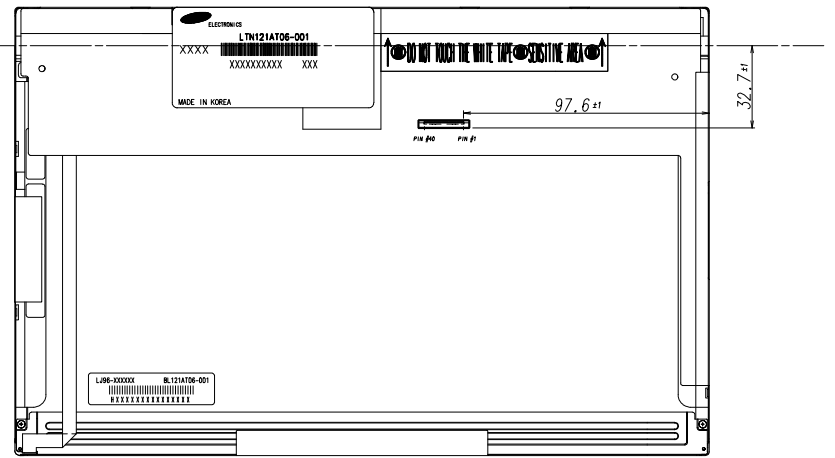
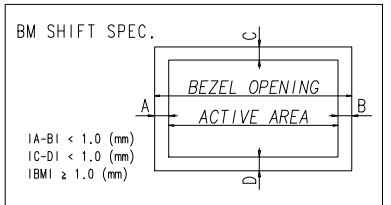
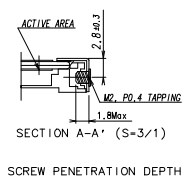
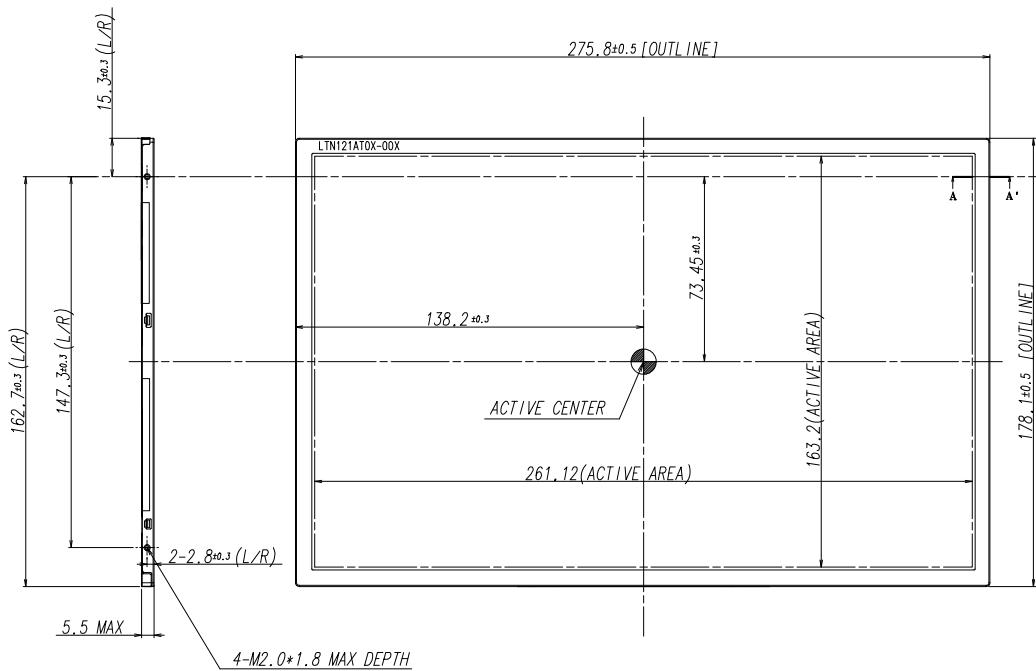

- * NOTE
- SIGNAL INTERFACE CONNECTOR TO BE SPECIFIED AS BELOW.
 - MAKER : JAE OR COMPATIBLE
 - INPUT CONNECTOR : JAE, F1-NXB40SL-HF10 (Locking type)
 - LED CONNECTOR FOR BACKLIGHT TO BE SPECIFIED AS BELOW.
 - MAKER : WOOJOO Electronics (TBD)
 - PART NO : 51441-1041 (TBD)
 - ALLOWED DEPTH OF USERHOLE SCREW INSERTION IS 1.8mm MAX.
 - MEASURING FORCE : 750 ± 250 gf-cm
 - MAXIMUM SCREW TORQUE : 2.5 kgf-cm

REV	DATE	DESCRIPTION OF REVISION				REASON	CHK'D BY
UNIT	mm	DRA'N BY	DES'D BY	CHK'D BY	APP'D BY	MODEL NAME	LTN121AT06-001
SCALE	1/1	S.H.LEE		I.S.LEE		PART/SHEET NAME	OUTLINE DIMENSION
TOLERANCE		06.04.25		06.04.25		SPEC. NO	
SAMSUNG ELECTRONICS						CODE NO.	VER. 000

8. PACKING

1. CARTON(Internal Package)

(1) Packing Form

Corrugated Cardboard box and Corrupad form as shock absorber

(2) Packing Method

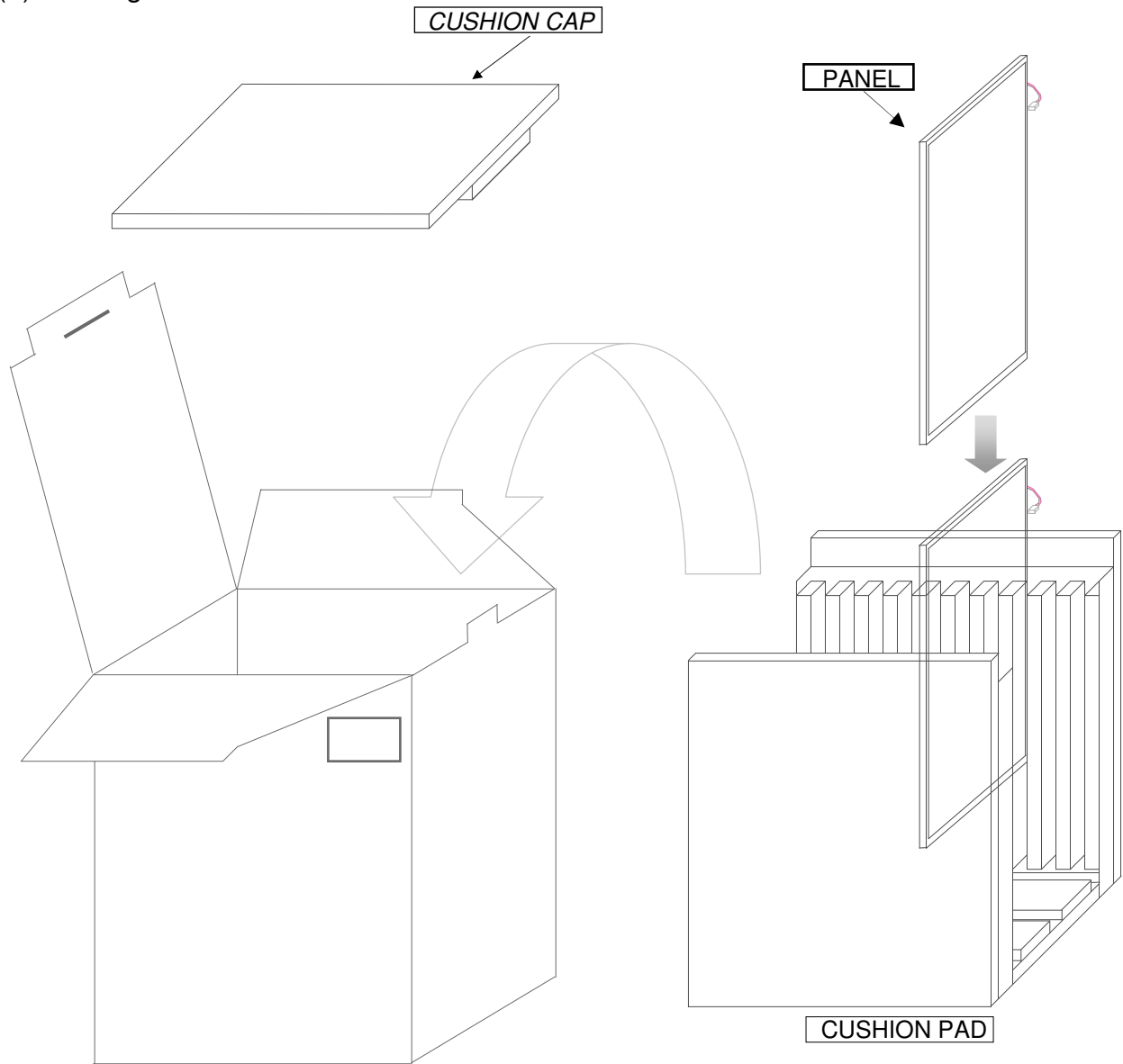

PACKING CASE

- Note 1) Total Weight : Approximately 4.0 kg
2) Acceptance number of piling : 10 sets
3) Carton size : 295(W) × 280(D) × 364(H)
4) MAX accumulation quantity : 5 cartons

(3)Packing Material

No	Part name	Quantity
1	Static electric protective sack	10
2	Packing case (Inner box) included shock absorber	1 set
3	Pictorial marking	2 pcs
4	Carton	1 set

9. MARKINGS & OTHERS

A nameplate bearing followed by is affixed to a shipped product at the specified location on each product.

(1)Parts number : LTN121AT06

(2)Revision code : 3 letters

(3)Lot number : X X X X XXX XX X **G01**

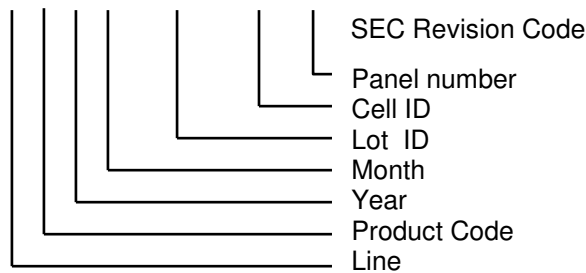

(4) Nameplate Indication

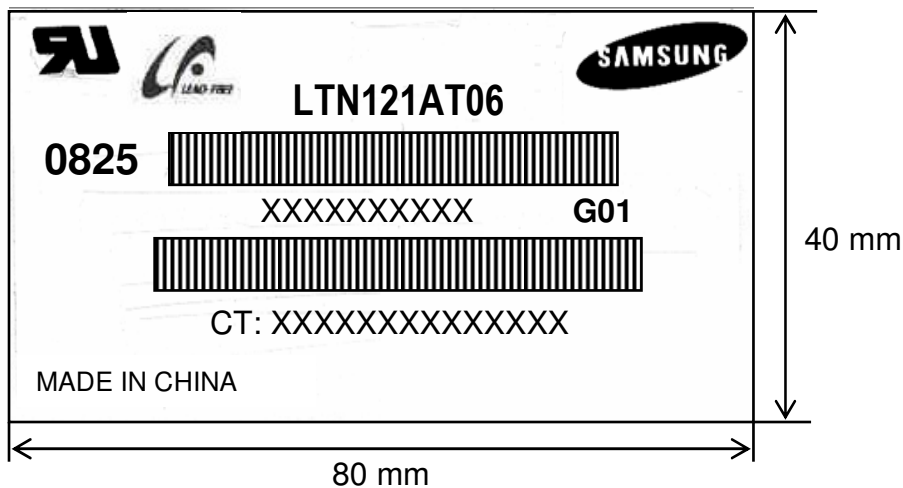

Parts name : LTN121AT06
 Lot number : XXXXXXXXXXXX
 Inspected work week : 0825 (2008 year 25th week)
 Product Revision Code : G01
 CT code : XXXXXXXXXXXXXXXX (Released after HP's approval)

(5) High voltage caution notice

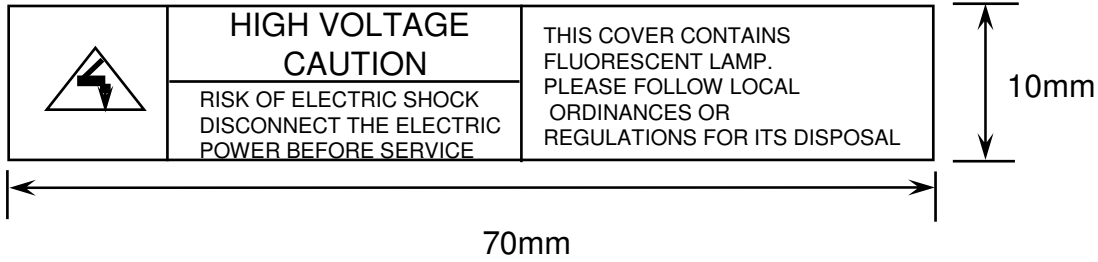

(6) Packing small box attach

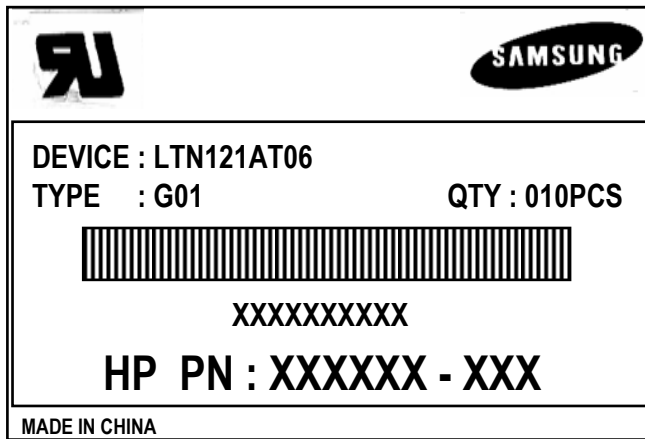

(7) Packing box Marking : Samsung TFT-LCD Brand Name



10. GENERAL PRECAUTIONS

preliminary

1. Handling

- (a) When the module is assembled, It should be attached to the system firmly using every mounting holes. Be careful not to twist and bend the modules.
- (b) Refrain from strong mechanical shock and / or any force to the module. In addition to damage, this may cause improper operation or damage to the module and CCFT back-light.
- (c) Note that polarizers are very fragile and could be easily damaged. Do not press or scratch the surface harder than a HB pencil lead.
- (d) Wipe off water droplets or oil immediately. If you leave the droplets for a long time, Staining and discoloration may occur.
- (e) If the surface of the polarizer is dirty, clean it using some absorbent cotton or soft cloth.
- (f) The desirable cleaners are water, IPA (Isopropyl Alcohol) or Hexane. Do not use Ketone type materials(ex. Acetone), Ethyl alcohol, Toluene, Ethyl acid or Methyl chloride. It might permanent damage to the polarizer due to chemical reaction.
- (g) If the liquid crystal material leaks from the panel, it should be kept away from the eyes or mouth. In case of contact with hands, legs or clothes, it must be washed away thoroughly with soap.
- (h) Protect the module from static, it may cause damage to the C-MOS Gate Array IC.
- (i) Use fingerstalls with soft gloves in order to keep display clean during the incoming inspection and assembly process.
- (j) Do not disassemble the module.
- (k) Do not pull or fold the lamp wire.
- (l) Do not adjust the variable resistor which is located on the back side.
- (m) Protection film for polarizer on the module shall be slowly peeled off just before use so that the electrostatic charge can be minimized.
- (n) Pins of I/F connector shall not be touched directly with bare hands.

2. STORAGE

- (a) Do not leave the module in high temperature, and high humidity for a long time.
It is highly recommended to store the module with temperature from 0 to 35 °C and relative humidity of less than 70%.
- (b) Do not store the TFT-LCD module in direct sunlight.
- (c) The module shall be stored in a dark place. It is prohibited to apply sunlight or fluorescent light during the store.

3. OPERATION

- (a) Do not connect, disconnect the module in the “ Power On” condition.
- (b) Power supply should always be turned on/off by following item 6.3
“ Power on/off sequence “.
- (c) Module has high frequency circuits. Sufficient suppression to the electromagnetic interference shall be done by system manufacturers. Grounding and shielding methods may be important to minimize the interference.
- (d) The cable between the back-light connector and its inverter power supply shall be a minimized length and be connected directly . The longer cable between the back-light and the inverter may cause lower luminance of lamp(CCFT) and may require higher startup voltage (Vs).
- (e) The standard limited warranty is only applicable when the module is used for general notebook applications. If used for purposes other than as specified, SEC is not to be held reliable for the defective operations. It is strongly recommended to contact SEC to find out fitness for a particular purpose.

4. OTHERS

- (a) Ultra-violet ray filter is necessary for outdoor operation.
- (b) Avoid condensation of water. It may result in improper operation or disconnection of electrode.
- (c) Do not exceed the absolute maximum rating value. (the supply voltage variation, input voltage variation, variation in part contents and environmental temperature, so on)
Otherwise the module may be damaged.
- (d) If the module displays the same pattern continuously for a long period of time, it can be the situation when the image “sticks” to the screen.
- (e) This module has its circuitry PCB's on the rear side and should be handled carefully in order not to be stressed.

11. EDID

preliminary

Address (HEX)	FUNCTION	Value	BIN	DEC	ASCII or Data	Notes
		HEX				
00	Header	00	00000000	0		EDID Header
01		FF	11111111	255		
02		FF	11111111	255		
03		FF	11111111	255		
04		FF	11111111	255		
05		FF	11111111	255		
06		FF	11111111	255		
07		00	00000000	0		
08	ID Manufacturer Name	4C	01001100	76	S	3 character ID
					E	
09		A3	10100011	163	C	"SEC"
0A	ID Product Code	41	01000001	65	[A]	
0B		4A	01001010	74	[J]	
0C	32-bit serial no.	00	00000000	0		
0D		00	00000000	0		
0E		00	00000000	0		
0F		00	00000000	0		
10	Week of manufacture	00	00000000	0		
11	Year of manufacture	12	00010010	18	2008	2008
12	EDID Structure Ver.	01	00000001	1	1	EDID Ver. 1.0
13	EDID revision #	03	00000011	3	3	EDID Rev. 3
14	Video input definition	80	10000000	128		
15	Max H image size	1A	00011010	26	26	26 cm(approx)
16	Max V image size	10	00010000	16	16	16 cm(approx)
17	Display Gamma	78	01111000	120	2.2	Gamma 2.2
18	Feature support	0A	00001010	10		
19	Red/green low bits	87	10000111	135		10000111
1A	Blue/white low bits	F5	11110101	245		11111110
1B	Red x/ high bits	94	10010100	148	0.580	Red x0.580= 1001010010
1C	Red y	57	01010111	87	0.340	Red y0.340= 0101011100
1D	Green x	4F	01001111	79	0.310	Green x0.310= 0100111101
1E	Green y	8C	10001100	140	0.550	Green y0.550= 1000110011
1F	Blue x	27	00100111	39	0.155	Blue x0.155= 0010011111
20	Blue y	27	00100111	39	0.155	Blue y0.155= 0010011111
21	White x	50	01010000	80	0.313	White x0.313= 0101000001
22	White y	54	01010100	84	0.329	White y0.329= 0101010001
23	Established timing 1	00	00000000	0		
24	Established timing 2	00	00000000	0		
25	Established timing 3	00	00000000	0		

26	Standard timing #1	01	00000001	1		not used	
27		01	00000001	1			
28	Standard timing #2	01	00000001	1		not used	
29		01	00000001	1			
2A	Standard timing #3	01	00000001	1		not used	
2B		01	00000001	1			
2C	Standard timing #4	01	00000001	1		not used	
2D		01	00000001	1			
2E	Standard timing #5	01	00000001	1		not used	
2F		01	00000001	1			
30	Standard timing #6	01	00000001	1		not used	
31		01	00000001	1			
32	Standard timing #7	01	00000001	1		not used	
33		01	00000001	1			
34	Standard timing #8	01	00000001	1		not used	
35		01	00000001	1			
36	Detailed timing/monitor descriptor #1	12	00010010	18	69.3	Main clock= 69.3 MHz	
37		1B	00011011	27			
38		00	00000000	0	1280	Hor active=640*2 pixels	
39		49	01001001	73	73	Hor blanking=135 pixels	
3A		50	01010000	80		4bit : 4bit	
3B		20	00100000	32	800	Vertical active=800 lines	
3C		36	00110110	54	54	Vertical blanking=16 lines	
3D		30	00110000	48		4bit : 4bit	
3E		10	00010000	16	16	Hor sync. Offset=16 pixels	
3F		30	00110000	48	48	H sync. Width=48 pixels	
40			13	00010011	19	1 3	V sync. Offset=1 lines V sync. Width=3 lines
41			00	00000000	0		2bit : 2bit :2bit :2bit
42			05	00000101	5	261	H image size= 261 mm(approx)
43			A3	10100011	163	163	V image size = 163 mm(approx)
44			10	00010000	16		
45			00	00000000	0		No Horizontal Border
46			00	00000000	0		No Vertical Border
47			19	00011001	25		
48		Detailed timing/monitor descriptor #2	00	00000000	0		Manufacturer Specified (Timing)
49			00	00000000	0		
4A	00		00000000	0			
4B	0F		00001111	15			
4C	00		00000000	0			
4D	00		00000000	0		Value=HSPWmin / 2	
4E	00		00000000	0		Value=HSPWmax / 2	
4F	00		00000000	0		Value=Thbpmin / 2	
50	00		00000000	0		Value=Thbpmax / 2	
51	00		00000000	0		Value=VSPWmin / 2	
52	00		00000000	0		Value=VSPWmax / 2	
53	00		00000000	0		Value=Tvpmin / 2	
54	00		00000000	0		Value=Tvpmax / 2	
55	23		00100011	35		Thpmin=value*2 + HA pixelclks	
56	87		10000111	135		Thpmax=value*2 + HA pixelclks	
57	02		00000010	2		Tvpmin=value*2 + VA lines	
58	64		01100100	100		Tvpmax=value*2 + VA lines	
59	00		00000000	0		Module revision	

5A	Detailed timing/monitor descriptor #3	00	00000000	0		ASCII Data String Tag
5B		00	00000000	0		
5C		00	00000000	0		
5D		FE	11111110	254		
5E		00	00000000	0		
5F		53	01010011	83	[S]	
60		41	01000001	65	[A]	
61		4D	01001101	77	[M]	
62		53	01010011	83	[S]	
63		55	01010101	85	[U]	
64		4E	01001110	78	[N]	
65		47	01000111	71	[G]	
66		0A	00001010	10	[^]	
67		20	00100000	32	[]	
68	20	00100000	32	[]		
69	20	00100000	32	[]		
6A	20	00100000	32	[]		
6B	20	00100000	32	[]		
6C	Detailed timing/monitor descriptor #4	00	00000000	0		Monitor Name Tag (ASCII)
6D		00	00000000	0		
6E		00	00000000	0		
6F		FE	11111110	254		
70		00	00000000	0		
71		31	00110001	49	[1]	
72		32	00110010	50	[2]	
73		31	00110001	49	[1]	
74		41	01000001	65	[A]	
75		54	01010100	84	[T]	
76		30	00110000	48	[0]	
77		36	00110110	54	[6]	
78		2D	00101101	45	[.]	
79		47	01000111	71	[G]	
7A	30	00110000	48	[0]		
7B	31	00110001	49	[1]		
7C	0A	00001010	10	[^]		
7D	20	00100000	32	[]		
7E	Extension Flag	00	00000000	0		
7F	Checksum	25	00100101	37		