

mass integrated

global part distribution • product lifecycle partner
excess inventory management • value-ad service provider



Data sheet provided by Mass Integrated

massintegrated.com • displayalliance.com

Please call +1.978.465.6190
Email: sales@massintegrated.com



ISO 9001: 2008

Mass Integrated complies with all DMCA takedown notices. Please send a formal DMCA Takedown Notice to Mass Integrated Systems, Inc. • 18 Henry Graf Jr. Road, Unit 1 • Newburyport, MA 01950.



SAMSUNG

ELECTRONICS

Preliminary



TO :

DATE : June. 19, 2009.

SAMSUNG TFT-LCD

MODEL NO. : LTN141AT12-

NOTE :

- Extension code [-X] :LTN141AT12-G
- Surface type [**Glare**]

Any Modification of Specification is not allowed without SEC's Permission.

SAMSUNG ELECTRONICS CO., LTD.



CONTENTS

Revision History	----- (3)
General Description	----- (4)
1. Absolute Maximum Ratings	----- (5)
1.1 Absolute Ratings of environment	
1.2 Electrical Absolute Ratings	
2. Optical Characteristics	----- (7)
3. Electrical Characteristics	----- (10)
3.1 TFT LCD Module	
3.2 Backlight Unit	
4. Block Diagram	----- (13)
4.1 TFT LCD Module	
5. Input Terminal Pin Assignment	----- (14)
5.1 Input Signal & Power	
5.2 LVDS Interface	
5.3 Timing Diagrams of LVDS For Transmitting	
5.4 Input Signals, Basic Display Colors and Gray Scale of Each Color.	
5.5 Pixel format	
5.6 LED FPC Connector & Pin Assignment	
6. Interface Timing	----- (20)
6.1 Timing Parameters	
6.2 Timing Diagrams of interface Signal	
6.3 Power ON/OFF Sequence	
7. Outline Dimension	----- (22)
8. Packing	----- (24)
9. Markings & Others	----- (25)
10. General Precaution	----- (27)

REVISION HISTORY

Preliminary

Date	Rev. No.	Page	Summary
June. 19. 2009	P00	All	LTN141AT12-XXX model spec was issued first.

GENERAL DESCRIPTION

DESCRIPTION

LTN141AT12 is a color active matrix TFT (Thin Film Transistor) liquid crystal display (LCD) that uses amorphous silicon TFT as a switching devices. This model is composed of a TFT LCD panel, a driver circuit and a backlight unit. The resolution of a 14.1" contains 1,280 x 800 pixels and can display up to 262,144 colors. 6 O'clock direction is the Optimum viewing angle.

FEATURES

- High contrast ratio, high aperture structure
- 1280 x 800 pixels resolution
- Low power consumption
- Fast Response
- DE (Data enable) only mode
- 3.3V LVDS Interface
- Onboard EEDID chip

APPLICATIONS

- Notebook PC
- If the usage of this product is not for PC application, but for others, please contact SEC.

GENERAL INFORMATION

Item	Specification	Unit	Note
Display area	303.36(H) x 189.6(V) (14.1" diagonal)	mm	
Driver element	a-Si TFT active matrix		
Display colors	262,144		
Number of pixel	1280 x RGB(3) x 800	pixel	16 : 10
Pixel arrangement	RGB vertical stripe		
Pixel pitch	0.2370(H) x 0.2370(V) (TYP.)	mm	
Display Mode	Normally white		
Surface treatment	Haze 0, Hard-Coating 3H		Glare

Mechanical Information

Item		Min.	Typ.	Max.	Unit	Note
Module size	Horizontal (H)	319.0	319.5	320.0	mm	w/o converter ass'y
	Vertical (V)	205.0	205.5	206.0	mm	
	Depth (D)	-	-	5.5	mm	
Weight		-	390	440	g	LCD module only (w/o converter)

1. ABSOLUTE MAXIMUM RATINGS

1.1 ENVIRONMENTAL ABSOLUTE RATINGS

Item	Symbol	Min.	Max.	Unit	Note
Storage temperate	TSTG	-20	60	°C	(1)
Operating temperate (Temperature of glass surface)	TOPR	0	50	°C	(1)
Shock (non-operating)	Snop	-	240	G	(2),(4)
Vibration (non-operating)	Vnop	-	2.41	G	(3),(4)

Note (1) Temperature and relative humidity range are shown in the figure below.

95 % RH Max. (40 °C ≥ Ta)

Maximum wet - bulb temperature at 39 °C or less. (Ta > 40 °C) No condensation

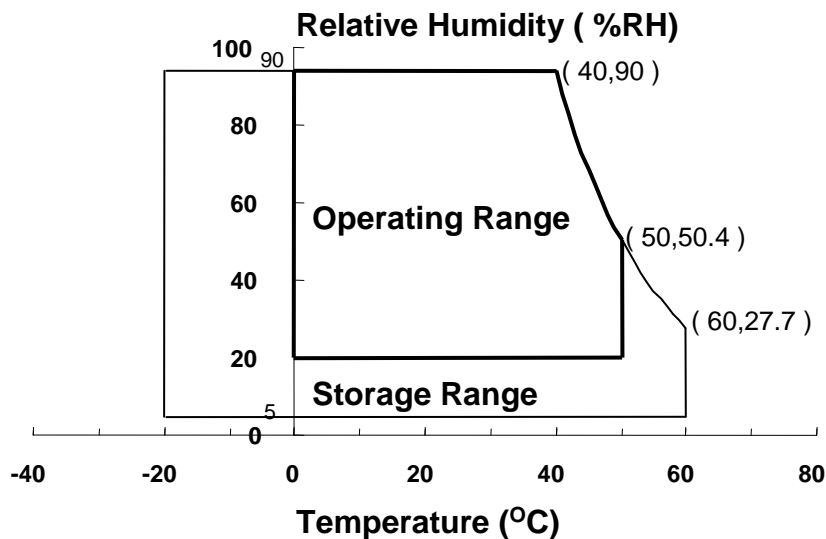

(2) 2ms, half sine wave, one time for ±X, ±Y, ±Z.

(3) 5 - 500 Hz, random vibration, 30min for X, Y, Z.

(4) At testing Vibration and Shock, the fixture in holding the Module to be tested have to be hard and rigid enough so that the Module would not be twisted or bent by the fixture.

1.2 ELECTRICAL ABSOLUTE RATINGS

(1) TFT LCD MODULE

 $V_{DD} = 3.3V$, $V_{SS} = GND = 0V$

Item	Symbol	Min.	Max.	Unit	Note
Power Supply Voltage	V_{DD}	$V_{SS} - 0.3$	3.6	V	(1)
Logic input Voltage	V_{DD}	$V_{SS} - 0.3$	3.6	V	(1)

Note (1) Within T_a (25 ± 2 °C)

2. OPTICAL CHARACTERISTICS

The following items are measured under stable conditions. The optical characteristics should be measured in a dark room or equivalent state with the methods shown in Note (5).
Measuring equipment : TOPCON BM-5A and PR-650

* Ta = 25 ± 2 °C, VDD=3.3V, fv= 60Hz, fdCLK = 75.01MHz

Item		Symbol	Condition	Min.	Typ.	Max	Unit	Note
Contrast Ratio (5 Points)		CR		400	500	-	-	Antiglare (1), (2), (5)
Response Time at Ta (Rising + Falling)		T _{RT,BW}		-	16	25	msec	(1), (3)
Average Luminance of White (5 Points)		Y _{L,AVE}		200	220	-	cd/m ²	I _L =6.0mA (1), (4)
Color Chromaticity (CIE)	Red	R _X	Normal Viewing Angle φ = 0 θ = 0	(0.560)	(0.590)	(0.620)	-	(1), (5) PR-650
		R _Y		(0.310)	(0.340)	(0.370)		
	Green	G _X		(0.290)	(0.320)	(0.350)		
		G _Y		(0.510)	(0.540)	(0.570)		
	Blue	B _X		(0.125)	(0.155)	(0.185)		
		B _Y		(0.110)	(0.140)	(0.170)		
	White	W _X		0.285	0.315	0.345		
		W _Y		0.300	0.330	0.360		
Viewing Angle	Hor.	θ _L	CR ≥ 10	40	45	-	Degrees	(1), (5) BM-5A
		θ _R		40	45	-		
	Ver.	φ _H		15	20	-		
		φ _L		30	45	-		
13 Points White Variation		δ _L		-	(1.4)	(1.7)	-	(6)

Note 1) Definition of Viewing Angle : Viewing angle range($10 \leq C/R$, $100 \leq C/R$)

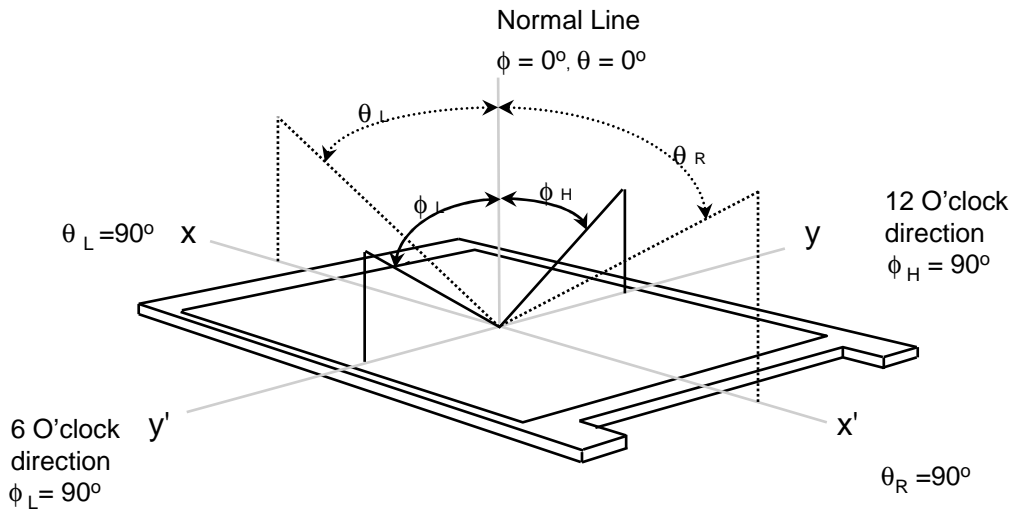

Note 2) Definition of Contrast Ratio (CR) : Ratio of gray max (Gmax) ,gray min (Gmin) at 5 points(4, 5, 7, 9, 10)

$$CR = \frac{CR(4) + CR(5) + CR(7) + CR(9) + CR(10)}{5}$$

Points : (4) , (5) , (7) , (9) , (10) at the figure of Note (6).

Note 3) Definition of Response time :

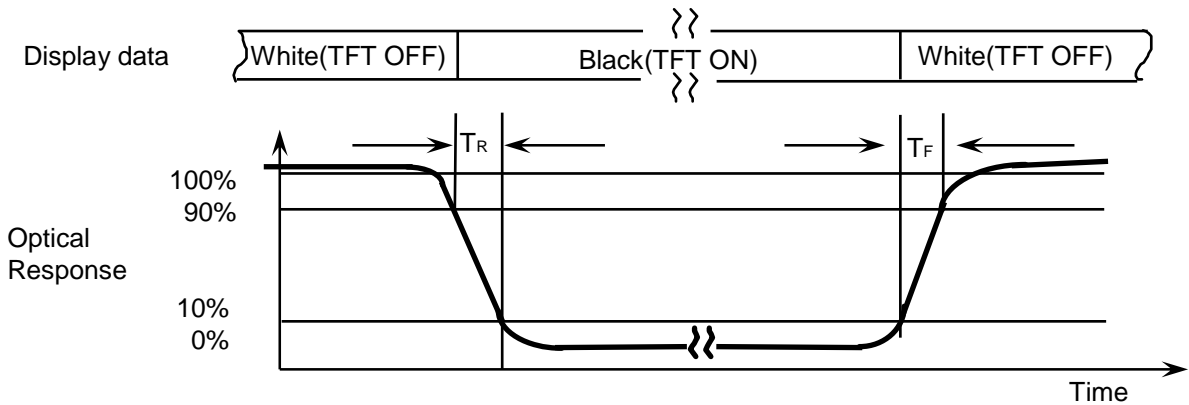

Note 4) Definition of Average Luminance of White : measure the luminance of white at 5 points.

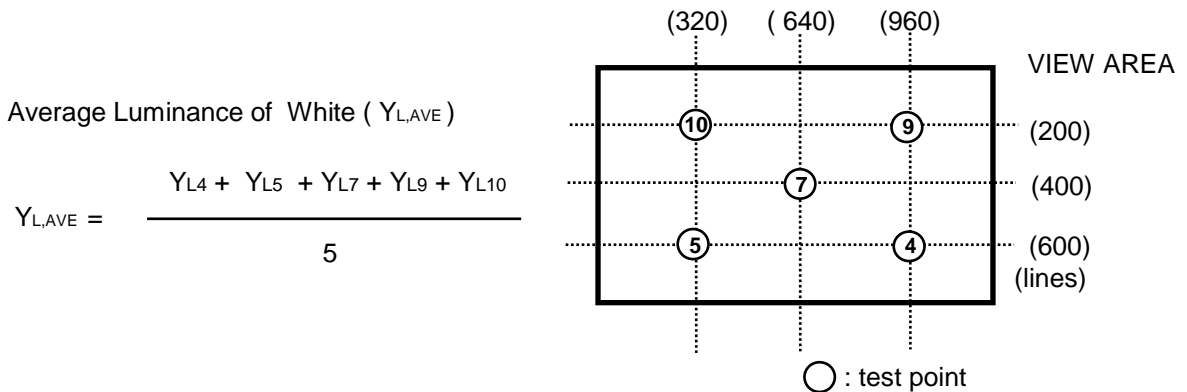

Average Luminance of White ($Y_{L,AVE}$)

$$Y_{L,AVE} = \frac{Y_{L4} + Y_{L5} + Y_{L7} + Y_{L9} + Y_{L10}}{5}$$

Note 5) After stabilizing and leaving the panel alone at a given temperature for 30 min , the measurement should be executed. Measurement should be executed in a stable, windless, and dark room. 30 min after lighting the backlight. This should be measured in the center of screen.
 Environment condition : $T_a = 25 \pm 2 \text{ }^\circ\text{C}$

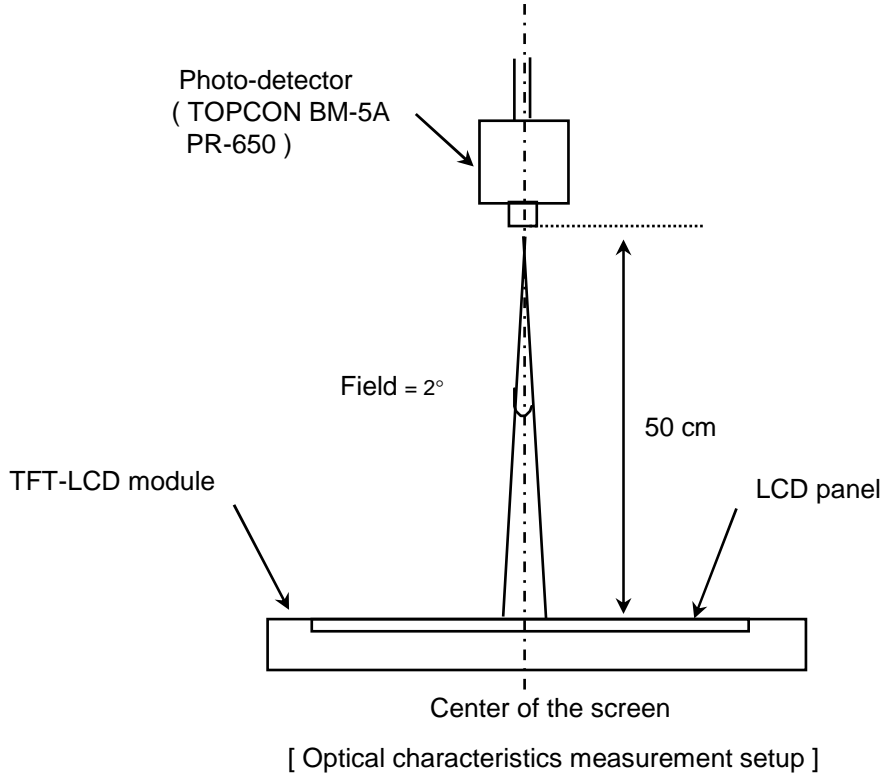

Note 6) Definition of 13 points white variation (δL), CR variation(C_{VER}) [① ~ ⑬]

$$\delta L = \frac{\text{Maximum luminance of 13 points}}{\text{Minimum luminance of 13 points}}$$

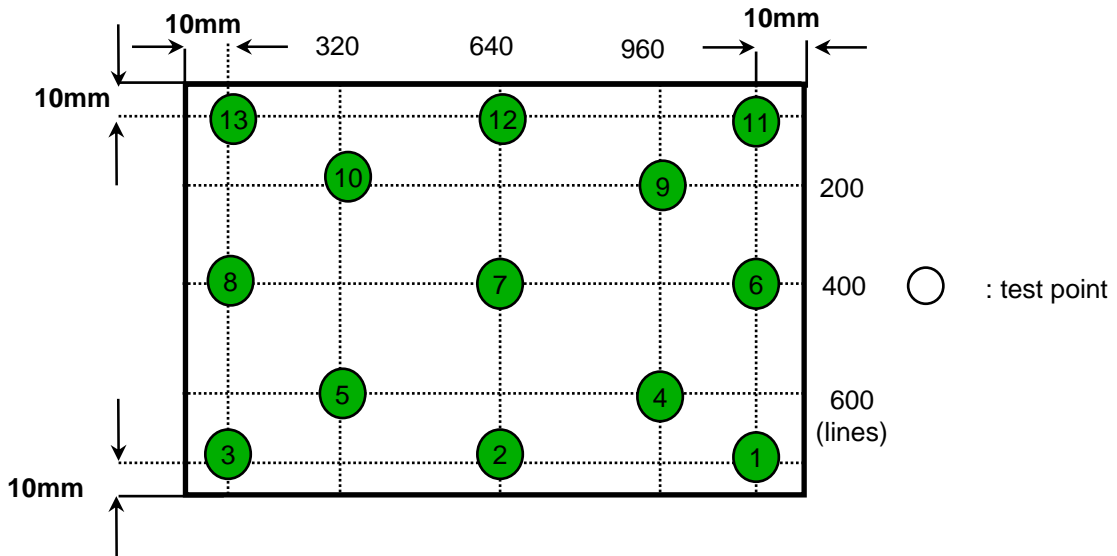

3. ELECTRICAL CHARACTERISTICS

3.1 TFT LCD MODULE

Ta= 25 ± 2°C

Item	Symbol	Min.	Typ.	Max.	Unit	Note	
Voltage of Power Supply	V _{DD}	3.0	3.3	3.6	V		
Differential Input Voltage for LVDS Receiver Threshold	High	V _{IH}	-	-	+100	mV	V _{CM} = +1.2V
	Low	V _{IL}	-100	-	-	mV	
Vsync Frequency	f _v	-	60	-	Hz		
Hsync Frequency	f _h	-	48.96	-	KHz	f _v *816	
Main Frequency	f _{DCLK}	65	75.01	85	MHz	f _h *1532	
Rush Current	I _{RUSH}	-	-	1.5	A	(4)	
Current of Power Supply	White	I _{DD}	-	290	-	mA	(2),(3)*a
	Mosaic		-	300	-	mA	(2),(3)*b
	V. stripe		-	350	485	mA	(2),(3)*c

Note (1) Display data pins and timing signal pins should be connected.(GND = 0V)

(2) f_v = 60Hz, f_{DCLK} = 75.01MHz, V_{DD} = 3.3V , DC Current.

(3) Power dissipation pattern

*a) White Pattern

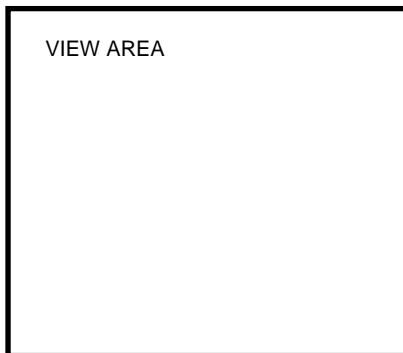

*b) Mosaic Pattern

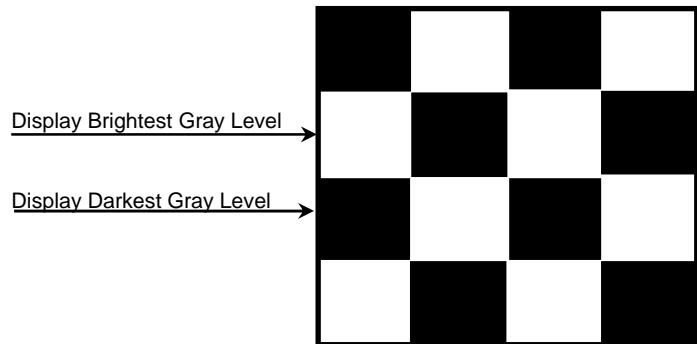

*c) 1dot Vertical stripe pattern

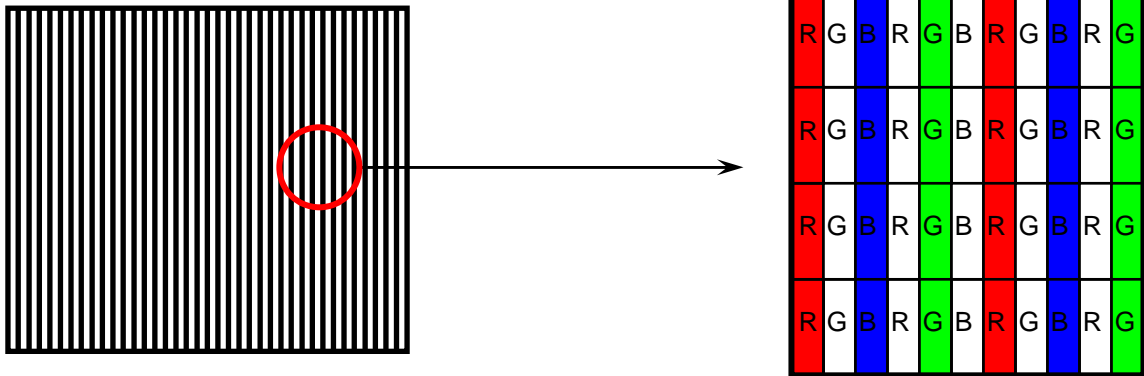

4) Rush current measurement condition

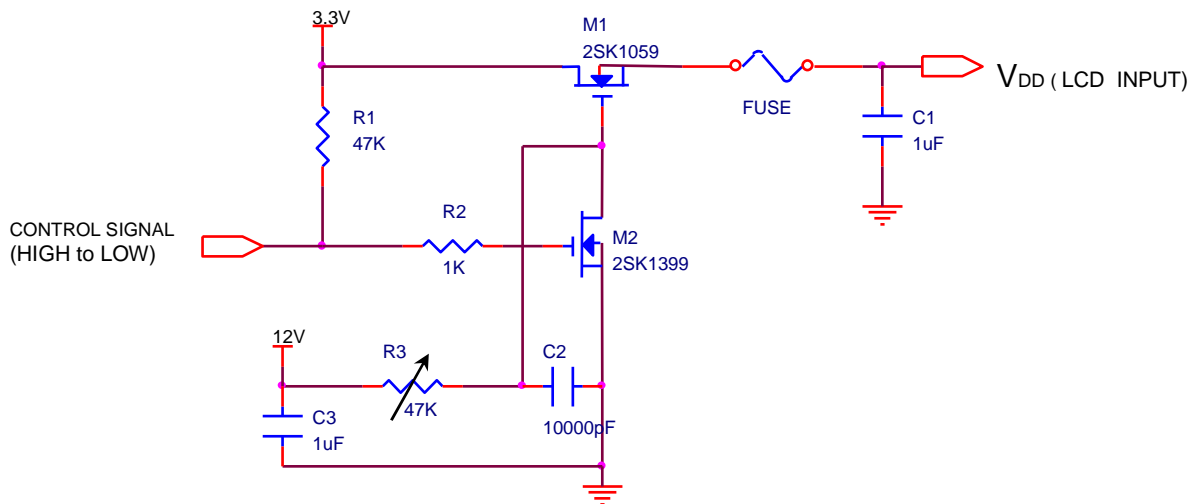

V_{DD} rising time is 470us

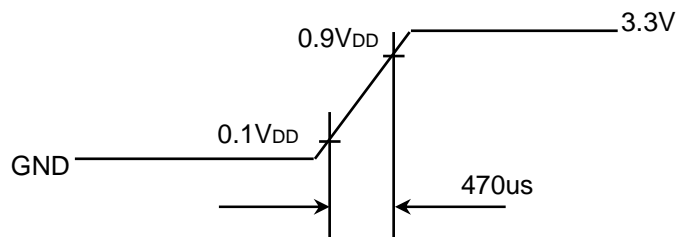

3.2 BACK-LIGHT UNIT

Ta= 25 ± 2 °C

Item	Symbol	Min.	Typ.	Max.	Unit	Note
LED Forward Current	IF	-	(20)	-	mA	
LED Forward Voltage	VF	-	(3.2)	-	V	
LED Array Voltage	VP	-	(22.4)	-	V	VF X 7 LEDs
Power Consumption	P	-	(2.68)	-	W	IF x VF x 42 LEDs
Operating Life Time	Hr	10,000	-	-	Hour	(1)

Note (1) Life time (Hr) of LEDs can be defined as the time in which it continues to operate under the condition Ta= 25 ± 2 °C and IF = 20.0 mArms until one of the following event occurs.

1. When the brightness becomes 50% or lower than the original.

4. BLOCK DIAGRAM

4.1 TFT LCD Module

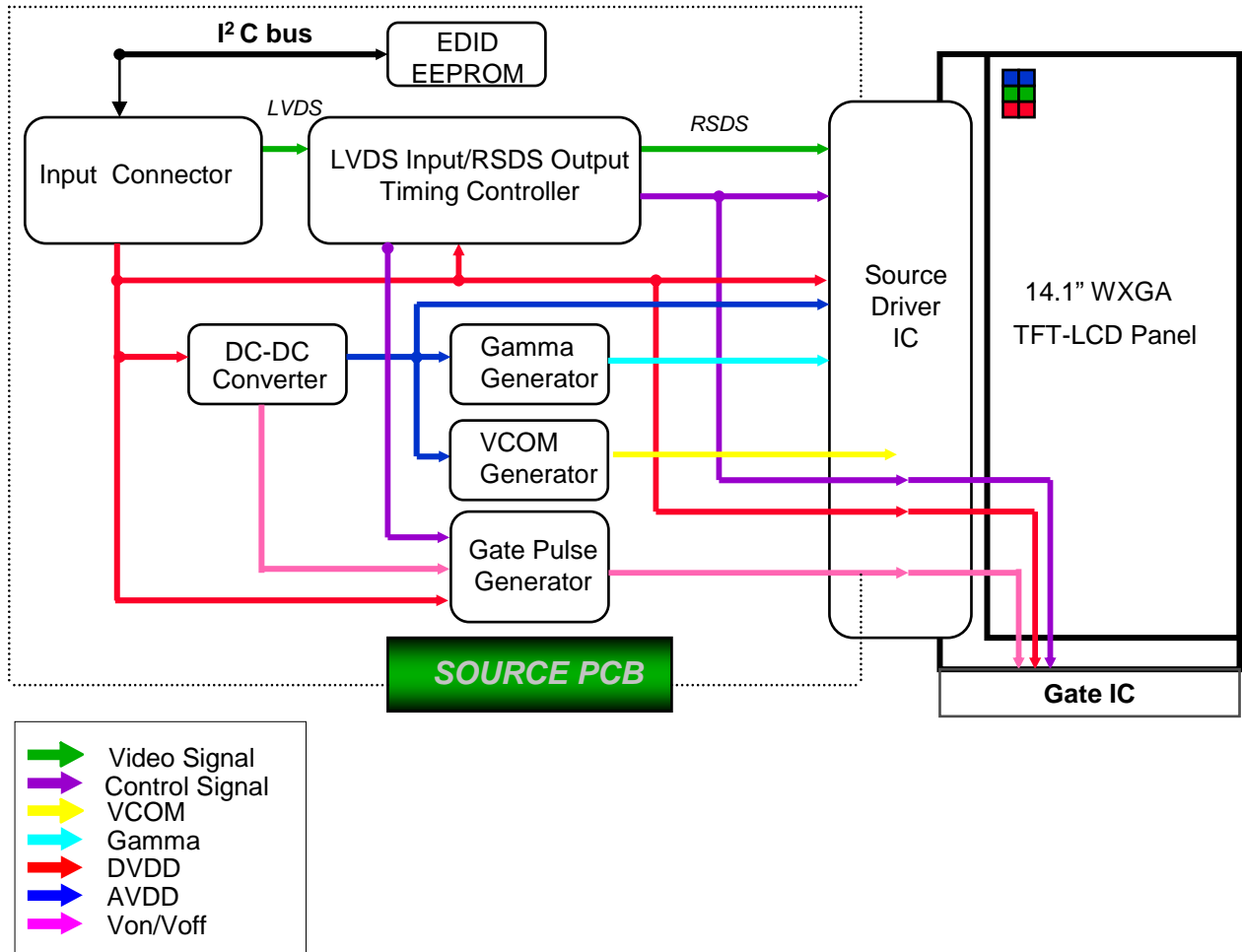

5. INPUT TERMINAL PIN ASSIGNMENT

5.1. Input Signal & Power (LVDS, Connector : JAE FI-XB30SRLZ-HF11 or compatible)
Mating Connector : JAE FI-X30M or compatible)

No.	Symbol	Function	Polarity	Remarks
1	VSS	Ground		
2	VDD	POWER SUPPLY +3.3V		
3	VDD	POWER SUPPLY +3.3V		
4	VEEDID	DDC 3.3V Power		
5	BIST	Panel BIST enable		
6	CLKEDID	DDC Clock		
7	DATAEDID	DDC data		
8	RxIN0-	LVDS Differential Data INPUT (R0-R5,G0)	Negative	
9	RxIN0+	LVDS Differential Data INPUT (R0-R5,G0)	Positive	
10	GND	Ground		
11	RxIN1-	LVDS Differential Data INPUT (G1-G5,B0-B1)	Negative	
12	RxIN1+	LVDS Differential Data INPUT (G1-G5,B0-B1)	Positive	
13	GND	Ground		
14	RxIN2-	LVDS Differential Data INPUT (B2-B5,Sync,DE)	Negative	
15	RxIN2+	LVDS Differential Data INPUT (B2-B5,Sync,DE)	Positive	
16	Vss	Ground		
17	ClkIN-	LVDS Differential Clock INPUT	Negative	
18	ClkIN+	LVDS Differential Clock INPUT	Positive	
19	Vss	Ground		
20	NC	No connect		
21	NC	No connect		
22	NC	No connect		
23	NC	No connect		
24	NC	No connect		
25	NC	No connect		
26	NC	No connect		
27	NC	No connect		
28	NC	No connect		
29	NC	No connect		
30	NC	No connect		

5.2 LVDS Interface : Transmitter DS90CF363 or Compatible

LVDS

Pin No.	Name	RGB Signal	Pin No.	Name	RGB Signal
44	TxIN0	RO0	12	TxIN11	GO5
45	TxIN1	RO1	13	TxIN12	BO0
47	TxIN2	RO2	15	TxIN13	BO1
48	TxIN3	RO3	16	TxIN14	BO2
1	TxIN4	RO4	18	TxIN15	BO3
3	TxIN5	RO5	19	TxIN16	BO4
4	TxIN6	GO0	20	TxIN17	BO5
6	TxIN7	GO1	22	TxIN18	Hsync
7	TxIN8	GO2	23	TxIN19	Vsync
9	TxIN9	GO3	25	TxIN20	DE
10	TxIN10	GO4	26	TxCLK IN	Clock

LVDS Interface

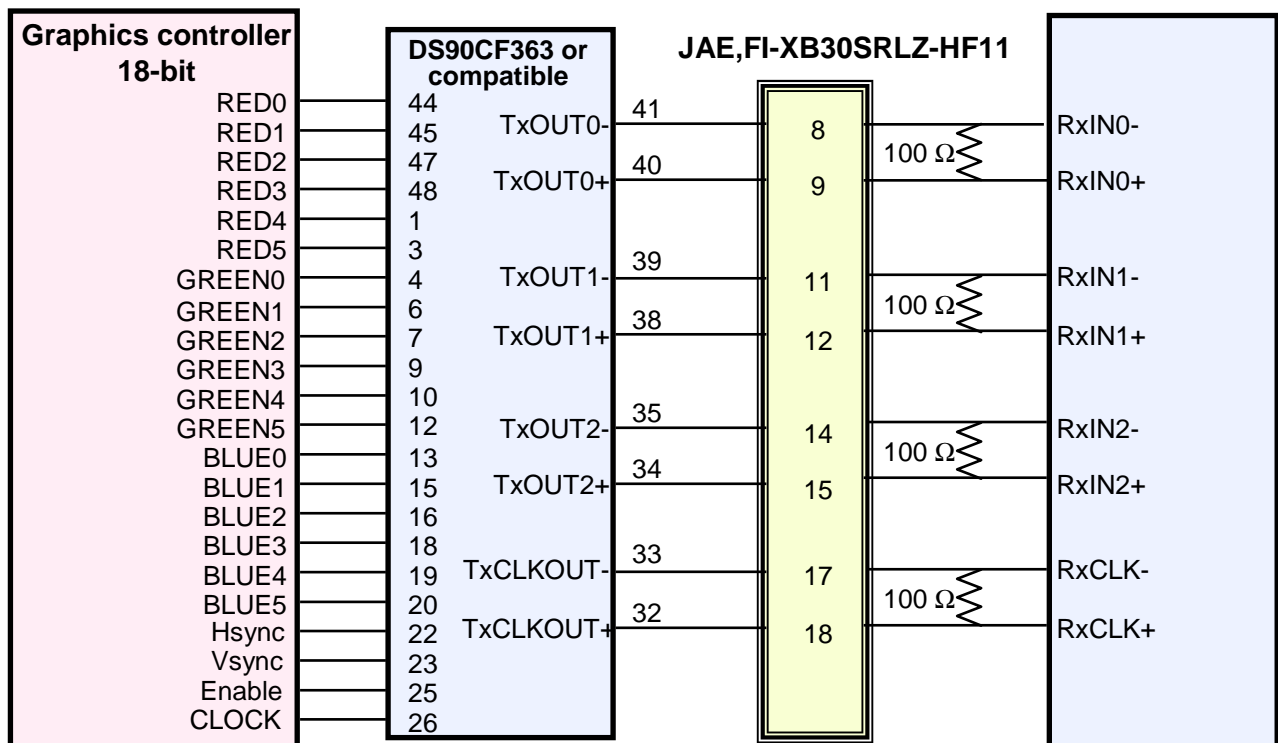

Note : The LCD Module uses a 100ohm resistor between positive and negative lines of each receiver input.

5.3 Timing Diagrams of LVDS For Transmission

LVDS Receiver : Integrated T-CON

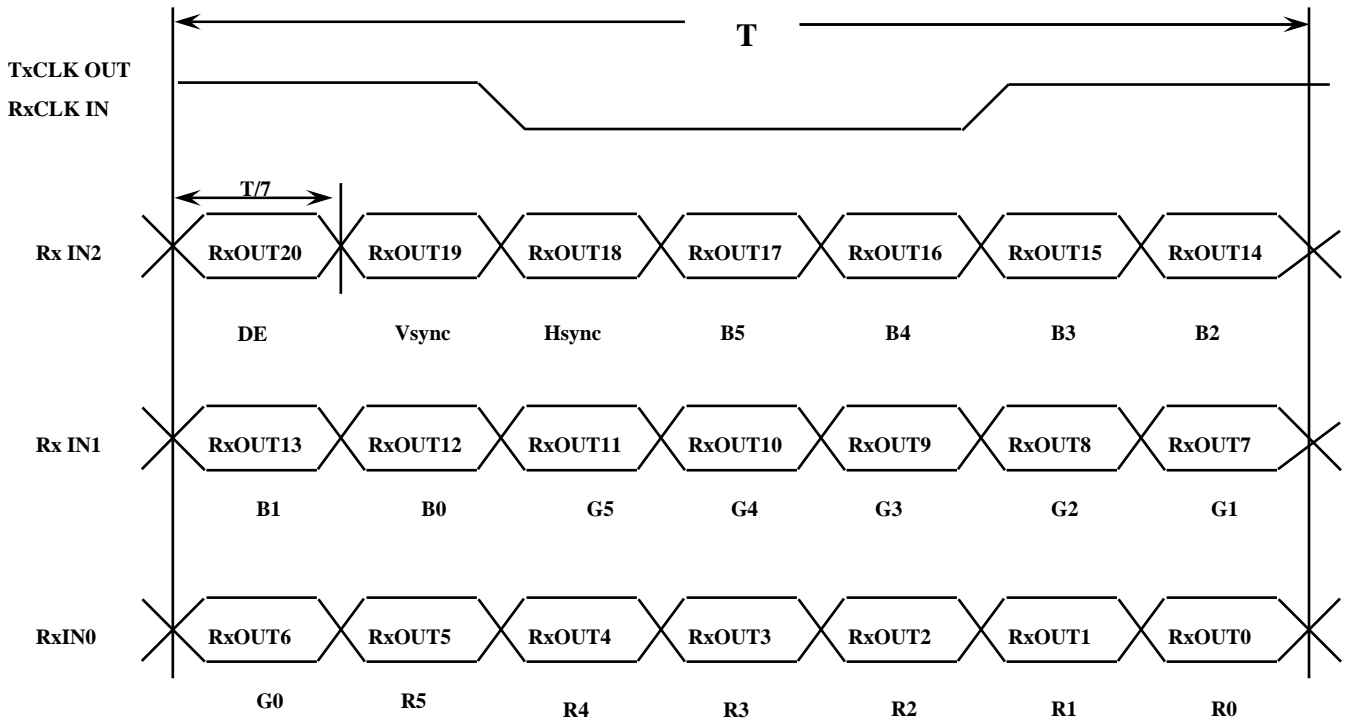

5.5 Input Signals, Basic Display Colors and Gray Scale of Each Color

Color	Display	Data Signal																Gray Scale Level	
		Red					Green					Blue							
		R0	R1	R2	R3	R4	R5	G0	G1	G2	G3	G4	G5	B0	B1	B2	B3		45
Basic Colors	Black	0	0	0	0	0	0	0	0	0	0	0	0	0	0	0	0	0	-
	Blue	0	0	0	0	0	0	0	0	0	0	0	0	1	1	1	1	1	-
	Green	0	0	0	0	0	0	1	1	1	1	1	1	0	0	0	0	0	-
	Cyan	0	0	0	0	0	0	1	1	1	1	1	1	1	1	1	1	1	-
	Red	1	1	1	1	1	1	0	0	0	0	0	0	0	0	0	0	0	-
	Magenta	1	1	1	1	1	1	0	0	0	0	0	0	1	1	1	1	1	-
	Yellow	1	1	1	1	1	1	1	1	1	1	1	1	0	0	0	0	0	-
	White	1	1	1	1	1	1	1	1	1	1	1	1	1	1	1	1	1	-
Gray Scale Of Red	Black	0	0	0	0	0	0	0	0	0	0	0	0	0	0	0	0	0	R0
	Dark	1	0	0	0	0	0	0	0	0	0	0	0	0	0	0	0	0	R1
	↑	0	1	0	0	0	0	0	0	0	0	0	0	0	0	0	0	0	R2
	:	:	:	:	:	:	:	:	:	:	:	:	:	:	:	:	:	:	R3-R60
	:	:	:	:	:	:	:	:	:	:	:	:	:	:	:	:	:	:	
	↓	1	0	1	1	1	1	0	0	0	0	0	0	0	0	0	0	0	R61
	Light	0	1	1	1	1	1	0	0	0	0	0	0	0	0	0	0	0	R62
	Red	1	1	1	1	1	1	0	0	0	0	0	0	0	0	0	0	0	R63
Gray Scale Of Green	Black	0	0	0	0	0	0	0	0	0	0	0	0	0	0	0	0	0	G0
	Dark	0	0	0	0	0	0	1	0	0	0	0	0	0	0	0	0	0	G1
	↑	0	0	0	0	0	0	0	1	0	0	0	0	0	0	0	0	0	G2
	:	:	:	:	:	:	:	:	:	:	:	:	:	:	:	:	:	:	G3-G60
	:	:	:	:	:	:	:	:	:	:	:	:	:	:	:	:	:	:	
	↓	0	0	0	0	0	0	1	0	1	1	1	1	0	0	0	0	0	G61
	Light	0	0	0	0	0	0	0	1	1	1	1	1	0	0	0	0	0	G62
	Green	0	0	0	0	0	0	1	1	1	1	1	1	0	0	0	0	0	G63
Gray Scale Of Blue	Black	0	0	0	0	0	0	0	0	0	0	0	0	0	0	0	0	0	B0
	Dark	0	0	0	0	0	0	0	0	0	0	0	0	1	0	0	0	0	B1
	↑	0	0	0	0	0	0	0	0	0	0	0	0	0	1	0	0	0	B2
	:	:	:	:	:	:	:	:	:	:	:	:	:	:	:	:	:	:	B3-B60
	:	:	:	:	:	:	:	:	:	:	:	:	:	:	:	:	:	:	
	↓	0	0	0	0	0	0	0	0	0	0	0	0	1	0	1	1	1	B61
	Light	0	0	0	0	0	0	0	0	0	0	0	0	0	1	1	1	1	B62
	Blue	0	0	0	0	0	0	0	0	0	0	0	0	1	1	1	1	1	B63

Note 1) Definition of gray :

Rn: Red gray, Gn: Green gray, Bn: Blue gray (n=gray level)

Note 2) Input signal: 0 =Low level voltage, 1=High level voltage

5.6 Pixel Format in the display

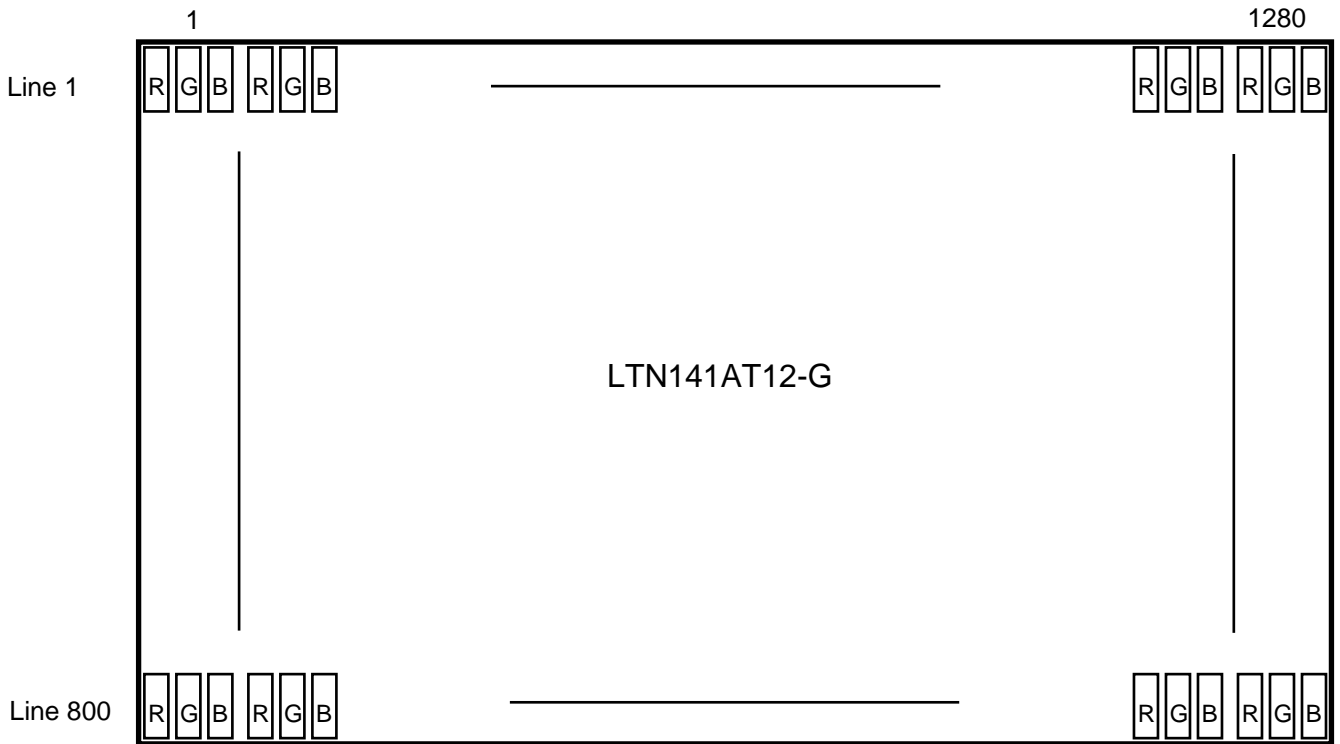

5.6 LED FPC Connector & Pin Assignment

LED FPC Connector : Uju PF050-010B-C11
or Compatible

Pin No.	Symbol	Comments
1	LED FB1	LCD channel 1 cathode
2	LED FB2	LCD channel 2 cathode
3	LED FB3	LCD channel 3 cathode
4	LED FB4	LCD channel 4 cathode
5	LED FB5	LCD channel 5 cathode
6	N/C	LCD channel 6 cathode (Maybe NC if channel<6)
7	N/C	LCD channel 7 cathode(Maybe NC if channel<7)
8	N/C	LCD channel 8 cathode(Maybe NC if channel<8)
9	N/C	-
10	VDD_LED	LED power supply
11	VDD_LED	LED power supply
12	VDD_LED	LED power supply

6. INTERFACE TIMING

6.1 Timing Parameters

Signal	Item	Symbol	Min.	Typ.	Max.	Unit	Note
Frame Frequency	Cycle	T_V	806	816	833	Lines	
Vertical Active Display Term	Display Period	T_{VD}	-	800	-	Lines	
One Line Scanning Time	Cycle	T_H	1320	1408	1650	Clocks	
Horizontal Active Display Term	Display Period	T_{HD}	-	1280	-	Clocks	

6.2 Timing diagrams of interface signal

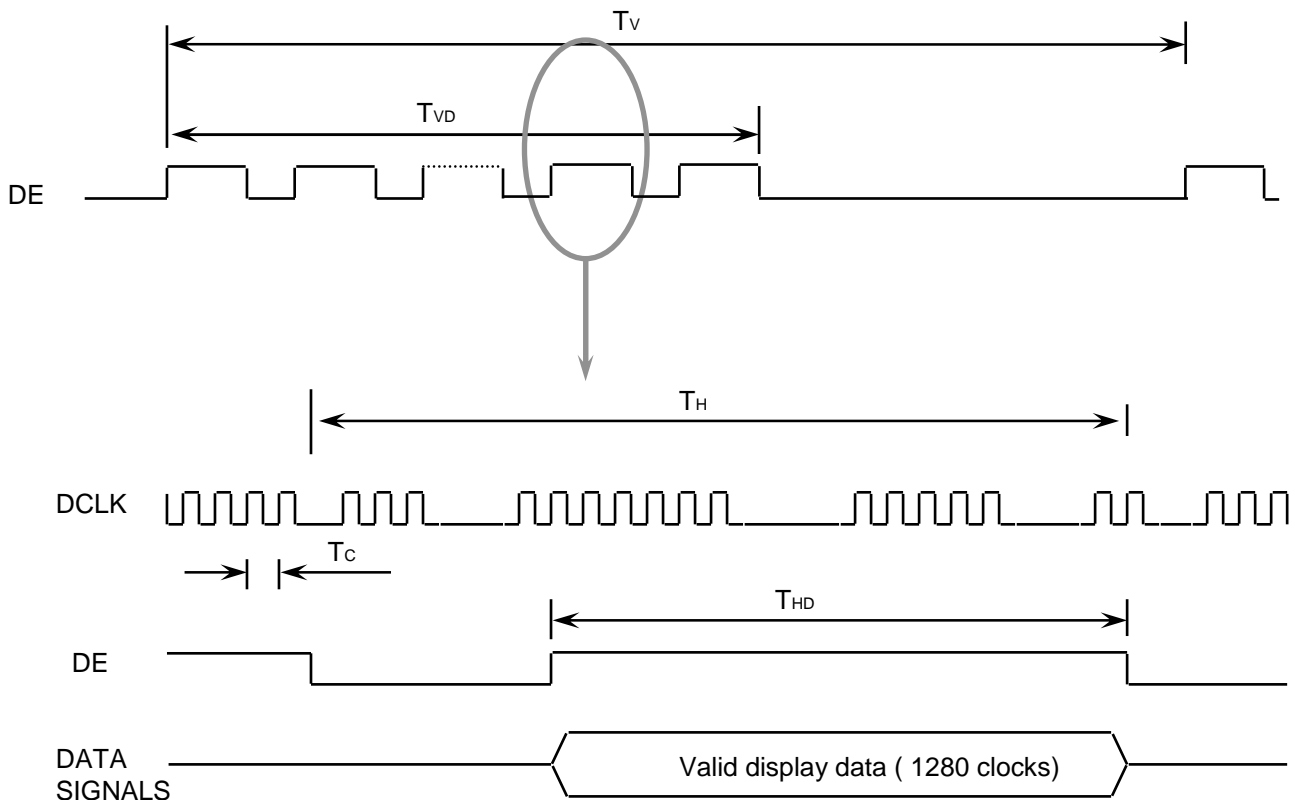

6.3 Power ON/OFF Sequence

Preliminary

: To prevent a latch-up or DC operation of the LCD module, the power on/off sequence should be as the diagram below.

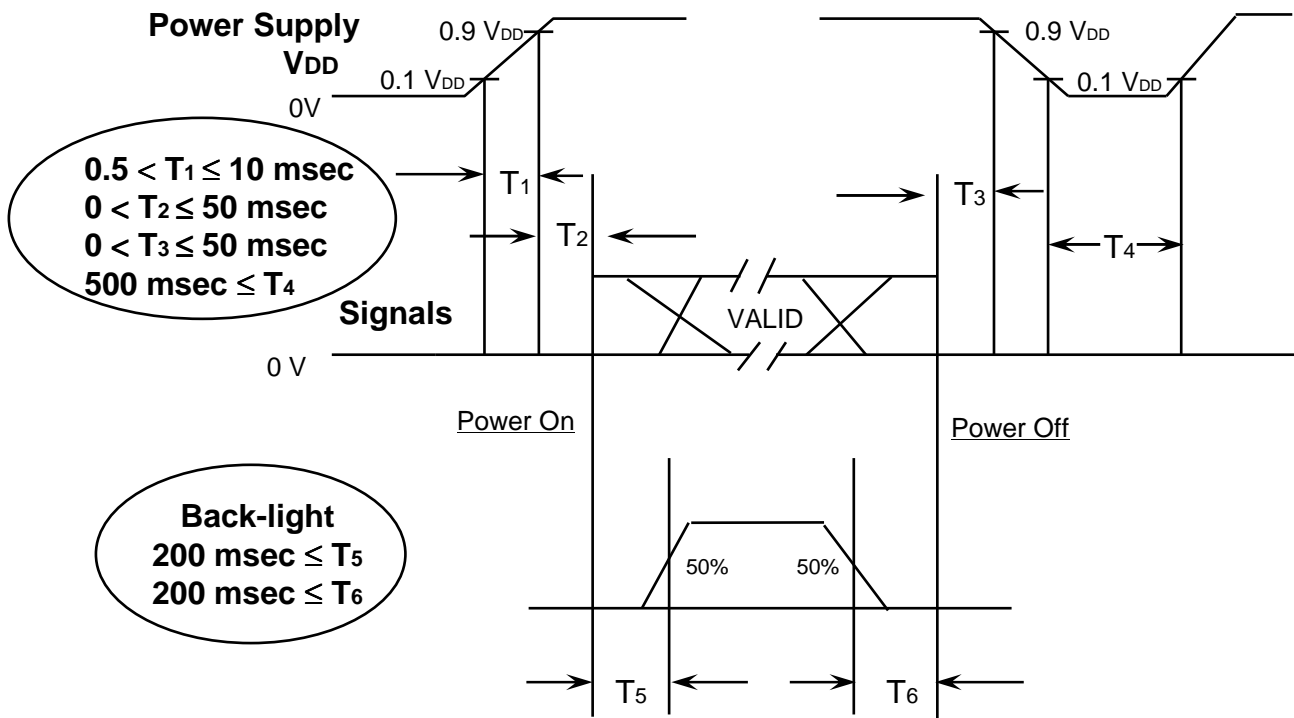

Power ON/OFF Sequence

- T1 : Vdd rising time from 10% to 90%
- T2 : The time from Vdd to valid data at power ON.
- T3 : The time from valid data off to Vdd off at power Off.
- T4 : Vdd off time for Windows restart
- T5 : The time from valid data to B/L enable at power ON.
- T6 : The time from valid data off to B/L disable at power Off.

NOTE.

- (1) The supply voltage of the external system for the module input should be the same as the definition of V_{DD}.
- (2) Apply the lamp voltage within the LCD operation range. When the back-light turns on before the LCD operation or the LCD turns off before the back-light turns off, the display may momentarily become white.
- (3) In case of V_{DD} = off level, please keep the level of input signals on the low or keep a high impedance.
- (4) T₄ should be measured after the module has been fully discharged between power off and on period.
- (5) Interface signal shall not be kept at high impedance when the power is on.

7. Mechanical Outline Dimension

Preliminary

It will be attached with PDF file

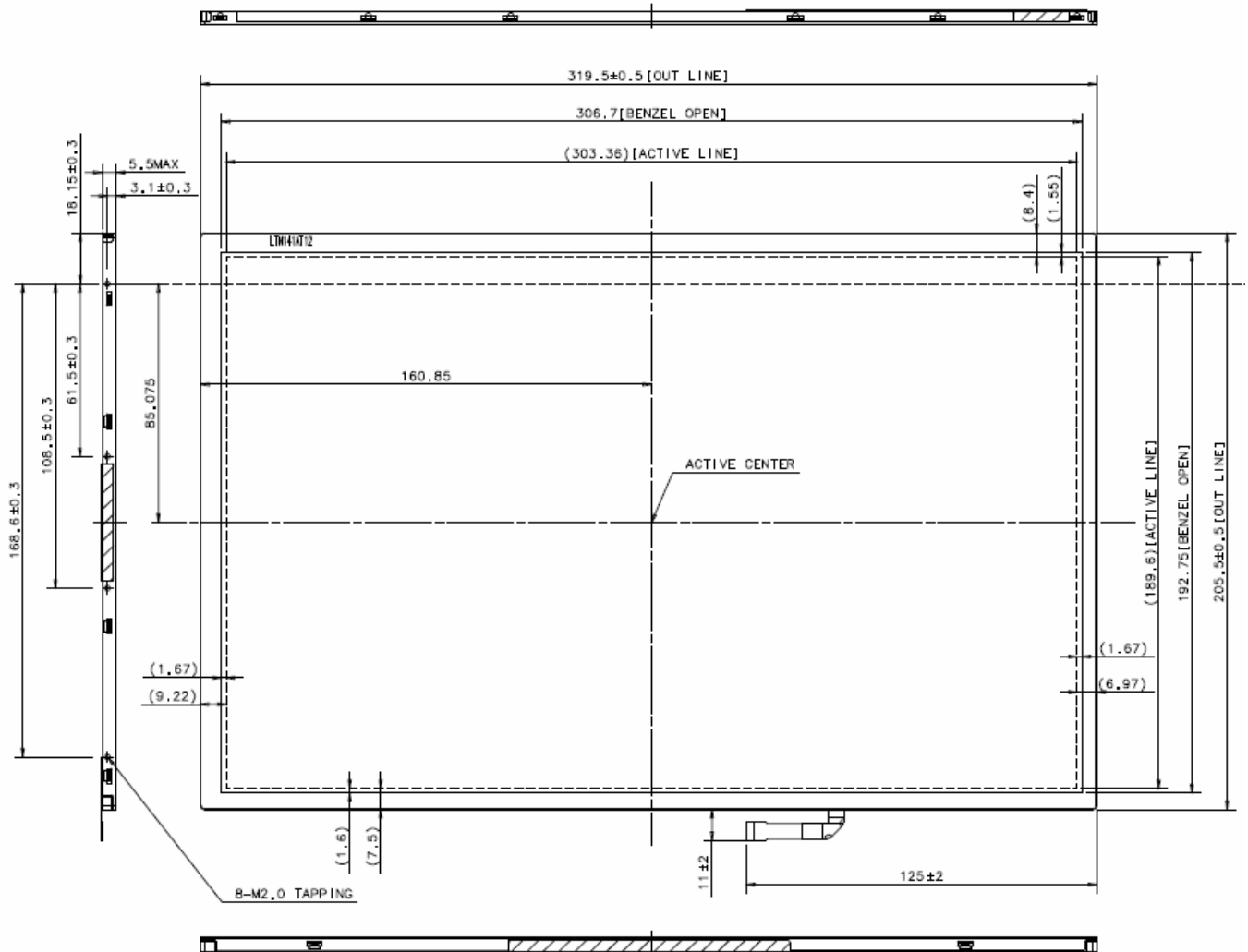

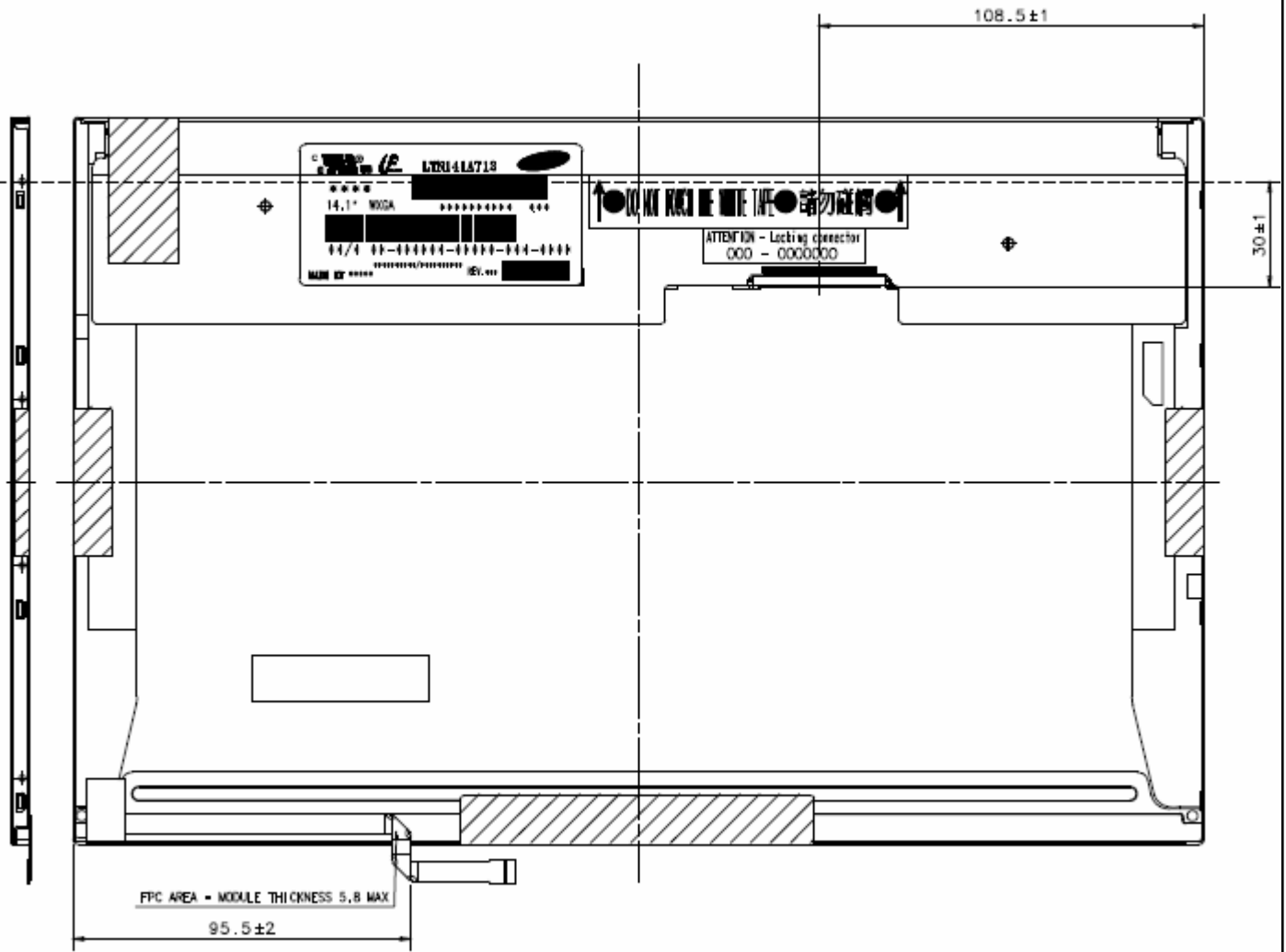

8. PACKING

1. CARTON(Internal Package)

(1) Packing Form

Corrugated Cardboard box and Corrupad form as shock absorber

(2) Packing Method

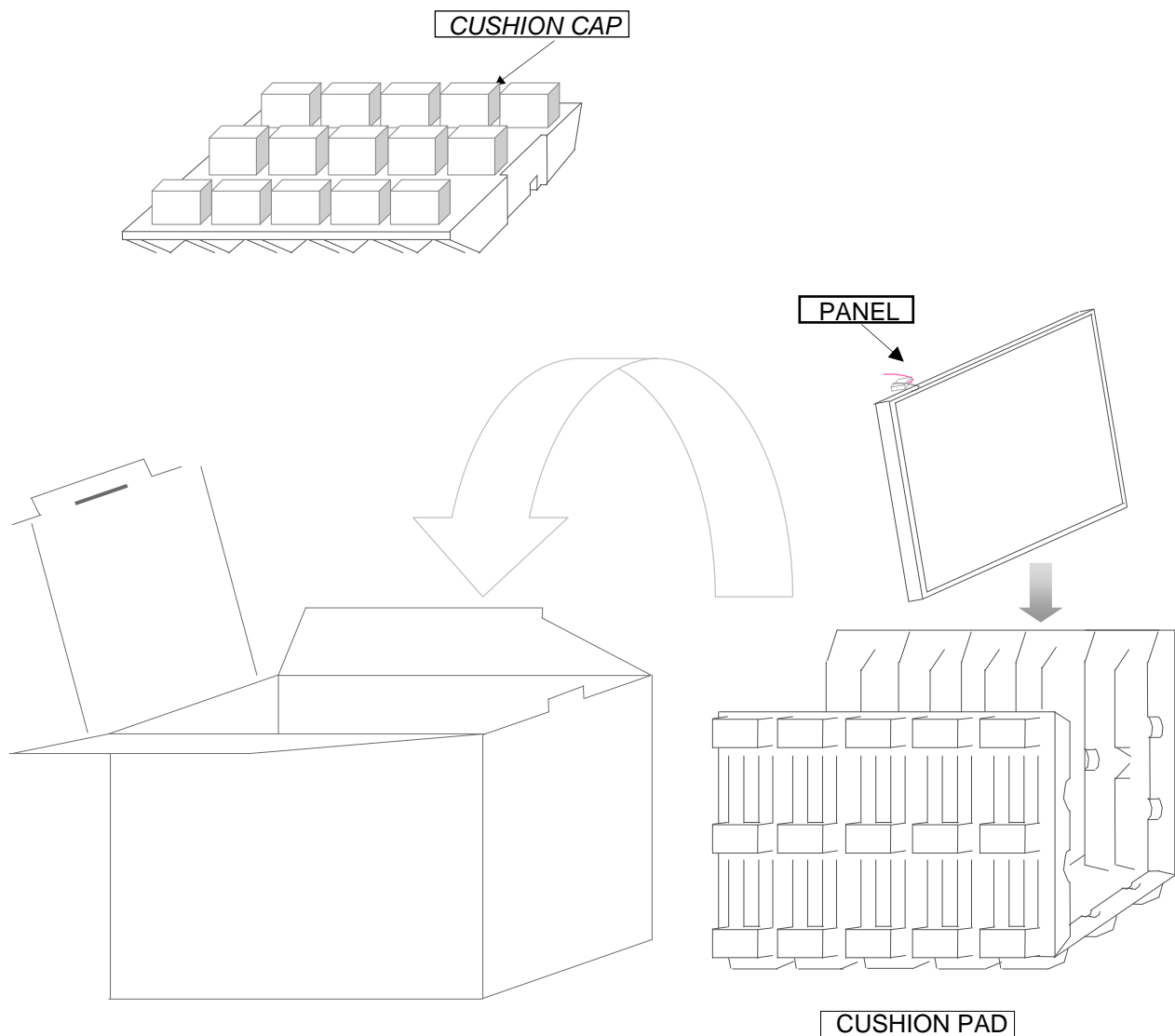

- Note 1) Total Weight : Approximately 5.5 kg
2) Acceptance number of piling : 10 sets
3) Carton size : 408(W) * 325(D) * 294(H)

No	Part name	Quantity
1	Static electric protective sack	10
2	Packing case (Inner box) included shock absorber	1 set
3	Pictorial marking	2 pcs
4	Carton	1 set

9. MARKINGS & OTHERS

A nameplate bearing followed by is affixed to a shipped product at the specified location on each product.

(1)Parts number : LTN141AT12

(2)Revision code : 3 letters

(3)Lot number : X X X X XXX XX X XXX

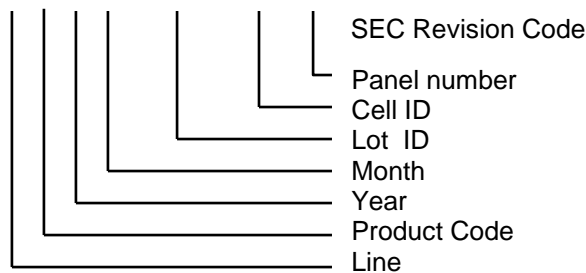

(4) Nameplate Indication

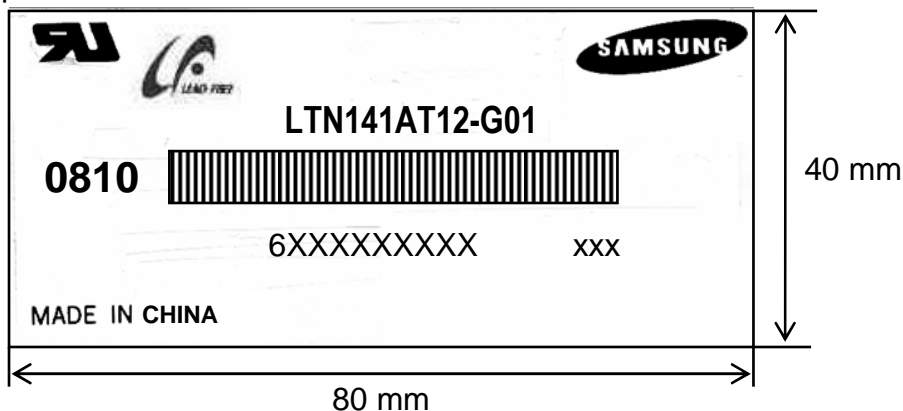

Parts name : LTN141AT12 G01
 Lot number : 6XXXXXXXXXX
 Inspected work week : 0810(2008 year, 10th week)
 Product Revision Code : XXX
 Production Site : CHINA(ESL)

(5) High voltage caution notice

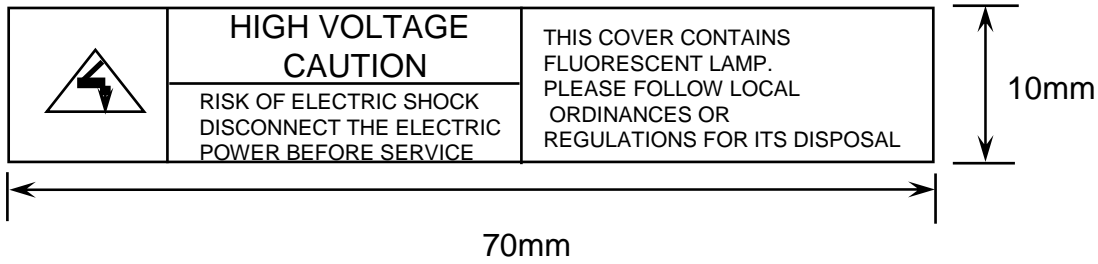

(6) Packing small box attach

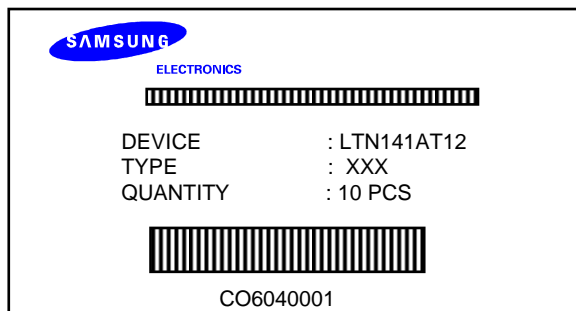

(7) Packing box Marking : Samsung TFT-LCD Brand Name



10. GENERAL PRECAUTIONS

Preliminary

1. Handling

- (a) When the module is assembled, It should be attached to the system firmly using every mounting holes. Be careful not to twist and bend the modules.
- (b) Refrain from strong mechanical shock and / or any force to the module. In addition to damage, this may cause improper operation or damage to the module and CCFT back-light.
- (c) Note that polarizers are very fragile and could be easily damaged. Do not press or scratch the surface harder than a HB pencil lead.
- (d) Wipe off water droplets or oil immediately. If you leave the droplets for a long time, Staining and discoloration may occur.
- (e) If the surface of the polarizer is dirty, clean it using some absorbent cotton or soft cloth.
- (f) The desirable cleaners are water, IPA (Isopropyl Alcohol) or Hexane. Do not use Ketone type materials(ex. Acetone), Ethyl alcohol, Toluene, Ethyl acid or Methyl chloride. It might permanent damage to the polarizer due to chemical reaction.
- (g) If the liquid crystal material leaks from the panel, it should be kept away from the eyes or mouth . In case of contact with hands, legs or clothes, it must be washed away thoroughly with soap.
- (h) Protect the module from static , it may cause damage to the C-MOS Gate Array IC.
- (i) Use fingerstalls with soft gloves in order to keep display clean during the incoming inspection and assembly process.
- (j) Do not disassemble the module.
- (k) Do not pull or fold the lamp wire.
- (l) Do not adjust the variable resistor which is located on the back side.
- (m) Protection film for polarizer on the module shall be slowly peeled off just before use so that the electrostatic charge can be minimized.
- (n) Pins of I/F connector shall not be touched directly with bare hands.

2. STORAGE

- (a) Do not leave the module in high temperature, and high humidity for a long time.
It is highly recommended to store the module with temperature from 0 to 35 °C and relative humidity of less than 70%.
- (b) Do not store the TFT-LCD module in direct sunlight.
- (c) The module shall be stored in a dark place. It is prohibited to apply sunlight or fluorescent light during the store.

3. OPERATION

- (a) Do not connect, disconnect the module in the “ Power On” condition.
- (b) Power supply should always be turned on/off by following item 6.3
“ Power on/off sequence “.
- (c) Module has high frequency circuits. Sufficient suppression to the electromagnetic interference shall be done by system manufacturers. Grounding and shielding methods may be important to minimize the interference.
- (d) The cable between the back-light connector and its inverter power supply shall be a minimized length and be connected directly . The longer cable between the back-light and the inverter may cause lower luminance of lamp(CCFT) and may require higher startup voltage (Vs).
- (e) The standard limited warranty is only applicable when the module is used for general notebook applications. If used for purposes other than as specified, SEC is not to be held reliable for the defective operations. It is strongly recommended to contact SEC to find out fitness for a particular purpose.

4. OTHERS

- (a) Ultra-violet ray filter is necessary for outdoor operation.
- (b) Avoid condensation of water. It may result in improper operation or disconnection of electrode.
- (c) Do not exceed the absolute maximum rating value. (the supply voltage variation, input voltage variation, variation in part contents and environmental temperature, so on)
Otherwise the module may be damaged.
- (d) If the module displays the same pattern continuously for a long period of time, it can be the situation when the image “sticks” to the screen.
- (e) This module has its circuitry PCB's on the rear side and should be handled carefully in order not to be stressed.