

mass integrated

global part distribution • product lifecycle partner
excess inventory management • value-ad service provider



Data sheet provided by Mass Integrated

massintegrated.com • displayalliance.com

Please call +1.978.465.6190
Email: sales@massintegrated.com



ISO 9001: 2008

Mass Integrated complies with all DMCA takedown notices. Please send a formal DMCA Takedown Notice to Mass Integrated Systems, Inc. • 18 Henry Graf Jr. Road, Unit 1 • Newburyport, MA 01950.

SAMSUNG

ELECTRONICS

Product Information



Product Information

SAMSUNG TFT-LCD

MODEL NO. : LTN150XG-L08

LCD Product Planning Group 1, Marketing Team

Samsung Electronics Co . , LTD.



SAMSUNG TFT-LCD

CONTENTS

General Description	----- (3)
1. Electrical Absolute Ratings	----- (4)
2. Optical Characteristics	----- (5)
3. Electrical Characteristics	----- (6)
3.1 TFT LCD Module	
3.2 Backlight Unit	
4. Block Diagram	----- (7)
4.1 TFT LCD Module	
4.2 Backlight Unit	
5. Input Terminal Pin Assignment	----- (8)
5.1 Input Signal & Power	
5.2 Backlight Unit	
5.3 Timing Diagrams of LVDS For Transmitting	
6. Interface Timing	----- (10)
6.1 Timing Parameters	
6.2 Timing Diagrams of interface Signal	
6.3 Power ON/OFF Sequence	
7. Outline Dimension	----- (12)

GENERAL DESCRIPTION

DESCRIPTION

LTN150XG-L08 is a color active matrix TFT (Thin Film Transistor) liquid crystal display (LCD) that uses amorphous silicon TFT as a switching devices. This model is composed of a TFT LCD panel, a driver circuit and a backlight system. The resolution of a 15.0" contains 1,024 x 768 pixels and can display up to 262,144 colors. 6 O'clock direction is the Optimum viewing angle.

FEATURES

- Thin and light weight
- High contrast ratio
- XGA (1024x768 pixels) resolution
- Low power consumption
- DE (Data enable) only mode.
- 3.3V LVDS Interface
- On board EDID chip, SPWG-B style
- Pb-free product

APPLICATIONS

- Notebook PC
- If the usage of this product is not for PC application, but for others, please contact SEC

GENERAL INFORMATION

Item	Specification	Unit	Note
Display area	304.128(H)X228.096(V) (15.0"diagonal)	mm	
Driver element	a-si TFT active matrix		
Display colors	262,144		
Number of pixel	1024 x 768 (XGA)	pixel	
Pixel arrangement	RGB vertical stripe		
Pixel pitch	0.297(H) x 0.297(V)	mm	
Display Mode	Normally white(TN)		
Surface treatment	Haze 40, Hard-Coating 2H ,ARC150T		

MECHANICAL INFORMATION

ITEM		MIN.	TYP.	MAX.	NOTE
Module size (mm)	Horizontal (H)	316.8	317.3	317.8	
	Vertical (V)	241.4	242.0	242.6	
	Depth (D)	-	5.7	6.0	(1)
Weight(g)		-	510	530	

Note (1) Measurement condition of outline dimension
. Equipment : Vernier Calipers
. Push Force : 500g · f (minimum)

1. ELECTRICAL ABSOLUTE RATINGS**(1) TFT LCD MODULE**
 $V_{DD} = 3.3V, V_{SS} = GND = 0V$

Item	Symbol	Min.	Max.	Unit	Note
Power Supply Voltage	V_{DD}	$V_{DD} - 0.3$	$V_{DD} + 0.3$	V	(1)
Logic Input Voltage	V_{IN}	$V_{DD} - 0.3$	$V_{DD} + 0.3$	V	(1)

Note (1) Within T_a ($25 \pm 2 \text{ }^\circ\text{C}$)

(2) BACK-LIGHT UNIT
 $T_a = 25 \pm 2 \text{ }^\circ\text{C}$

Item	Symbol	Min.	Max.	Unit	Note
Lamp Current	I_L	2.0	7.0	mArms	(1)
Lamp frequency	F_L	40	80	kHz	(1)

Note 1) Permanent damage to the device may occur if maximum values are exceeded
Functional operation should be restricted to the conditions described under normal operating conditions.

2. OPTICAL CHARACTERISTICS

The following items are measured under stable conditions. The optical characteristics should be measured in a dark room or equivalent state

Measuring equipment : TOPCON BM-5A

* Ta = 25±2°C , Vcc=3.3V, fv= 60Hz, fdCLK=65MHz, IL= 6.0mA

Item		Symbol	Condition	Min.	Typ.	Max	Unit
Contrast Ratio (5 Points)		CR	Normal Viewing Angle $\phi = 0$ $\theta = 0$	-	300	-	-
Response Time at Ta (Rising + Falling)		T _R +T _F		-	10	20	msec
Average Luminance of White (5 Points)		Y _{L,AVE}		170	200	-	cd/m ²
Color Chromaticity (CIE)	Red	R _X		0.539	0.569	0.599	-
		R _Y		0.302	0.332	0.362	
	Green	G _X		0.282	0.312	0.342	
		G _Y		0.514	0.544	0.574	
	Blue	B _X		0.119	0.149	0.179	
		B _Y		0.102	0.132	0.162	
	White	W _X		0.285	0.313	0.341	
		W _Y	0.299	0.329	0.359		
Viewing Angle	Hor.	θ_L	CR ≥ 10	40	45	Degrees	
		θ_H		40	45		
	Ver.	ϕ_H		10	20		
		ϕ_L		40	45		
13 Points White Variation		δ_L		50	-	-	%

3. ELECTRICAL CHARACTERISTICS

3.1 TFT LCD MODULE

Ta = 25 ± 2°C

Item		Symbol	Min.	Typ.	Max.	Unit	Note
Voltage of Power Supply		V _{DD}	3.0	3.3	3.6	V	
Differential Input Voltage for LVDS Receiver Threshold	High	V _{IH}	-	-	+100	mV	
	Low	V _{IL}	-100	-	-	mV	
Vsync Frequency		f _v	-	60	-	Hz	
Hsync Frequency		f _H	-	48.36	-	KHz	
Main Frequency		f _{DCLK}	-	65	-	MHz	
Rush Current		I _{RUSH}	-	-	1.5	A	
Current of Power Supply	White	I _{DD}	-	330	-	mA	
	Mosaic		-	360	-	mA	
	Max Pattern		-	480	510	mA	

3.2 BACK-LIGHT UNIT

The backlight system is an edge - lighting type with a single CCFL (Cold Cathode Fluorescent Lamp).
The characteristics of a single lamp are shown in the following tables.

Ta=25 ± 2 °C

Item	Symbol	Min.	Typ.	Max.	Unit	Note
Lamp Current	I _L	3.0	6.0	6.5	mArms	
Lamp Voltage	V _L		660	-	Vrms	I _L =6.0mA
Frequency	f _L	50	60	65	KHz	
Power Consumption	P _L		3.96		W	I _L =6.0mA
Operating Life Time	Hr	10,000			Hour	
Startup Voltage	V _s	-	-	1200	Vrms	25°C
				1500	Vrms	0°C
Lamp startup time		-	-	1.0	sec	

4. BLOCK DIAGRAM

4.1 TFT LCD Module

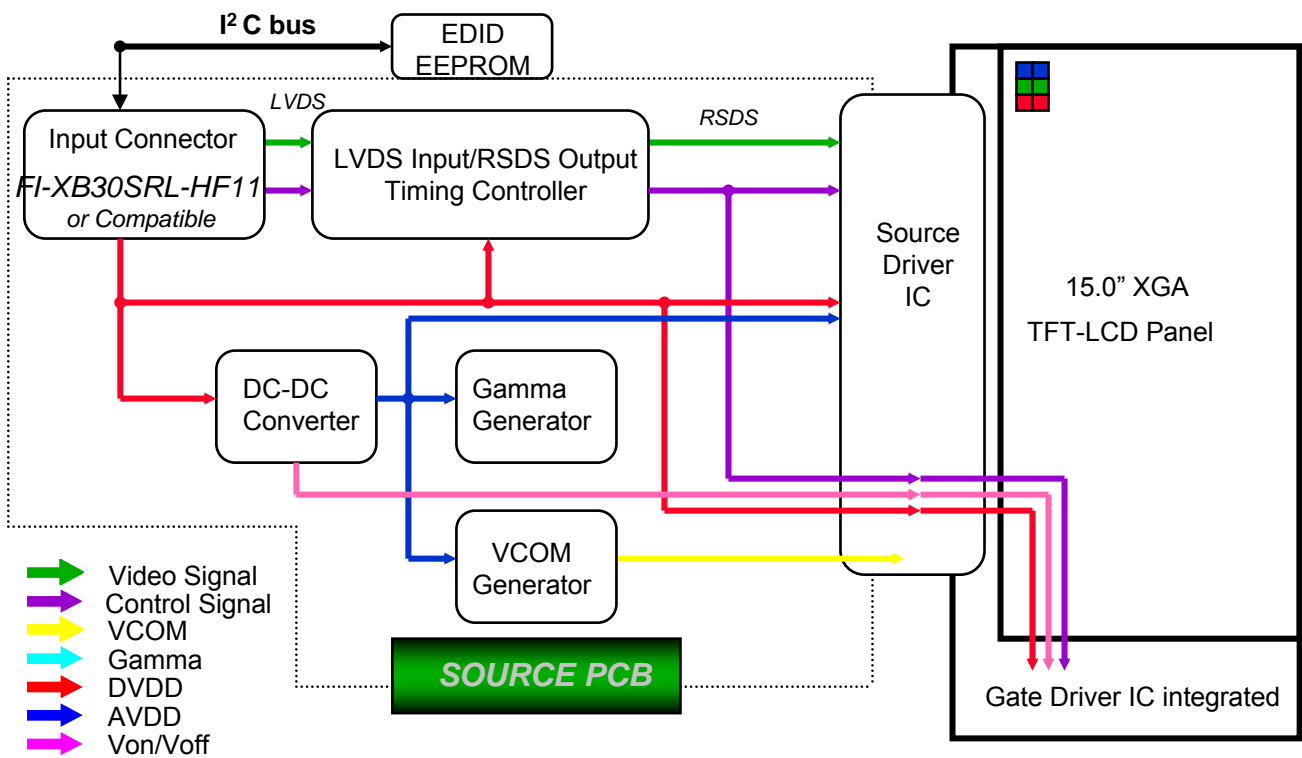

4.2 BACKLIGHT UNIT

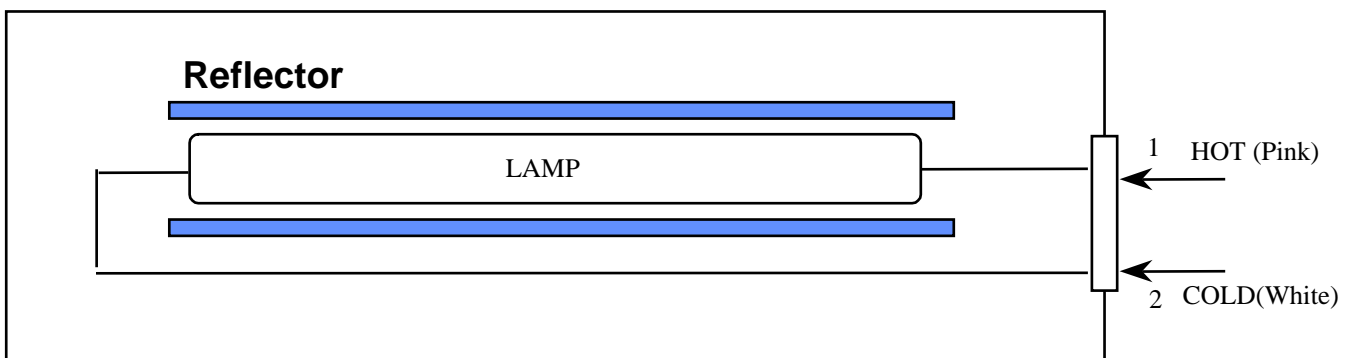

Note) The output of the inverter may change according to the material of the reflector.

5. INPUT TERMINAL PIN ASSIGNMENT

5.1. Input Signal & Power LVDS, Connector : JAE, FI-XB30SRL-HF11 or Compatible
Mating Connector : JAE, FI-X30M or Compatible

PIN NO	SYMBOL	FUNCTION	POLARITY	REMARK
1	Vss	Ground		
2	VDD	POWER SUPPLY +3.3V		
3	VDD	POWER SUPPLY +3.3V		
4	VEEDID	DDC 3.3V Power		
5	BIST	Panel BIST control		
6	CLKEDID	DDC Clock		
7	DATAEDID	DDC data		
8	O_RxIN0-	LVDS Differential Data INPUT (Odd R0-R5,G0)	Negative	
9	O_RxIN0+	LVDS Differential Data INPUT (Odd R0-R5,G0)	Positive	
10	GND	Ground		
11	O_RxIN1-	LVDS Differential Data INPUT (Odd G1-G5,B0-B1)	Negative	
12	O_RxIN1+	LVDS Differential Data INPUT (Odd G1-G5,B0-B1)	Positive	
13	GND	Ground		
14	O_RxIN2-	LVDS Differential Data INPUT (Odd B2-B5,Sync,DE)	Negative	
15	O_RxIN2+	LVDS Differential Data INPUT (Odd B2-B5,Sync,DE)	Positive	
16	GND	Ground		
17	O_RxCLK-	LVDS Differential Data INPUT (Odd Clock)	Negative	
18	O_RxCLK+	LVDS Differential Data INPUT (Odd Clock)	Positive	
19	GND	Ground		
20	NC	NC		
21	NC	NC		
22	NC	NC		
23	NC	NC		
24	NC	NC		
25	NC	NC		
26	NC	NC		
27	NC	NC		
28	NC	NC		
29	NC	NC		
30	NC	NC		

5.2 BACK LIGHT UNIT

Connector : JST BHSR - 02VS -1 or Compatible

Pin NO.	Symbol	Color	Function
1	HOT	Pink	High Voltage
2	COLD	White	Low Voltage

5.3 Timing Diagrams of LVDS For Transmission

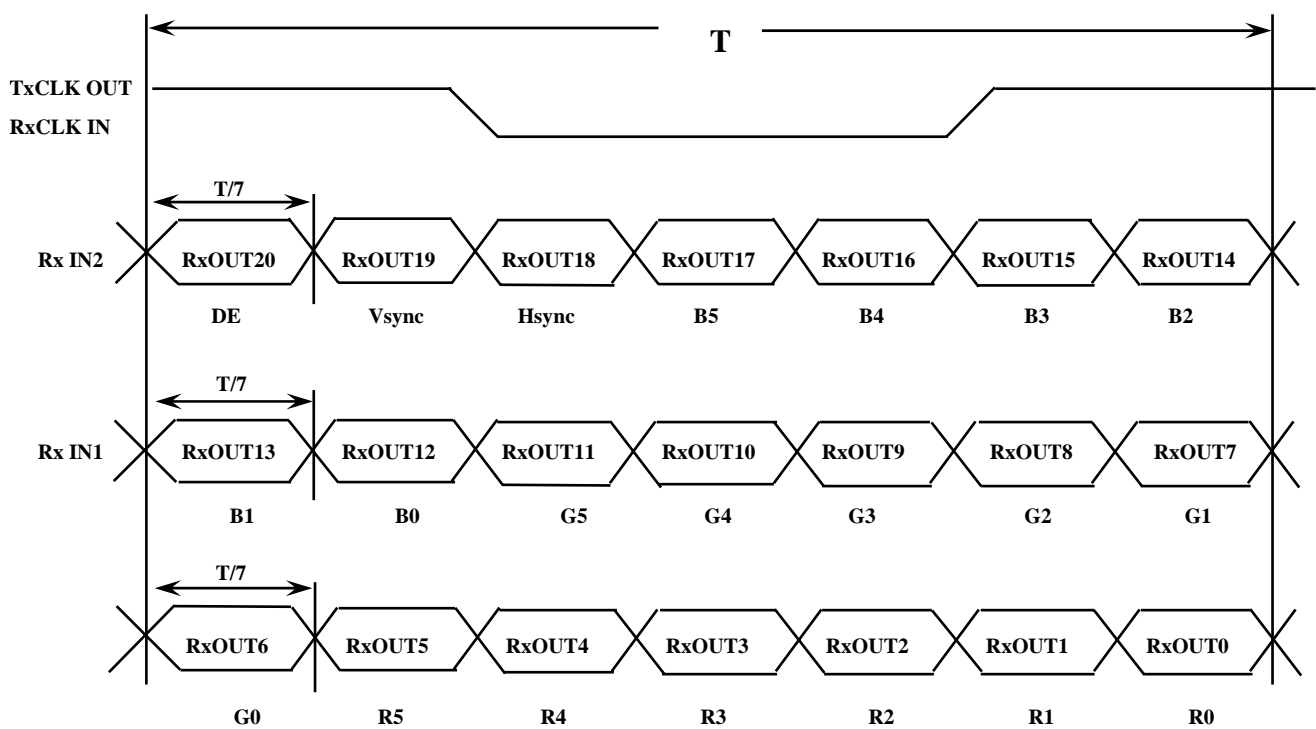

6. INTERFACE TIMING

6.1 Timing Parameters

Signal	Item	Symbol	Min	Typ	Max	Unit	Note
Frame Frequency	Cycle	T_V	-	806	-	Line	
Vertical Active Display time	Display period	T_{VD}	-	768	-	Line	
One line Scanning time	Cycle	T_H	-	1344	-	Clock	
Horizontal Active Display time	Display period	T_{HD}	-	1024	-	Clock	

6.2 Timing diagrams of interface signal

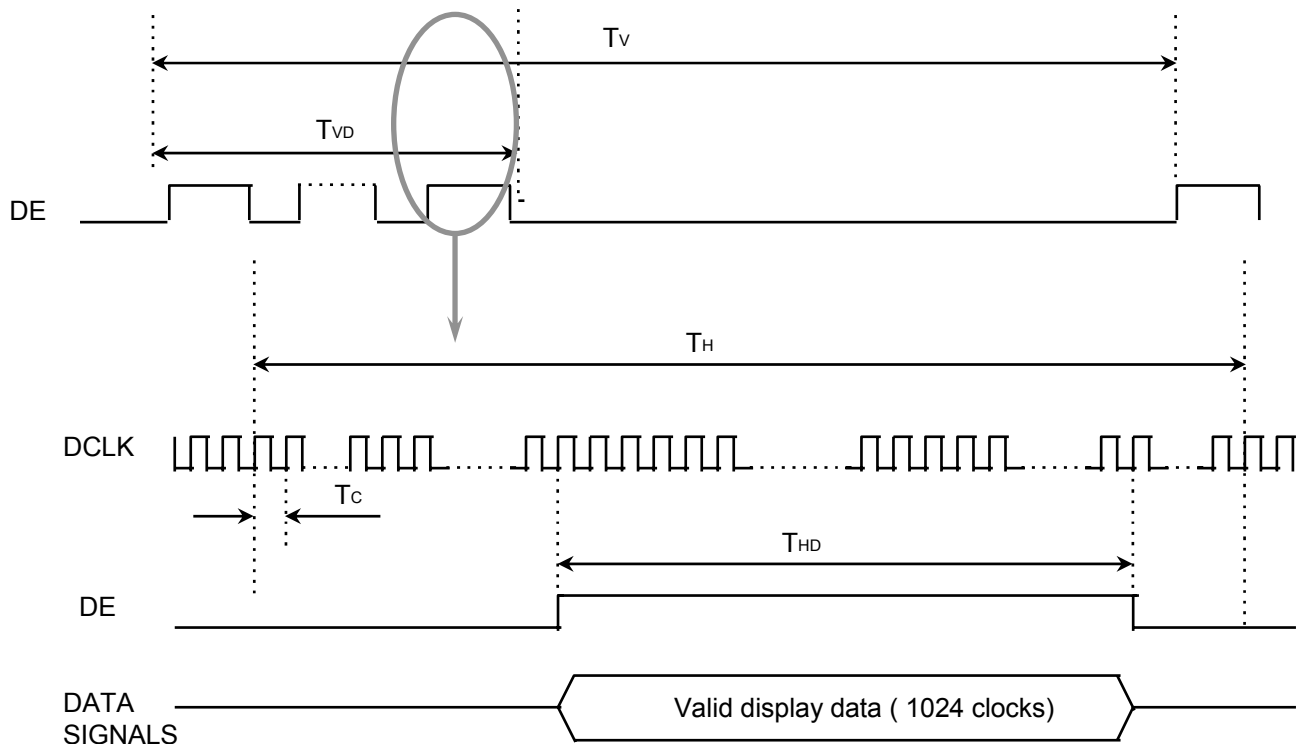

6.3 Power ON/OFF Sequence

: To prevent a latch-up or DC operation of the LCD module, the power on/off sequence should be as the diagram below.

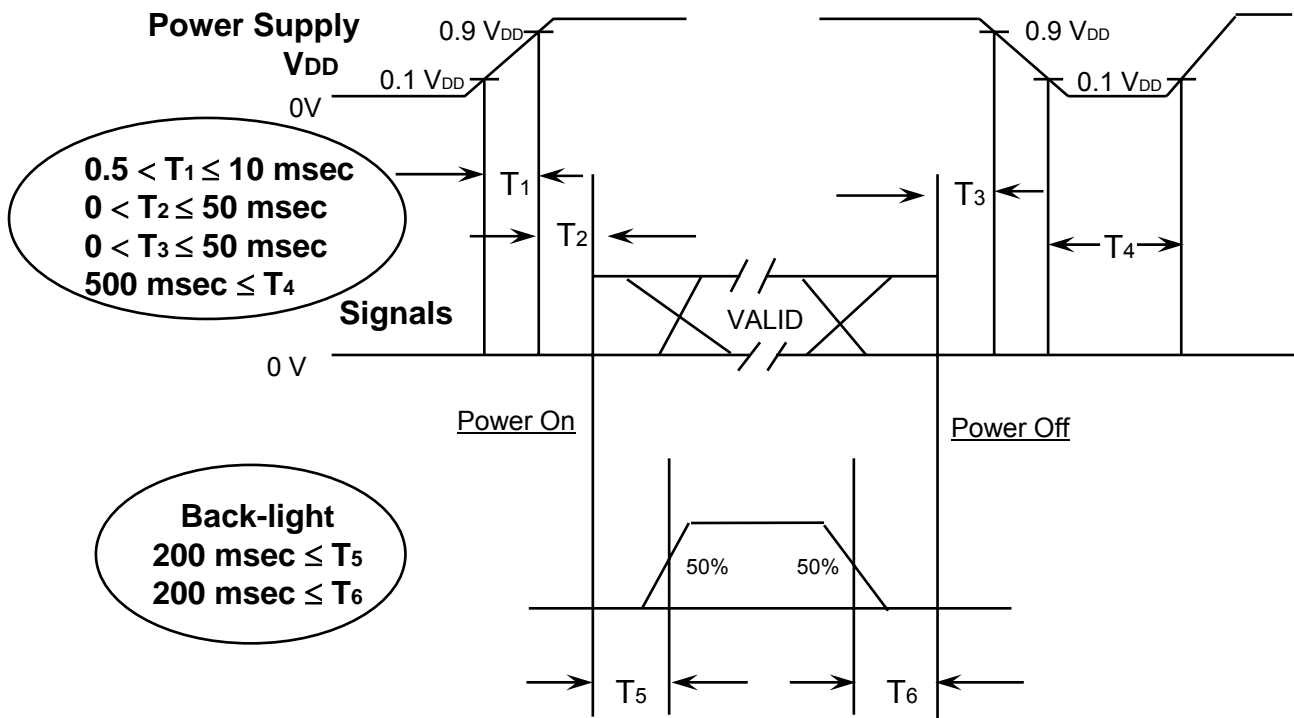

Power ON/OFF Sequence

- T1 : Vdd rising time from 10% to 90%
- T2 : The time from Vdd to valid data at power ON.
- T3 : The time from valid data off to Vdd off at power Off.
- T4 : Vdd off time for Windows restart
- T5 : The time from valid data to B/L enable at power ON.
- T6 : The time from valid data off to B/L disable at power Off.

NOTE.

- (1) The supply voltage of the external system for the module input should be the same as the definition of VDD.
- (2) Apply the lamp voltage within the LCD operation range. When the back-light turns on before the LCD operation or the LCD turns off before the back-light turns off, the display may momentarily become white.
- (3) In case of VDD = off level, please keep the level of input signals on the low or keep a high impedance.
- (4) T4 should be measured after the module has been fully discharged between power off and on period.
- (5) Interface signal shall not be kept at high impedance when the power is on.

7. MECHANICAL OUTLINE DIMENSION

Product Information

[Refer to the next page]

Doc.No.	LTN150XG-L08	ISSUED DATE	11/Nov/2006	Page	12 / 13
----------------	--------------	--------------------	-------------	-------------	---------

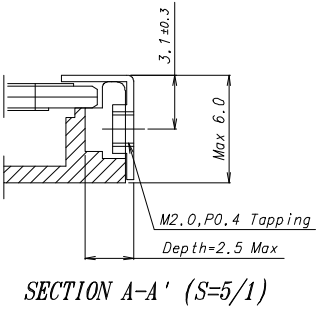
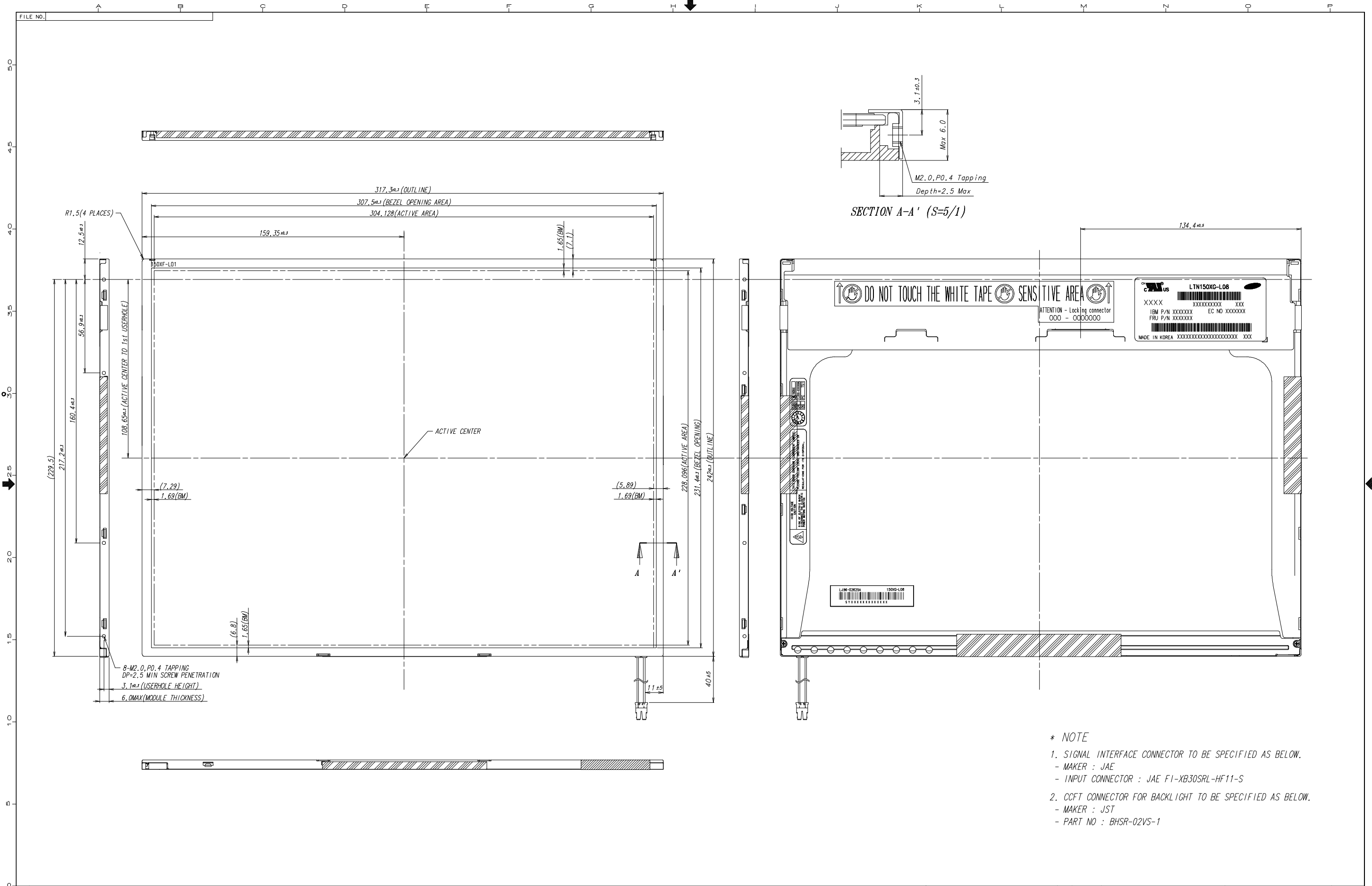

- * NOTE**
- SIGNAL INTERFACE CONNECTOR TO BE SPECIFIED AS BELOW.
 - MAKER : JAE
 - INPUT CONNECTOR : JAE FI-XB30SRL-HF11-S
 - CCFT CONNECTOR FOR BACKLIGHT TO BE SPECIFIED AS BELOW.
 - MAKER : JST
 - PART NO : BHSR-02VS-1

GENERAL TOLERANCE				REV	DATE	DESCRIPTION OF REVISION				REASON		CHK'D BY
STEP	LEVEL 1	LEVEL 2	LEVEL 3	UNIT	DRA'N BY	DES'D BY	CHK'D BY	APP'D BY	MODEL NAME	PART/SHEET NAME	OUTLINE DIMENSION	SHEET 1/1
0 < X ≤ 4	±0.05	±0.1	±0.2	SCALE	JUNU.YOU	T.G.KANG	D.C.YANG		LTN150XG-L08			
4 < X ≤ 16	±0.08	±0.15	±0.3	TOLERANCE	2005.11.10	2005.11.10	2005.11.10					
16 < X ≤ 64	±0.12	±0.25	±0.5	LEVEL 3								
64 < X ≤ 256	±0.25	±0.4	±0.8	SAMSUNG ELECTRONICS								