

# mass integrated

global part distribution • product lifecycle partner  
excess inventory management • value-ad service provider



Data sheet provided by Mass Integrated

[massintegrated.com](http://massintegrated.com) • [displayalliance.com](http://displayalliance.com)

Please call +1.978.465.6190  
Email: [sales@massintegrated.com](mailto:sales@massintegrated.com)



ISO 9001: 2008

Mass Integrated complies with all DMCA takedown notices. Please send a formal DMCA Takedown Notice to Mass Integrated Systems, Inc. • 18 Henry Graf Jr. Road, Unit 1 • Newburyport, MA 01950.



ELECTRONICS

Approval



TO :  
DATE : Oct. 06. 2009

**SAMSUNG TFT-LCD**  
**MODEL NO : LTN156AT02-A04**

NOTE : Extension code [ -A ]  
→ LTN156AT02-**A04**  
Surface type [ Glare

*The information described in this SPEC is preliminary and can be changed without prior notice.*

**Application engineering part, DS Solution**  
**Samsung Electronics Co., Ltd.**



**Samsung Secret**

**CONTENTS**

Revision History	----- ( 3 )
General Description	----- ( 4 )
1. Absolute Maximum Ratings	----- ( 5 )
1.1 Absolute Ratings of environment	
1.2 Electrical Absolute Ratings	
2. Optical Characteristics	----- ( 7 )
3. Electrical Characteristics	----- ( 10 )
3.1 TFT LCD Module	
3.2 Backlight Unit	
3.3 LED Driver	
4. Block Diagram	----- ( 13 )
4.1 TFT LCD Module	
5. Input Terminal Pin Assignment	----- ( 14 )
5.1 Input Signal & Power	
5.2 LVDS Interface	
5.3 Timing Diagrams of LVDS For Transmitting	
5.4 Input Signals, Basic Display Colors and Gray Scale of Each Color.	
5.5 Pixel format	
6. Interface Timing	----- ( 19 )
6.1 Timing Parameters	
6.2 Timing Diagrams of interface Signal	
6.3 Power ON/OFF Sequence	
7. Outline Dimension	----- ( 21 )
8. Packing	----- ( 23 )
9. Markings & Others	----- ( 24 )
10. General Precautions	----- ( 26 )
11. EDID	----- ( 28 )

# REVISION HISTORY

**Confidential**

Approval

Date	Revision No.	Page	Summary
Oct. 6, 2009	A00	All	The preliminary specification of LTN156AT02-A04 was issued first. New revision code 'A04' was applied for FAB Line was changed to 'L6' from 'A5'

**Samsung Secret**

<b>Doc.No.</b>	LTN156AT02-A04	<b>Rev.No</b>	04-A00-G-091006	<b>Page</b>	3 / 30
----------------	----------------	---------------	-----------------	-------------	--------

## GENERAL DESCRIPTION

### DESCRIPTION

LTN156AT02-A04 is a color active matrix TFT (Thin Film Transistor) liquid crystal display (LCD) that uses amorphous silicon TFT as switching devices. This model is composed of a TFT LCD panel, a driver circuit and a backlight system. The resolution of a 15.6" contains 1366 x 768 pixels and can display up to 262,144 colors. 6 O'clock direction is the Optimum viewing angle.

### FEATURES

- Thin and light weight
- High contrast ratio, high aperture structure
- 1366 x 768 pixels resolution (16:9)
- Fast Response Time
- Low power consumption
- LED BLU Structure
- DE (Data enable) only mode
- 3.3V LVDS Interface
- On board EDID chip
- Pb-free product

### APPLICATIONS

- Notebook PC
- If the usage of this product is not for PC application, but for others, please contact SEC

## GENERAL INFORMATION

Item	Specification	Unit	Note
Display area	344.232 (H) x 193.536 (V) (15.6"diagonal)	mm	
Driver element	a-Si TFT active matrix		
Display colors	262,144		
Number of pixel	1366 x 768	pixel	16 : 9
Pixel arrangement	RGB vertical stripe		
Pixel pitch	0.252 (H) x 0.252 (V) (TYP.)	mm	
Display Mode	Normally white		
Surface treatment	Haze 0, Hardness 3H		Glare

**Samsung Secret**

<b>Doc.No.</b>	LTN156AT02-A04	<b>Rev.No</b>	04-A00-G-091006	<b>Page</b>	4 / 30
----------------	----------------	---------------	-----------------	-------------	--------

**Mechanical Information**

Item		Min.	Typ.	Max.	Unit	Note
Module size	Horizontal (H)	358.8	359.3	359.8	mm	
	Vertical (V)	209.0	209.5	210	mm	
	Depth (D)	-	5.1	5.5	mm	(1)
Weight		-	430	450	g	

Note (1) Measurement condition of outline dimension  
 . Equipment : Vernier Calipers  
 . Push Force : 500g · f (minimum)

**1. ABSOLUTE MAXIMUM RATINGS**

**1.1 ENVIRONMENTAL ABSOLUTE RATINGS**

Item	Symbol	Min.	Max.	Unit	Note
Storage temperate	TSTG	-20	60	°C	(1), (5)
Operating temperate (Temperature of glass surface)	TOPR	0	50	°C	(1), (5)
Shock ( non-operating )	Snop	-	240	G	(2), (4)
Vibration (non-operating)	Vnop	-	2.41	G	(3), (4)

Note (1) Temperature and relative humidity range are shown in the figure below.  
 95 % RH Max. ( $40\text{ }^{\circ}\text{C} \geq T_a$ )  
 Maximum wet - bulb temperature at  $39\text{ }^{\circ}\text{C}$  or less. ( $T_a > 40\text{ }^{\circ}\text{C}$ ) No condensation

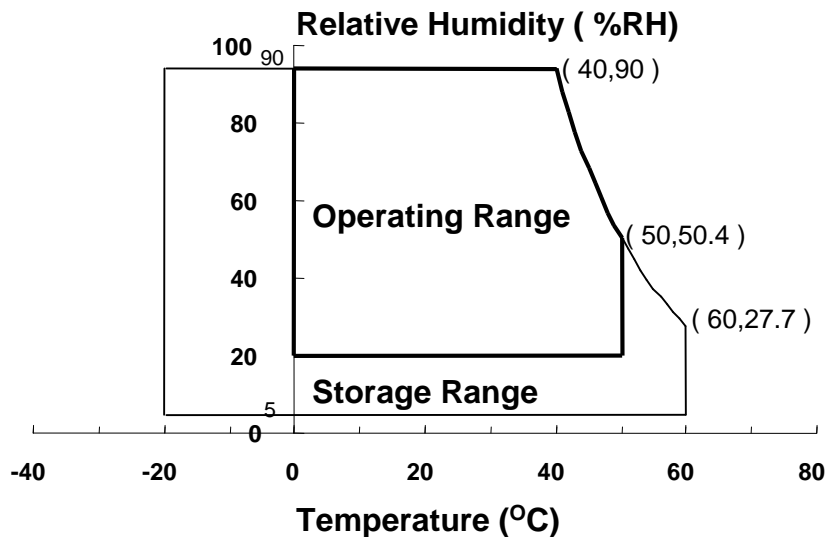

- (2) 2ms, half sine wave, one time for  $\pm X, \pm Y, \pm Z$ .
- (3) 5 - 500 Hz, random vibration, 30min for X, Y, Z.
- (4) At testing Vibration and Shock, the fixture in holding the Module to be tested have to be hard and rigid enough so that the Module would not be twisted or bent by the fixture.
- (5) If product is used for extended time excessively or exposed to high temperatures for extended time, there is a possibility of wide viewing angle film damage which could affect visual characteristics.

## 1.2 ELECTRICAL ABSOLUTE RATINGS

## (1) TFT LCD MODULE

 $V_{DD} = 3.3V, V_{SS} = GND = 0V$ 

Item	Symbol	Min.	Max.	Unit	Note
Power Supply Voltage	$V_{DD}$	$V_{DD} - 0.3$	$V_{DD} + 0.3$	V	(1)
Logic Input Voltage	$V_{DD}$	$V_{DD} - 0.3$	$V_{DD} + 0.3$	V	(1)

Note (1) Within  $T_a$  ( $25 \pm 2$  °C )

## 2. OPTICAL CHARACTERISTICS

The following items are measured under stable conditions. The optical characteristics should be measured in a dark room or equivalent state with the methods shown in Note (5).  
Measuring equipment : TOPCON SR-3

\* Ta = 25 ± 2 °C, V<sub>DD</sub>=3.3V, f<sub>V</sub>= 60Hz, f<sub>DCLK</sub> = 72.33MHz, I<sub>L</sub> = 20mA

Item	Symbol	Condition	Min.	Typ.	Max	Unit	Note	
Contrast Ratio (5 Points)	CR	Normal Viewing Angle φ = 0 θ = 0	400	500	-	-	(1), (2), (5)	
Response Time at Ta ( Rising + Falling )	T <sub>RT</sub>		-	8	16	msec	(1), (3)	
Average Luminance of White (5 Points)	Y <sub>L,AVE</sub>		190	220	-	cd/m <sup>2</sup>	I <sub>L</sub> =20mA (1), (4)	
Color Chromaticity ( CIE )	Red		R <sub>X</sub>	0.585	0.615	0.645	-	
			R <sub>Y</sub>	0.325	0.355	0.385		
	Green		G <sub>X</sub>	0.305	0.335	0.365		
			G <sub>Y</sub>	0.580	0.610	0.640		
	Blue		B <sub>X</sub>	0.120	0.150	0.180		
			B <sub>Y</sub>	0.070	0.100	0.130		
	White		W <sub>X</sub>	0.283	0.313	0.343		
		W <sub>Y</sub>	0.299	0.329	0.359			
Viewing Angle	Hor.	θ <sub>L</sub>	40	-	-	Degrees	(1), (5) SR-3	
		θ <sub>R</sub>	40	-	-			
	Ver.	φ <sub>H</sub>	15	-	-			
		φ <sub>L</sub>	30	-	-			
Color Gamut			-	60	-	%		
13 Points White Variation	δ <sub>L</sub>		-	-	1.7	-	(6)	

**Samsung Secret**

Note 1) Definition of Viewing Angle : Viewing angle range( $10 \leq C/R$ )

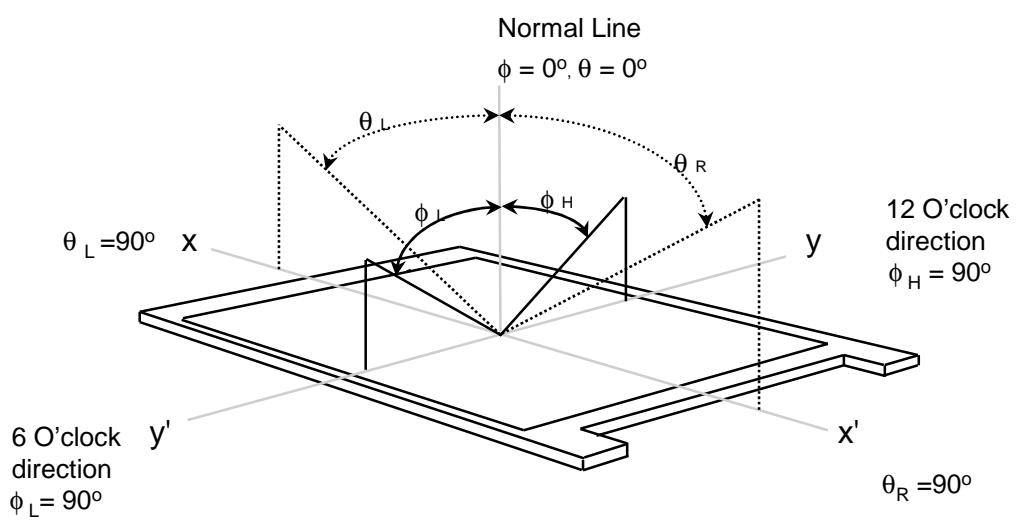

Note 2) Definition of Contrast Ratio (CR) : Ratio of gray max (Gmax) ,gray min (Gmin) at 5 points(4, 5, 7, 9, 10)

$$CR = \frac{CR(4) + CR(5) + CR(7) + CR(9) + CR(10)}{5}$$

Points : (4) , (5) , (7) , (9) , (10) at the figure of Note (6).

Note 3) Definition of Response time :

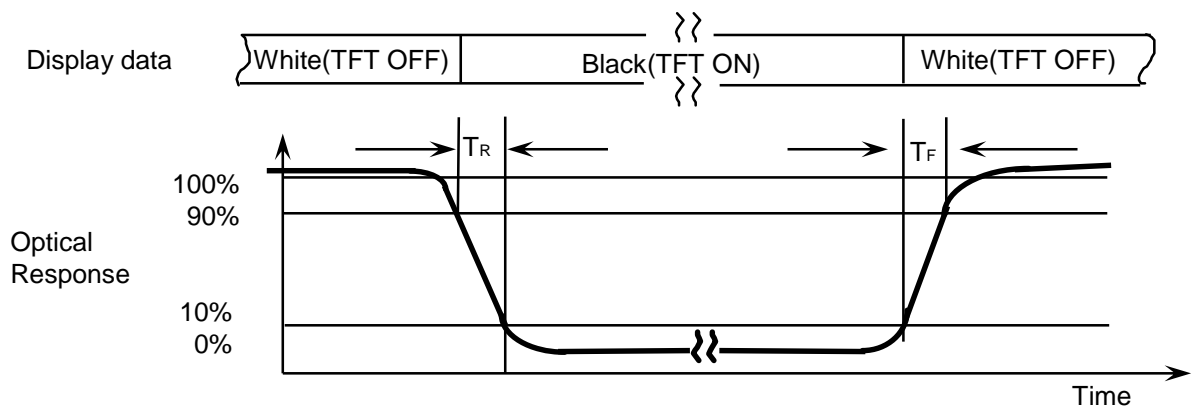

Note 4) Definition of Average Luminance of White : measure the luminance of white at 5 points.

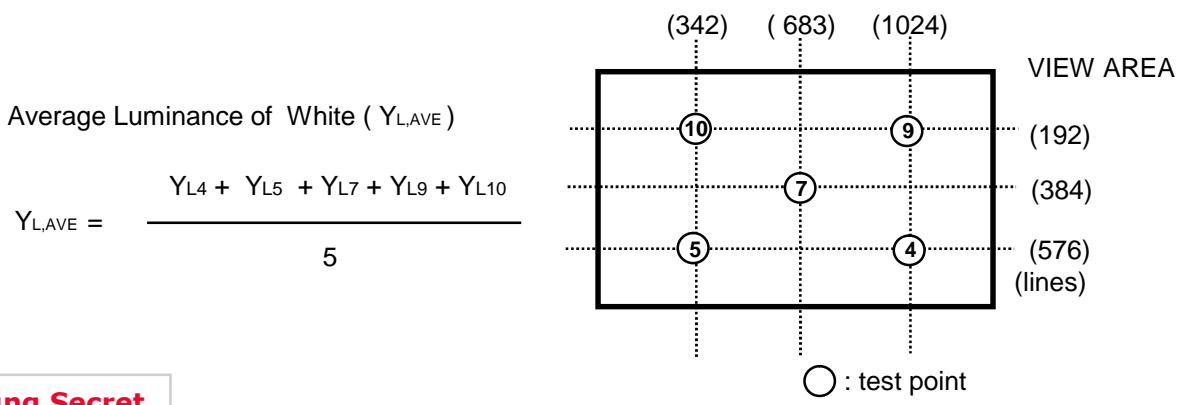

Note 5) After stabilizing and leaving the panel alone at a given temperature for 30 min , the measurement should be executed. Measurement should be executed in a stable, windless, and dark room. 30 min after lighting the backlight. This should be measured in the center of screen.  
 LED current : 20 mA  
 Environment condition :  $T_a = 25 \pm 2 \text{ } ^\circ\text{C}$

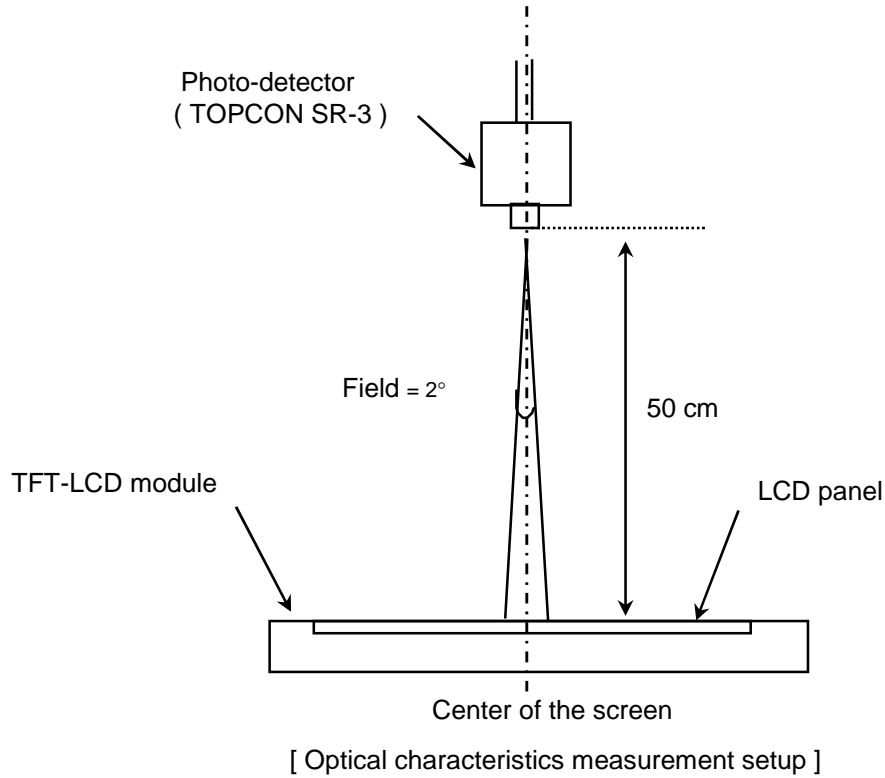

Note 6) Definition of 13 points white variation ( $\delta L$ ), [ ① ~ ⑬ ]

$$\delta L = \frac{\text{Maximum luminance of 13 points}}{\text{Minimum luminance of 13 points}}$$

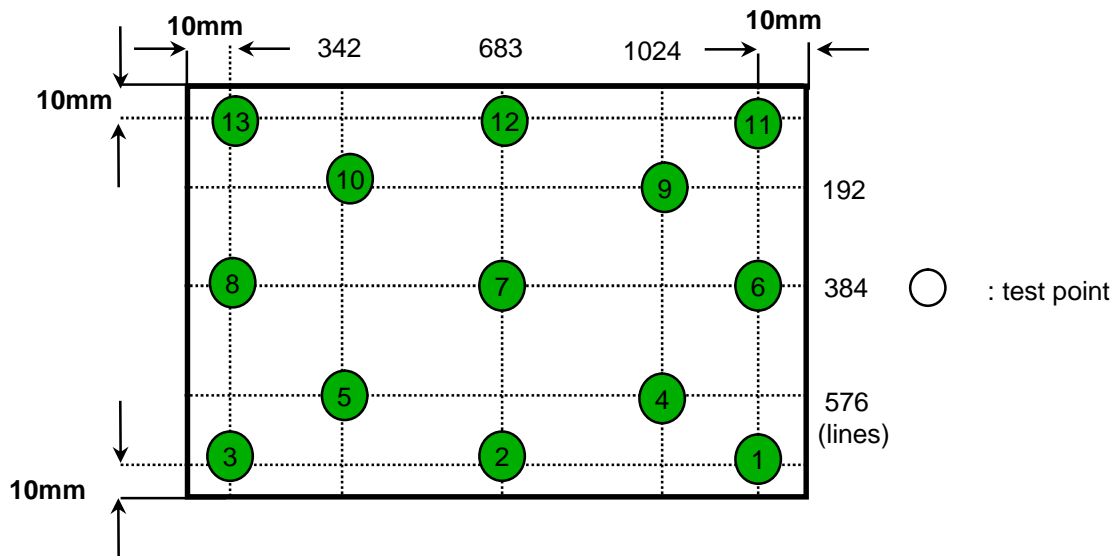

### 3. ELECTRICAL CHARACTERISTICS

#### 3.1 TFT LCD MODULE

Ta= 25 ± 2°C

Item	Symbol	Min.	Typ.	Max.	Unit	Note	
Voltage of Power Supply	V <sub>CC</sub>	3.0	3.3	3.6	V		
Differential Input Voltage for LVDS Receiver Threshold	High	V <sub>IH</sub>	-	-	+100	mV	V <sub>CM</sub> = +1.2V
	Low	V <sub>IL</sub>	-100	-	-	mV	
Vsync Frequency	f <sub>v</sub>	-	60	-	Hz		
Hsync Frequency	f <sub>H</sub>	-	47.4	-	KHz		
Main Frequency	f <sub>DCLK</sub>	-	72.33	80	MHz		
Rush Current	I <sub>RUSH</sub>	-	-	1.5	A	(4)	
Current of Power Supply	White	I <sub>DD</sub>	-	330	-	mA	(2),(3)*a
	Mosaic		-	470	-	mA	(2),(3)*b
	Black		-	650	700	mA	(2),(3)*c
	V-strip		-	500	-	mA	(2),(3)*c

Note (1) Display data pins and timing signal pins should be connected.( GND = 0V )

(2) f<sub>v</sub> = 60Hz, f<sub>DCLK</sub> = 72.33 MHz, V<sub>DD</sub> = 3.3V , DC Current.

(3) Power dissipation pattern

\*a) White Pattern

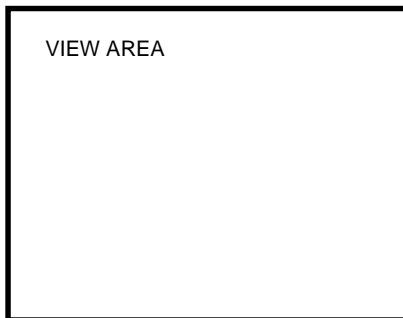

Display Brightest Gray Level →

Display Darkest Gray Level →

\*b) Mosaic Pattern

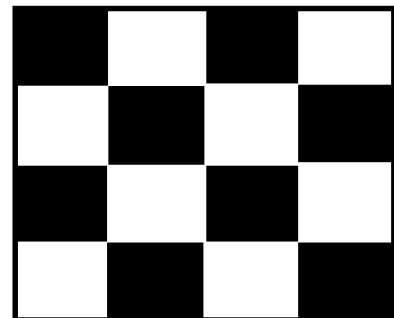

\*c) Black Pattern

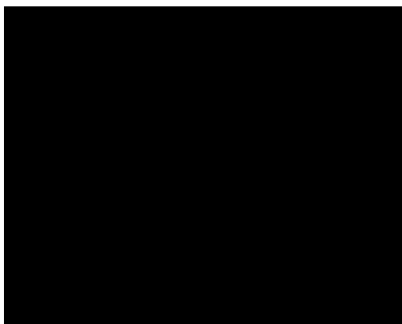

\*d) 1dot Vertical stripe pattern

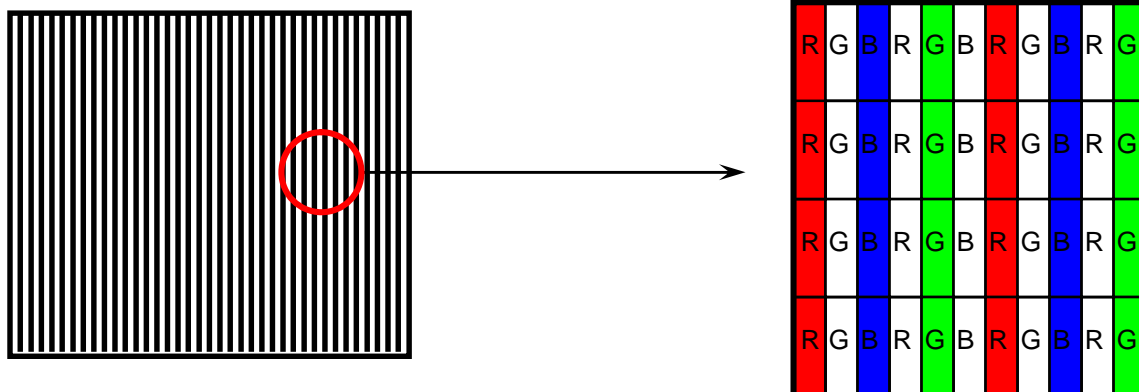

4) Rush current measurement condition ( $V_{CC}$  rising time is 470us)

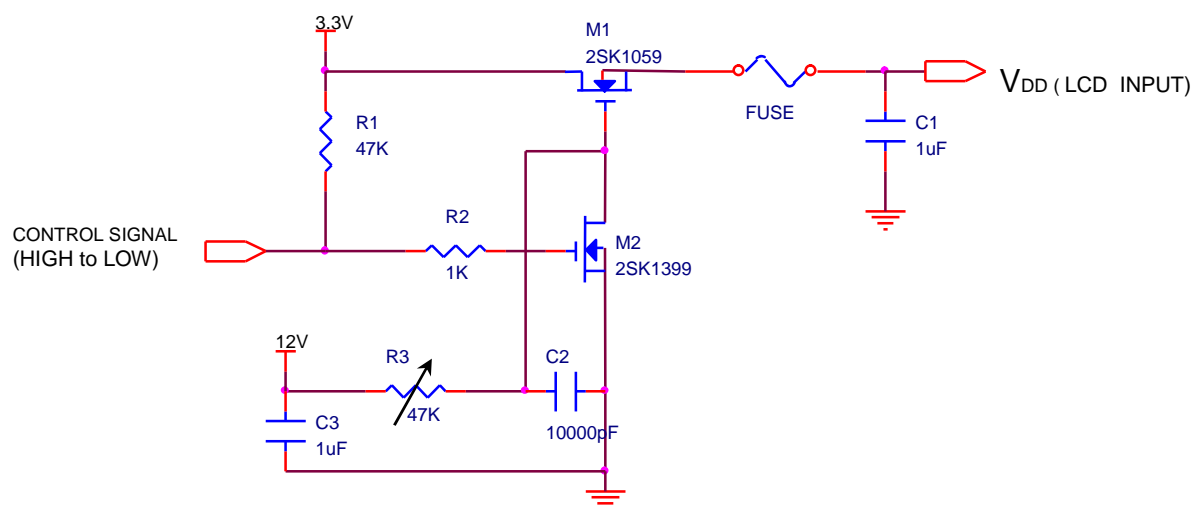

## 3.2 BACK-LIGHT UNIT

Ta= 25 ± 2 °C

Item	Symbol	Min.	Typ.	Max.	Unit	Note
LED Forward Current	IF	-	20	30	mA	
LED Forward Voltage	VF	-	3.2	-	V	
LED Array Voltage	VP	-	35.2	-	V	VF X 11 LEDs
Power Consumption	P	-	2.816	-	W	IF X VF X 44 LEDs (w/o Converter)

## 3.3 LED Driver

- On board LED Driver (Manufacturer : Richtek)

Ta= 25 ± 2 °C

Item	Symbol	Min.	Typ.	Max.	Unit	Note
Input Voltage	V <sub>in</sub>	7	12	30	V	
Operating Frequency	F <sub>o</sub>	840	1000	1160	KHz	600KHz possible
Duty ratio	D	10	-	100	%	PWM Freq. : 1kHz~10KHz
		5		100		200Hz~1KHz
PWM frequency	P <sub>PWM</sub>	-	1	10	KHz	

Note (1) Test Equipment : Fluke 45

(2) SEC guarantee PWM frequency from 0.2kHz to 10KHz

### 4. BLOCK DIAGRAM

#### 4.1 TFT LCD Module

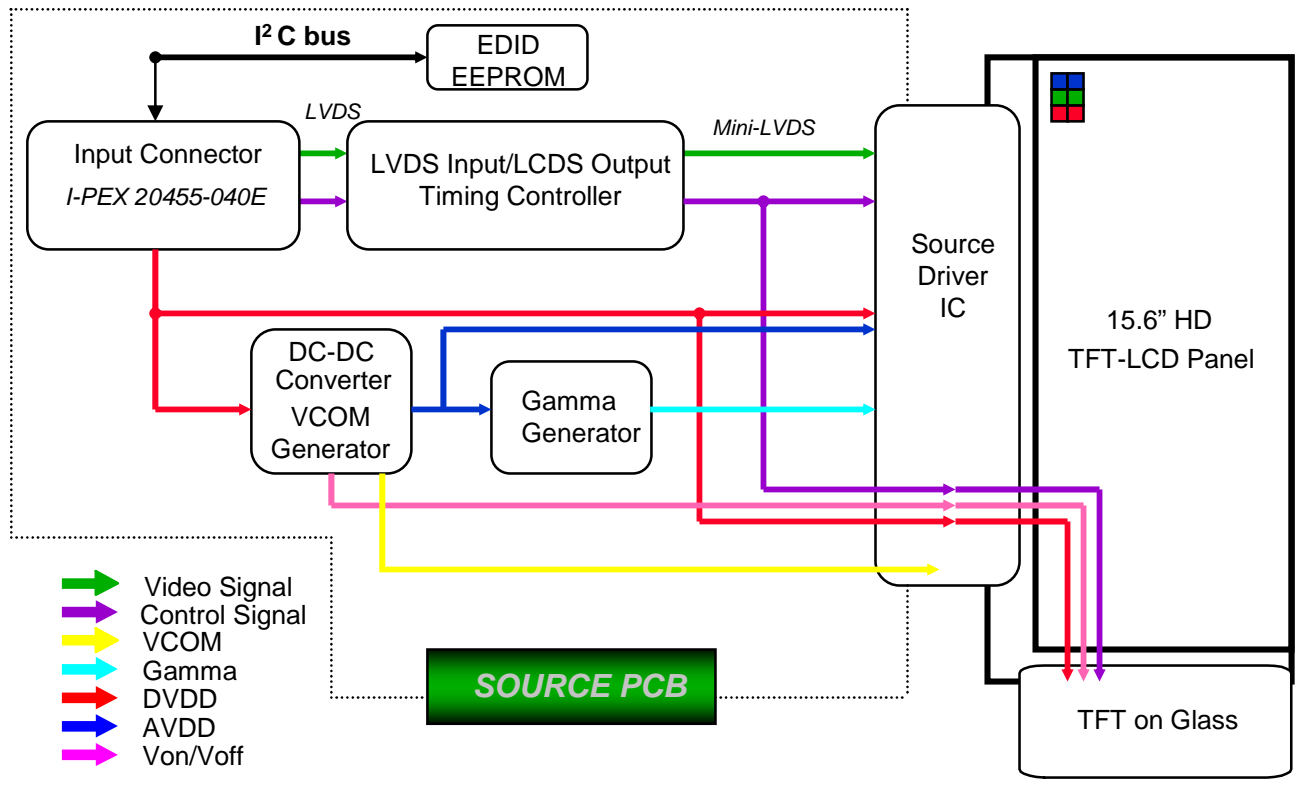

#### 4.2 LED connection and placement

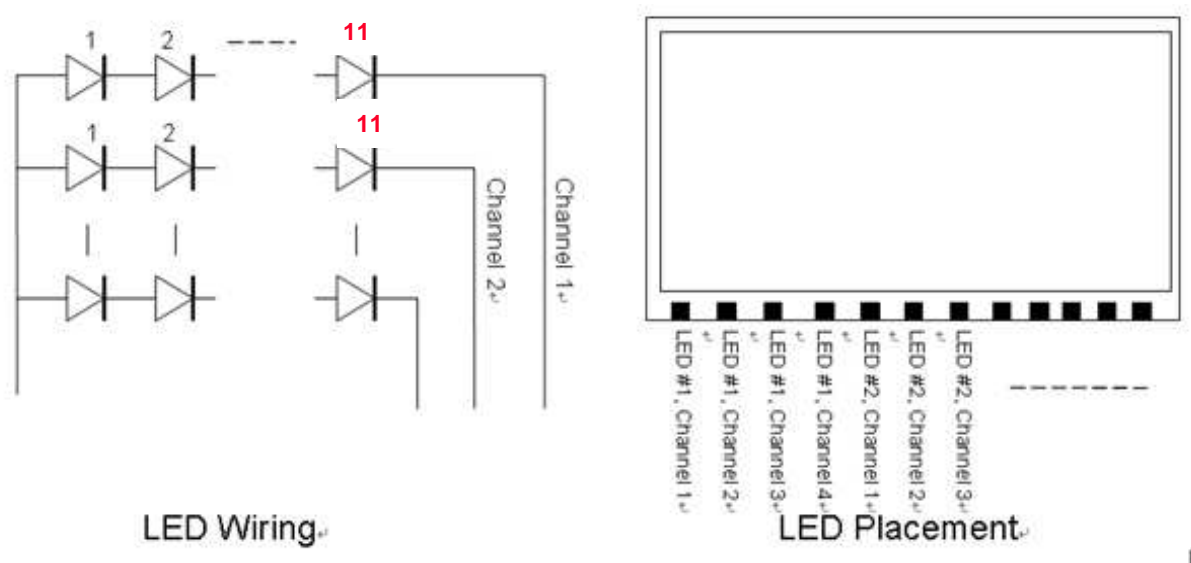

## 5. INPUT TERMINAL PIN ASSIGNMENT

### 5.1. Input Signal & Power (LVDS, Connector : I-PEX 20455-040E-02S or Compatible )

Pin	Symbol	Function
1	NC	No Connection (Reserved for supplier)
2	VCC	Power Supply, 3.3V (typical)
3	VCC	Power Supply, 3.3V (typical)
4	VCC_EDID	DDC 3.3V power
5	WPN	EDID writing protection
6	CLK_EDID	DDC Clock
7	DATA_EDID	DDC Data
8	RXin0-	- LVDS differential data (R0-R5, G0)
9	RXin0+	+ LVDS differential data (R0-R5, G0)
10	GND	Ground
11	RXin1-	- LVDS differential data (G1-G5, B0-B1)
12	RXn1+	+ LVDS differential data (G1-G5, B0-B1)
13	GND	Ground
14	RXin2-	- LVDS differential data (B2-B5,HS,VS, DE)
15	RXn2+	+ LVDS differential data (B2-B5,HS,VS, DE)
16	GND	Ground
17	ClKIN-	- LVDS differential clock input
18	ClKIN+	+ LVDS differential clock input
19	GND	Ground
20~21	NC	No Connection
22	GND	Ground
23~24	NC	No Connection
25	GND	Ground
26~27	NC	No Connection
28	GND	Ground
29~30	NC	No Connection
31~33	GND	LED Ground
34	NC	No Connection
35	PWM	PWM for luminance control
36	LED_EN	BL On/Off (On: 2.0~3.3V, Off: 0~0.5V)
37	NC	No Connection
38~40	VBL(7~20)	*LED Power Supply 7V-20V

**Samsung Secret**

### 5.2 LVDS Interface : Transmitter DS90CF363 or Compatible

Pin No.	Name	RGB Signal	Pin No.	Name	RGB Signal
51	TxIN0	R0	14	TxIN14	G5
52	TxIN1	R1	15	TxIN15	B0
54	TxIN2	R2	19	TxIN18	B1
55	TxIN3	R3	20	TxIN19	B2
56	TxIN4	R4	22	TxIN20	B3
3	TxIN6	R5	23	TxIN21	B4
4	TxIN7	G0	24	TxIN22	B5
6	TxIN8	G1	27	TxIN24	Hsync
7	TxIN9	G2	28	TxIN25	Vsync
11	TxIN12	G3	30	TxIN26	DE
12	TxIN13	G4	31	TxCLKIN	Clock

### LVDS INTERFACE

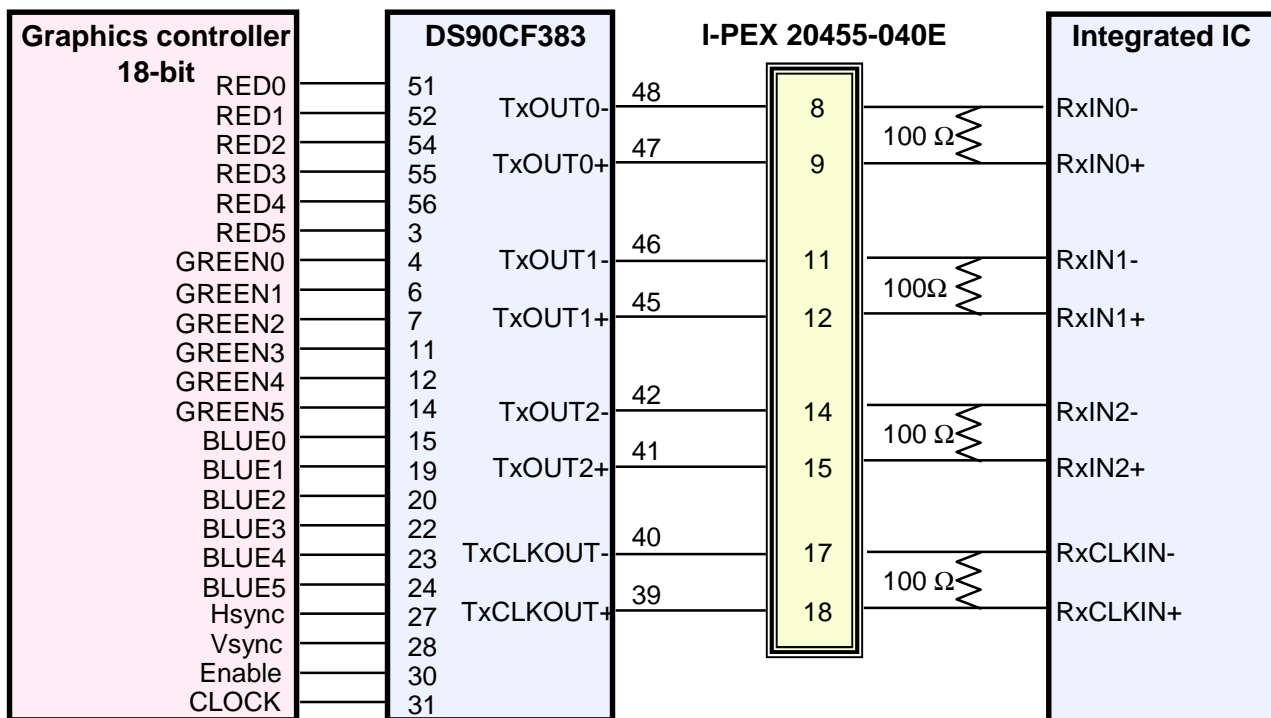

Note : The LCD Module uses a 100ohm resistor between positive and negative lines of each receiver input.

Samsung Secret

### 5.3 Timing Diagrams of LVDS For Transmission

#### LVDS Receiver : Integrated T-CON

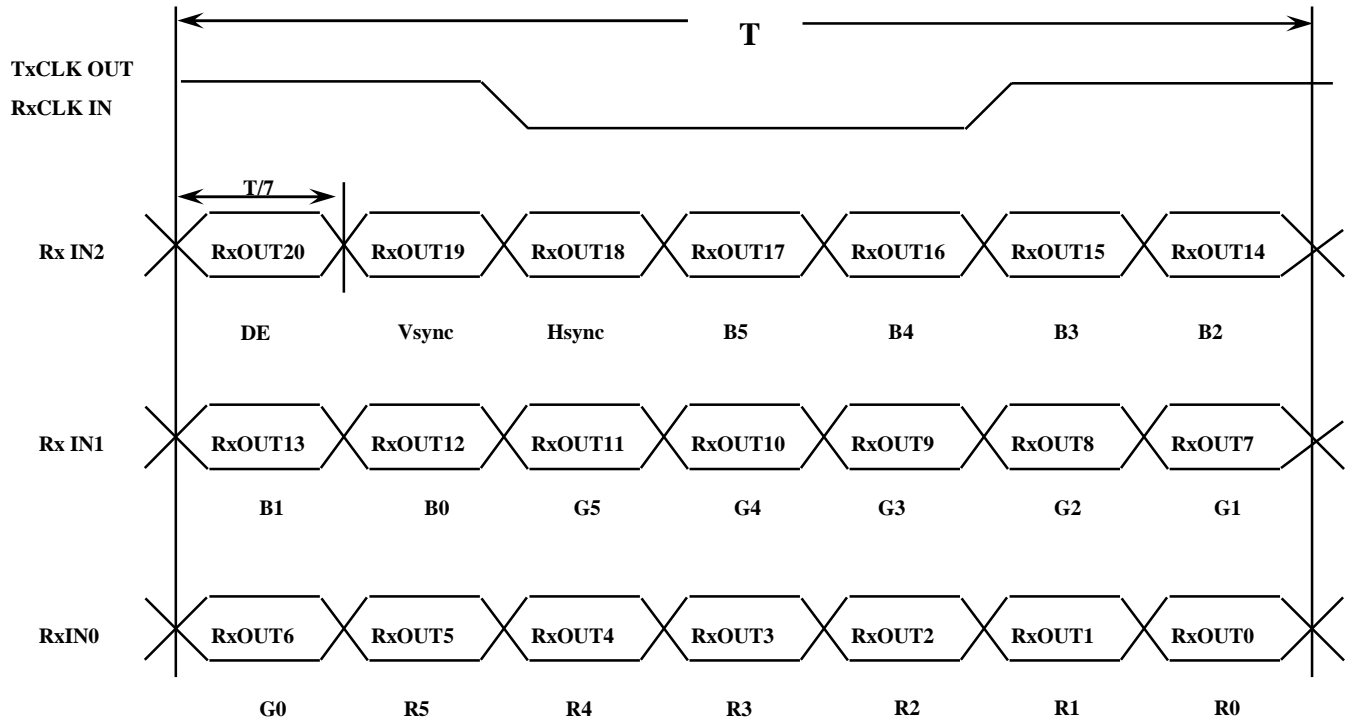

### 5.4 Input Signals, Basic Display Colors and Gray Scale of Each Color

Color	Display	Data Signal																Gray Scale Level	
		Red					Green					Blue							
		R0	R1	R2	R3	R4	R5	G0	G1	G2	G3	G4	G5	B0	B1	B2	B3		45
Basic Colors	Black	0	0	0	0	0	0	0	0	0	0	0	0	0	0	0	0	0	-
	Blue	0	0	0	0	0	0	0	0	0	0	0	0	1	1	1	1	1	-
	Green	0	0	0	0	0	0	1	1	1	1	1	1	0	0	0	0	0	-
	Cyan	0	0	0	0	0	0	1	1	1	1	1	1	1	1	1	1	1	-
	Red	1	1	1	1	1	1	0	0	0	0	0	0	0	0	0	0	0	-
	Magenta	1	1	1	1	1	1	0	0	0	0	0	0	1	1	1	1	1	-
	Yellow	1	1	1	1	1	1	1	1	1	1	1	1	0	0	0	0	0	-
	White	1	1	1	1	1	1	1	1	1	1	1	1	1	1	1	1	1	-
Gray Scale Of Red	Black	0	0	0	0	0	0	0	0	0	0	0	0	0	0	0	0	0	R0
	Dark	1	0	0	0	0	0	0	0	0	0	0	0	0	0	0	0	0	R1
	↑	0	1	0	0	0	0	0	0	0	0	0	0	0	0	0	0	0	R3~R60
	:	:	:	:	:	:	:	:	:	:	:	:	:	:	:	:	:	:	
	:	:	:	:	:	:	:	:	:	:	:	:	:	:	:	:	:	:	
	↓	1	0	1	1	1	1	0	0	0	0	0	0	0	0	0	0	0	R61
	Light	0	1	1	1	1	1	0	0	0	0	0	0	0	0	0	0	0	R62
	Red	1	1	1	1	1	1	0	0	0	0	0	0	0	0	0	0	0	R63
Gray Scale Of Green	Black	0	0	0	0	0	0	0	0	0	0	0	0	0	0	0	0	0	G0
	Dark	0	0	0	0	0	0	1	0	0	0	0	0	0	0	0	0	0	G1
	↑	0	0	0	0	0	0	0	1	0	0	0	0	0	0	0	0	0	G3~G60
	:	:	:	:	:	:	:	:	:	:	:	:	:	:	:	:	:	:	
	:	:	:	:	:	:	:	:	:	:	:	:	:	:	:	:	:	:	
	↓	0	0	0	0	0	0	1	0	1	1	1	1	0	0	0	0	0	G61
	Light	0	0	0	0	0	0	0	1	1	1	1	1	0	0	0	0	0	G62
	Green	0	0	0	0	0	0	1	1	1	1	1	1	0	0	0	0	0	G63
Gray Scale Of Blue	Black	0	0	0	0	0	0	0	0	0	0	0	0	0	0	0	0	0	B0
	Dark	0	0	0	0	0	0	0	0	0	0	0	0	1	0	0	0	0	B1
	↑	0	0	0	0	0	0	0	0	0	0	0	0	0	1	0	0	0	B3~B60
	:	:	:	:	:	:	:	:	:	:	:	:	:	:	:	:	:	:	
	:	:	:	:	:	:	:	:	:	:	:	:	:	:	:	:	:	:	
	↓	0	0	0	0	0	0	0	0	0	0	0	0	1	0	1	1	1	B61
	Light	0	0	0	0	0	0	0	0	0	0	0	0	0	1	1	1	1	B62
	Blue	0	0	0	0	0	0	0	0	0	0	0	0	1	1	1	1	1	B63

Note 1) MSB = R5,G5,B5, LSB=R0,G0,B0  
 Note 2) Input signal: 0 =Low level voltage, 1=High level voltage

**Samsung Secret**

### 5.5 Pixel Format in the display

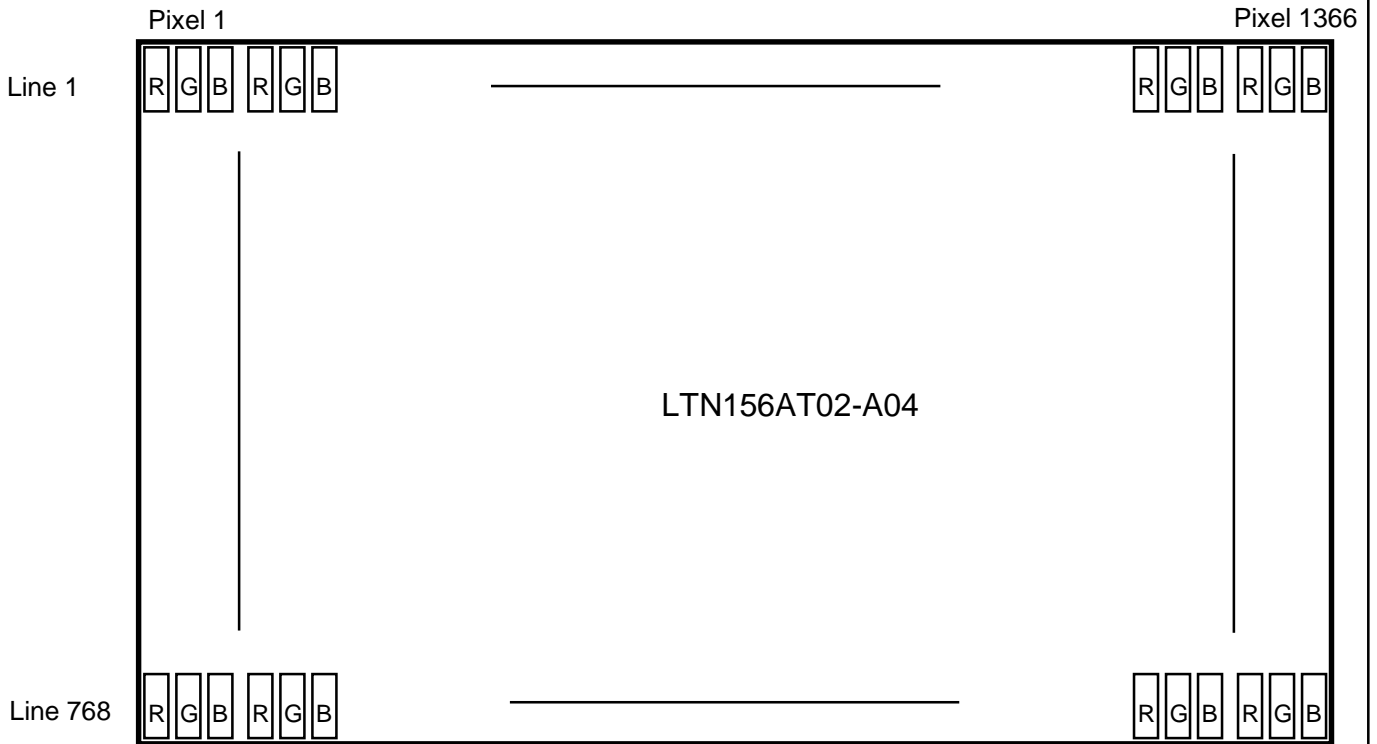

## 6. INTERFACE TIMING

### 6.1 Timing Parameters

Signal	Item	Symbol	Min.	Typ.	Max.	Unit	Note
Main Clock	Frequency	1/TC	-	72.33	-	MHz	-
Frame Frequency	Cycle	TV	776	790	1000	Lines	-
Vertical Active Display Term	Display Period	TVD	-	768	-	Lines	-
One Line Scanning Time	Cycle	TH	1386	1526	2049	Clocks	-
Horizontal Active Display Term	Display Period	THD	-	1366	-	Clocks	-

### 6.2 Timing diagrams of interface signal (DE only mode)

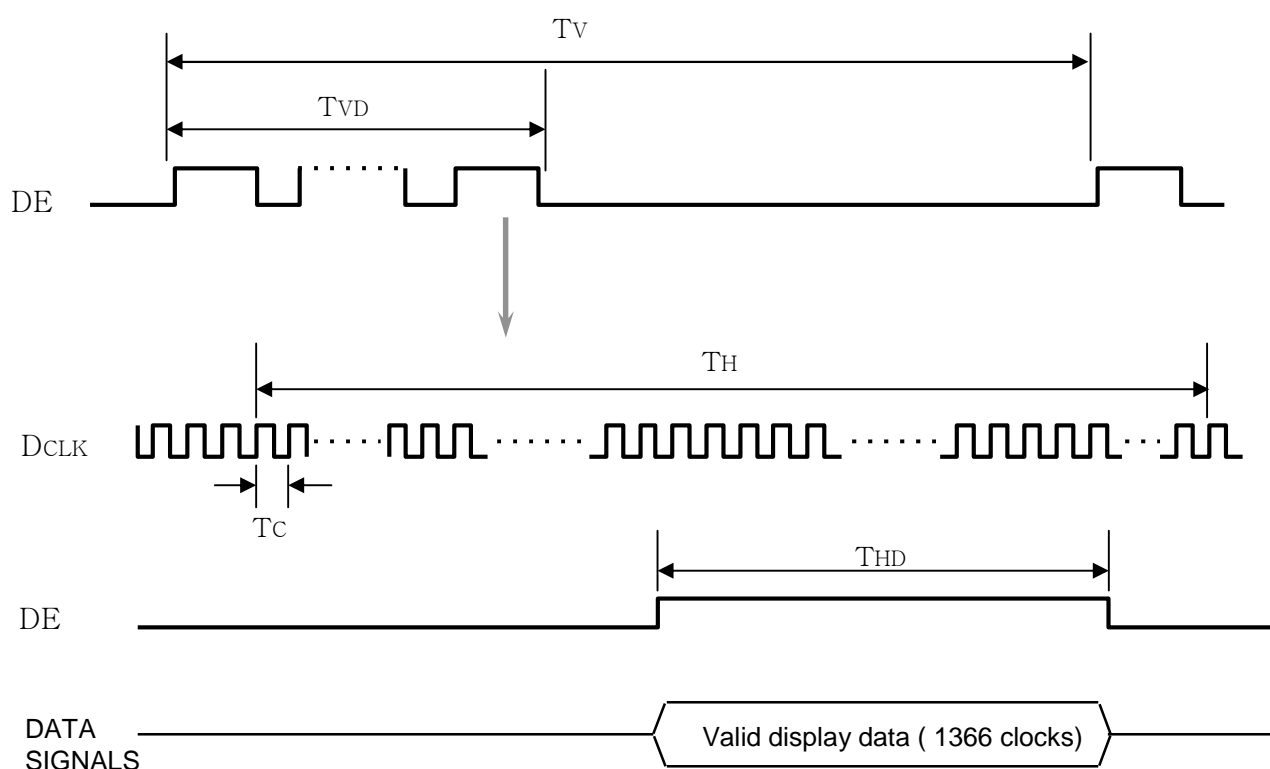

**Samsung Secret**

6.3 Power ON/OFF Sequence

: To prevent a latch-up or DC operation of the LCD module, the power on/off sequence should be as the diagram below.

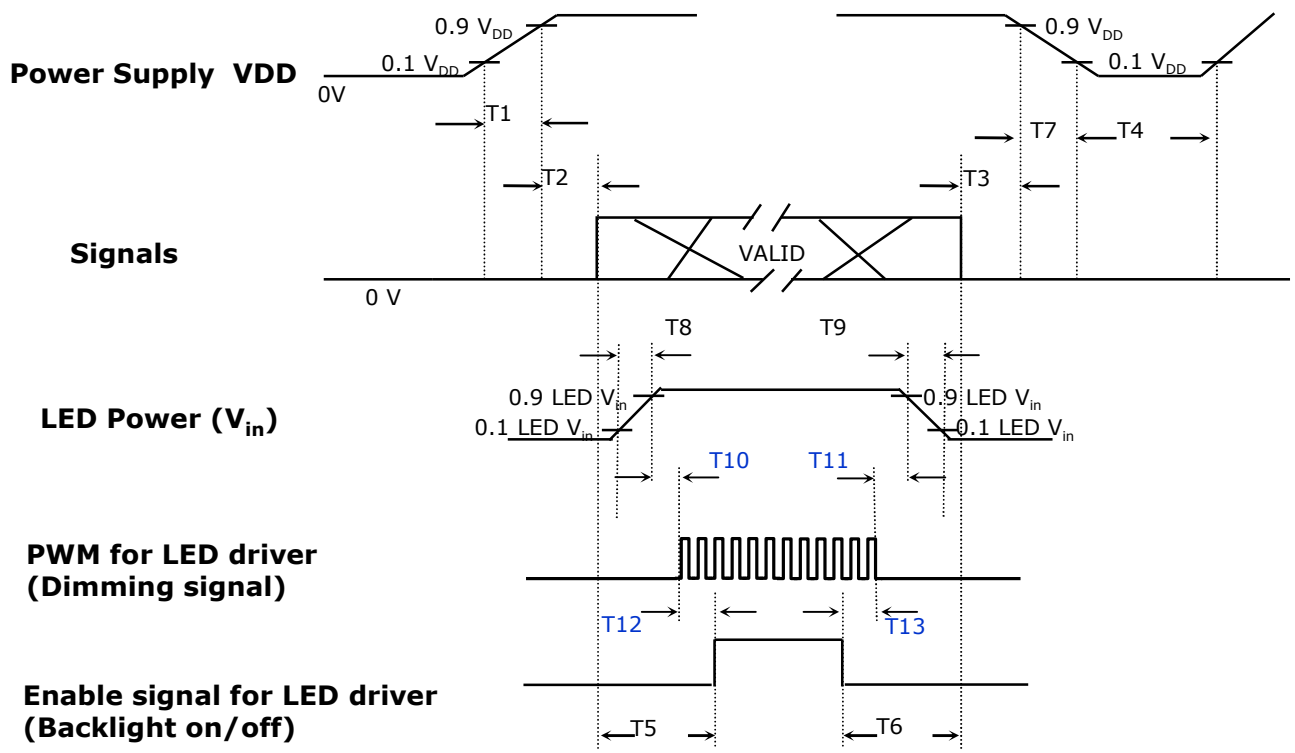

Power ON/OFF Sequence

Timing (ms)	Remarks
$0.5 < T1 \leq 10$	V <sub>DD</sub> rising time from 10% to 90%
$0 < T2 \leq 50$	Delay from V <sub>DD</sub> to valid data at power ON
$0 < T3 \leq 50$	Delay from valid data OFF to V <sub>DD</sub> OFF at power Off
$500 \leq T4$	V <sub>DD</sub> OFF time for Windows restart
$200 \leq T5$	Delay from valid data to B/L enable at power ON
$200 \leq T6$	Delay from valid data off to B/L disable at power Off
$0 < T7 \leq 10$	V <sub>DD</sub> falling time from 90% to 10%
$0.5 < T8 \leq 10$	LED V <sub>in</sub> rising time from 10% to 90%
$0.5 < T9 \leq 10$	LED V <sub>in</sub> falling time from 90% to 10%
$0 \leq T10$	Delay from LED driver Vin rising time 90% to PWM ON
$0 \leq T11$	Delay from PWM Off to LED driver Vin falling time 10%, Must Keep rule
$0 \leq T12$	Delay from PWM ON to B/L Enable ON, Must Keep rule
$0 \leq T13$	Delay from B/L Enable Off to PWM Off

Power Sequence & Timing Parameters

## 7. MECHANICAL OUTLINE DIMENSION

Please refer to the next page.

**Samsung Secret**

<b>Doc.No.</b>	LTN156AT02-A04	<b>Rev.No</b>	04-A00-G-091006	<b>Page</b>	21 / 30
----------------	----------------	---------------	-----------------	-------------	---------

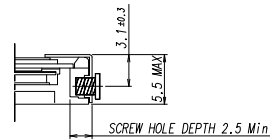
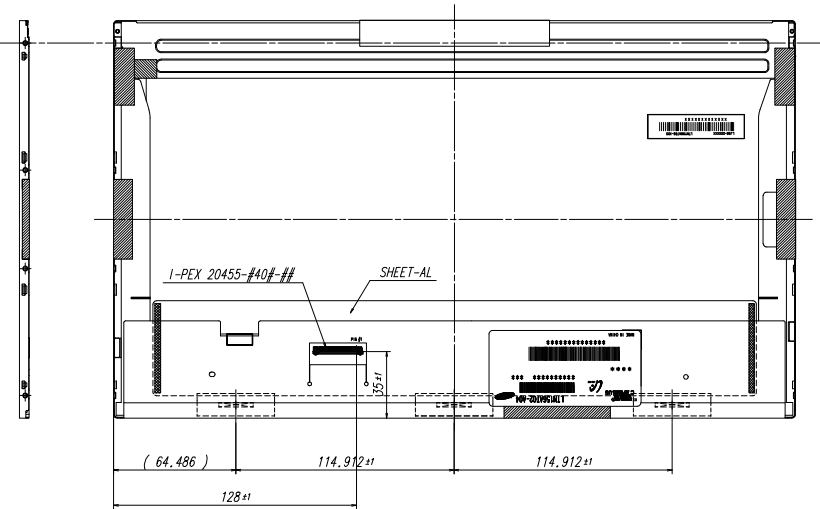
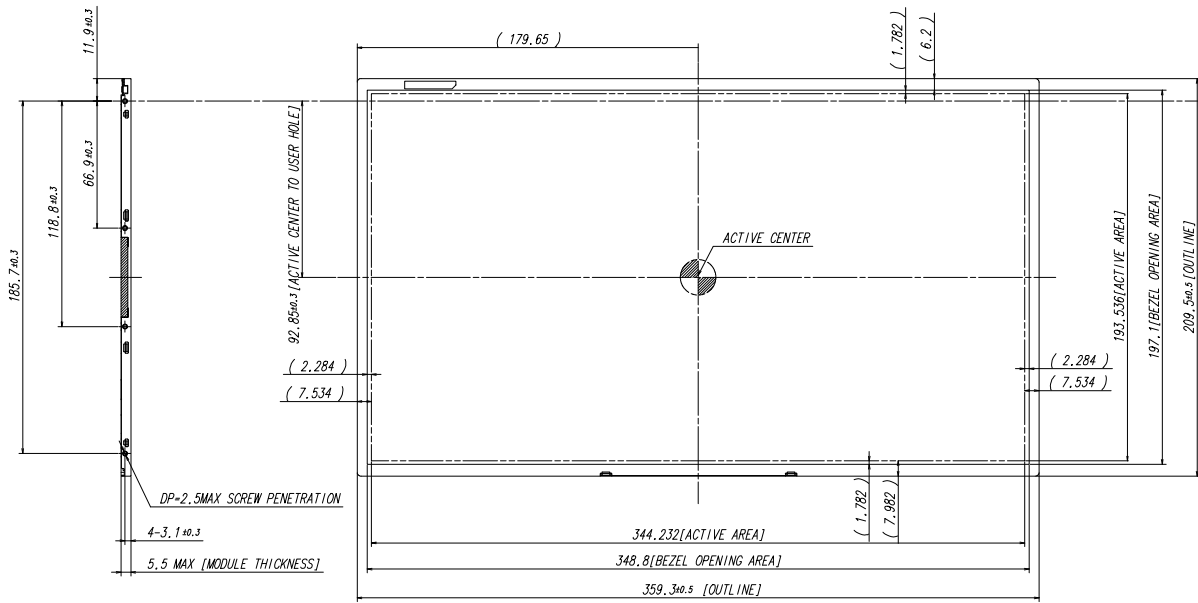

<USER HOLE SCREW HOLE DEPTH>

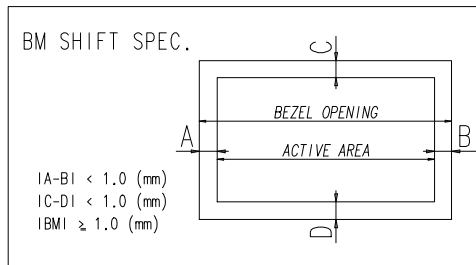

IA-BI < 1.0 (mm)  
 IC-DI < 1.0 (mm)  
 IBMI ≥ 1.0 (mm)

- \* NOTE
- SIGNAL INTERFACE CONNECTOR TO BE SPECIFIED AS BELOW.
    - MAKER : I-PEX OR COMPATIBLE
    - INPUT CONNECTOR : I-PEX 20455-#40#-## OR EQUIVALENT
  - LED CONNECTOR FOR BACKLIGHT TO BE SPECIFIED AS BELOW.
    - MAKER : UJU Electronics
    - PART NO : 51441-1041
  - CALIFERS MEASURING FORCE : 750 ± 250 gf/cm
  - MAXIMUM SCREW TORQUE : MAX 2.5 Kgf-cm(5TIMES)
  - WEIGHT : 465 g MAX
  - IN ORDER TO AVOID IC DAMAGE, IT IS NOT ALLOW THAT OVERLAPPING OF CABLES OR ANTENNAS, CAMERA, WLAN, WWAN, OVER THESE COF LOCATIONS.

REV#	DATE	DESCRIPTION OF REVISION	REASON	CHK'D BY
1	11.08.11	DRW'N BY [DESIGNER] BY [CHK'D] BY [APP'D] BY [ ]		
SCALE	1:1	H.K.KIM	MODEL NAME	LTN156AT02-AD4
FORM NUMBER	200.05.01		PART/SHEET NAME	OUTLINE DIMENSION SHEET 1/1
			SPEC. NO.	
			CODE NO.	
				VER. 000

**8. PACKING**

1. CARTON(Internal Package)

(1) Packing Form

Corrugated Cardboard box and Corrupad form as shock absorber

(2) Packing Method

CUSHION BOTTOM

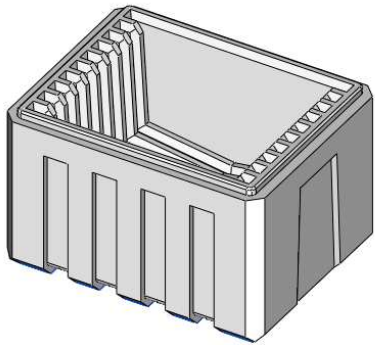

PANEL : 2EA/SLIT

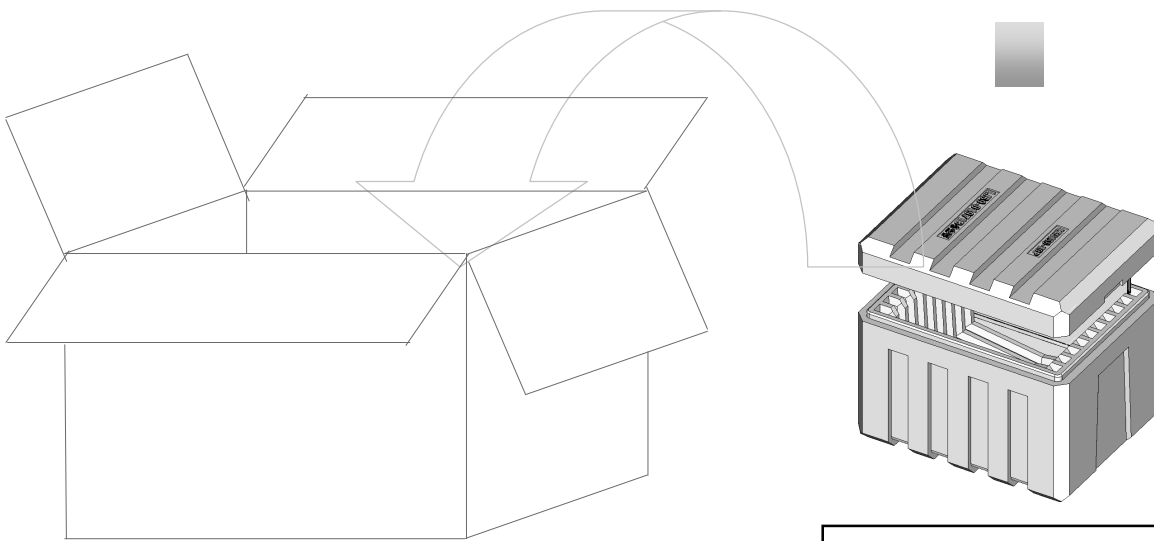
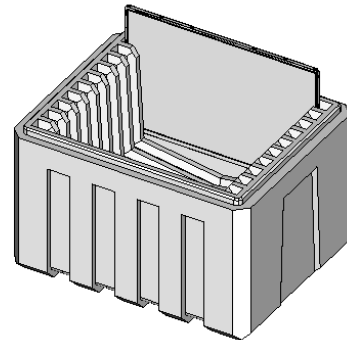

CUSHION TOP, BOTTOM

Note (1) Total : Approx. 12.4kg

(2) Acceptance number of piling : 20 sets

(3) Carton size : 359(W) X 463(D) X 333(H)

(4) Max accumulation quantity : 5 cartons

**Samsung Secret**

Doc.No.	LTN156AT02-A04	Rev.No	04-A00-G-091006	Page	23 / 30
---------	----------------	--------	-----------------	------	---------

(3)Packing Material

No	Part name	Quantity
1	Static electric protective sack	20
2	Packing case (Inner box) included shock absorber	1 set
3	Pictorial marking	2 pcs
4	Carton	1 set

**9. MARKINGS & OTHERS**

A nameplate bearing followed by is affixed to a shipped product at the specified location on each product.

(1)Parts number : LTN156AT02 –A04

(2)Revision code : 3 letters

(3)Lot number : X X X X XXX XX X A04

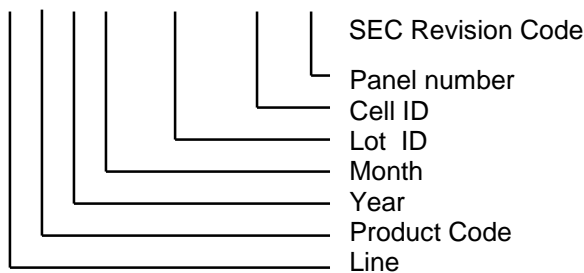

(4) Nameplate Indication

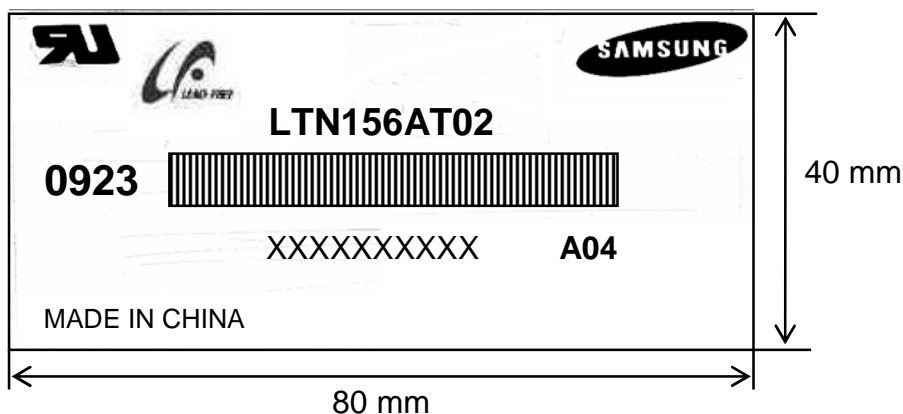

Parts name : LTN156AT02  
Lot number : XXXXXXXXXX  
Inspected work week : 0923(2009 year, 23th week)  
Product revision Code : A04

(5) Packing small box attach

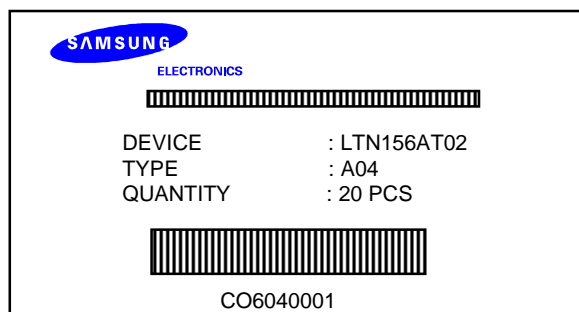

(6) Packing box Marking : Samsung TFT-LCD Brand Name



## 10. GENERAL PRECAUTIONS

### 1. Handling

- (a) When the module is assembled, It should be attached to the system firmly using every mounting holes. Be careful not to twist and bend the modules.
- (b) Refrain from strong mechanical shock and / or any force to the module. In addition to damage, this may cause improper operation or damage to the module.
- (c) Note that polarizers are very fragile and could be easily damaged. Do not press or scratch the surface harder than a HB pencil lead.
- (d) Wipe off water droplets or oil immediately. If you leave the droplets for a long time, Staining and discoloration may occur.
- (e) If the surface of the polarizer is dirty, clean it using some absorbent cotton or soft cloth.
- (f) The desirable cleaners are water, IPA (Isopropyl Alcohol) or Hexane. Do not use Ketone type materials(ex. Acetone), Ethyl alcohol, Toluene, Ethyl acid or Methyl chloride. It might permanent damage to the polarizer due to chemical reaction.
- (g) If the liquid crystal material leaks from the panel, it should be kept away from the eyes or mouth. In case of contact with hands, legs or clothes, it must be washed away thoroughly with soap.
- (h) Protect the module from static, it may cause damage to the C-MOS Gate Array IC.
- (i) Use fingerstalls with soft gloves in order to keep display clean during the incoming inspection and assembly process.
- (j) Do not disassemble the module.
- (k) Do not pull or fold the lamp wire.
- (l) Do not adjust the variable resistor which is located on the back side.
- (m) Protection film for polarizer on the module shall be slowly peeled off just before use so that the electrostatic charge can be minimized.
- (n) Pins of I/F connector shall not be touched directly with bare hands.

**Samsung Secret**

<b>Doc.No.</b>	LTN156AT02-A04	<b>Rev.No</b>	04-A00-G-091006	<b>Page</b>	26 / 30
----------------	----------------	---------------	-----------------	-------------	---------

## 2. STORAGE

- (a) Do not leave the module in high temperature, and high humidity for a long time.  
It is highly recommended to store the module with temperature from 0 to 35 °C and relative humidity of less than 70%.
- (b) Do not store the TFT-LCD module in direct sunlight.
- (c) The module shall be stored in a dark place. It is prohibited to apply sunlight or fluorescent light during the store.

## 3. OPERATION

- (a) Do not connect, disconnect the module in the “ Power On” condition.
- (b) Power supply should always be turned on/off by following item 6.3  
“ Power on/off sequence “.
- (c) Module has high frequency circuits. Sufficient suppression to the electromagnetic interference shall be done by system manufacturers. Grounding and shielding methods may be important to minimize the interference.
- (d) The standard limited warranty is only applicable when the module is used for general notebook applications. If used for purposes other than as specified, SEC is not to be held reliable for the defective operations. It is strongly recommended to contact SEC to find out fitness for a particular purpose.

## 4. OTHERS

- (a) Ultra-violet ray filter is necessary for outdoor operation.
- (b) Avoid condensation of water. It may result in improper operation or disconnection of electrode.
- (c) Do not exceed the absolute maximum rating value. ( the supply voltage variation, input voltage variation, variation in part contents and environmental temperature, so on)  
Otherwise the module may be damaged.
- (d) If the module displays the same pattern continuously for a long period of time, it can be the situation when the image “sticks” to the screen.
- (e) This module has its circuitry PCB's on the rear side and should be handled carefully in order not to be stressed.

**Samsung Secret**

<b>Doc.No.</b>	LTN156AT02-A04	<b>Rev.No</b>	04-A00-G-091006	<b>Page</b>	27 / 30
----------------	----------------	---------------	-----------------	-------------	---------

### 11. EDID

Address (HEX)	FUNCTION	Value	BIN	DEC	ASCII or Data	Notes
		HEX				
00	Header	00	00000000	0		EDID Header
01		FF	11111111	255		
02		FF	11111111	255		
03		FF	11111111	255		
04		FF	11111111	255		
05		FF	11111111	255		
06		FF	11111111	255		
07		00	00000000	0		
08	ID Manufacturer Name	4C	01001100	76	S E	3 character ID
09		A3	10100011	163	C	"SEC"
0A	ID Product Code	41	01000001	65	[A]	
0B		41	01000001	65	[A]	
0C	32-bit serial no.	00	00000000	0		
0D		00	00000000	0		
0E		00	00000000	0		
0F		00	00000000	0		
10	Week of manufacture	00	00000000	0		
11	Year of manufacture	13	00010011	19	2009	2009
12	EDID Structure Ver.	01	00000001	1	1	EDID Ver. 1.0
13	EDID revision #	03	00000011	3	0	EDID Rev. 0
14	Video input definition	80	10000000	128		
15	Max H image size	22	00100010	34	34	34 cm(approx)
16	Max V image size	13	00010011	19	19	19 cm(approx)
17	Display Gamma	78	01111000	120	2.2	Gamma 2.2
18	Feature support	0A	00001010	10		
19	Red/green low bits	8D	10001101	141		10000111
1A	Blue/white low bits	A5	10100101	165		11111110
1B	Red x/ high bits	9D	10011101	157	0.615	Red x 0.615= 100101001
1C	Red y	5B	01011011	91	0.355	Red y 0.355= 01011011
1D	Green x	55	01010101	85	0.335	Green x 0.300= 01010101
1E	Green y	9C	10011100	156	0.610	Green y 0.570= 10011100
1F	Blue x	26	00100110	38	0.150	Blue x 0.145= 00100110
20	Blue y	19	00011001	25	0.100	Blue y 0.080= 00011001
21	White x	50	01010000	80	0.313	White x 0.313= 01010000
22	White y	54	01010100	84	0.329	White y 0.329= 01010100
23	Established timing 1	00	00000000	0		
24	Established timing 2	00	00000000	0		

Samsung Secret

25	Established timing 3	00	00000000	0			
26	Standard timing #1	01	00000001	1		not used	
27		01	00000001	1			
28	Standard timing #2	01	00000001	1		not used	
29		01	00000001	1			
2A	Standard timing #3	01	00000001	1		not used	
2B		01	00000001	1			
2C	Standard timing #4	01	00000001	1		not used	
2D		01	00000001	1			
2E	Standard timing #5	01	00000001	1		not used	
2F		01	00000001	1			
30	Standard timing #6	01	00000001	1		not used	
31		01	00000001	1			
32	Standard timing #7	01	00000001	1		not used	
33		01	00000001	1			
34	Standard timing #8	01	00000001	1		not used	
35		01	00000001	1			
36	Detailed timing/monitor descriptor #1	41	01000001	65	72.33	Main clock= 72.33 MHz	
37		1C	00011100	28			
38		56	01010110	86	1366	Hor active=1366 pixels	
39		A0	10100000	160	160	Hor blanking=160 pixels	
3A		50	01010000	80		4bit : 4bit	
3B		00	00000000	0	768	Vertical active=768 lines	
3C		16	00010110	22	22	Vertical blanking=22 lines	
3D		30	00110000	48		4bit : 4bit	
3E		30	00110000	48	48		
3F		20	00100000	32	32	H sync. Width=32 pixels	
40			25	00100101	37	2 5	V sync. Offset=2 lines V sync. Width=5 lines
41			00	00000000	0		2bit : 2bit :2bit :2bit
42			58	01011000	88	344	H image size= 344 mm(app
43			C1	11000001	193	193	V image size = 193 mm(app
44			10	00010000	16		
45		00	00000000	0		No Horizontal Border	
46		00	00000000	0		No Vertical Border	
47		19	00011001	25			
48	Detailed timing/monitor descriptor #2	00	00000000	0		Manufacturer Specified (Tim	
49		00	00000000	0			
4A		00	00000000	0			
4B		0F	00001111	15			
4C		00	00000000	0			
4D		00	00000000	0		Value=HSPWmin / 2	
4E		00	00000000	0		Value=HSPWmax / 2	
4F		00	00000000	0		Value=Thbpmin / 2	
50		00	00000000	0		Value=Thbpmax / 2	
51		00	00000000	0		Value=VSPWmin / 2	
52		00	00000000	0		Value=VSPWmax / 2	
53		00	00000000	0		Value=Tvbpmmin / 2	
54		00	00000000	0		Value=Tvbpmmax / 2	
55		1E	00011110	30		Thpmin=value*2 + HA pixel	
56		B4	10110100	180		Thpmax=value*2 + HA pixel	
57	02	00000010	2		Tvpmin=value*2 + VA lines		
58	74	01110100	116		Tvpmax=value*2 + VA lines		
59	00	00000000	0		Module revision		

Samsung Secret

5A	Detailed timing/monitor descriptor #3	00	00000000	0		ASCII Data String Tag
5B		00	00000000	0		
5C		00	00000000	0		
5D		FE	11111110	254		
5E		00	00000000	0		
5F		53	01010011	83	[S]	
60		41	01000001	65	[A]	
61		4D	01001101	77	[M]	
62		53	01010011	83	[S]	
63		55	01010101	85	[U]	
64		4E	01001110	78	[N]	
65		47	01000111	71	[G]	
66		0A	00001010	10	[*]	
67		20	00100000	32	[ ]	
68		20	00100000	32	[ ]	
69	20	00100000	32	[ ]		
6A	20	00100000	32	[ ]		
6B	20	00100000	32	[ ]		
6C	Detailed timing/monitor descriptor #4	00	00000000	0		Monitor Name Tag (ASCII)
6D		00	00000000	0		
6E		00	00000000	0		
6F		FE	11111110	254		
70		00	00000000	0		
71		31	00110001	49	[1]	
72		35	00110101	53	[5]	
73		36	00110110	54	[6]	
74		41	01000001	65	[A]	
75		54	01010100	84	[T]	
76		30	00110000	48	[0]	
77		32	00110010	50	[2]	
78		2D	00101101	45	[-]	
79		41	01000001	65	[A]	
7A		30	00110000	48	[0]	
7B	34	00110100	52	[4]		
7C	0A	00001010	10	[*]		
7D	20	00100000	32	[ ]		
7E	Extension Flag	00	00000000	0		
7F	Checksum	EF	11101111	239		