

mass integrated

global part distribution • product lifecycle partner
excess inventory management • value-ad service provider



Data sheet provided by Mass Integrated

massintegrated.com • displayalliance.com

Please call +1.978.465.6190
Email: sales@massintegrated.com



ISO 9001: 2008

Mass Integrated complies with all DMCA takedown notices. Please send a formal DMCA Takedown Notice to Mass Integrated Systems, Inc. • 18 Henry Graf Jr. Road, Unit 1 • Newburyport, MA 01950.

SAMSUNG

ELECTRONICS

Approval



TO :
DATE : December. 5. 2008

SAMSUNG TFT-LCD

MODEL NO : LTN156AT02-D

NOTE : Extension code [-D]
→ LTN156AT02-**D**
Surface type [Glare, True life]

The information described in this SPEC is preliminary and can be changed without prior notice.

APPROVED BY :

K. H. Shin

PREPARED BY : LCD Application Engineering Part (Mobile)

SAMSUNG ELECTRONICS CO., LTD.



Samsung Secret

Doc.No.	LTN156AT02-D	Rev.No	04-A01-S-081205	Page	1 / 30
---------	--------------	--------	-----------------	------	--------

CONTENTS

Revision History	----- (3)
General Description	----- (4)
1. Absolute Maximum Ratings	----- (5)
1.1 Absolute Ratings of environment	
1.2 Electrical Absolute Ratings	
2. Optical Characteristics	----- (7)
3. Electrical Characteristics	----- (10)
3.1 TFT LCD Module	
3.2 Backlight Unit	
3.3 LED Driver	
4. Block Diagram	----- (13)
4.1 TFT LCD Module	
5. Input Terminal Pin Assignment	----- (14)
5.1 Input Signal & Power	
5.2 LVDS Interface	
5.3 Timing Diagrams of LVDS For Transmitting	
5.4 Input Signals, Basic Display Colors and Gray Scale of Each Color.	
5.5 Pixel format	
6. Interface Timing	----- (19)
6.1 Timing Parameters	
6.2 Timing Diagrams of interface Signal	
6.3 Power ON/OFF Sequence	
7. Outline Dimension	----- (21)
8. Packing	----- (22)
9. Markings & Others	----- (23)
10. General Precautions	----- (25)
11. EDID	----- (28)

Samsung Secret

REVISION HISTORY

Approval

Date	Revision No.	Page	Summary
Aug. 4. 2008	P00	All	LTN156AT02-D model spec was issued first.
Aug. 6. 2008	P01	All	LTN156AT02-D model spec was updated based on DELL spec
Nov. 7. 2008	P02	24	Label configuration was updated
Nov. 20. 2008	A00	All	Approval spec was issued
Dec. 5. 2008	A01	23	Packing was updated

Samsung Secret

Doc.No.	LTN156AT02-D	Rev.No	04-A01-S-081205	Page	3 / 30
----------------	--------------	---------------	-----------------	-------------	--------

GENERAL DESCRIPTION

DESCRIPTION

LTN156AT02-D is a color active matrix TFT (Thin Film Transistor) liquid crystal display (LCD) that uses amorphous silicon TFT as switching devices. This model is composed of a TFT LCD panel, a driver circuit and a backlight system. The resolution of a 15.6" contains 1366 x 768 pixels and can display up to 262,144 colors. 6 O'clock direction is the Optimum viewing angle.

FEATURES

- Thin and light weight
- High contrast ratio, high aperture structure
- 1366 x 768 pixels resolution (16:9)
- Fast Response Time
- Low power consumption
- LED BLU Structure
- DE (Data enable) only mode
- 3.3V LVDS Interface
- On board EDID chip
- Pb-free product

APPLICATIONS

- Notebook PC
- If the usage of this product is not for PC application, but for others, please contact SEC

GENERAL INFORMATION

Item	Specification	Unit	Note
Display area	344.232 (H) x 193.536 (V) (15.6"diagonal)	mm	
Driver element	a-Si TFT active matrix		
Display colors	262,144		
Number of pixel	1366 x 768	pixel	16 : 9
Pixel arrangement	RGB vertical stripe		
Pixel pitch	0.252 (H) x 0.252 (V) (TYP.)	mm	
Display Mode	Normally white		
Surface treatment	Haze 0, Hardness 3H		Glare

Samsung Secret

Doc.No.	LTN156AT02-D	Rev.No	04-A01-S-081205	Page	4 / 30
----------------	--------------	---------------	-----------------	-------------	--------

Mechanical Information

Item		Min.	Typ.	Max.	Unit	Note
Module size	Horizontal (H)	358.8	359.3	359.8	mm	
	Vertical (V)	209.0	209.5	210	mm	
	Depth (D)	-	-	5.5	mm	(1)
Weight		-	-	450	g	

Note (1) Measurement condition of outline dimension

- . Equipment : Vernier Calipers
- . Push Force : 500g · f (minimum)

1. ABSOLUTE MAXIMUM RATINGS

1.1 ENVIRONMENTAL ABSOLUTE RATINGS

Item	Symbol	Min.	Max.	Unit	Note
Storage temperate	TSTG	-20	60	°C	(1)
Operating temperate (Temperature of glass surface)	TOPR	0	50	°C	(1)
Shock (non-operating)	Snop	-	240	G	(2),(4)
Vibration (non-operating)	Vnop	-	2.41	G	(3),(4)

Note (1) Temperature and relative humidity range are shown in the figure below.

95 % RH Max. ($40\text{ }^{\circ}\text{C} \geq T_a$)

Maximum wet - bulb temperature at $39\text{ }^{\circ}\text{C}$ or less. ($T_a > 40\text{ }^{\circ}\text{C}$) No condensation

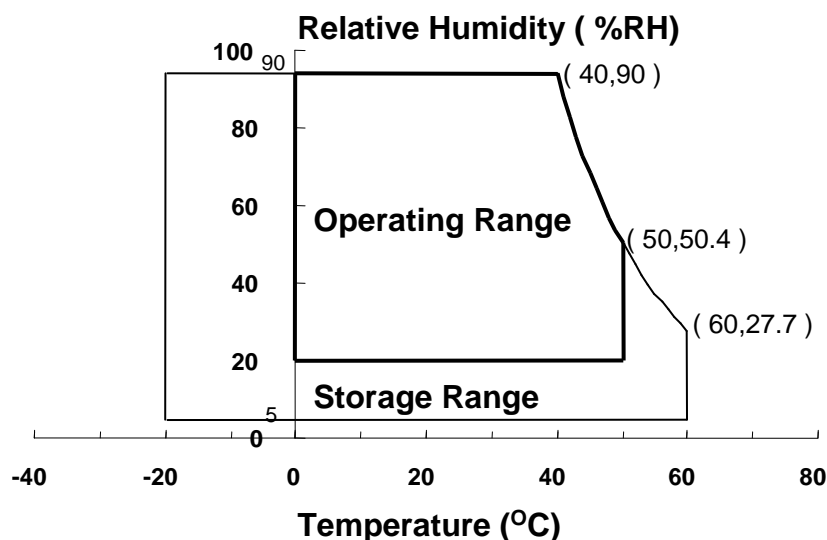

(2) 2ms, half sine wave, one time for $\pm X, \pm Y, \pm Z$.

(3) 5 - 500 Hz, random vibration, 30min for X, Y, Z.

(4) At testing Vibration and Shock, the fixture in holding the Module to be tested have to be hard and rigid enough so that the Module would not be twisted or bent by the fixture.

Samsung Secret

1.2 ELECTRICAL ABSOLUTE RATINGS

(1) TFT LCD MODULE

 $V_{DD} = 3.3V, V_{SS} = GND = 0V$

Item	Symbol	Min.	Max.	Unit	Note
Power Supply Voltage	V_{DD}	$V_{DD} - 0.3$	$V_{DD} + 0.3$	V	(1)
Logic Input Voltage	V_{DD}	$V_{DD} - 0.3$	$V_{DD} + 0.3$	V	(1)

Note (1) Within T_a (25 ± 2 °C)

Samsung Secret

2. OPTICAL CHARACTERISTICS

The following items are measured under stable conditions. The optical characteristics should be measured in a dark room or equivalent state with the methods shown in Note (5).
Measuring equipment : TOPCON SR-3

* Ta = 25 ± 2 °C, VDD=3.3V, fv= 60Hz, fdCLK = 72.33 MHz, IL = 20 mA

Item		Symbol	Condition	Min.	Typ.	Max	Unit	Note
Contrast Ratio (5 Points)		CR	Normal Viewing Angle $\phi = 0$ $\theta = 0$	500	600	-	-	(1), (2), (5)
Response Time at Ta (Rising + Falling)		T _{RT}		-	25	35	msec	(1), (3)
Average Luminance of White (5 Points)		Y _{L,AVE}		200	220	-	cd/m ²	IL=19mA (1), (4)
Color Chromaticity (CIE)	Red	R _X		0.590	0.620	0.650	-	
		R _Y		0.310	0.340	0.370		
	Green	G _X		0.300	0.330	0.360		
		G _Y		0.540	0.570	0.600		
	Blue	B _X		0.120	0.150	0.180		
		B _Y		0.030	0.060	0.090		
	White	W _X		0.283	0.313	0.343		
		W _Y	0.299	0.329	0.359			
Viewing Angle	Hor.	θ_L	CR ≥ 10	40	-	-	Degrees	(1), (5) SR-3
		θ_R		40	-	-		
	Ver.	ϕ_H		15	-	-		
		ϕ_L		30	-	-		
Color Gamut				-	60	-	%	
13 Points White Variation		δ_L		-	-	1.7	-	(6)

Samsung Secret

Note 1) Definition of Viewing Angle : Viewing angle range($10 \leq C/R$)

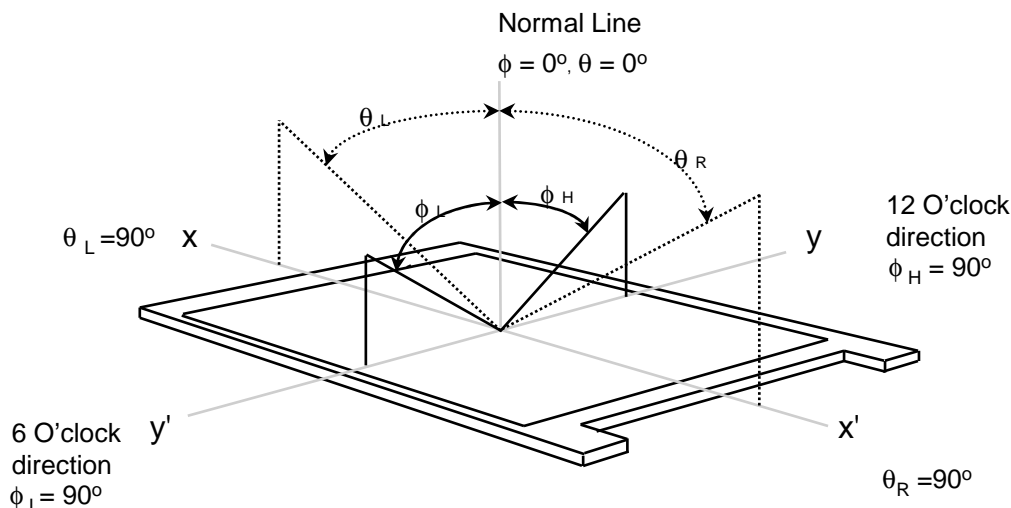

Note 2) Definition of Contrast Ratio (CR) : Ratio of gray max (Gmax) ,gray min (Gmin) at 5 points(4, 5, 7, 9, 10)

$$CR = \frac{CR(4) + CR(5) + CR(7) + CR(9) + CR(10)}{5}$$

Points : (4) , (5) , (7) , (9) , (10) at the figure of Note (6).

Note 3) Definition of Response time :

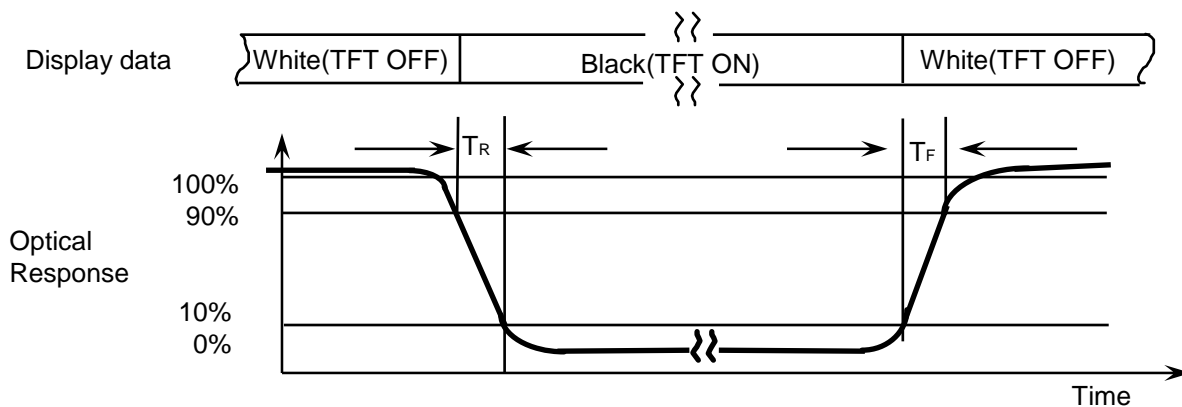

Note 4) Definition of Average Luminance of White : measure the luminance of white at 5 points.

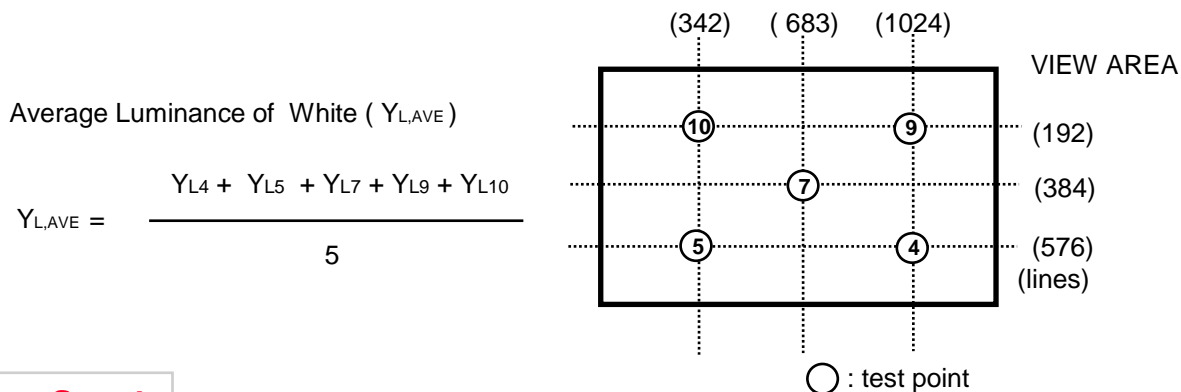

Samsung Secret

Note 5) After stabilizing and leaving the panel alone at a given temperature for 30 min , the measurement should be executed. Measurement should be executed in a stable, windless, and dark room. 30 min after lighting the backlight. This should be measured in the center of screen.
 LED current : 20 mA
 Environment condition : $T_a = 25 \pm 2 \text{ }^\circ\text{C}$

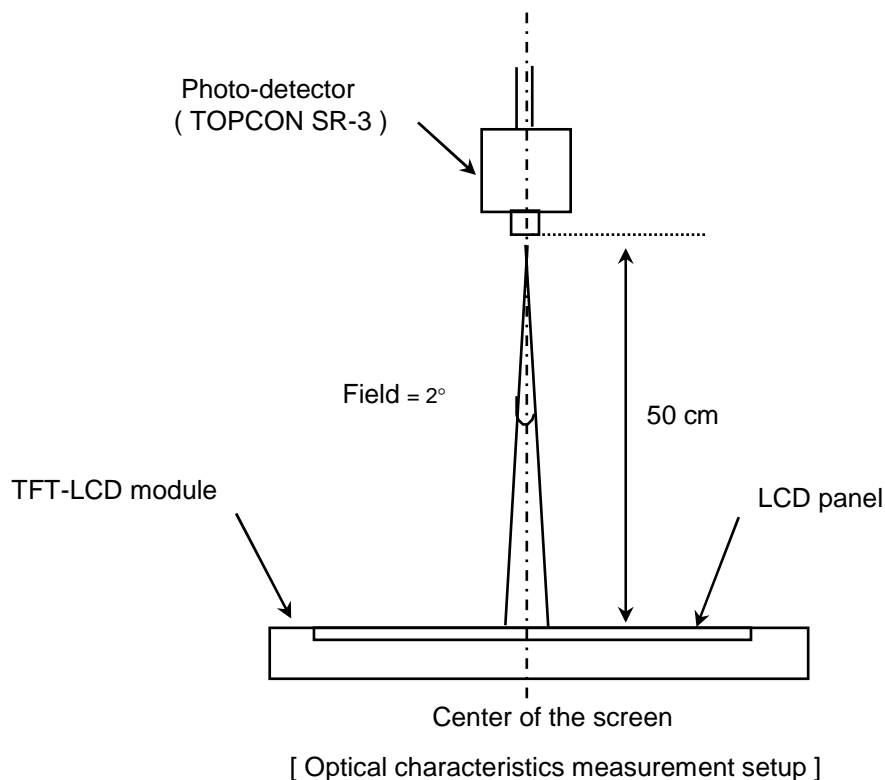

Note 6) Definition of 13 points white variation (δL), [① ~ ⑬]

$$\delta L = \frac{\text{Maximum luminance of 13 points}}{\text{Minimum luminance of 13 points}}$$

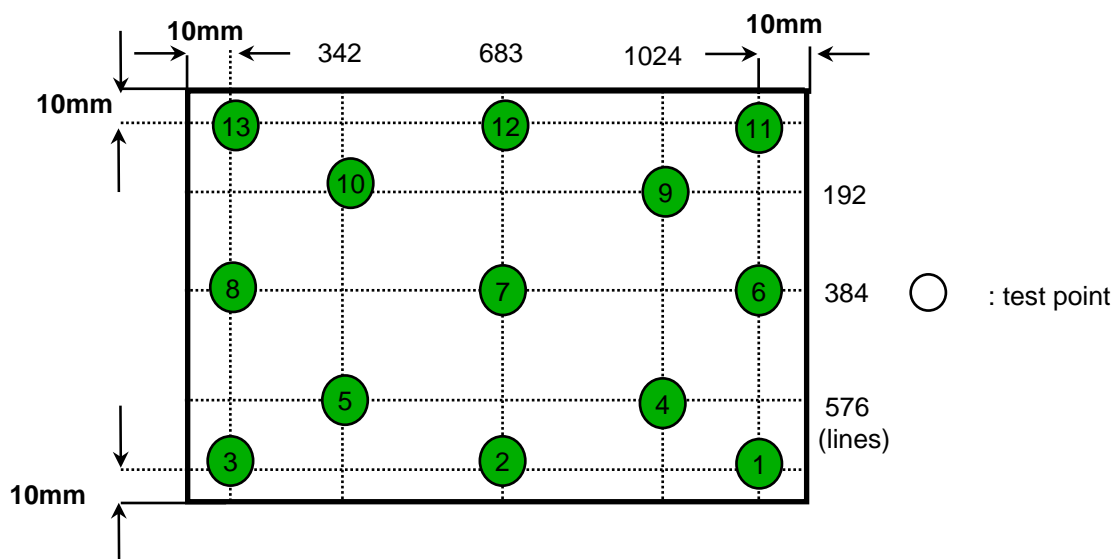

Samsung Secret

3. ELECTRICAL CHARACTERISTICS

Approval

3.1 TFT LCD MODULE

Ta= 25 ± 2°C

Item	Symbol	Min.	Typ.	Max.	Unit	Note	
Voltage of Power Supply	V _{DD}	3.0	3.3	3.6	V		
Differential Input Voltage for LVDS Receiver Threshold	High	V _{IH}	-	-	+100	mV	V _{CM} = +1.2V
	Low	V _{IL}	-100	-	-	mV	
Vsync Frequency	f _v	-	60	-	Hz		
Hsync Frequency	f _H	-	47.40	-	KHz		
Main Frequency	f _{DCLK}	-	72.33	-	MHz		
Rush Current	I _{RUSH}	-	-	1.5	A	(4)	
Current of Power Supply	White	I _{DD}	-	360	-	mA	(2),(3)*a
	Mosaic		-	420	-	mA	(2),(3)*b
	V. Stripe		-	530	600	mA	(2),(3)*c

Note (1) Display data pins and timing signal pins should be connected.(GND = 0V)

(2) f_v = 60Hz, f_{DCLK} = 72.33 MHz, V_{DD} = 3.3V , DC Current.

(3) Power dissipation pattern

*a) White Pattern

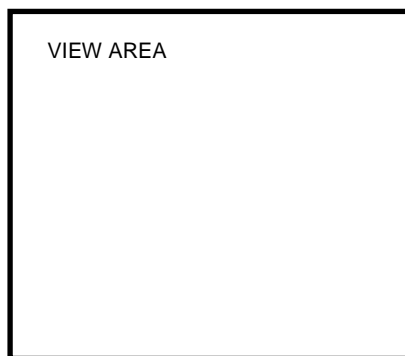

*b) Mosaic Pattern

Display Brightest Gray Level →

Display Darkest Gray Level →

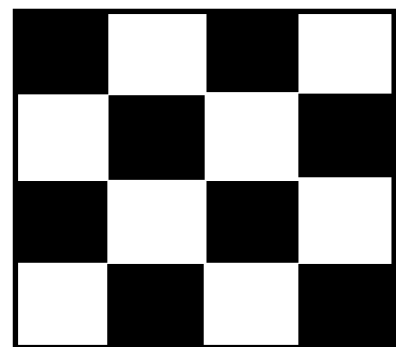

Samsung Secret

*c) 1dot Vertical stripe pattern

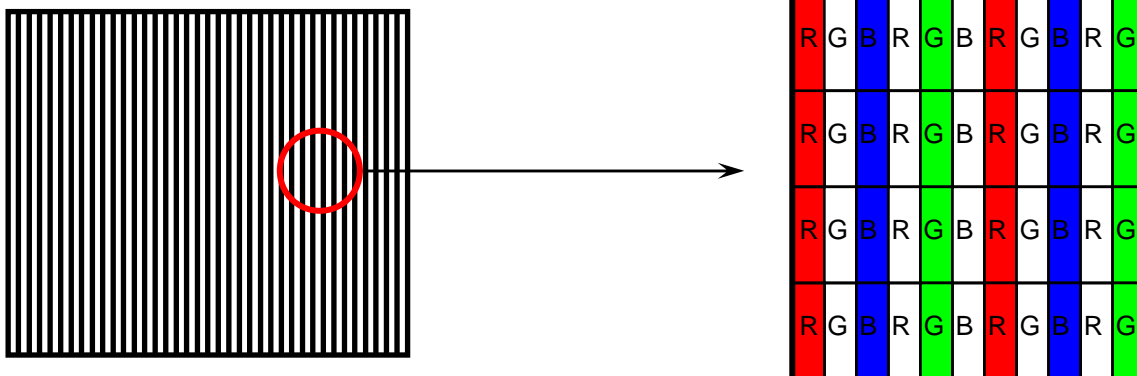

4) Rush current measurement condition

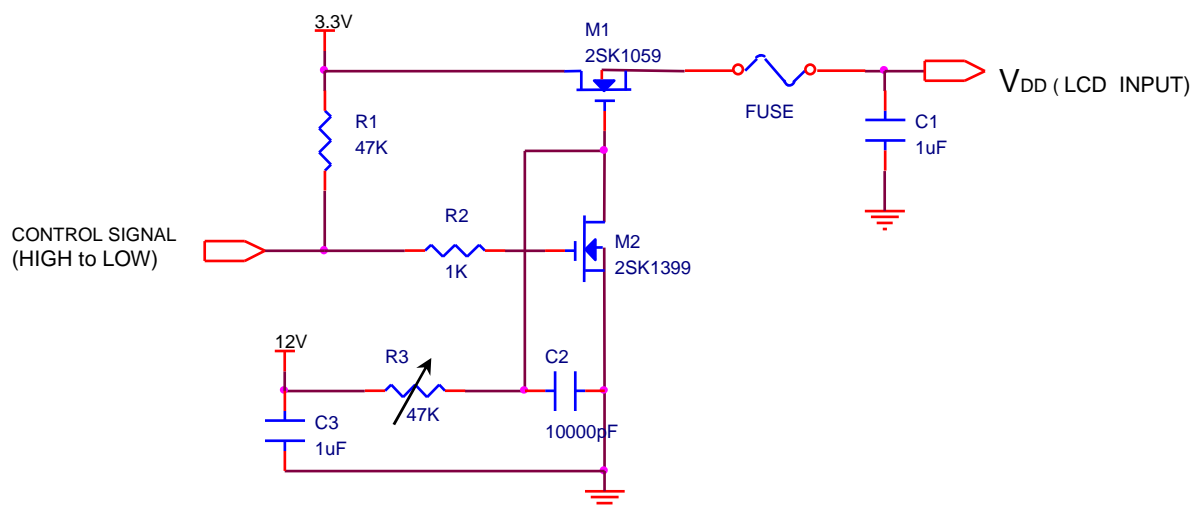

V_{DD} rising time is 470us

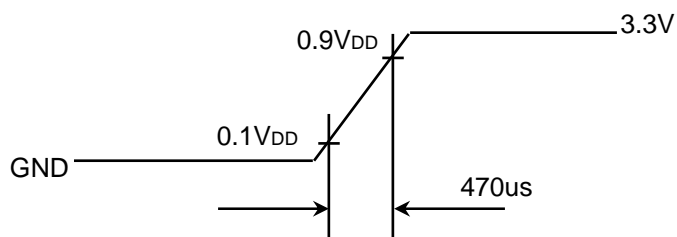

Samsung Secret

3.2 BACK-LIGHT UNIT

Ta= 25 ± 2 °C

Item	Symbol	Min.	Typ.	Max.	Unit	Note
LED Forward Current	IF	-	20	-	mA	
LED Forward Voltage	VF	3.0	-	3.4	V	
LED Array Voltage	VP	24	-	27.2	V	VF X 8 LEDs
Power Consumption	P	2.88	-	3.26	W	IF X VF X 48 LEDs (w/o Converter)

3.3 LED Driver

- LED Driver Manufacturer : ST Micro

Ta= 25 ± 2 °C

Item	Symbol	Min.	Typ.	Max.	Unit	Note
Input Voltage	V _{in}	4.7	-	28	V	
Input Current	I	-	2A RMS 5A Peak	-	mA	Max.MOSFET curent in PM6600
Input Power	P _{in}	-	-	-	W	
Operating Frequency	F _o	200KHz	660KHz	1MHz	MHz	600KHz Possible
Output PWM Frequency	F _{PWM}	-	-	-	kHz	No output PWM
Burst Ratio	D	1	-	100	%	PWM freq : 200Hz~20KHz
External PWM Dimming Control Frequency (BLIM)	F _{BLIM}	200Hz	-	20KHz	kHz	V _{in} =8~21V, BLIM=PWM 0V~3.3V
Output Power	P _{out}	-	-	2.3	W	BLIM=100%
Efficiency	η	88	-	94	%	(Generally, Efficiency can be defined depends on Duty cycle , V _{in} and Dimming Freq.)

Note - Test Equipment : Fluke 45

Samsung Secret

Doc.No.	LTN156AT02-D	Rev.No	04-A01-S-081205	Page	12 / 30
---------	--------------	--------	-----------------	------	---------

4. BLOCK DIAGRAM

4.1 TFT LCD Module

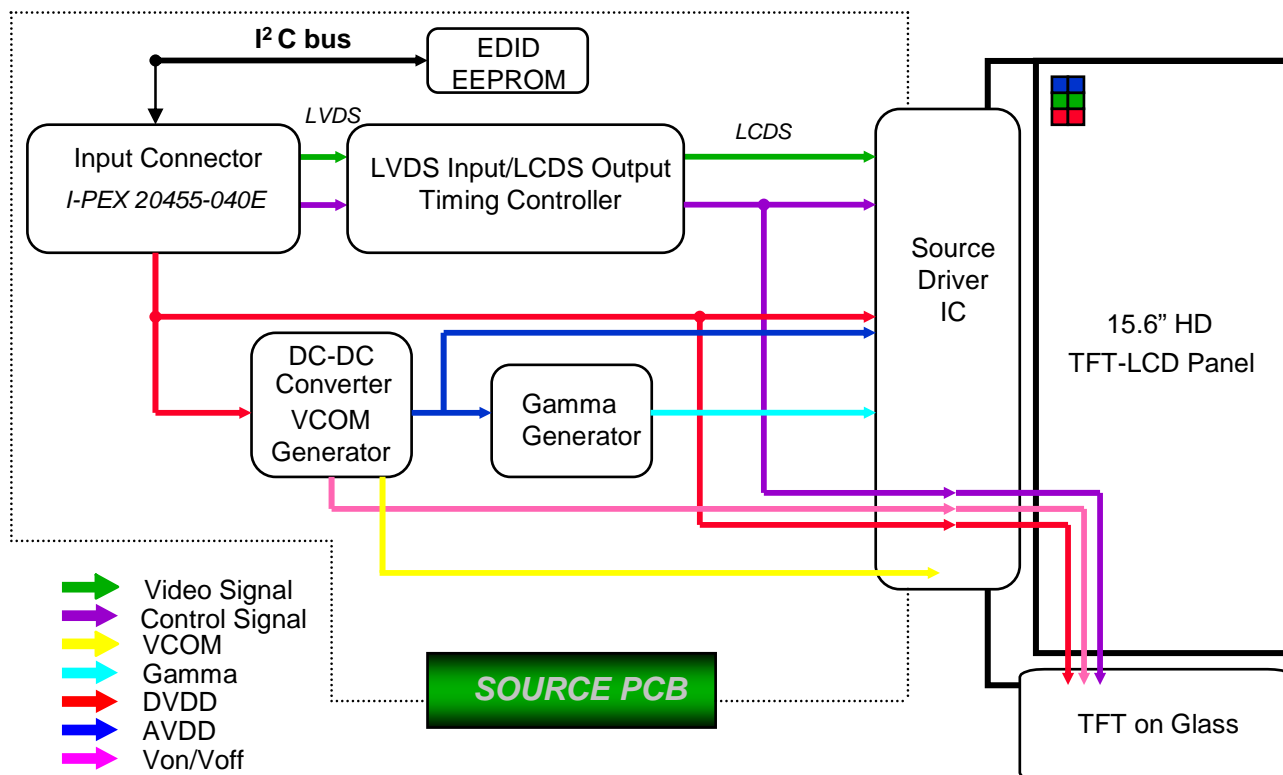

4.2 LED connection and placement

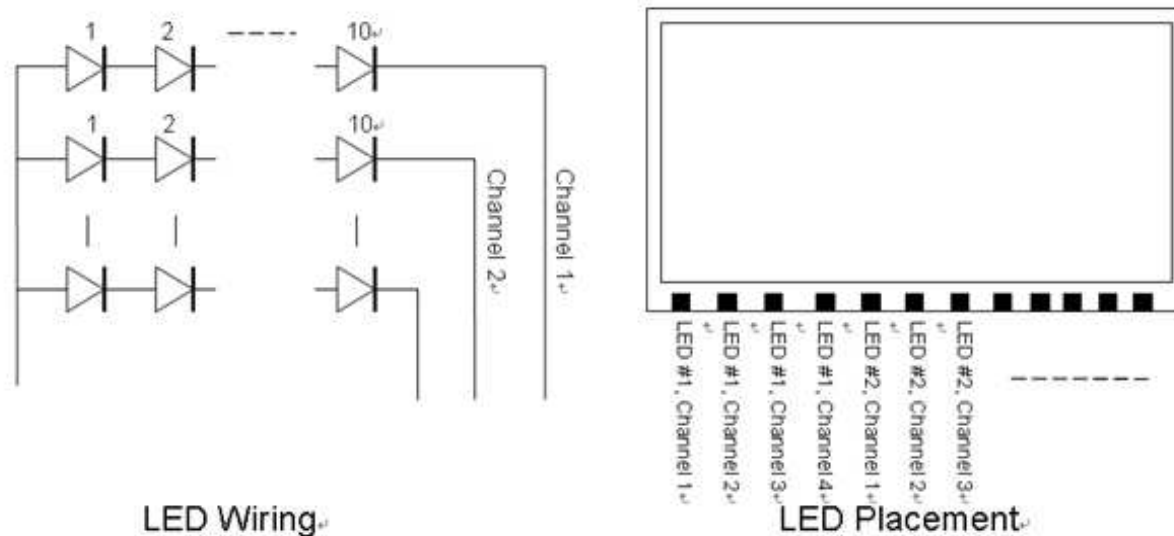

Samsung Secret

5. INPUT TERMINAL PIN ASSIGNMENT

5.1. Input Signal & Power (LVDS, Connector : I-PEX 20455-040E)

PIN #	Symbol	Description
1	DIAG_LOOP	Diag pin for Dell testing. Pin 1 & 34 must be connected
2	VDD	Power Supply, 3.3 V (typical)
3	VDD	Power Supply, 3.3 V (typical)
4	V EEDID	DDC 3.3V power
5	TEST	Panel Self Test
6	Clk EEDID	DDC Clock
7	DATA EEDID	DDC Data
8	Odd_Rin0-	- LVDS differential data input (R0-R5, G0) (odd pixels)
9	Odd_Rin0+	+ LVDS differential data input (R0-R5, G0) (odd pixels)
10	VSS	Ground – Shield
11	Odd_Rin1-	- LVDS differential data input (G1-G5, B0-B1) (odd pixels)
12	Odd_Rin1+	+ LVDS differential data input (G1-G5, B0-B1) (odd pixels)
13	VSS	Ground – Shield
14	Odd_Rin2-	- LVDS differential data input (B2-B5, HS, VS, DE) (odd pixels)
15	Odd_Rin2+	+ LVDS differential data input (B2-B5, HS, VS, DE) (odd pixels)
16	VSS	Ground – Shield
17	Odd_ClkIN-	- LVDS differential clock input (odd pixels)
18	Odd_ClkIN+	+ LVDS differential clock input (odd pixels)
19	NC	No connection
20	NC	No connection
21	NC	No connection
22	NC	No connection
23	NC	No connection
24	NC	No connection
25	NC	No connection

Samsung Secret

5. INPUT TERMINAL PIN ASSIGNMENT

5.1. Input Signal & Power (LVDS, Connector : I-PEX 20455-040E)

PIN #	Symbol	Description
26	NC	No connection
27	NC	No connection
28	NC	No connection
29	NC	No connection
30	NC	No connection
31	VSSLED	Ground – LED
32	VSSLED	Ground – LED
33	VSSLED	Ground – LED
34	DIAG_LOOP	Diag pin for Dell testing. Pin 1 & 34 must be connected
35	PWM	System PWM Signal Input (+3.3V Swing)
36	LED_EN	LED enable pin (+3.3V Input)
37	NC	NC
38	VDDLED	7.5V – 21V LED power
39	VDDLED	7.5V – 21V LED power
40	VDDLED	7.5V – 21V LED power

Samsung Secret

5.2 LVDS Interface : Transmitter DS90CF363 or Compatible

Pin No.	Name	RGB Signal	Pin No.	Name	RGB Signal
51	TxIN0	R0	14	TxIN14	G5
52	TxIN1	R1	15	TxIN15	B0
54	TxIN2	R2	19	TxIN18	B1
55	TxIN3	R3	20	TxIN19	B2
56	TxIN4	R4	22	TxIN20	B3
3	TxIN6	R5	23	TxIN21	B4
4	TxIN7	G0	24	TxIN22	B5
6	TxIN8	G1	27	TxIN24	Hsync
7	TxIN9	G2	28	TxIN25	Vsync
11	TxIN12	G3	30	TxIN26	DE
12	TxIN13	G4	31	TxCLKIN	Clock

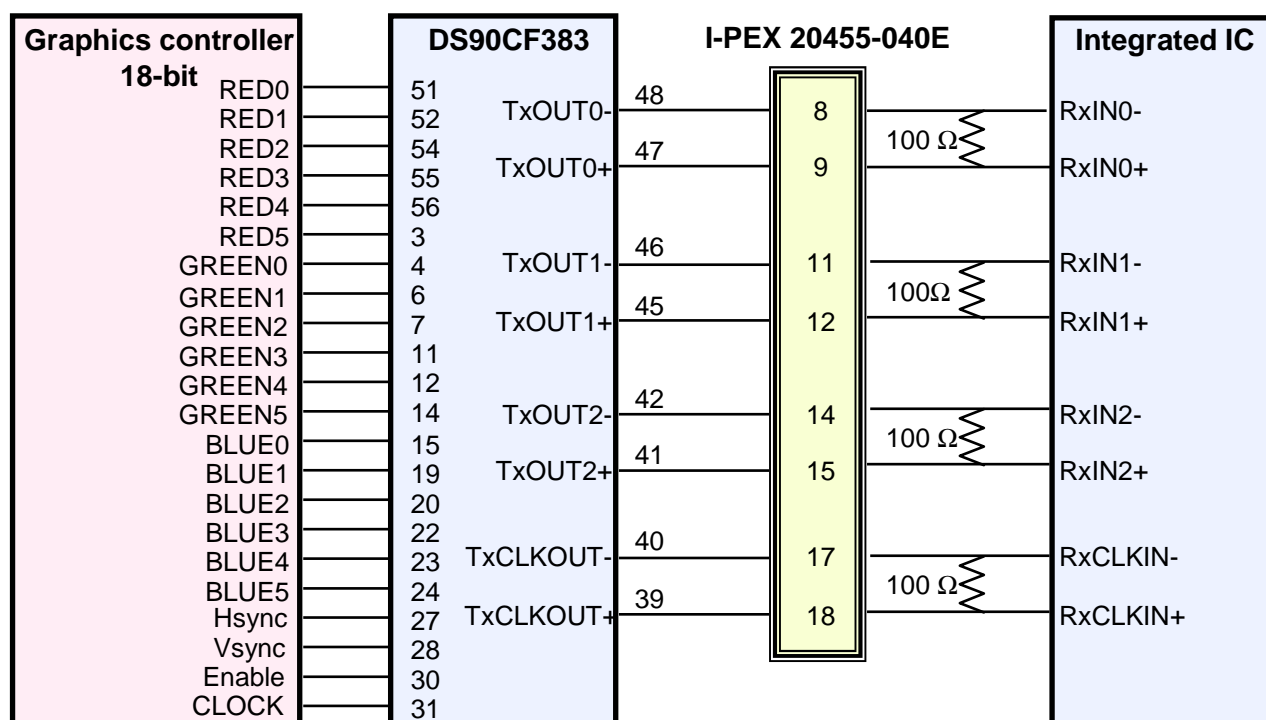
LVDS INTERFACE

Note : The LCD Module uses a 100ohm resistor between positive and negative lines of each receiver input.

Samsung Secret

5.3 Timing Diagrams of LVDS For Transmission

LVDS Receiver : Integrated T-CON

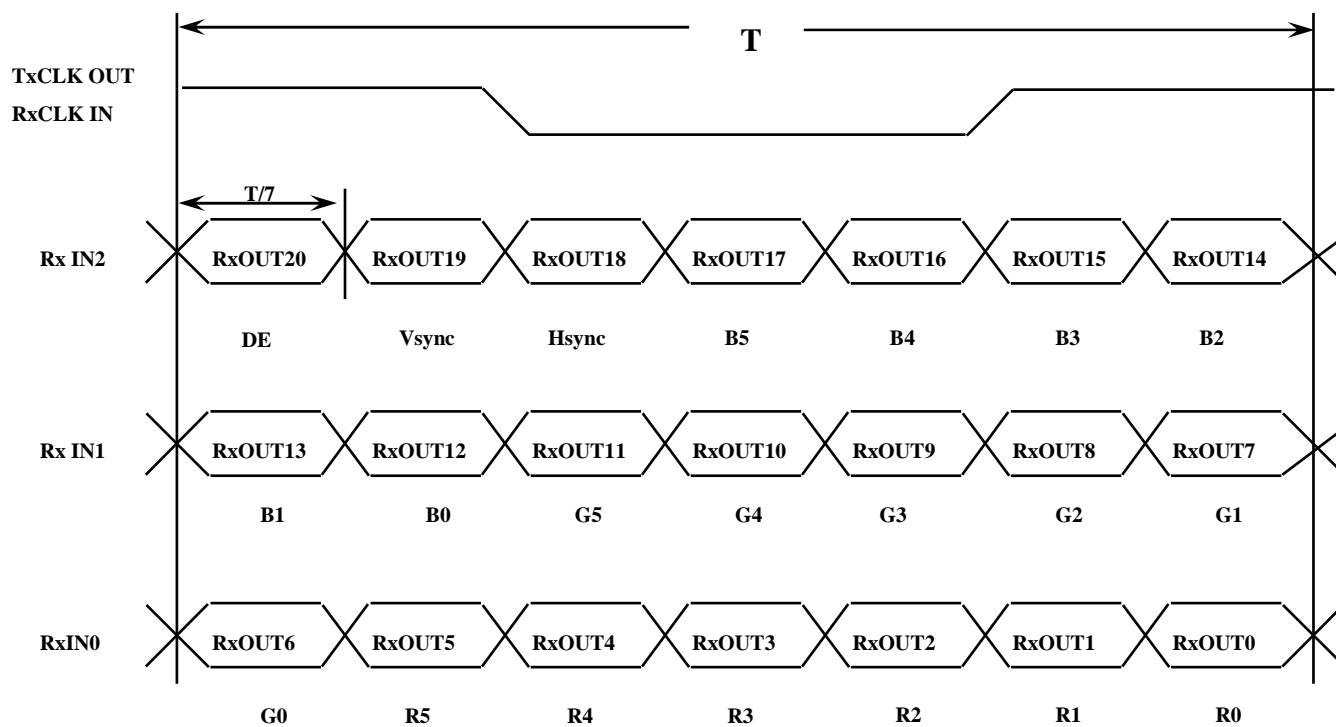

Samsung Secret

5.4 Input Signals, Basic Display Colors and Gray Scale of Each Color

Color	Display	Data Signal																Gray Scale Level	
		Red					Green					Blue							
		R0	R1	R2	R3	R4	R5	G0	G1	G2	G3	G4	G5	B0	B1	B2	B3		45
Basic Colors	Black	0	0	0	0	0	0	0	0	0	0	0	0	0	0	0	0	0	-
	Blue	0	0	0	0	0	0	0	0	0	0	0	0	1	1	1	1	1	-
	Green	0	0	0	0	0	0	1	1	1	1	1	1	0	0	0	0	0	-
	Cyan	0	0	0	0	0	0	1	1	1	1	1	1	1	1	1	1	1	-
	Red	1	1	1	1	1	1	0	0	0	0	0	0	0	0	0	0	0	-
	Magenta	1	1	1	1	1	1	0	0	0	0	0	0	1	1	1	1	1	-
	Yellow	1	1	1	1	1	1	1	1	1	1	1	1	0	0	0	0	0	-
	White	1	1	1	1	1	1	1	1	1	1	1	1	1	1	1	1	1	-
Gray Scale Of Red	Black	0	0	0	0	0	0	0	0	0	0	0	0	0	0	0	0	0	R0
	Dark	1	0	0	0	0	0	0	0	0	0	0	0	0	0	0	0	0	R1
	↑	0	1	0	0	0	0	0	0	0	0	0	0	0	0	0	0	0	R3~R60
	:	:	:	:	:	:	:	:	:	:	:	:	:	:	:	:	:	:	
	↓	1	0	1	1	1	1	0	0	0	0	0	0	0	0	0	0	0	R61
	Light	0	1	1	1	1	1	0	0	0	0	0	0	0	0	0	0	0	R62
	Red	1	1	1	1	1	1	0	0	0	0	0	0	0	0	0	0	0	R63
	Gray Scale Of Green	Black	0	0	0	0	0	0	0	0	0	0	0	0	0	0	0	0	0
Dark		0	0	0	0	0	0	1	0	0	0	0	0	0	0	0	0	0	G1
↑		0	0	0	0	0	0	0	1	0	0	0	0	0	0	0	0	0	G3~G60
:		:	:	:	:	:	:	:	:	:	:	:	:	:	:	:	:	:	
↓		0	0	0	0	0	0	1	0	1	1	1	1	0	0	0	0	0	G61
Light		0	0	0	0	0	0	0	1	1	1	1	1	0	0	0	0	0	G62
Green		0	0	0	0	0	0	1	1	1	1	1	1	0	0	0	0	0	G63
Gray Scale Of Blue		Black	0	0	0	0	0	0	0	0	0	0	0	0	0	0	0	0	0
	Dark	0	0	0	0	0	0	0	0	0	0	0	0	1	0	0	0	0	B1
	↑	0	0	0	0	0	0	0	0	0	0	0	0	0	1	0	0	0	B2
	:	:	:	:	:	:	:	:	:	:	:	:	:	:	:	:	:	:	B3~B60
	↓	0	0	0	0	0	0	0	0	0	0	0	0	1	0	1	1	1	
	Light	0	0	0	0	0	0	0	0	0	0	0	0	0	1	1	1	1	B62
	Blue	0	0	0	0	0	0	0	0	0	0	0	0	1	1	1	1	1	B63

Note 1) Definition of gray :

Rn: Red gray, Gn: Green gray, Bn: Blue gray (n=gray level)

Note 2) Input signal: 0 =Low level voltage, 1=High level voltage

Samsung Secret

5.5 Pixel Format in the display

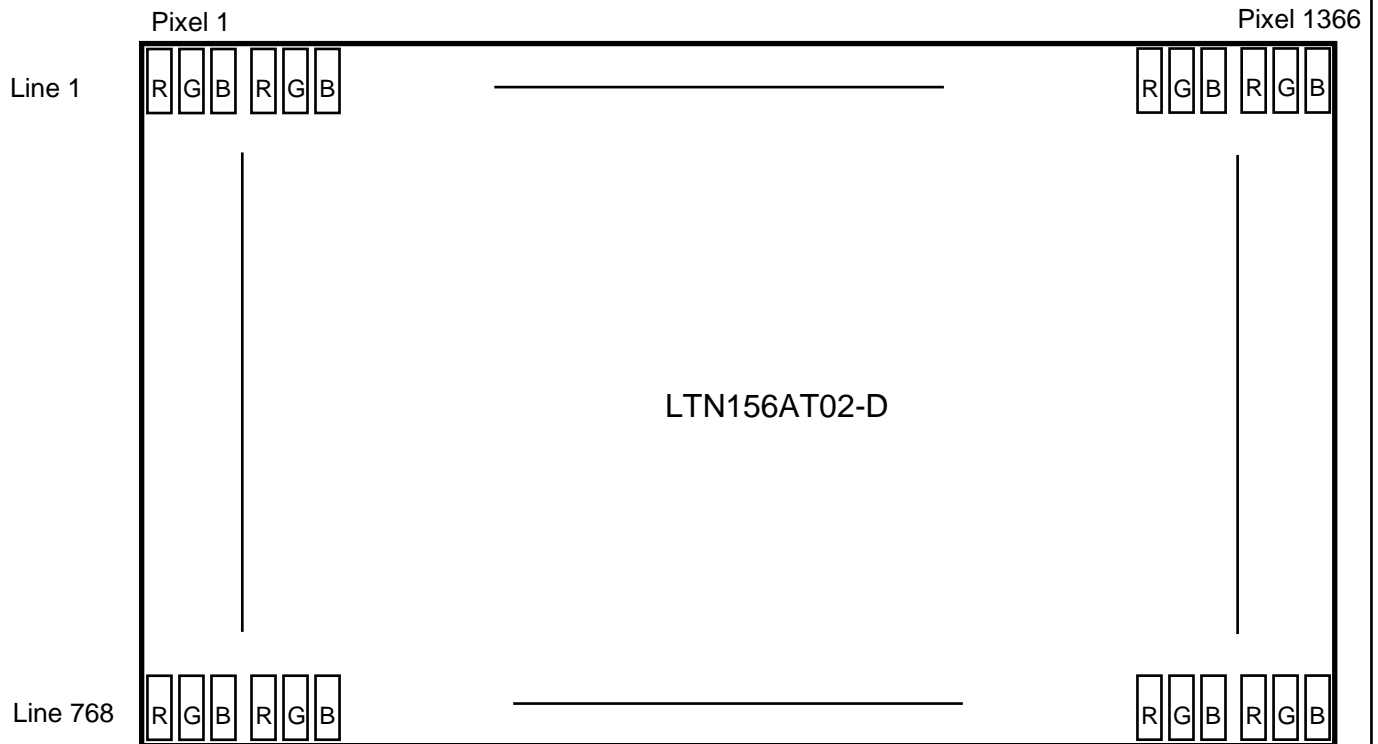
**Samsung Secret**

6. INTERFACE TIMING

6.1 Timing Parameters

Signal	Item	Symbol	Min.	Typ.	Max.	Unit	Note
Frame Frequency	Cycle	TV	-	790	-	Lines	-
Vertical Active Display Term	Display Period	TVD	-	768	-	Lines	-
One Line Scanning Time	Cycle	TH	-	1526	-	Clocks	-
Horizontal Active Display Term	Display Period	THD	-	1366	-	Clocks	-

6.2 Timing diagrams of interface signal

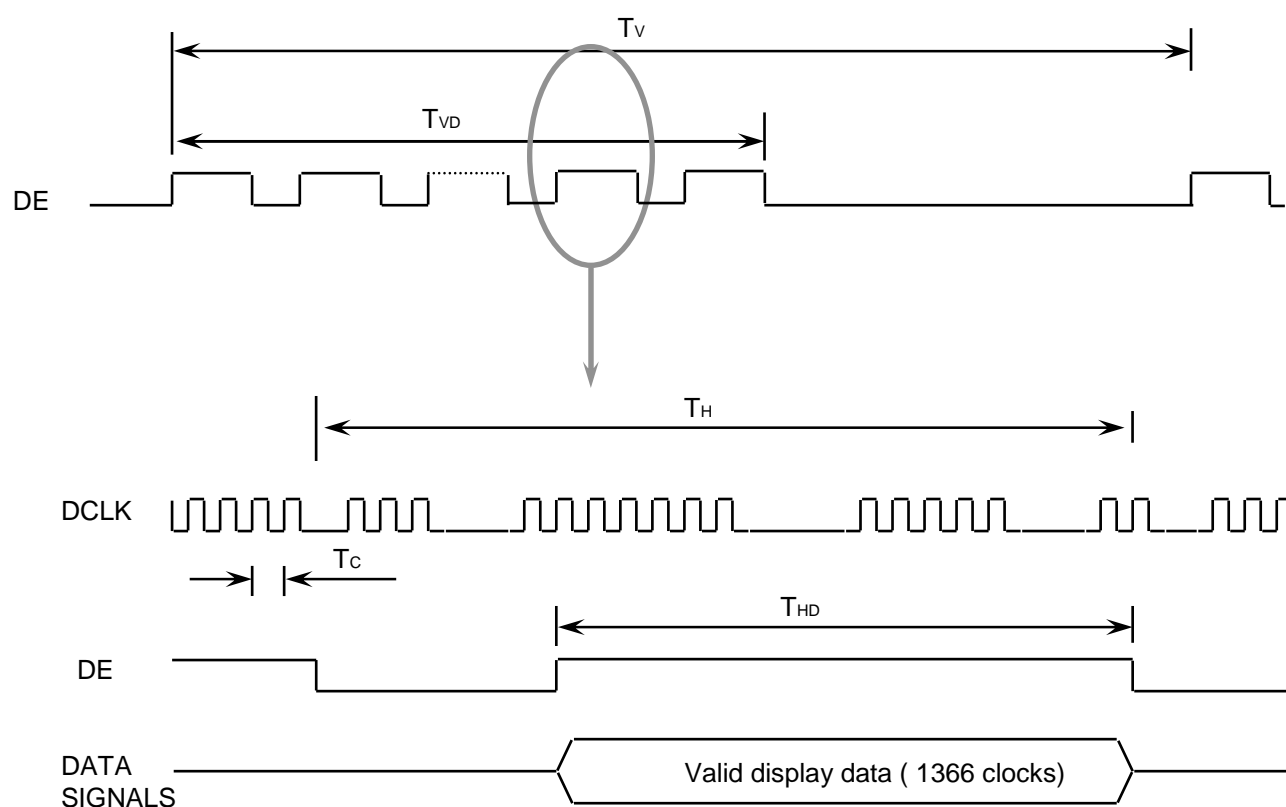

Samsung Secret

6.3 Power ON/OFF Sequence

Approval

: To prevent a latch-up or DC operation of the LCD module, the power on/off sequence should be as the diagram below.

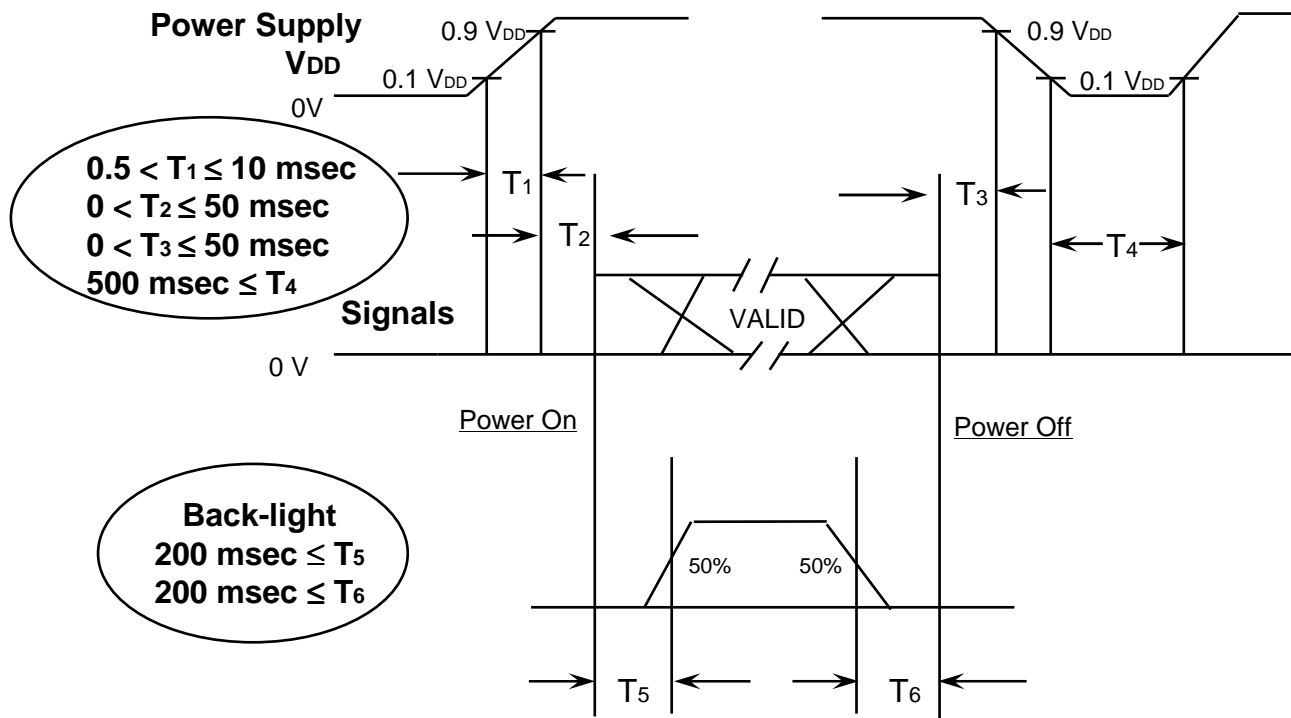

Power ON/OFF Sequence

- T1 : Vdd rising time from 10% to 90%
- T2 : The time from Vdd to valid data at power ON.
- T3 : The time from valid data off to Vdd off at power Off.
- T4 : Vdd off time for Windows restart
- T5 : The time from valid data to B/L enable at power ON.
- T6 : The time from valid data off to B/L disable at power Off.

NOTE.

- (1) The supply voltage of the external system for the module input should be the same as the definition of VDD.
- (2) Apply the lamp voltage within the LCD operation range. When the back-light turns on before the LCD operation or the LCD turns off before the back-light turns off, the display may momentarily become white.
- (3) In case of VDD = off level, please keep the level of input signals on the low or keep a high impedance.
- (4) T4 should be measured after the module has been fully discharged between power off and on period.
- (5) Interface signal shall not be kept at high impedance when the power is on.

Samsung Secret

Doc.No.	LTN156AT02-D	Rev.No	04-A01-S-081205	Page	21 / 30
---------	--------------	--------	-----------------	------	---------

7. MECHANICAL OUTLINE DIMENSION

Approval

It will be attached with PDF file

Samsung Secret

Doc.No.	LTN156AT02-D	Rev.No	04-A01-S-081205	Page	22 / 30
----------------	--------------	---------------	-----------------	-------------	---------

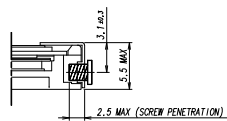
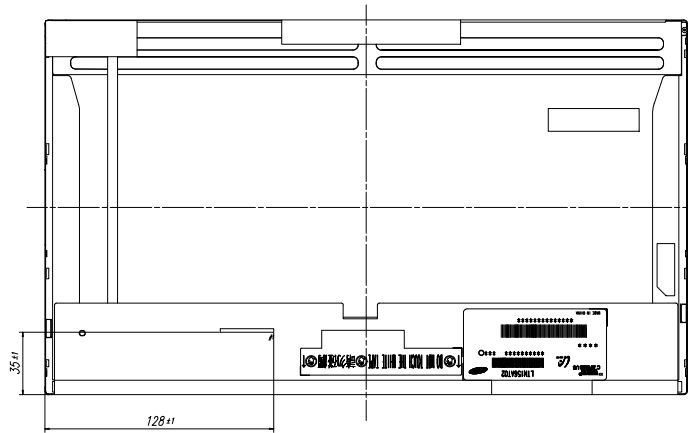
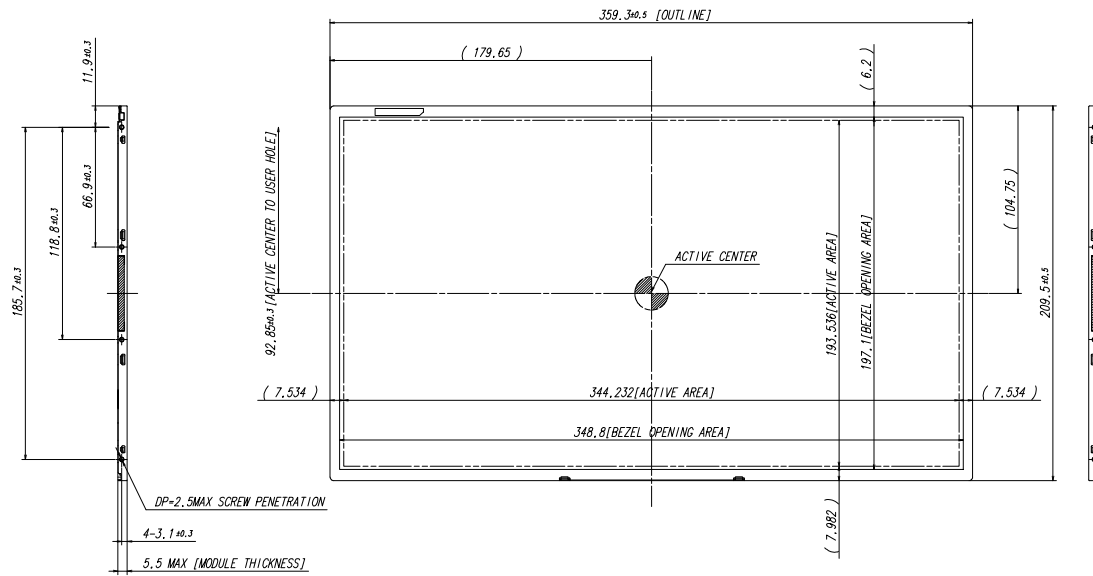

<USER HOLE SCREW PENETRATION DEPTH>

Approval

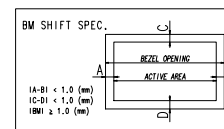

- * NOTE
1. SIGNAL INTERFACE CONNECTOR TO BE SPECIFIED AS BELOW.
 - MAKER : I-PEX OR COMPATIBLE
 - INPUT CONNECTOR : I-PEX 20455-#40#-## OR EQUIVALENT
 2. LED CONNECTOR FOR BACKLIGHT TO BE SPECIFIED AS BELOW.
 - MAKER : UJU Electronics
 - PART NO : 51441-1041
 3. TORQUE SPEC : MAX 2.5 Kgf-cm
 4. GENERAL TOLERANCE : ± 0.5

REV	DATE	DESCRIPTION OF REVISION	REASON	CHK'D BY
1	2016.04.14	INITIAL DESIGN BY CHECK BY APP'D BY		
2	2016.04.14	SCALE 1/22		
3	2016.04.14	SCALE 1/22		
4	2016.04.14	SCALE 1/22		
5	2016.04.14	SCALE 1/22		
6	2016.04.14	SCALE 1/22		
7	2016.04.14	SCALE 1/22		
8	2016.04.14	SCALE 1/22		
9	2016.04.14	SCALE 1/22		
10	2016.04.14	SCALE 1/22		
11	2016.04.14	SCALE 1/22		
12	2016.04.14	SCALE 1/22		
13	2016.04.14	SCALE 1/22		
14	2016.04.14	SCALE 1/22		
15	2016.04.14	SCALE 1/22		
16	2016.04.14	SCALE 1/22		
17	2016.04.14	SCALE 1/22		
18	2016.04.14	SCALE 1/22		
19	2016.04.14	SCALE 1/22		
20	2016.04.14	SCALE 1/22		
21	2016.04.14	SCALE 1/22		
22	2016.04.14	SCALE 1/22		
23	2016.04.14	SCALE 1/22		
24	2016.04.14	SCALE 1/22		
25	2016.04.14	SCALE 1/22		
26	2016.04.14	SCALE 1/22		
27	2016.04.14	SCALE 1/22		
28	2016.04.14	SCALE 1/22		
29	2016.04.14	SCALE 1/22		
30	2016.04.14	SCALE 1/22		
31	2016.04.14	SCALE 1/22		
32	2016.04.14	SCALE 1/22		
33	2016.04.14	SCALE 1/22		
34	2016.04.14	SCALE 1/22		
35	2016.04.14	SCALE 1/22		
36	2016.04.14	SCALE 1/22		
37	2016.04.14	SCALE 1/22		
38	2016.04.14	SCALE 1/22		
39	2016.04.14	SCALE 1/22		
40	2016.04.14	SCALE 1/22		
41	2016.04.14	SCALE 1/22		
42	2016.04.14	SCALE 1/22		
43	2016.04.14	SCALE 1/22		
44	2016.04.14	SCALE 1/22		
45	2016.04.14	SCALE 1/22		
46	2016.04.14	SCALE 1/22		
47	2016.04.14	SCALE 1/22		
48	2016.04.14	SCALE 1/22		
49	2016.04.14	SCALE 1/22		
50	2016.04.14	SCALE 1/22		
51	2016.04.14	SCALE 1/22		
52	2016.04.14	SCALE 1/22		
53	2016.04.14	SCALE 1/22		
54	2016.04.14	SCALE 1/22		
55	2016.04.14	SCALE 1/22		
56	2016.04.14	SCALE 1/22		
57	2016.04.14	SCALE 1/22		
58	2016.04.14	SCALE 1/22		
59	2016.04.14	SCALE 1/22		
60	2016.04.14	SCALE 1/22		
61	2016.04.14	SCALE 1/22		
62	2016.04.14	SCALE 1/22		
63	2016.04.14	SCALE 1/22		
64	2016.04.14	SCALE 1/22		
65	2016.04.14	SCALE 1/22		
66	2016.04.14	SCALE 1/22		
67	2016.04.14	SCALE 1/22		
68	2016.04.14	SCALE 1/22		
69	2016.04.14	SCALE 1/22		
70	2016.04.14	SCALE 1/22		
71	2016.04.14	SCALE 1/22		
72	2016.04.14	SCALE 1/22		
73	2016.04.14	SCALE 1/22		
74	2016.04.14	SCALE 1/22		
75	2016.04.14	SCALE 1/22		
76	2016.04.14	SCALE 1/22		
77	2016.04.14	SCALE 1/22		
78	2016.04.14	SCALE 1/22		
79	2016.04.14	SCALE 1/22		
80	2016.04.14	SCALE 1/22		
81	2016.04.14	SCALE 1/22		
82	2016.04.14	SCALE 1/22		
83	2016.04.14	SCALE 1/22		
84	2016.04.14	SCALE 1/22		
85	2016.04.14	SCALE 1/22		
86	2016.04.14	SCALE 1/22		
87	2016.04.14	SCALE 1/22		
88	2016.04.14	SCALE 1/22		
89	2016.04.14	SCALE 1/22		
90	2016.04.14	SCALE 1/22		
91	2016.04.14	SCALE 1/22		
92	2016.04.14	SCALE 1/22		
93	2016.04.14	SCALE 1/22		
94	2016.04.14	SCALE 1/22		
95	2016.04.14	SCALE 1/22		
96	2016.04.14	SCALE 1/22		
97	2016.04.14	SCALE 1/22		
98	2016.04.14	SCALE 1/22		
99	2016.04.14	SCALE 1/22		
100	2016.04.14	SCALE 1/22		

8. PACKING

1. CARTON(Internal Package)

(1) Packing Form

Corrugated Cardboard box and Corrupad form as shock absorber

(2) Packing Method

CUSHION BOTTOM

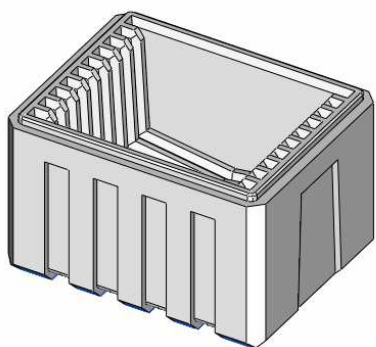

PANEL : 2EA/SLIT

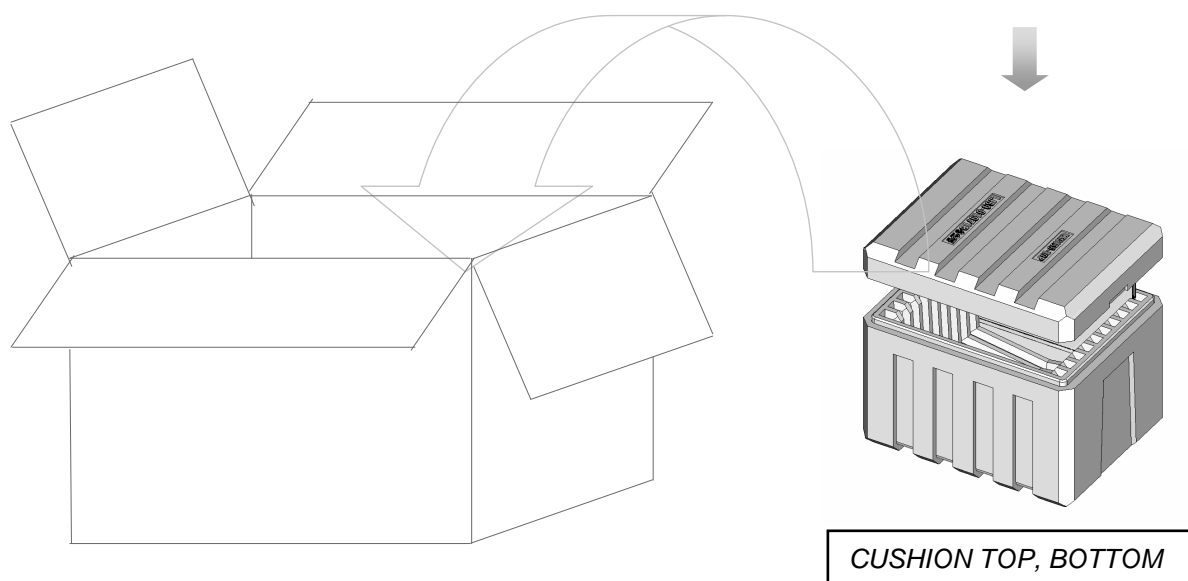
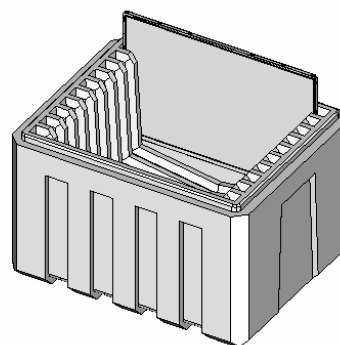

Note (1) Total : Approx. 12400g

(2) Acceptance number of piling : 20 sets

(3) Carton size : 344(W) X 432(D) X 329(H)

Samsung Secret

No	Part name	Quantity
1	Static electric protective sack	10
2	Packing case (Inner box) included shock absorber	1 set
3	Pictorial marking	2 pcs
4	Carton	1 set

9. MARKINGS & OTHERS

A nameplate bearing followed by is affixed to a shipped product at the specified location on each product.

(1) Parts number : LTNXXXXXXXX-XXX

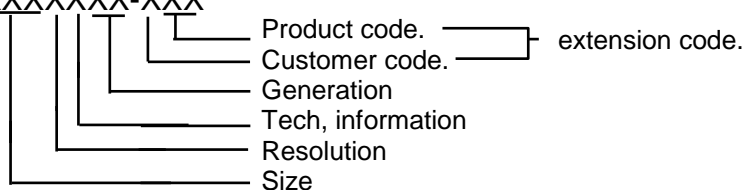

(2) Revision : Three letters

(3) Lot number : X Y 7 A XXX XX X

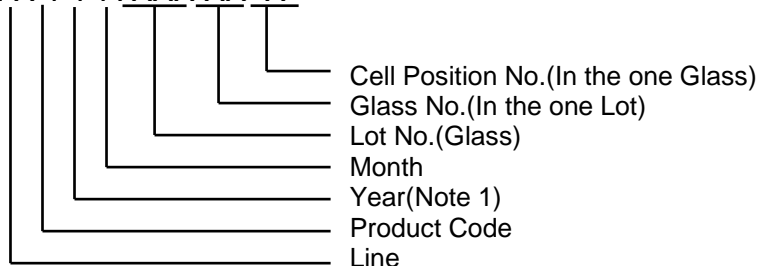

NOTE 1). This code indicating year is omitted in the products of KIHEUNG site.

(5) Nameplate Indication(Following example is only for reference)

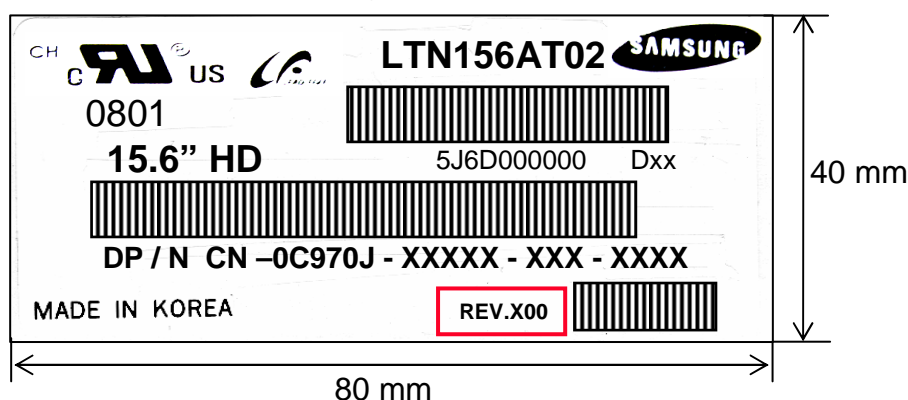

Parts name : LTN156AT02-D
Lot number : 5J6D000000
Inspected work week : 0801 Number ("0C970J" is for 156AT02-D)
DP/N : Dell Part
REV.X00 : Product Revision Code

Samsung Secret

Doc.No.	LTN156AT02-D	Rev.No	04-A01-S-081205	Page	24 / 30
---------	--------------	--------	-----------------	------	---------

This HIGH VOLTAGE CAUTION is carved in mold frame

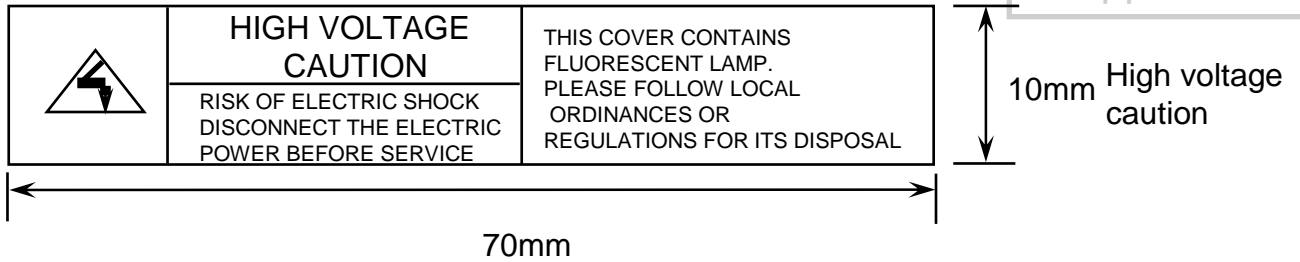

※ Panel revision code scheme (Refer to the Red box on the label)

Build Name(s)	Revision Code(s)
SST (WS)	X00, X01, X02, ... X09
PT (ES)	X10, X11, X12, ... X19
ST (CS)	X20, X21, X23, ... X29
XB (MP)	A00, A01, A02, ... A99

(6) Packing small box attach (Following example is only for reference)

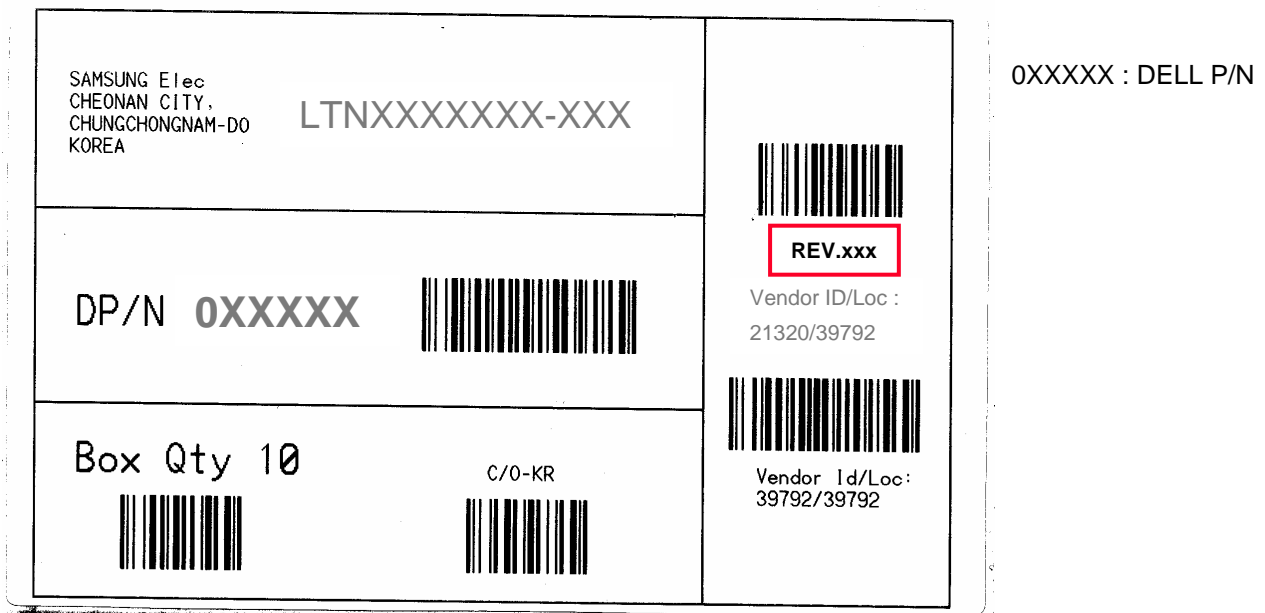

(7) Packing box Marking : Samsung TFT-LCD Brand Name



Samsung Secret

10. GENERAL PRECAUTIONS

Approval

1. Handling

- (a) When the module is assembled, It should be attached to the system firmly using every mounting holes. Be careful not to twist and bend the modules.
- (b) Refrain from strong mechanical shock and / or any force to the module. In addition to damage, this may cause improper operation or damage to the module.
- (c) Note that polarizers are very fragile and could be easily damaged. Do not press or scratch the surface harder than a HB pencil lead.
- (d) Wipe off water droplets or oil immediately. If you leave the droplets for a long time, Staining and discoloration may occur.
- (e) If the surface of the polarizer is dirty, clean it using some absorbent cotton or soft cloth.
- (f) The desirable cleaners are water, IPA (Isopropyl Alcohol) or Hexane. Do not use Ketone type materials(ex. Acetone), Ethyl alcohol, Toluene, Ethyl acid or Methyl chloride. It might permanent damage to the polarizer due to chemical reaction.
- (g) If the liquid crystal material leaks from the panel, it should be kept away from the eyes or mouth. In case of contact with hands, legs or clothes, it must be washed away thoroughly with soap.
- (h) Protect the module from static, it may cause damage to the C-MOS Gate Array IC.
- (i) Use fingerstalls with soft gloves in order to keep display clean during the incoming inspection and assembly process.
- (j) Do not disassemble the module.
- (k) Do not pull or fold the lamp wire.
- (l) Do not adjust the variable resistor which is located on the back side.
- (m) Protection film for polarizer on the module shall be slowly peeled off just before use so that the electrostatic charge can be minimized.
- (n) Pins of I/F connector shall not be touched directly with bare hands.

Samsung Secret

Doc.No.	LTN156AT02-D	Rev.No	04-A01-S-081205	Page	26 / 30
----------------	--------------	---------------	-----------------	-------------	---------

2. STORAGE

- (a) Do not leave the module in high temperature, and high humidity for a long time.
It is highly recommended to store the module with temperature from 0 to 35 °C and relative humidity of less than 70%.
- (b) Do not store the TFT-LCD module in direct sunlight.
- (c) The module shall be stored in a dark place. It is prohibited to apply sunlight or fluorescent light during the store.

3. OPERATION

- (a) Do not connect,disconnect the module in the “ Power On” condition.
- (b) Power supply should always be turned on/off by following item 6.3
“ Power on/off sequence “.
- (c) Module has high frequency circuits. Sufficient suppression to the electromagnetic interference shall be done by system manufacturers. Grounding and shielding methods may be important to minimize the interference.
- (d) The standard limited warranty is only applicable when the module is used for general notebook applications. If used for purposes other than as specified, SEC is not to be held reliable for the defective operations. It is strongly recommended to contact SEC to find out fitness for a particular purpose.

4. OTHERS

- (a) Ultra-violet ray filter is necessary for outdoor operation.
- (b) Avoid condensation of water. It may result in improper operation or disconnection of electrode.
- (c) Do not exceed the absolute maximum rating value. (the supply voltage variation, input voltage variation, variation in part contents and environmental temperature, so on)
Otherwise the module may be damaged.
- (d) If the module displays the same pattern continuously for a long period of time,it can be the situation when the image “sticks” to the screen.
- (e) This module has its circuitry PCB's on the rear side and should be handled carefully in order not to be stressed.

Samsung Secret

Doc.No.	LTN156AT02-D	Rev.No	04-A01-S-081205	Page	27 / 30
----------------	--------------	---------------	-----------------	-------------	---------

	Byte	Field Name and Comments	Value	Value
	(hex)		(hex)	(binary)
Header	0	Header	00	00000000
	1	Header	FF	11111111
	2	Header	FF	11111111
	3	Header	FF	11111111
	4	Header	FF	11111111
	5	Header	FF	11111111
	6	Header	FF	11111111
	7	Header	00	00000000
Vendor / Product EDID Version	8	EISA manufacture code = 3 Character ID	4C	01001100
	9	EISA manufacture code (Compressed ASCII)	A3	10100011
	0A	Panel Supplier Reserved - Product Code	41	01000001
	0B	Panel Supplier Reserved - Product Code	54	01010100
	0C	LCD module Serial No - Preferred but Optional ("0" if not used)	00	00000000
	0D	LCD module Serial No - Preferred but Optional ("0" if not used)	00	00000000
	0E	LCD module Serial No - Preferred but Optional ("0" if not used)	00	00000000
	0F	LCD module Serial No - Preferred but Optional ("0" if not used)	00	00000000
	10	Week of manufacture	00	00000000
	11	Year of manufacture	12	00010010
	12	EDID structure version # = 1	01	00000001
	13	EDID revision # = 3	03	00000011
	Display Parameters	14	Video I/P definition = Digital I/P	90
15		Max H image size = (Rounded to cm)	22	00100010
16		Max V image size = (Rounded to cm)	13	00010011
17		Display gamma = (gamma × 100) - 100 = Example: (2.2 × 100) - 100 = 120	78	01111000
18		Feature support (no DPMS, Active off, RGB, timing BLK 1)	0A	00001010
Panel Color Coordinates	19	Red/Green Low bit (RxRy/GxGy)	87	10000111
	1A	Blue/White Low bit (BxBy/WxWy)	F5	11110101
	1B	Red X Rx = 0.xxx	94	10010100
	1C	Red Y Ry = 0.xxx	57	01010111
	1D	Green X Gx = 0.xxx	4F	01001111
	1E	Green Y Gy = 0.xxx	8C	10001100
	1F	Blue X Bx = 0.xxx	27	00100111
	20	Blue Y By = 0.xxx	27	00100111
	21	White X Wx = 0.xxx	50	01010000
	22	White Y Wy = 0.xxx	54	01010100
Established Timings	23	Established timings 1 (00h if not used)	00	00000000
	24	Established timings 2 (00h if not used)	00	00000000
	25	Manufacturer's timings (00h if not used)	00	00000000

Samsung Secret

Standard Timing ID	26	Standard timing ID1 (01h if not used)	01	00000001	
	27	Standard timing ID1 (01h if not used)	01	00000001	
	28	Standard timing ID2 (01h if not used)	01	00000001	
	29	Standard timing ID2 (01h if not used)	01	00000001	
	2A	Standard timing ID3 (01h if not used)	01	00000001	
	2B	Standard timing ID3 (01h if not used)	01	00000001	
	2C	Standard timing ID4 (01h if not used)	01	00000001	
	2D	Standard timing ID4 (01h if not used)	01	00000001	
	2E	Standard timing ID5 (01h if not used)	01	00000001	
	2F	Standard timing ID5 (01h if not used)	01	00000001	
	30	Standard timing ID6 (01h if not used)	01	00000001	
	31	Standard timing ID6 (01h if not used)	01	00000001	
	32	Standard timing ID7 (01h if not used)	01	00000001	
	33	Standard timing ID7 (01h if not used)	01	00000001	
	34	Standard timing ID8 (01h if not used)	01	00000001	
	35	Standard timing ID8 (01h if not used)	01	00000001	
Timing Descriptor #1	36	Pixel Clock/10,000 (LSB)	41	01000001	
	37	Pixel Clock/10,000 (MSB)	1C	00011100	
	38	Horizontal Active = xxxx pixels (lower 8 bits)	56	01010110	
	39	Horizontal Blanking (Thbp) = xxxx pixels (lower 8 bits)	A0	10100000	
	3A	Horizontal Active/Horizontal blanking (Thbp) (upper 4:4 bits)	50	01010000	
	3B	Vertical Active = xxxx lines	00	00000000	
	3C	Vertical Blanking (Tvbp) = xxxx lines (DE Blanking typ. for DE only panels)	16	00010110	
	3D	Vertical Active : Vertical Blanking (Tvbp) (upper 4:4 bits)	30	00110000	
	3E	Horizontal Sync, Offset (Thfp) = xxxx pixels	30	00110000	
	3F	Horizontal Sync, Pulse Width = xxxx pixels	20	00100000	
	40	Vertical Sync, Offset (Tvfp) = xx lines Sync Width = xx lines	25	00100101	
	41	Horizontal Vertical Sync Offset/Width upper 2 bits	00	00000000	
	42	Horizontal Image Size =xxx mm	61	01100001	
	43	Vertical image Size = xxx mm	C6	11000110	
	44	Horizontal Image Size / Vertical image size	10	00010000	
	45	Horizontal Border = 0 (Zero for Notebook LCD)	00	00000000	
	46	Vertical Border = 0 (Zero for Notebook LCD)	00	00000000	
	47	Bit[7] 0: Non-interlace, 1: Interlace Bit[6:5] 00: Normal display, no stereo, XX: See table xx for definition Bit[4:3] 00: Analog composite, 01: Bipolar analog composite, 10: Digital composite, 11: Digital separate Bit[2:1] :The interpretation of bits 2 and 1 is dependent on the decode of bits 4 and 3 - see Table 3.18. Bit[0] :See Table VESA EDID spec for definition Referenced Default = 1Ah	1A	00011010	
	Timing Descriptor #2	48	Pixel Clock/10,000 (LSB)	41	01000001
		49	Pixel Clock/10,000 (MSB)	1C	00011100
4A		Horizontal Active = xxxx pixels (lower 8 bits)	56	01010110	
4B		Horizontal Blanking (Thbp) = xxxx pixels (lower 8 bits)	A0	10100000	
4C		Horizontal Active/Horizontal blanking (Thbp) (upper 4:4 bits)	50	01010000	
4D		Vertical Active = xxxx lines	00	00000000	
4E		Vertical Blanking (Tvbp) = xxxx lines (DE Blanking typ. for DE only panels)	16	00010110	
4F		Vertical Active : Vertical Blanking (Tvbp) (upper 4:4 bits)	30	00110000	
50		Horizontal Sync, Offset (Thfp) = xxxx pixels	30	00110000	
51		Horizontal Sync, Pulse Width = xxxx pixels	20	00100000	
52		Vertical Sync, Offset (Tvfp) = xx lines Sync Width = xx lines	25	00100101	
53		Horizontal Vertical Sync Offset/Width upper 2 bits	00	00000000	
54		Horizontal Image Size =xxx mm	58	01011000	
55		Vertical image Size = xxx mm	C2	11000010	
56		Horizontal Image Size / Vertical image size	10	00010000	
57		Horizontal Border = 0 (Zero for Notebook LCD)	00	00000000	
58	Vertical Border = 0 (Zero for Notebook LCD)	00	00000000		
59	Bit[7] 0: Non-interlace, 1: Interlace Bit[6:5] 00: Normal display, no stereo, XX: See table xx for definition Bit[4:3] 00: Analog composite, 01: Bipolar analog composite, 10: Digital composite, 11: Digital separate Bit[2:1] :The interpretation of bits 2 and 1 is dependent on the decode of bits 4 and 3 - see Table 3.18. Bit[0] :See Table VESA EDID spec for definition Referenced Default = 1Ah	1A	00011010		

Samsung Secret

Timing Descriptor #3 Dell specific information	5A	Flag	00	00000000
	5B	Flag	00	00000000
	5C	Flag	00	00000000
	5D	Data Type Tag: Alphanumeric Data String (ASCII)	FE	11111110
	5E	Flag	00	00000000
	5F	Dell P/N 1 st Character	43	01000011
	60	Dell P/N 2 nd Character	39	00111001
	61	Dell P/N 3 rd Character	37	00110111
	62	Dell P/N 4 th Character	30	00110000
	63	Dell P/N 5 th Character	4A	01001010
	64	LCD Supplier EEDID Revision # Bit[7] : 0=X, 1=A Bit[6:0] : 00, 01, 02... for SST 10, 11, 12... for PT 20, 21, 22... for ST 00, 01, 02... for X-Build (if Bit[7]=1)	80	10000000
	65	Manufacturer P/N	31	00110001
	66	Manufacturer P/N	35	00110101
	67	Manufacturer P/N	36	00110110
	68	Manufacturer P/N	41	01000001
	69	Manufacturer P/N	54	01010100
6A	Manufacturer P/N	0A	00001010	
6B	Manufacturer P/N (If <13 char, then terminate with ASCII code 0Ah, set remaining char = 20h)	20	00100000	
Timing Descriptor #4	6C	Flag	00	00000000
	6D	Flag	00	00000000
	6E	Flag	00	00000000
	6F	Data Type Tag: Manufacturer Specified Data 00	00	00000000
	70	Flag	00	00000000
	71	SMBUS Value = XX nits	00	00000000
	72	SMBUS Value = XX nits	00	00000000
	73	SMBUS Value = XX nits	00	00000000
	74	SMBUS Value = XX nits	00	00000000
	75	SMBUS Value = XX nits	00	00000000
	76	SMBUS Value = XXX nits	00	00000000
	77	SMBUS Value = XXX nits	00	00000000
	78	SMBUS Value = max nits (Typically = 00h, XXX nits)	00	00000000
	79	Bit[7:3] Reserved Bit[2] 0: No RTC support, 1: RTC support Bit[1:0] 00: reserved, 01: single LVDS, 10: dual LVDS, 11: reserved 01h single channel LVDS, no RTC support 02h dual channel LVDS, no RTC support 05h single channel LVDS, with RTC support 06h dual channel LVDS, with RTC support	01	00000001
	7A	BIST Enable: Yes = '01' No = '00'	01	00000001
	7B	(If <13 char, then terminate with ASCII code 0Ah, set remaining char = 20h)	0A	00001010
7C	(If <13 char, then terminate with ASCII code 0Ah, set remaining char = 20h)	20	00100000	
7D	(If <13 char, then terminate with ASCII code 0Ah, set remaining char = 20h)	20	00100000	
Checksum	7E	Extension flag (# of optional 128 EDID extension blocks to follow, Typ = 0)	00	00000000
	7F	Checksum (The 1-byte sum of all 128 bytes in this EDID block shall = 0)	3E	00111110

Samsung Secret