

mass integrated

global part distribution • product lifecycle partner
excess inventory management • value-ad service provider



Data sheet provided by Mass Integrated

massintegrated.com • displayalliance.com

Please call +1.978.465.6190
Email: sales@massintegrated.com



ISO 9001: 2008

Mass Integrated complies with all DMCA takedown notices. Please send a formal DMCA Takedown Notice to Mass Integrated Systems, Inc. • 18 Henry Graf Jr. Road, Unit 1 • Newburyport, MA 01950.



ELECTRONICS

Approval



TO :
DATE : June. 25. 2010

SAMSUNG TFT-LCD
MODEL NO : LTN156AT02-

NOTE : Extension code [-]
→ LTN156AT02-
Surface type [Glare, True life]

The information described in this SPEC is preliminary and can be changed without prior notice.

Application engineering part, Mobile Division
Samsung Electronics Co., Ltd.

Doc.No.	LTN156AT02-	Rev.No	04-A00-S-100625	Page	1 / 27
----------------	-------------	---------------	-----------------	-------------	--------

CONTENTS

Revision History	-----	(3)
General Description	-----	(4)
1. Absolute Maximum Ratings	-----	(5)
1.1 Absolute Ratings of environment		
1.2 Electrical Absolute Ratings		
2. Optical Characteristics	-----	(7)
3. Electrical Characteristics	-----	(10)
3.1 TFT LCD Module		
3.2 Backlight Unit		
3.3 LED Driver		
4. Block Diagram	-----	(13)
4.1 TFT LCD Module		
5. Input Terminal Pin Assignment	-----	(14)
5.1 Input Signal & Power		
5.2 LVDS Interface		
5.3 Timing Diagrams of LVDS For Transmitting		
5.4 Input Signals, Basic Display Colors and Gray Scale of Each Color.		
5.5 Pixel format		
6. Interface Timing	-----	(19)
6.1 Timing Parameters		
6.2 Timing Diagrams of interface Signal		
6.3 Power ON/OFF Sequence		
7. Outline Dimension	-----	(21)
8. Packing	-----	(22)
9. Markings & Others	-----	(23)
10. General Precautions	-----	(25)
11. EDID	-----	(28)

REVISION HISTORY

Approval

Date	Revision No.	Page	Summary
June. 25. 2010	A00	All	LTN156AT02- model spec was issued first.

GENERAL DESCRIPTION

DESCRIPTION

LTN156AT02- is a color active matrix TFT (Thin Film Transistor) liquid crystal display (LCD) that uses amorphous silicon TFT as switching devices. This model is composed of a TFT LCD panel, a driver circuit and a backlight system. The resolution of a 15.6" contains 1366 x 768 pixels and can display up to 262,144 colors. 6 O'clock direction is the Optimum viewing angle.

FEATURES

- Thin and light weight
- High contrast ratio, high aperture structure
- 1366 x 768 pixels resolution (16:9)
- Fast Response Time
- Low power consumption
- LED BLU Structure
- DE (Data enable) only mode
- 3.3V LVDS Interface
- On board EDID chip
- Pb-free product

APPLICATIONS

- Notebook PC
- If the usage of this product is not for PC application, but for others, please contact SEC

GENERAL INFORMATION

Item	Specification	Unit	Note
Display area	344.232 (H) x 193.536 (V) (15.6"diagonal)	mm	
Driver element	a-Si TFT active matrix		
Display colors	262,144		
Number of pixel	1366 x 768	pixel	16 : 9
Pixel arrangement	RGB vertical stripe		
Pixel pitch	0.252 (H) x 0.252 (V) (TYP.)	mm	
Display Mode	Normally white		
Surface treatment	Haze 0, Hardness 3H		Glare

Mechanical Information

Item		Min.	Typ.	Max.	Unit	Note
Module size	Horizontal (H)	358.8	359.3	359.8	mm	
	Vertical (V)	209.0	209.5	210	mm	
	Depth (D)	-	-	5.5	mm	(1)
Weight		-	-	450	g	

Note (1) Measurement condition of outline dimension

- . Equipment : Vernier Calipers
- . Push Force : 500g · f (minimum)

1. ABSOLUTE MAXIMUM RATINGS

1.1 ENVIRONMENTAL ABSOLUTE RATINGS

Item	Symbol	Min.	Max.	Unit	Note
Storage temperate	TSTG	-20	60	C	(1)
Operating temperate (Temperature of glass surface)	TOPR	0	50	C	(1)
Shock (non-operating)	Snop	-	240	G	(2),(4)
Vibration (non-operating)	Vnop	-	2.41	G	(3),(4)

Note (1) Temperature and relative humidity range are shown in the figure below.

95 % RH Max. ($40\text{ }^{\circ}\text{C} \geq T_a$)

Maximum wet - bulb temperature at $39\text{ }^{\circ}\text{C}$ or less. ($T_a > 40\text{ }^{\circ}\text{C}$) No condensation

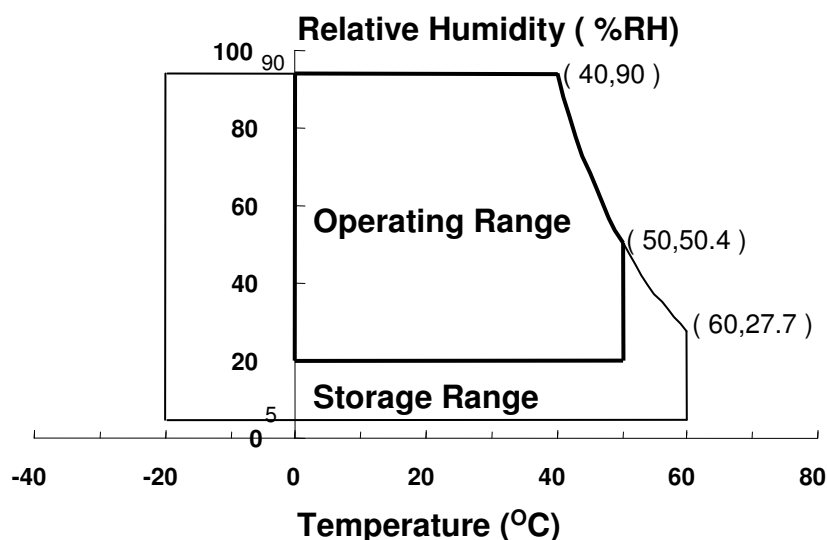

(2) 2ms, half sine wave, one time for $\pm X$, $\pm Y$, $\pm Z$.

(3) 5 - 500 Hz, random vibration, 30min for X, Y, Z.

(4) At testing Vibration and Shock, the fixture in holding the Module to be tested have to be hard and rigid enough so that the Module would not be twisted or bent by the fixture.

1.2 ELECTRICAL ABSOLUTE RATINGS

(1) TFT LCD MODULE

 $V_{DD} = 3.3V, V_{SS} = GND = 0V$

Item	Symbol	Min.	Max.	Unit	Note
Power Supply Voltage	V_{DD}	$V_{DD} - 0.3$	$V_{DD} + 0.3$	V	(1)
Logic Input Voltage	V_{DD}	$V_{DD} - 0.3$	$V_{DD} + 0.3$	V	(1)

Note (1) Within T_a (25 ± 2 C)

2. OPTICAL CHARACTERISTICS

The following items are measured under stable conditions. The optical characteristics should be measured in a dark room or equivalent state with the methods shown in Note (5).
Measuring equipment : TOPCON SR-3

* Ta = 25 ± 2 C, V_{DD}=3.3V, f_v= 60Hz, f_{DCLK} = 72.33 MHz, I_L = 20 mA

Item	Symbol	Condition	Min.	Typ.	Max	Unit	Note	
Contrast Ratio (5 Points)	CR	Normal Viewing Angle φ = 0 θ = 0	500	600	-	-	(1), (2), (5)	
Response Time at Ta (Rising + Falling)	T _{RT}		-	25	35	msec	(1), (3)	
Average Luminance of White (5 Points)	Y _{L,AVE}		200	220	-	cd/m ²	I _L =19mA (1), (4)	
Color Chromaticity (CIE)	Red		R _X	0.590	0.620	0.650	-	
			R _Y	0.310	0.340	0.370		
	Green		G _X	0.300	0.330	0.360		
			G _Y	0.540	0.570	0.600		
	Blue		B _X	0.120	0.150	0.180		
			B _Y	0.030	0.060	0.090		
	White		W _X	0.283	0.313	0.343		
		W _Y	0.299	0.329	0.359			
Viewing Angle	Hor.	θ _L	40	-	-	Degrees	(1), (5) SR-3	
		θ _R	40	-	-			
	Ver.	φ _H	15	-	-			
		φ _L	30	-	-			
Color Gamut			-	60	-	%		
13 Points White Variation	δ _L		-	-	1.7	-	(6)	

Note 1) Definition of Viewing Angle : Viewing angle range($10 \leq C/R$)

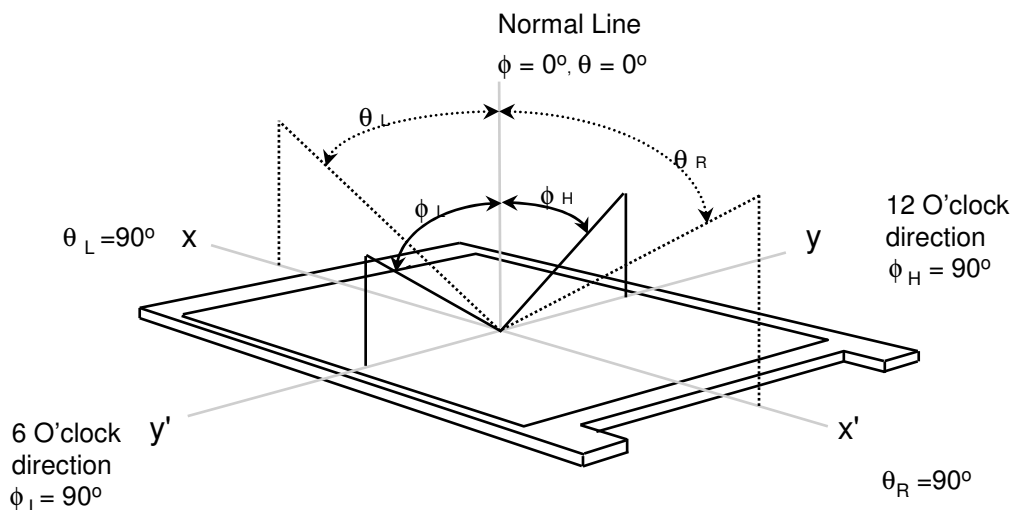

Note 2) Definition of Contrast Ratio (CR) : Ratio of gray max (Gmax) ,gray min (Gmin) at 5 points (33, 55, 77, 37, 73)

$$CR = \frac{CR(33) + CR(55) + CR(77) + CR(37) + CR(73)}{5}$$

Points : 33, 55, 77, 37, 73 at the figure of Note (6).

Note 3) Definition of Response time :

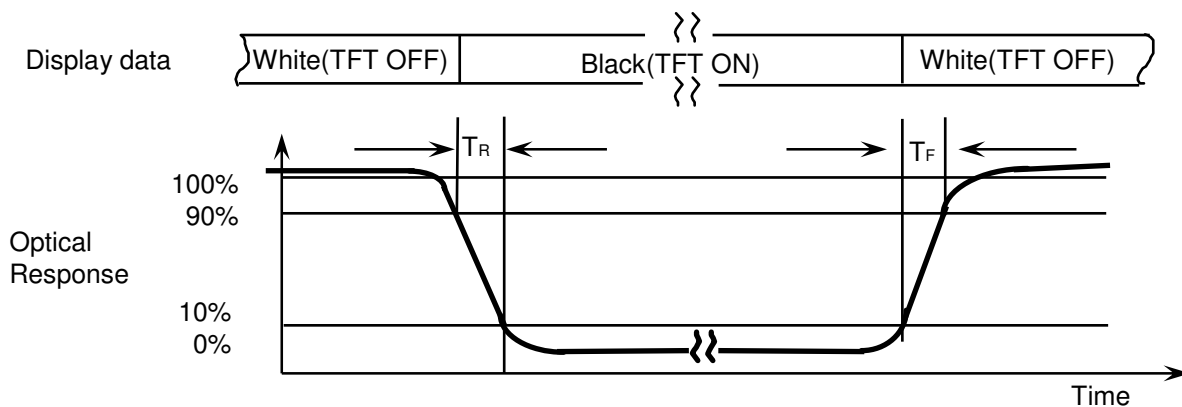

Note 4) Definition of Average Luminance of White : measure the luminance of white at 5 points.

Average Luminance of White ($Y_{L,AVE}$)

$$Y_{L,AVE} = \frac{Y_{L33} + Y_{L55} + Y_{L77} + Y_{L37} + Y_{L73}}{5}$$

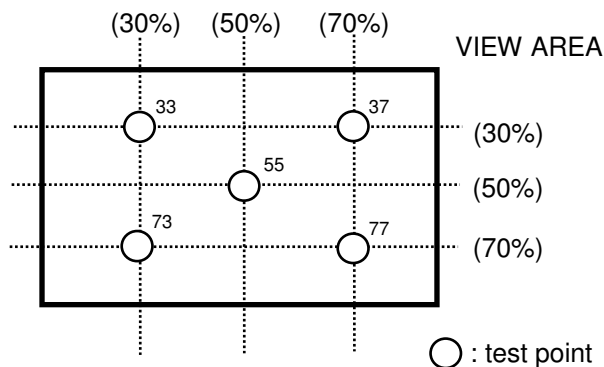

Note 5) After stabilizing and leaving the panel alone at a given temperature for 30 min , the measurement should be executed. Measurement should be executed in a stable, windless, and dark room. 30 min after lighting the backlight. This should be measured in the center of screen.
 LED current : 20 mA
 Environment condition : $T_a = 25 \pm 2 \text{ C}$

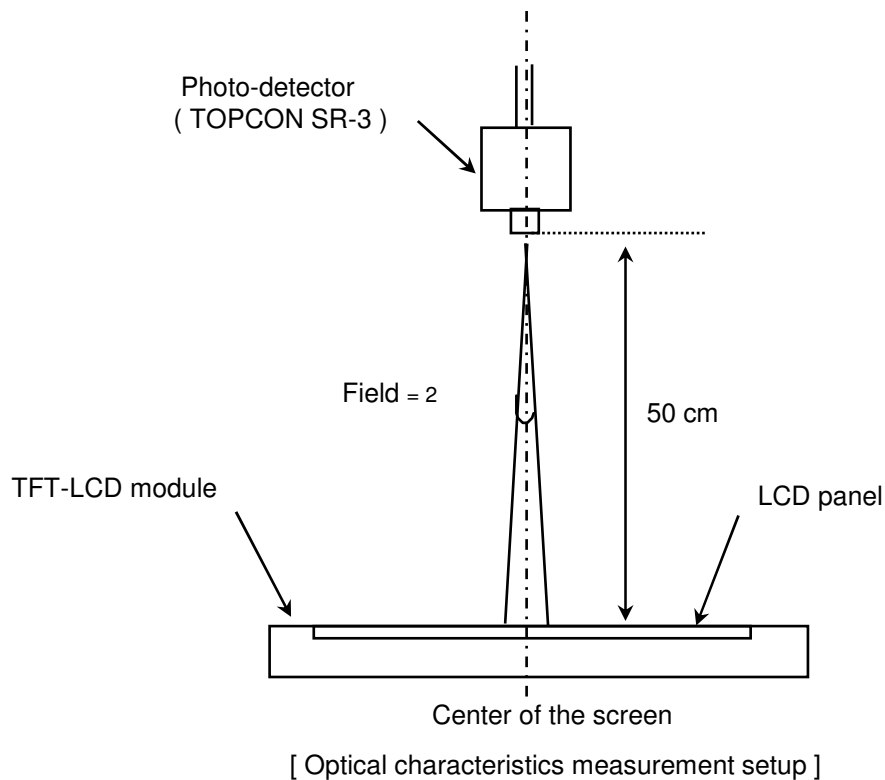

Note 6) Definition of 13 points white variation (δL), [11 ~ 99]

$$\delta L = \frac{\text{Maximum luminance of 13 points}}{\text{Minimum luminance of 13 points}}$$

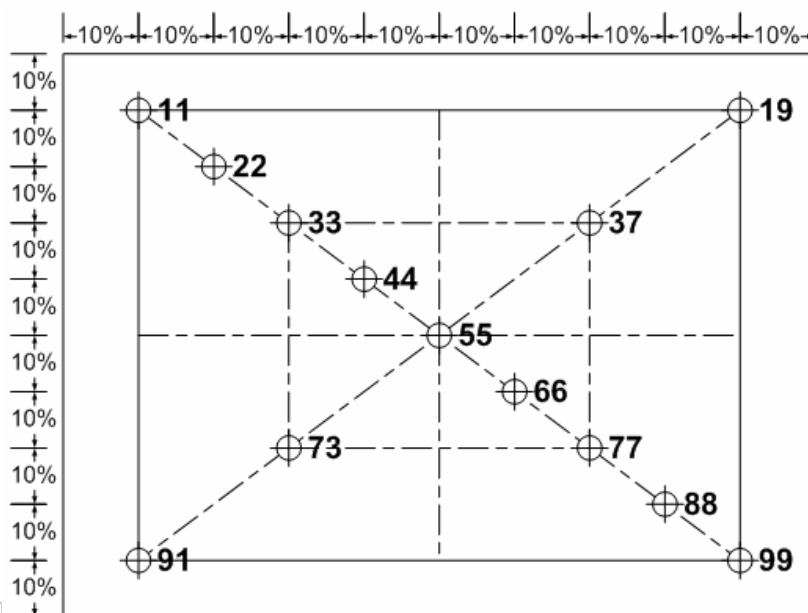

○ : test point

3. ELECTRICAL CHARACTERISTICS

Approval

3.1 TFT LCD MODULE

Ta= 25 ± 2 C

Item	Symbol	Min.	Typ.	Max.	Unit	Note	
Voltage of Power Supply	V _{DD}	3.0	3.3	3.6	V		
Differential Input Voltage for LVDS Receiver Threshold	High	V _{IH}	-	-	+100	mV	V _{CM} = +1.2V
	Low	V _{IL}	-100	-	-	mV	
Vsync Frequency	f _v	-	60	-	Hz		
Hsync Frequency	f _H	-	47.40	-	KHz		
Main Frequency	f _{DCLK}	-	72.33	-	MHz		
Rush Current	I _{RUSH}	-	-	1.5	A	(4)	
Current of Power Supply	White	I _{DD}	-	360	-	mA	(2),(3)*a
	Mosaic		-	420	-	mA	(2),(3)*b
	V. Stripe		-	530	600	mA	(2),(3)*c

Note (1) Display data pins and timing signal pins should be connected.(GND = 0V)

(2) f_v = 60Hz, f_{DCLK} = 72.33 MHz, V_{DD} = 3.3V , DC Current.

(3) Power dissipation pattern

*a) White Pattern

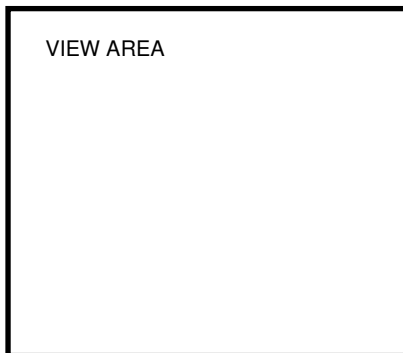

*b) Mosaic Pattern

Display Brightest Gray Level →

Display Darkest Gray Level →

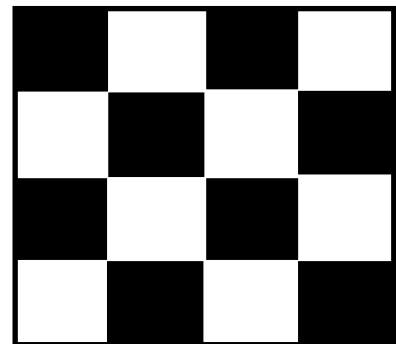

*c) 1dot Vertical stripe pattern

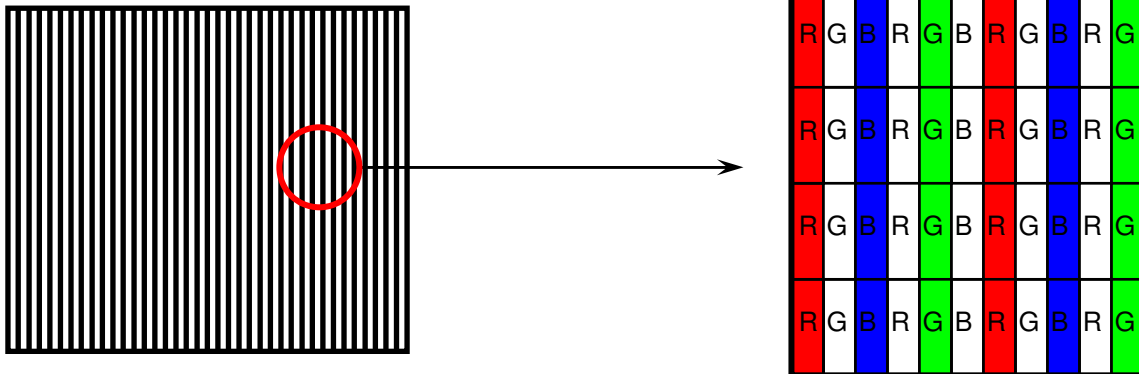

4) Rush current measurement condition

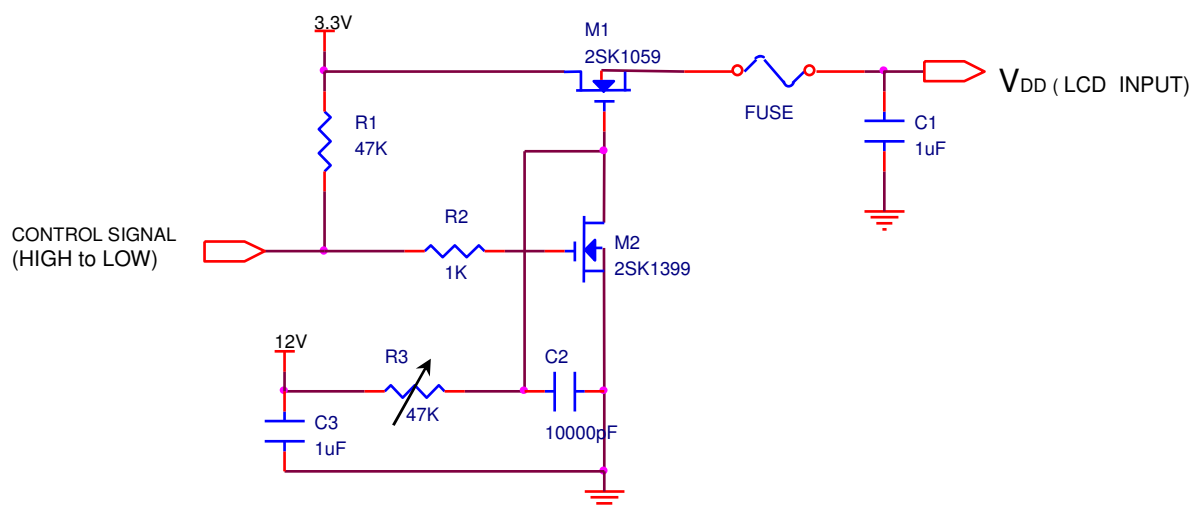

V_{DD} rising time is 470us

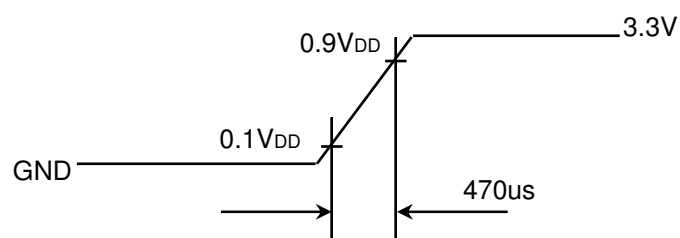

3.2 BACK-LIGHT UNIT

Ta= 25 ± 2 C

Item	Symbol	Min.	Typ.	Max.	Unit	Note
LED Forward Current	IF	-	20	-	mA	
LED Forward Voltage	VF	3.0	-	3.4	V	
LED Array Voltage	VP	24	-	27.2	V	VF X 8 LEDs
Power Consumption	P	2.88	-	3.26	W	IF X VF X 48 LEDs (w/o Converter)

3.3 LED Driver

- LED Driver Manufacturer : ST Micro

Ta= 25 ± 2 C

Item	Symbol	Min.	Typ.	Max.	Unit	Note
Input Voltage	V _{in}	4.7	-	28	V	
Input Current	I	-	2A RMS 5A Peak	-	mA	Max.MOSFET curent in PM6600
Input Power	P _{in}	-	-	-	W	
Operating Frequency	F _o	200KHz	660KHz	1MHz	MHz	600KHz Possible
Output PWM Frequency	F _{PWM}	-	-	-	kHz	No output PWM
Burst Ratio	D	1	-	100	%	PWM freq : 200Hz~20KHz
External PWM Dimming Control Frequency (BLIM)	F _{BLIM}	200Hz	-	20KHz	kHz	V _{in} =8~21V, BLIM=PWM 0V~3.3V
Output Power	P _{out}	-	-	2.3	W	BLIM=100%
Efficiency	η	88	-	94	%	(Generally, Efficiency can be defined depends on Duty cycle , V _{in} and Dimming Freq.)

Note - Test Equipment : Fluke 45

4. BLOCK DIAGRAM

4.1 TFT LCD Module

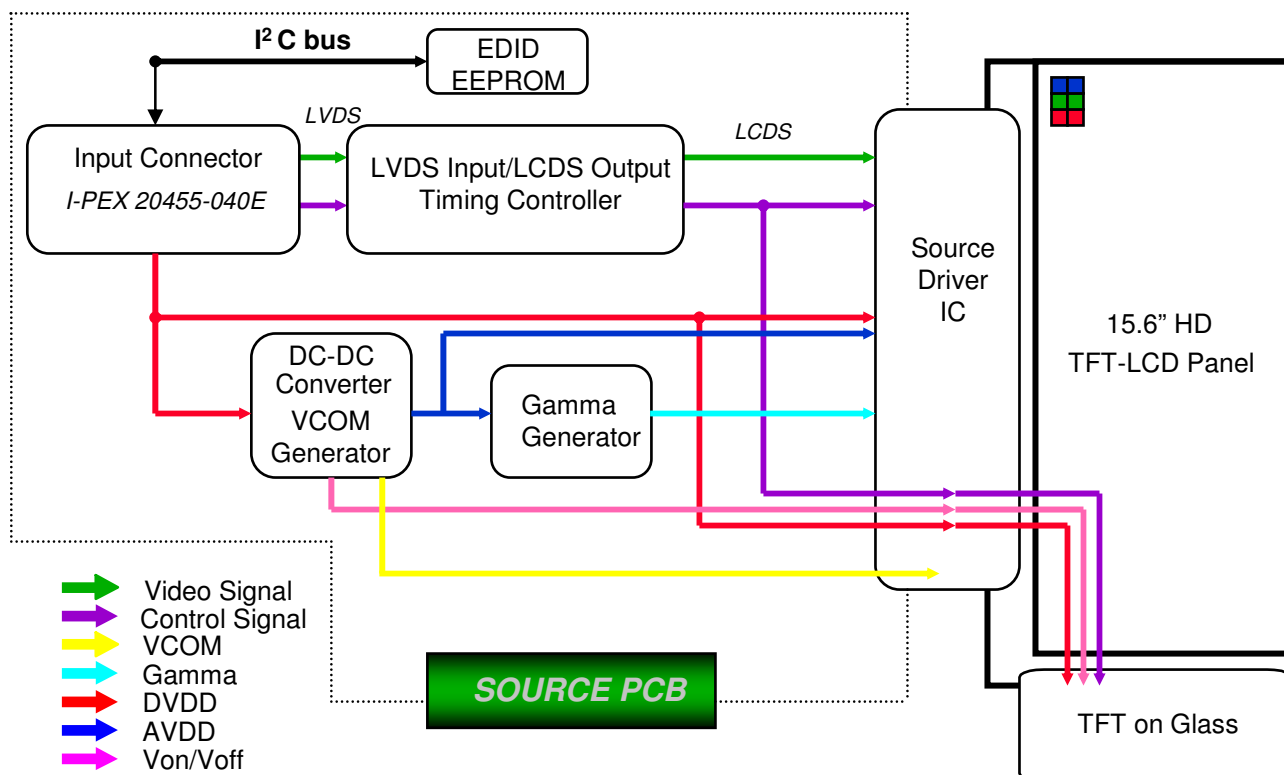

4.2 LED connection and placement

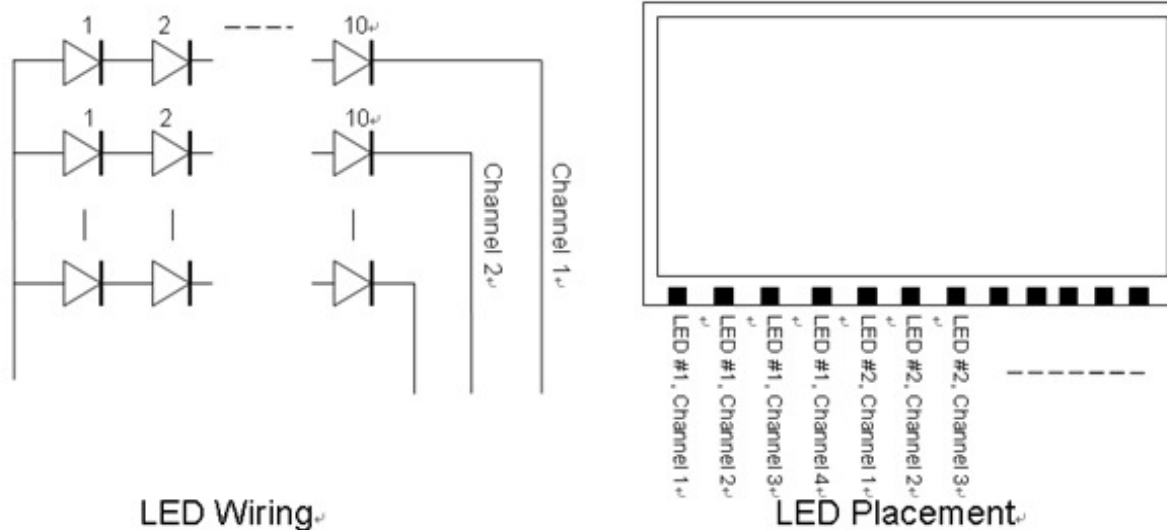

5. INPUT TERMINAL PIN ASSIGNMENT

5.1. Input Signal & Power (LVDS, Connector : I-PEX 20455-040E)

PIN #	Symbol	Description
1	DIAG_LOOP	Diag pin for Dell testing. Pin 1 & 34 must be connected
2	VDD	Power Supply, 3.3 V (typical)
3	VDD	Power Supply, 3.3 V (typical)
4	V EEDID	DDC 3.3V power
5	TEST	Panel Self Test
6	Clk EEDID	DDC Clock
7	DATA EEDID	DDC Data
8	Odd_Rin0-	- LVDS differential data input (R0-R5, G0) (odd pixels)
9	Odd_Rin0+	+ LVDS differential data input (R0-R5, G0) (odd pixels)
10	VSS	Ground – Shield
11	Odd_Rin1-	- LVDS differential data input (G1-G5, B0-B1) (odd pixels)
12	Odd_Rin1+	+ LVDS differential data input (G1-G5, B0-B1) (odd pixels)
13	VSS	Ground – Shield
14	Odd_Rin2-	- LVDS differential data input (B2-B5, HS, VS, DE) (odd pixels)
15	Odd_Rin2+	+ LVDS differential data input (B2-B5, HS, VS, DE) (odd pixels)
16	VSS	Ground – Shield
17	Odd_ClkIN-	- LVDS differential clock input (odd pixels)
18	Odd_ClkIN+	+ LVDS differential clock input (odd pixels)
19	NC	No connection
20	NC	No connection
21	NC	No connection
22	NC	No connection
23	NC	No connection
24	NC	No connection
25	NC	No connection

5. INPUT TERMINAL PIN ASSIGNMENT

5.1. Input Signal & Power (LVDS, Connector : I-PEX 20455-040E)

PIN #	Symbol	Description
26	NC	No connection
27	NC	No connection
28	NC	No connection
29	NC	No connection
30	NC	No connection
31	VSSLED	Ground – LED
32	VSSLED	Ground – LED
33	VSSLED	Ground – LED
34	DIAG_LOOP	Diag pin for Dell testing. Pin 1 & 34 must be connected
35	PWM	System PWM Signal Input (+3.3V Swing)
36	LED_EN	LED enable pin (+3.3V Input)
37	NC	NC
38	VDDLED	7.5V – 21V LED power
39	VDDLED	7.5V – 21V LED power
40	VDDLED	7.5V – 21V LED power

5.2 LVDS Interface : Transmitter DS90CF363 or Compatible

Pin No.	Name	RGB Signal	Pin No.	Name	RGB Signal
51	TxIN0	R0	14	TxIN14	G5
52	TxIN1	R1	15	TxIN15	B0
54	TxIN2	R2	19	TxIN18	B1
55	TxIN3	R3	20	TxIN19	B2
56	TxIN4	R4	22	TxIN20	B3
3	TxIN6	R5	23	TxIN21	B4
4	TxIN7	G0	24	TxIN22	B5
6	TxIN8	G1	27	TxIN24	Hsync
7	TxIN9	G2	28	TxIN25	Vsync
11	TxIN12	G3	30	TxIN26	DE
12	TxIN13	G4	31	TxCLKIN	Clock

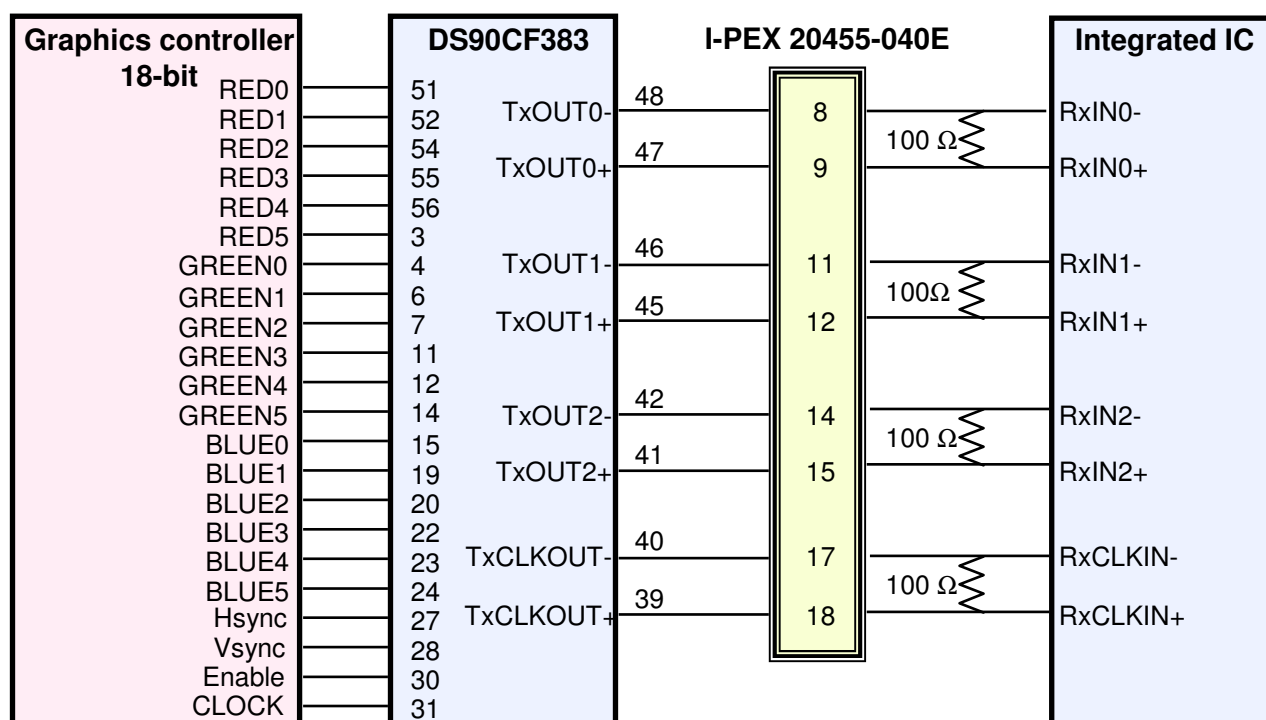
LVDS INTERFACE

Note : The LCD Module uses a 100ohm resistor between positive and negative lines of each receiver input.

5.3 Timing Diagrams of LVDS For Transmission

LVDS Receiver : Integrated T-CON

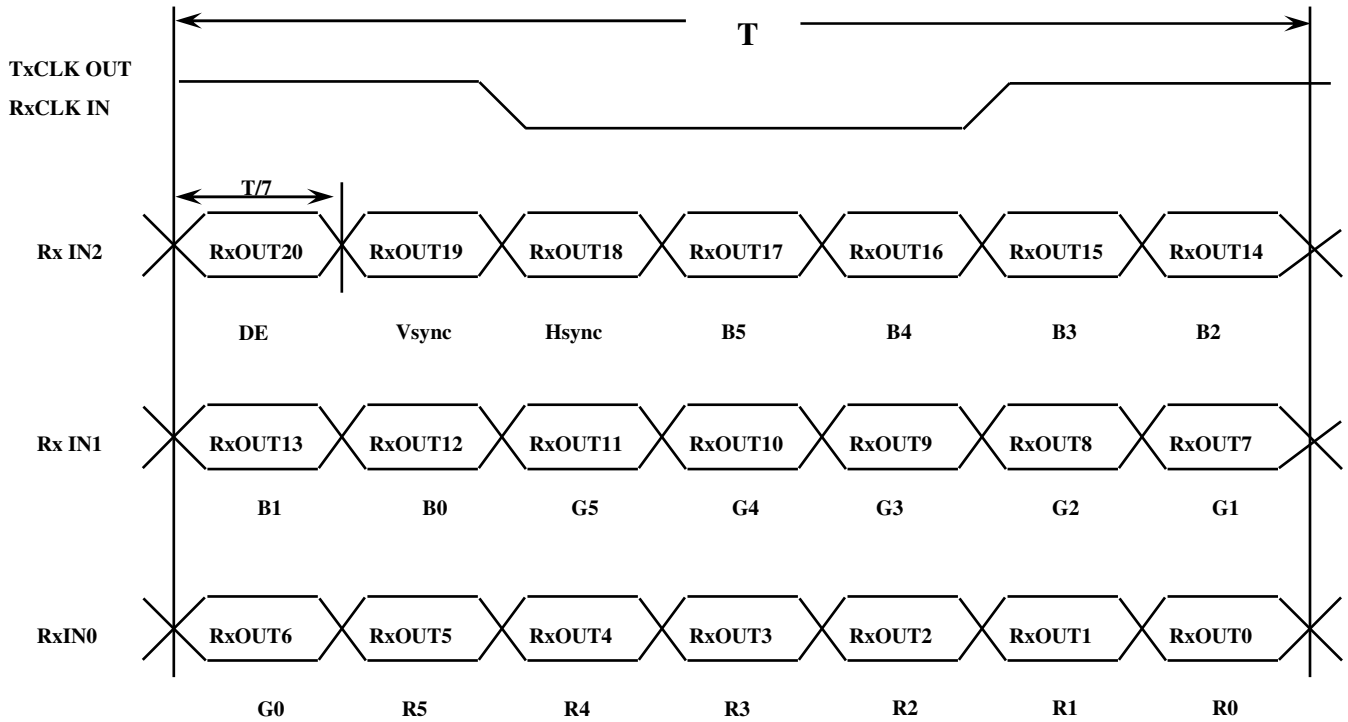

5.4 Input Signals, Basic Display Colors and Gray Scale of Each Color

Color	Display	Data Signal																	Gray Scale Level
		Red					Green					Blue							
		R0	R1	R2	R3	R4	R5	G0	G1	G2	G3	G4	G5	B0	B1	B2	B3	B4	
Basic Colors	Black	0	0	0	0	0	0	0	0	0	0	0	0	0	0	0	0	0	-
	Blue	0	0	0	0	0	0	0	0	0	0	0	0	1	1	1	1	1	-
	Green	0	0	0	0	0	0	1	1	1	1	1	1	0	0	0	0	0	-
	Cyan	0	0	0	0	0	0	1	1	1	1	1	1	1	1	1	1	1	-
	Red	1	1	1	1	1	1	0	0	0	0	0	0	0	0	0	0	0	-
	Magenta	1	1	1	1	1	1	0	0	0	0	0	0	1	1	1	1	1	-
	Yellow	1	1	1	1	1	1	1	1	1	1	1	1	0	0	0	0	0	-
	White	1	1	1	1	1	1	1	1	1	1	1	1	1	1	1	1	1	-
Gray Scale Of Red	Black	0	0	0	0	0	0	0	0	0	0	0	0	0	0	0	0	0	R0
	Dark	1	0	0	0	0	0	0	0	0	0	0	0	0	0	0	0	0	R1
	↑	0	1	0	0	0	0	0	0	0	0	0	0	0	0	0	0	0	R2
	:	:	:	:	:	:	:	:	:	:	:	:	:	:	:	:	:	:	R3~R60
	:	:	:	:	:	:	:	:	:	:	:	:	:	:	:	:	:	:	
	↓	1	0	1	1	1	1	0	0	0	0	0	0	0	0	0	0	0	R61
	Light	0	1	1	1	1	1	0	0	0	0	0	0	0	0	0	0	0	R62
	Red	1	1	1	1	1	1	0	0	0	0	0	0	0	0	0	0	0	R63
Gray Scale Of Green	Black	0	0	0	0	0	0	0	0	0	0	0	0	0	0	0	0	0	G0
	Dark	0	0	0	0	0	0	1	0	0	0	0	0	0	0	0	0	0	G1
	↑	0	0	0	0	0	0	0	1	0	0	0	0	0	0	0	0	0	G2
	:	:	:	:	:	:	:	:	:	:	:	:	:	:	:	:	:	:	G3~G60
	:	:	:	:	:	:	:	:	:	:	:	:	:	:	:	:	:	:	
	↓	0	0	0	0	0	0	1	0	1	1	1	1	0	0	0	0	0	G61
	Light	0	0	0	0	0	0	0	1	1	1	1	1	0	0	0	0	0	G62
	Green	0	0	0	0	0	0	1	1	1	1	1	1	0	0	0	0	0	G63
Gray Scale Of Blue	Black	0	0	0	0	0	0	0	0	0	0	0	0	0	0	0	0	0	B0
	Dark	0	0	0	0	0	0	0	0	0	0	0	0	1	0	0	0	0	B1
	↑	0	0	0	0	0	0	0	0	0	0	0	0	0	1	0	0	0	B2
	:	:	:	:	:	:	:	:	:	:	:	:	:	:	:	:	:	:	B3~B60
	:	:	:	:	:	:	:	:	:	:	:	:	:	:	:	:	:	:	
	↓	0	0	0	0	0	0	0	0	0	0	0	0	1	0	1	1	1	B61
	Light	0	0	0	0	0	0	0	0	0	0	0	0	0	1	1	1	1	B62
	Blue	0	0	0	0	0	0	0	0	0	0	0	0	1	1	1	1	1	B63

Note 1) Definition of gray :

Rn: Red gray, Gn: Green gray, Bn: Blue gray (n=gray level)

Note 2) Input signal: 0 =Low level voltage, 1=High level voltage

5.5 Pixel Format in the display

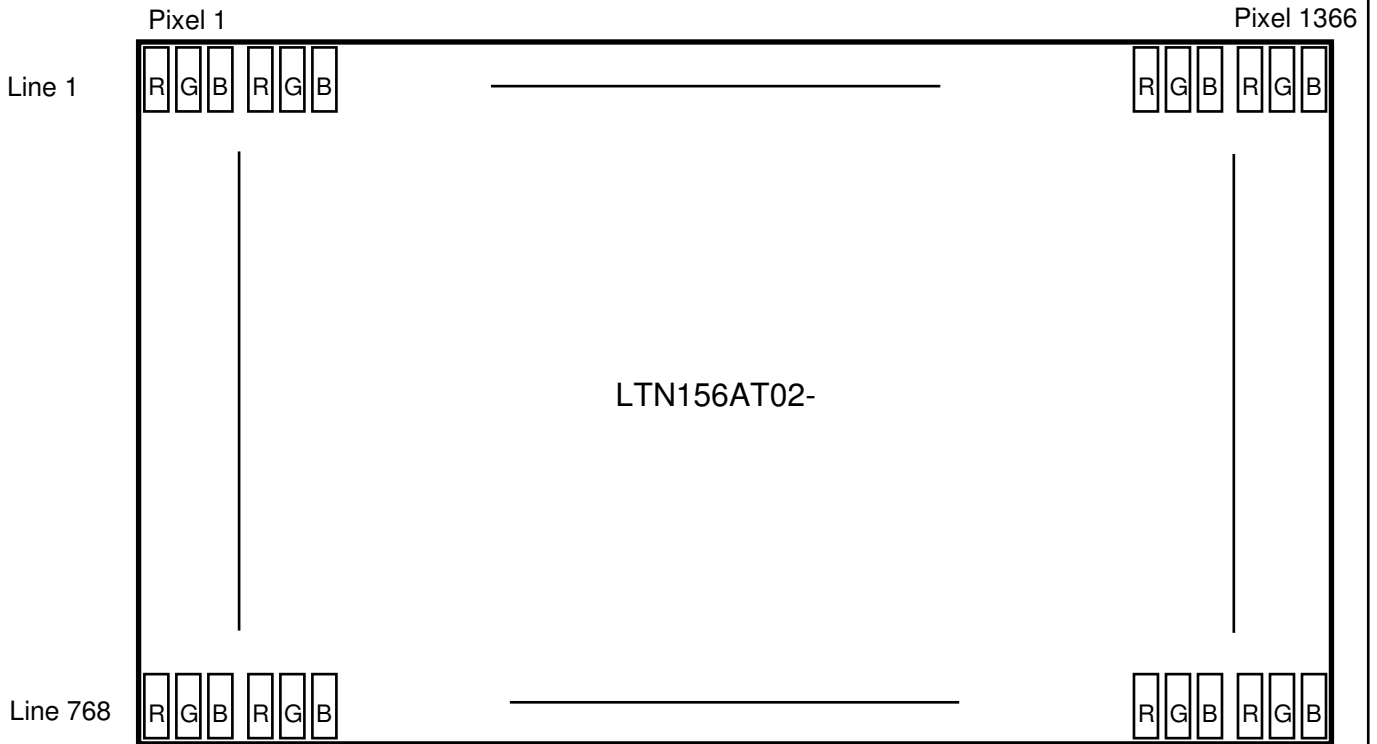

6. INTERFACE TIMING

6.1 Timing Parameters

Signal	Item	Symbol	Min.	Typ.	Max.	Unit	Note
Frame Frequency	Cycle	TV	-	790	-	Lines	-
Vertical Active Display Term	Display Period	TVD	-	768	-	Lines	-
One Line Scanning Time	Cycle	TH	-	1526	-	Clocks	-
Horizontal Active Display Term	Display Period	THD	-	1366	-	Clocks	-

6.2 Timing diagrams of interface signal

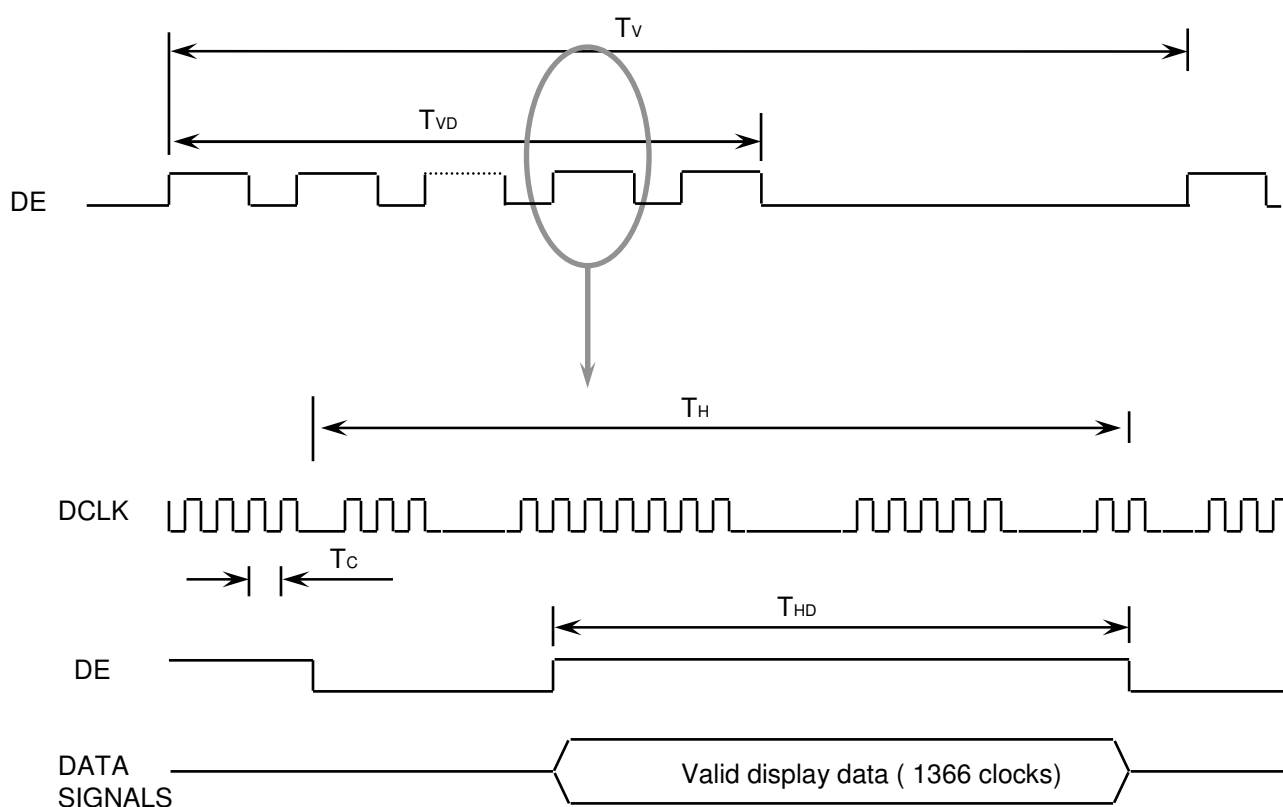

6.3 Power ON/OFF Sequence

Approval

: To prevent a latch-up or DC operation of the LCD module, the power on/off sequence should be as the diagram below.

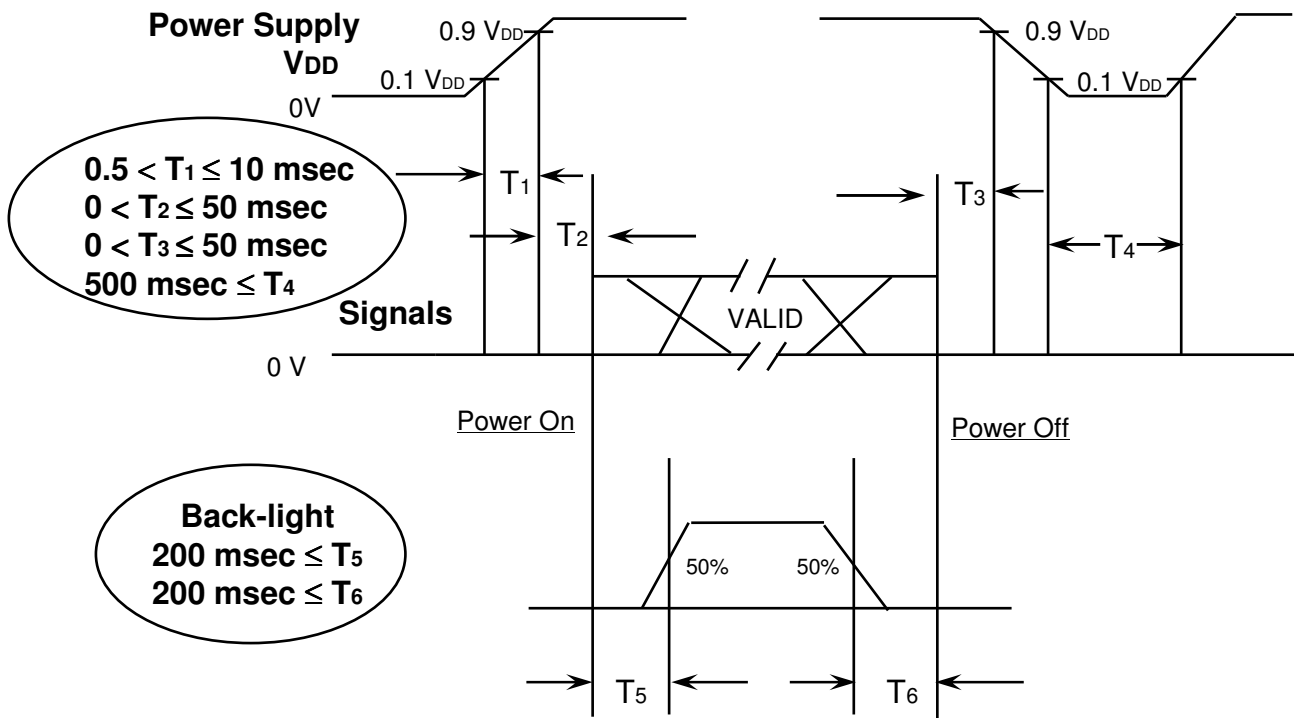

Power ON/OFF Sequence

- T1 : Vdd rising time from 10% to 90%
- T2 : The time from Vdd to valid data at power ON.
- T3 : The time from valid data off to Vdd off at power Off.
- T4 : Vdd off time for Windows restart
- T5 : The time from valid data to B/L enable at power ON.
- T6 : The time from valid data off to B/L disable at power Off.

NOTE.

- (1) The supply voltage of the external system for the module input should be the same as the definition of VDD.
- (2) Apply the lamp voltage within the LCD operation range. When the back-light turns on before the LCD operation or the LCD turns off before the back-light turns off, the display may momentarily become white.
- (3) In case of VDD = off level, please keep the level of input signals on the low or keep a high impedance.
- (4) T4 should be measured after the module has been fully discharged between power off and on period.
- (5) Interface signal shall not be kept at high impedance when the power is on.

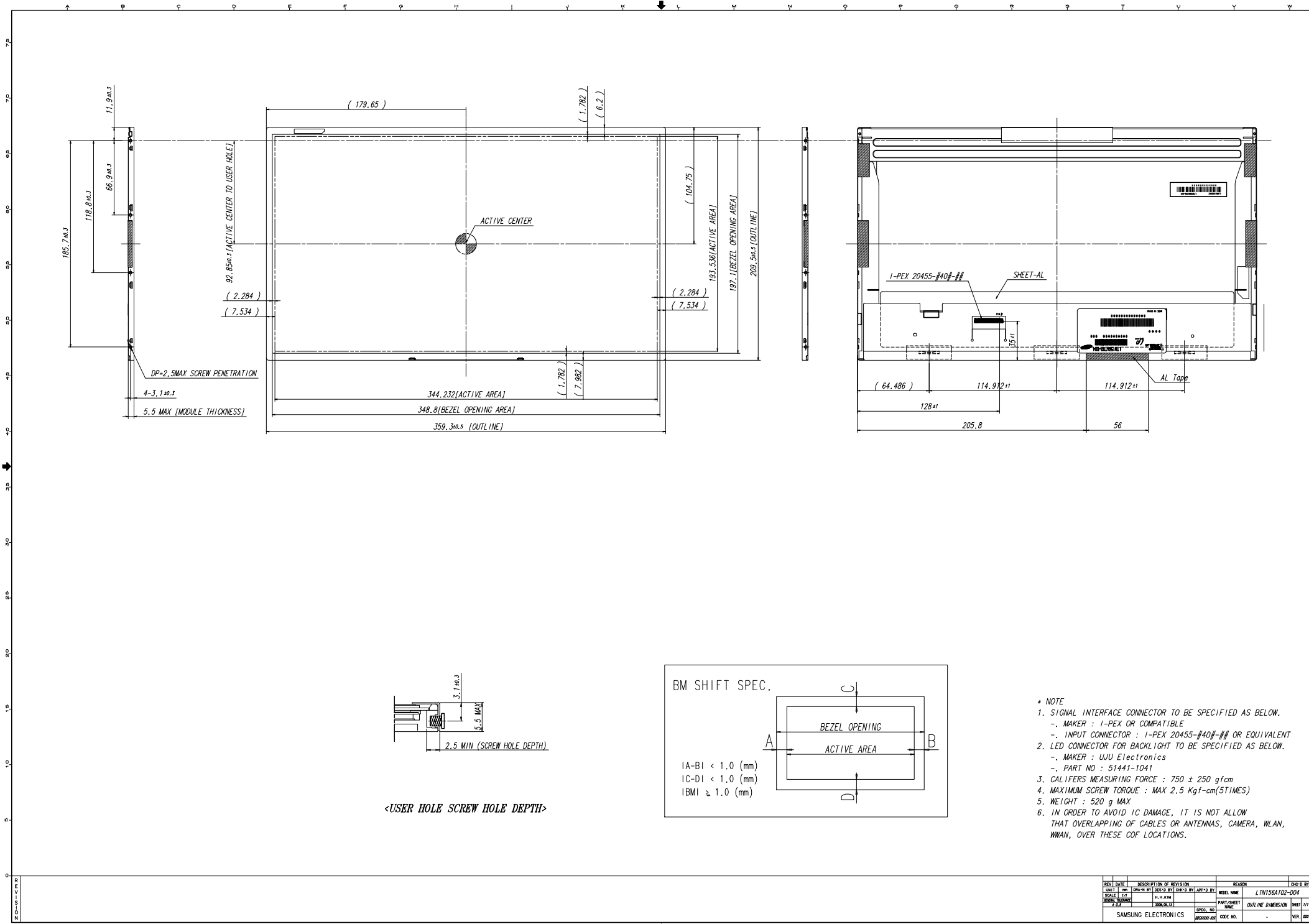

- * NOTE
- SIGNAL INTERFACE CONNECTOR TO BE SPECIFIED AS BELOW.
 - MAKER : 1-PEX OR COMPATIBLE
 - INPUT CONNECTOR : 1-PEX 20455-#40#-## OR EQUIVALENT
 - LED CONNECTOR FOR BACKLIGHT TO BE SPECIFIED AS BELOW.
 - MAKER : UJU Electronics
 - PART NO : 51441-1041
 - CALIFERS MEASURING FORCE : 750 ± 250 gf/cm
 - MAXIMUM SCREW TORQUE : MAX 2.5 Kgf-cm(5TIMES)
 - WEIGHT : 520 g MAX
 - IN ORDER TO AVOID IC DAMAGE, IT IS NOT ALLOW THAT OVERLAPPING OF CABLES OR ANTENNAS, CAMERA, WLAN, WWAN, OVER THESE COF LOCATIONS.

REV	DATE	DESCRIPTION OF REVISION	REASON	CHK'D BY
001	11/17	INITIAL DESIGN		
002	11/17	SCALE CHANGE		
003	11/17	DESIGN CHANGE		
004	11/17	DESIGN CHANGE		
005	11/17	DESIGN CHANGE		
006	11/17	DESIGN CHANGE		
007	11/17	DESIGN CHANGE		
008	11/17	DESIGN CHANGE		
009	11/17	DESIGN CHANGE		
010	11/17	DESIGN CHANGE		
011	11/17	DESIGN CHANGE		
012	11/17	DESIGN CHANGE		
013	11/17	DESIGN CHANGE		
014	11/17	DESIGN CHANGE		
015	11/17	DESIGN CHANGE		
016	11/17	DESIGN CHANGE		
017	11/17	DESIGN CHANGE		
018	11/17	DESIGN CHANGE		
019	11/17	DESIGN CHANGE		
020	11/17	DESIGN CHANGE		
021	11/17	DESIGN CHANGE		
022	11/17	DESIGN CHANGE		
023	11/17	DESIGN CHANGE		
024	11/17	DESIGN CHANGE		
025	11/17	DESIGN CHANGE		
026	11/17	DESIGN CHANGE		
027	11/17	DESIGN CHANGE		
028	11/17	DESIGN CHANGE		
029	11/17	DESIGN CHANGE		
030	11/17	DESIGN CHANGE		
031	11/17	DESIGN CHANGE		
032	11/17	DESIGN CHANGE		
033	11/17	DESIGN CHANGE		
034	11/17	DESIGN CHANGE		
035	11/17	DESIGN CHANGE		
036	11/17	DESIGN CHANGE		
037	11/17	DESIGN CHANGE		
038	11/17	DESIGN CHANGE		
039	11/17	DESIGN CHANGE		
040	11/17	DESIGN CHANGE		
041	11/17	DESIGN CHANGE		
042	11/17	DESIGN CHANGE		
043	11/17	DESIGN CHANGE		
044	11/17	DESIGN CHANGE		
045	11/17	DESIGN CHANGE		
046	11/17	DESIGN CHANGE		
047	11/17	DESIGN CHANGE		
048	11/17	DESIGN CHANGE		
049	11/17	DESIGN CHANGE		
050	11/17	DESIGN CHANGE		
051	11/17	DESIGN CHANGE		
052	11/17	DESIGN CHANGE		
053	11/17	DESIGN CHANGE		
054	11/17	DESIGN CHANGE		
055	11/17	DESIGN CHANGE		
056	11/17	DESIGN CHANGE		
057	11/17	DESIGN CHANGE		
058	11/17	DESIGN CHANGE		
059	11/17	DESIGN CHANGE		
060	11/17	DESIGN CHANGE		
061	11/17	DESIGN CHANGE		
062	11/17	DESIGN CHANGE		
063	11/17	DESIGN CHANGE		
064	11/17	DESIGN CHANGE		
065	11/17	DESIGN CHANGE		
066	11/17	DESIGN CHANGE		
067	11/17	DESIGN CHANGE		
068	11/17	DESIGN CHANGE		
069	11/17	DESIGN CHANGE		
070	11/17	DESIGN CHANGE		
071	11/17	DESIGN CHANGE		
072	11/17	DESIGN CHANGE		
073	11/17	DESIGN CHANGE		
074	11/17	DESIGN CHANGE		
075	11/17	DESIGN CHANGE		
076	11/17	DESIGN CHANGE		
077	11/17	DESIGN CHANGE		
078	11/17	DESIGN CHANGE		
079	11/17	DESIGN CHANGE		
080	11/17	DESIGN CHANGE		
081	11/17	DESIGN CHANGE		
082	11/17	DESIGN CHANGE		
083	11/17	DESIGN CHANGE		
084	11/17	DESIGN CHANGE		
085	11/17	DESIGN CHANGE		
086	11/17	DESIGN CHANGE		
087	11/17	DESIGN CHANGE		
088	11/17	DESIGN CHANGE		
089	11/17	DESIGN CHANGE		
090	11/17	DESIGN CHANGE		
091	11/17	DESIGN CHANGE		
092	11/17	DESIGN CHANGE		
093	11/17	DESIGN CHANGE		
094	11/17	DESIGN CHANGE		
095	11/17	DESIGN CHANGE		
096	11/17	DESIGN CHANGE		
097	11/17	DESIGN CHANGE		
098	11/17	DESIGN CHANGE		
099	11/17	DESIGN CHANGE		
100	11/17	DESIGN CHANGE		

8. PACKING

1. CARTON(Internal Package)

(1) Packing Form

Corrugated Cardboard box and Corrupad form as shock absorber

(2) Packing Method

CUSHION BOTTOM

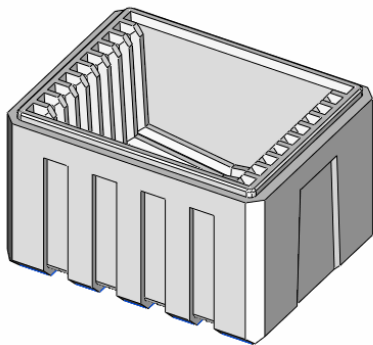

PANEL : 2EA/SLIT

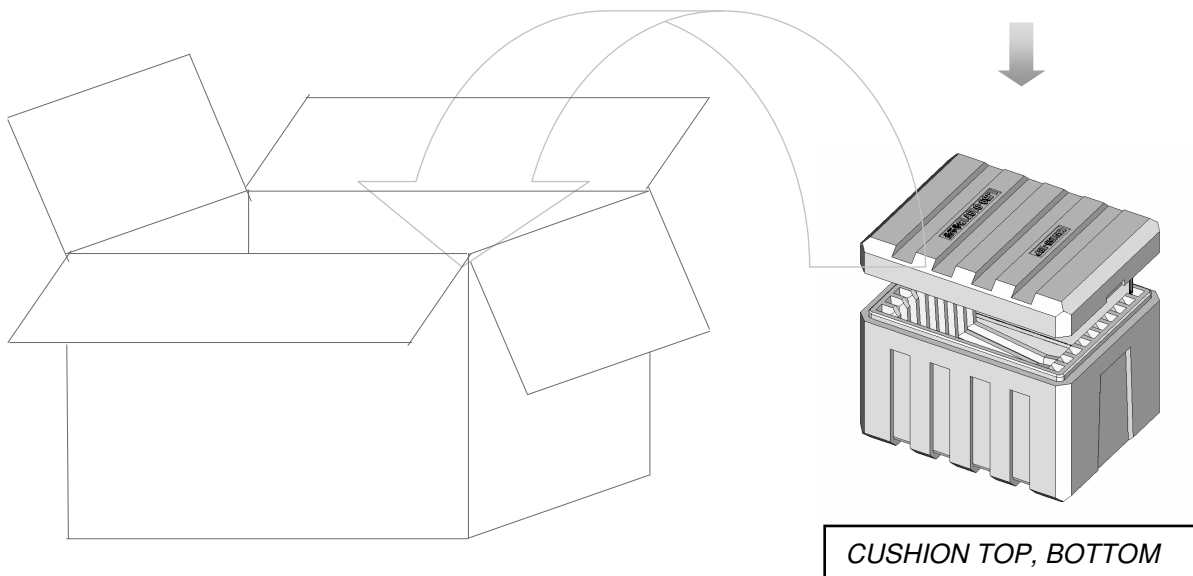
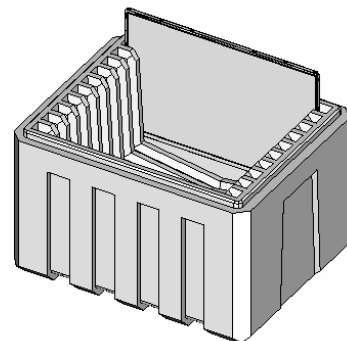

Note (1) Total : Approx. 12400g

(2) Acceptance number of piling : 20 sets

(3) Carton size : 344(W) X 432(D) X 329(H)

No	Part name	Quantity
1	Static electric protective sack	10
2	Packing case (Inner box) included shock absorber	1 set
3	Pictorial marking	2 pcs
4	Carton	1 set

9. MARKINGS & OTHERS

A nameplate bearing followed by is affixed to a shipped product at the specified location on each product.

(1) Parts number : LTNXXXXXXXX-XXX

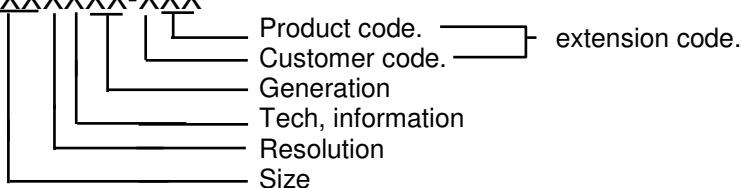

(2) Revision : Three letters

(3) Lot number : X Y 7 A XXX XX X

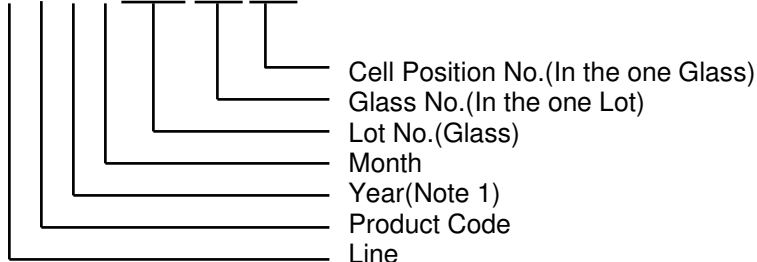

NOTE 1). This code indicating year is omitted in the products of KIHEUNG site.

(5) Nameplate Indication(Following example is only for reference)

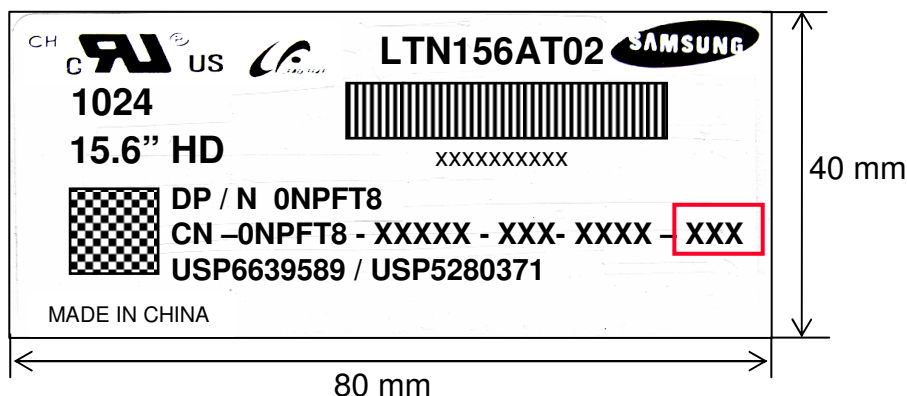

Parts name : LTN156AT02
 Lot number : xxxxxxxxxxxx
 Inspected work week : 1024 Number (2010 year 24st week)
 DP/N : Part No ("0NPFT8" is for LTN156AT02)
 XXX : Product Revision Code

This HIGH VOLTAGE CAUTION is carved in mold frame

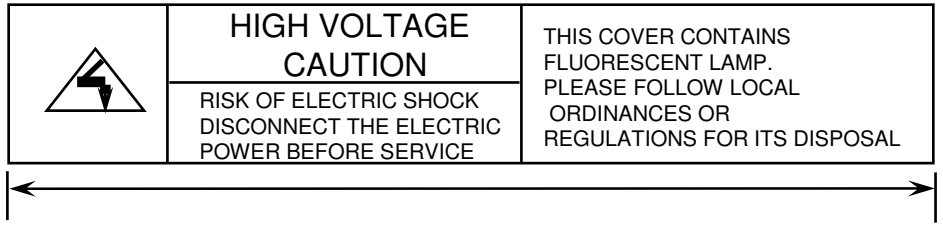

Approval

10mm High voltage caution

70mm

※ Panel revision code scheme (Refer to the Red box on the label)

Build Name(s)	Revision Code(s)
SST (WS)	X00, X01, X02, ... X09
PT (ES)	X10, X11, X12, ... X19
ST (CS)	X20, X21, X23, ... X29
XB (MP)	A00, A01, A02, ... A99

(6) Packing small box attach (Following example is only for reference)

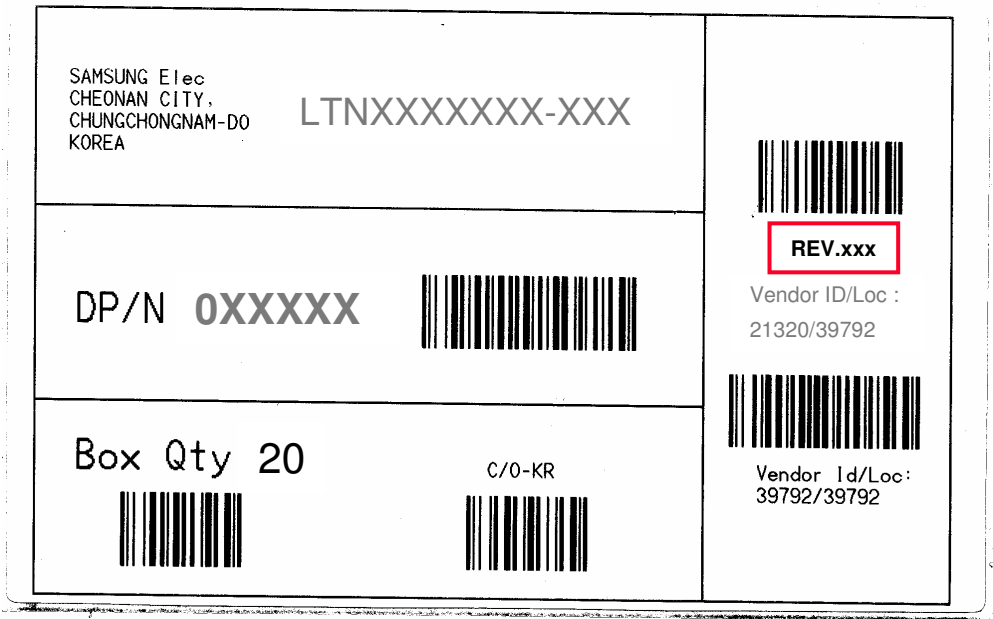

(7) Packing box Marking : Samsung TFT-LCD Brand Name



10. GENERAL PRECAUTIONS

Approval

1. Handling

- (a) When the module is assembled, It should be attached to the system firmly using every mounting holes. Be careful not to twist and bend the modules.
- (b) Refrain from strong mechanical shock and / or any force to the module. In addition to damage, this may cause improper operation or damage to the module.
- (c) Note that polarizers are very fragile and could be easily damaged. Do not press or scratch the surface harder than a HB pencil lead.
- (d) Wipe off water droplets or oil immediately. If you leave the droplets for a long time, Staining and discoloration may occur.
- (e) If the surface of the polarizer is dirty, clean it using some absorbent cotton or soft cloth.
- (f) The desirable cleaners are water, IPA (Isopropyl Alcohol) or Hexane. Do not use Ketone type materials(ex. Acetone), Ethyl alcohol, Toluene, Ethyl acid or Methyl chloride. It might permanent damage to the polarizer due to chemical reaction.
- (g) If the liquid crystal material leaks from the panel, it should be kept away from the eyes or mouth. In case of contact with hands, legs or clothes, it must be washed away thoroughly with soap.
- (h) Protect the module from static, it may cause damage to the C-MOS Gate Array IC.
- (i) Use fingerstalls with soft gloves in order to keep display clean during the incoming inspection and assembly process.
- (j) Do not disassemble the module.
- (k) Do not pull or fold the lamp wire.
- (l) Do not adjust the variable resistor which is located on the back side.
- (m) Protection film for polarizer on the module shall be slowly peeled off just before use so that the electrostatic charge can be minimized.
- (n) Pins of I/F connector shall not be touched directly with bare hands.

2. STORAGE

- (a) Do not leave the module in high temperature, and high humidity for a long time. It is highly recommended to store the module with temperature from 0 to 35 °C and relative humidity of less than 70%.
- (b) Do not store the TFT-LCD module in direct sunlight.
- (c) The module shall be stored in a dark place. It is prohibited to apply sunlight or fluorescent light during the store.

3. OPERATION

- (a) Do not connect, disconnect the module in the “ Power On” condition.
- (b) Power supply should always be turned on/off by following item 6.3 “ Power on/off sequence “.
- (c) Module has high frequency circuits. Sufficient suppression to the electromagnetic interference shall be done by system manufacturers. Grounding and shielding methods may be important to minimize the interference.
- (d) The standard limited warranty is only applicable when the module is used for general notebook applications. If used for purposes other than as specified, SEC is not to be held reliable for the defective operations. It is strongly recommended to contact SEC to find out fitness for a particular purpose.

4. OTHERS

- (a) Ultra-violet ray filter is necessary for outdoor operation.
- (b) Avoid condensation of water. It may result in improper operation or disconnection of electrode.
- (c) Do not exceed the absolute maximum rating value. (the supply voltage variation, input voltage variation, variation in part contents and environmental temperature, so on) Otherwise the module may be damaged.
- (d) If the module displays the same pattern continuously for a long period of time, it can be the situation when the image “sticks” to the screen.
- (e) This module has its circuitry PCB's on the rear side and should be handled carefully in order not to be stressed.