

mass integrated

global part distribution • product lifecycle partner
excess inventory management • value-ad service provider



Data sheet provided by Mass Integrated

massintegrated.com • displayalliance.com

Please call +1.978.465.6190
Email: sales@massintegrated.com



ISO 9001: 2008

Mass Integrated complies with all DMCA takedown notices. Please send a formal DMCA Takedown Notice to Mass Integrated Systems, Inc. • 18 Henry Graf Jr. Road, Unit 1 • Newburyport, MA 01950.



ELECTRONICS

Approval



TO :
DATE : Mar. 24, 2010.

SAMSUNG TFT-LCD
MODEL NO. : LTN160AT06-B/W01

NOTE : Extension code [-B/W01]
 → LTN160AT06
 Surface type [**Glare**]

The information described in this SPEC is preliminary and can be changed without prior notice

APPROVED BY : *Sanleey Seonun*

PREPARED BY : **Thomas Oh**

Samsung Electronics Co., Ltd.



CONTENTS

Revision History	----- (3)
General Description	----- (4)
1. Absolute Maximum Ratings	----- (5)
1.1 Absolute Ratings of environment	
1.2 Electrical Absolute Ratings	
2. Optical Characteristics	----- (7)
3. Electrical Characteristics	----- (10)
3.1 TFT LCD Module	
3.2 Backlight Unit	
3.3 Inverter	
4. Block Diagram	----- (13)
4.1 TFT LCD Module	
4.2 Backlight Unit	
4.3 Inverter Unit	
5. Input Terminal Pin Assignment	----- (14)
5.1 Input Signal & Power	
5.2 LVDS Interface	
5.3 Timing Diagrams of LVDS For Transmitting	
5.4 Input Signals, Basic Display Colors and Gray Scale of Each Color.	
5.5 Pixel format	
6. Interface Timing	----- (20)
6.1 Timing Parameters	
6.2 Timing Diagrams of interface Signal	
6.3 Power ON/OFF Sequence	
7. Outline Dimension	----- (23)
8. Packing	----- (25)
9. Marking & Others	----- (25)
10. General Precaution	----- (28)
11. EDID	----- (30)

REVISION HISTORY

Approval

Date	Revision No.	Page	Summary
Mar. 24. 2010	A00	All	The approval specification was issued first.

GENERAL DESCRIPTION

DESCRIPTION

LTN160AT06-A01 is a color active matrix TFT (Thin Film Transistor) liquid crystal display (LCD) that uses amorphous silicon TFT as switching devices. This model is composed of a TFT LCD panel, a driver circuit and a backlight unit. The resolution of a 16.0" contains 1366 x 768 pixels and can display up to 262,144 colors. 6 O'clock direction is the optimum viewing angle.

FEATURES

- High contrast ratio, high aperture structure
- 1366 x 768 pixels resolution (16:9)
- Color Gamut (Typical 60%)
- Low power consumption
- Fast Response Time
- DE(Data enable) only mode
- 3.3V LVDS Interface
- Onboard EEDID chip
- RoHS Compliance
- LED converter embedded

APPLICATIONS

- Notebook PC
- If the usage of this product is not for PC application, but for others, please contact SEC

GENERAL INFORMATION

Item	Specification	Unit	Note
Display area	353.45 (H) x 198.72(V) (16.0" diagonal)	mm	
Driver element	a-Si TFT active matrix		
Display colors	262,144		
Number of pixel	1366 x 768	pixel	16 : 9
Pixel arrangement	RGB vertical stripe		
Pixel pitch	0.25875 (H) x 0.25875 (V) (TYP.)	mm	
Display Mode	Normally white		
Surface treatment	Haze 0, Hardness 3H		

Mechanical Information

Item		Min.	Typ.	Max.	Unit	Note
Module size	Horizontal (H)	364.5	365.0	365.5	mm	
	Vertical (V)	213.5	214.0	214.5	mm	
	Depth (D)	-	-	5.8	mm	(1)
Weight		-	-	480	g	

Note (1) Measurement condition of outline dimension

- . Equipment : Vernier Calipers
- . Push Force : 500g · f (minimum)

1. ABSOLUTE MAXIMUM RATINGS

1.1 ENVIRONMENTAL ABSOLUTE RATINGS

Item	Symbol	Min.	Max.	Unit	Note
Storage temperate	TSTG	-20	60	C	(1),(5)
Operating temperate (Temperature of glass surface)	TOPR	0	50	C	(1),(5)
Shock (non-operating)	Snop	-	240	G	(2),(4)
Vibration (non-operating)	Vnop	-	2.41	G	(3),(4)

Note (1) Temperature and relative humidity range are shown in the figure below.

95 % RH Max. ($40\text{ }^{\circ}\text{C} \geq T_a$)

Maximum wet - bulb temperature at $39\text{ }^{\circ}\text{C}$ or less. ($T_a > 40\text{ }^{\circ}\text{C}$) No condensation

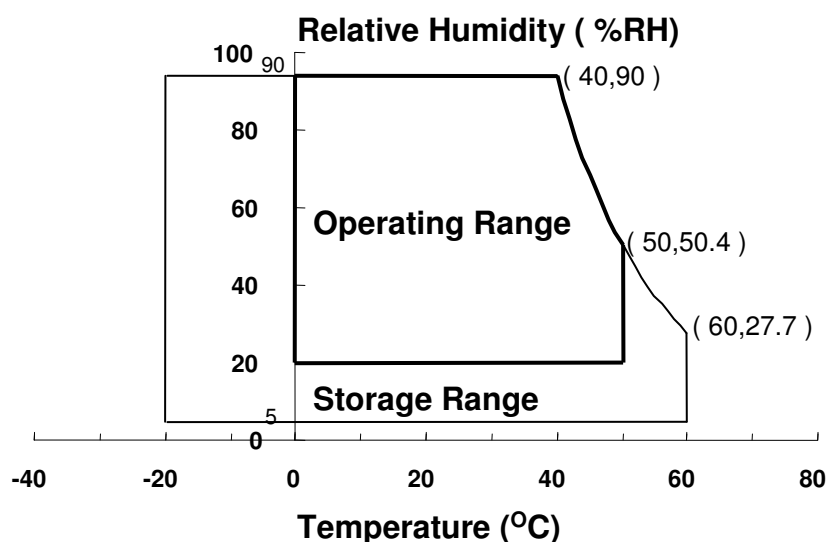

(2) 2ms, half sine wave, one time for $\pm X, \pm Y, \pm Z$.

(3) 5 - 500 Hz, random vibration, 30min for X, Y, Z.

(4) At testing Vibration and Shock, the fixture in holding the Module to be tested have to be hard and rigid enough so that the Module would not be twisted or bent by the fixture.

(5) If product is used for extended time excessively or exposed to high temperatures for extended time, there is a possibility of wide viewing angle film damage which could affect visual characteristics.

1.2 ELECTRICAL ABSOLUTE RATINGS

(1) TFT LCD MODULE

 $V_{DD} = 3.3V$, $V_{SS} = GND = 0V$

Item	Symbol	Min.	Max.	Unit	Note
Power Supply Voltage	V_{DD}	$V_{DD} - 0.3$	$V_{DD} + 0.3$	V	(1)
Logic Input Voltage	V_{IN}	$V_{DD} - 0.3$	$V_{DD} + 0.3$	V	(1)

Note (1) Within T_a (25 ± 2 C)

(2) BACK-LIGHT UNIT

Item	Symbol	Min.	Typ.	Max.	Unit	Note
LED Current	I_L	-	20	-	mA	(1)
LED Voltage	V_L	-	3.2	-	V	(1)

Note 1) Permanent damage to the device may occur if maximum values are exceeded

Functional operation should be restricted to the conditions described under normal operating conditions.

2. OPTICAL CHARACTERISTICS

The following items are measured under stable conditions. The optical characteristics should be measured in a dark room or equivalent state with the methods shown in Note (5).
Measuring equipment : TOPCON SR-3

* $T_a = 25 \pm 2$ C, $V_{DD}=3.3V$, $f_v=60Hz$, $f_{DCLK}=69.3MHz$, $I_L = 20$ mA

Item	Symbol	Condition	Min.	Typ.	Max	Unit	Note	
Contrast Ratio (5 Points)	CR	Normal Viewing Angle $\phi = 0$ $\theta = 0$	300	400	-	-	(1), (2), (5)	
Response Time at T_a (Rising + Falling)	T_{RT}		-	8	16	msec	(1), (3)	
Average Luminance of White (5 Points)	$Y_{L,AVE}$		180	200	-	cd/m ²	$I_L=20.0mA$ (1), (4)	
Color Chromaticity (CIE)	Red		R_X	TYP -0.03	0.620	TYP +0.03	-	(1), (5) SR-3
			R_Y		0.340			
	Green		G_X		0.340			
			G_Y		0.590			
	Blue		B_X		0.150			
			B_Y		0.080			
	White		W_X		0.313			
		W_Y	0.329					
Viewing Angle	Hor.	θ_L	CR ≥ 10	-	45	-	Degrees	(1), (5) SR-3
		θ_H		-	45	-		
	Ver.	ϕ_H		-	15	-		
		ϕ_L		-	35	-		
Color Gamut			-	60	-	%		
13 Points White Variation	δ_L		-	-	1.7	-	(6)	

Note 1) Definition of Viewing Angle : Viewing angle range($10 \leq C/R$)

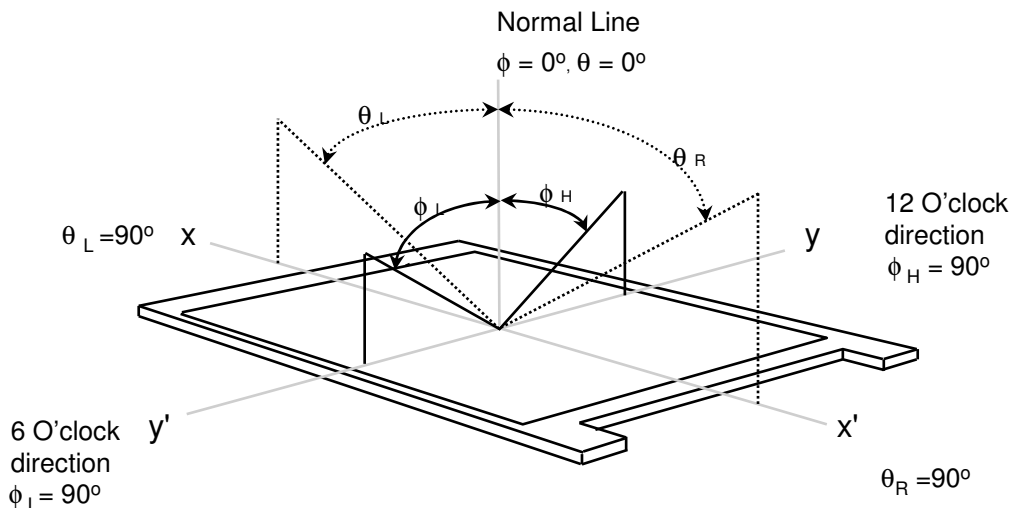

Note 2) Definition of Contrast Ratio (CR) : Ratio of gray max (Gmax) ,gray min (Gmin) at 5 points(4, 5, 7, 9, 10)

$$CR = \frac{CR(4) + CR(5) + CR(7) + CR(9) + CR(10)}{5}$$

Points : (4) , (5) , (7) , (9) , (10) at the figure of Note (6).

Note 3) Definition of Response time :

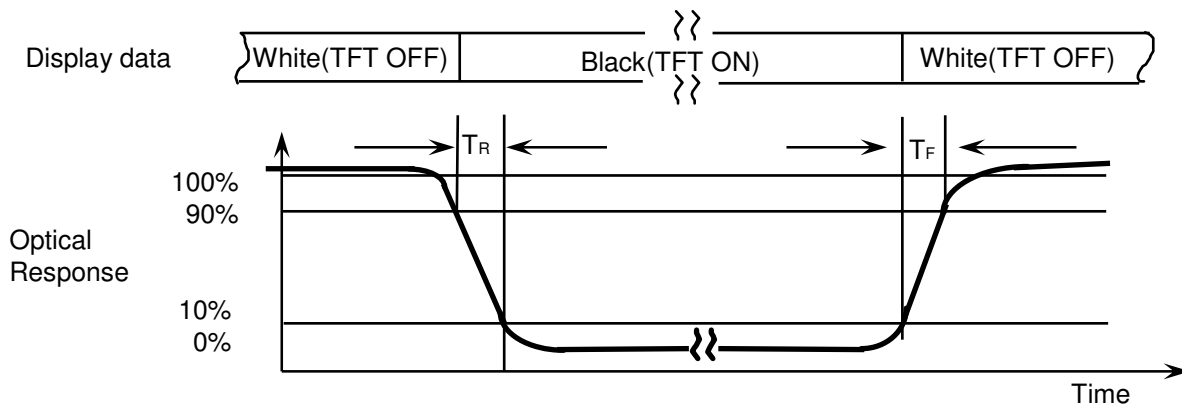

Note 4) Definition of Average Luminance of White : measure the luminance of white at 5 points.

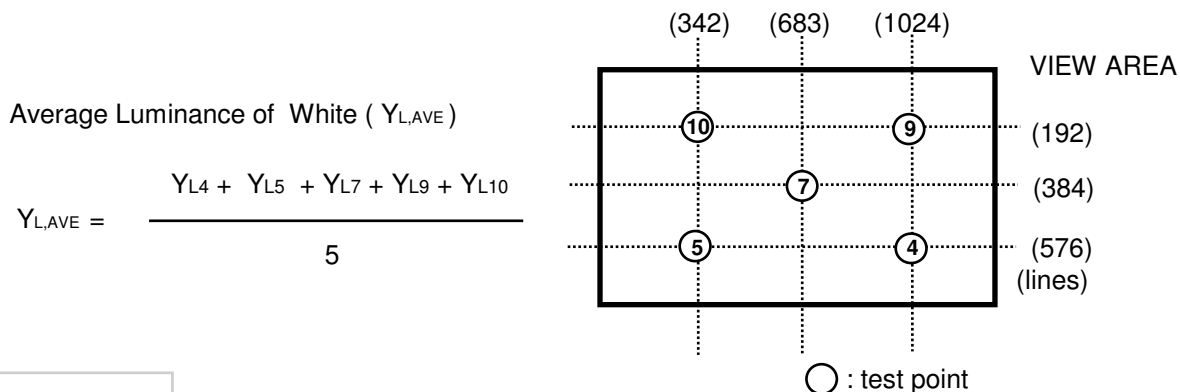

Note 5) After stabilizing and leaving the panel alone at a given temperature for 30 min , the measurement should be executed. Measurement should be executed in a stable, windless, and dark room. 30 min after lighting the backlight. This should be measured in the center of screen.
 Environment condition : $T_a = 25 \pm 2 \text{ C}$

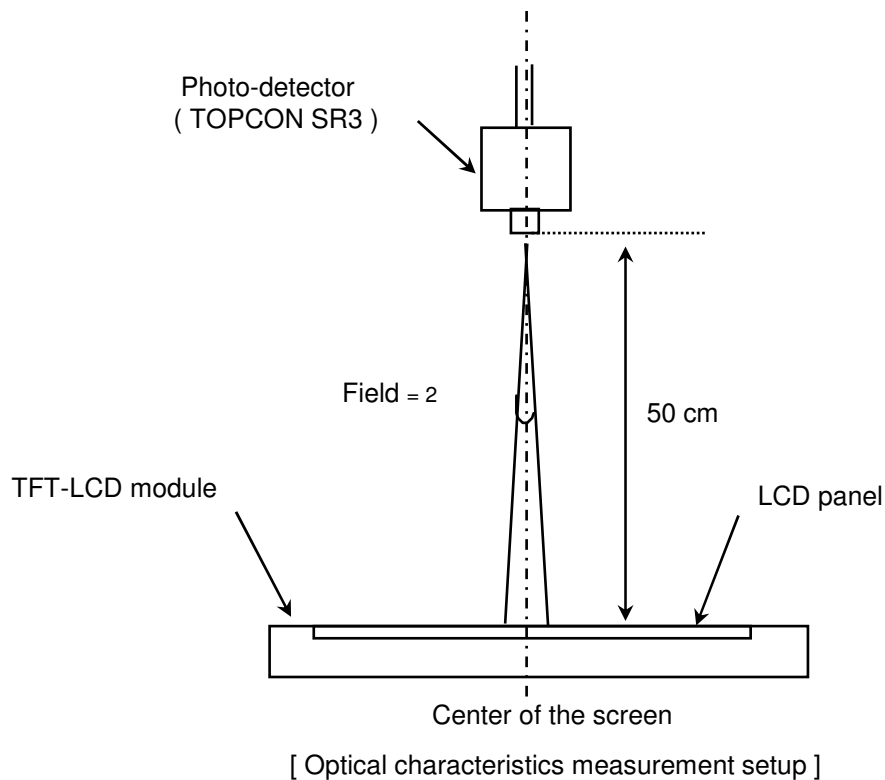

Note 6) Definition of 13 points white variation (δL), CR variation(C_{VER}) [① ~ ⑬]

$$\delta L = \frac{\text{Maximum luminance of 13 points}}{\text{Minimum luminance of 13 points}}$$

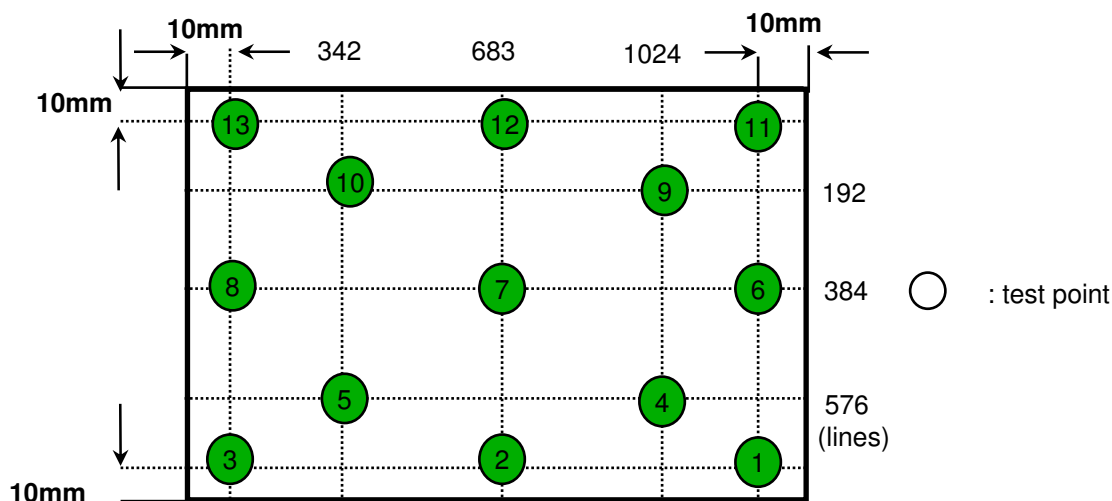

3. ELECTRICAL CHARACTERISTICS

Approval

3.1 TFT LCD MODULE

Ta= 25 ± 2 C

Item	Symbol	Min.	Typ.	Max.	Unit	Note	
Voltage of Power Supply	V _{DD}	3.0	3.3	3.6	V		
Differential Input Voltage for LVDS Receiver Threshold	High	V _{IH}	-	-	+100	mV	V _{CM} = +1.2V
	Low	V _{IL}	-100	-	-	mV	
Vsync Frequency	f _v	-	60	-	Hz		
Hsync Frequency	f _H	-	47.4	-	KHz		
Main Frequency	f _{DCLK}	67.5	72.33	80	MHz		
Rush Current	I _{RUSH}	-	-	1.5	A	(4)	
Current of Power Supply	White	I _{DD}	-	450	-	mA	(2),(3)*a
	Mosaic		-	500	-	mA	(2),(3)*b
	V. stripe		-	600	700	mA	(2),(3)*c

Note (1) Display data pins and timing signal pins should be connected.(GND = 0V)

(2) f_v = 60Hz, f_{DCLK} = 69.3 MHz, V_{DD} = 3.3V , DC Current.

(3) Power dissipation pattern

*a) White Pattern

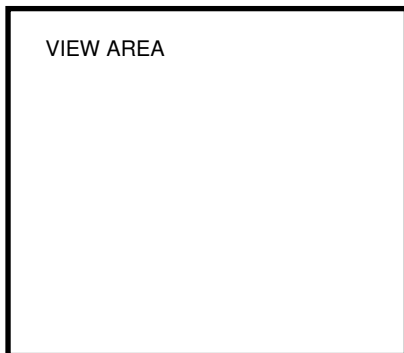

*b) Mosaic Pattern

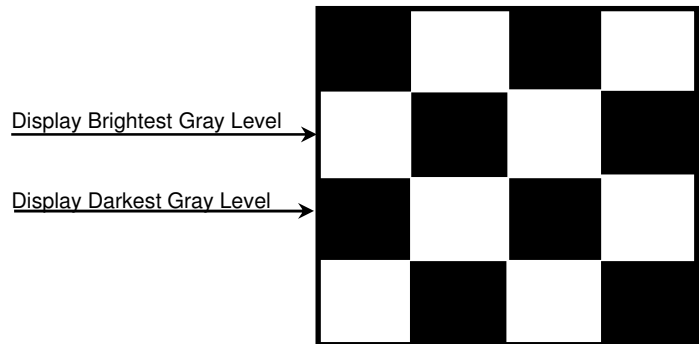

*c) 1dot Vertical stripe pattern

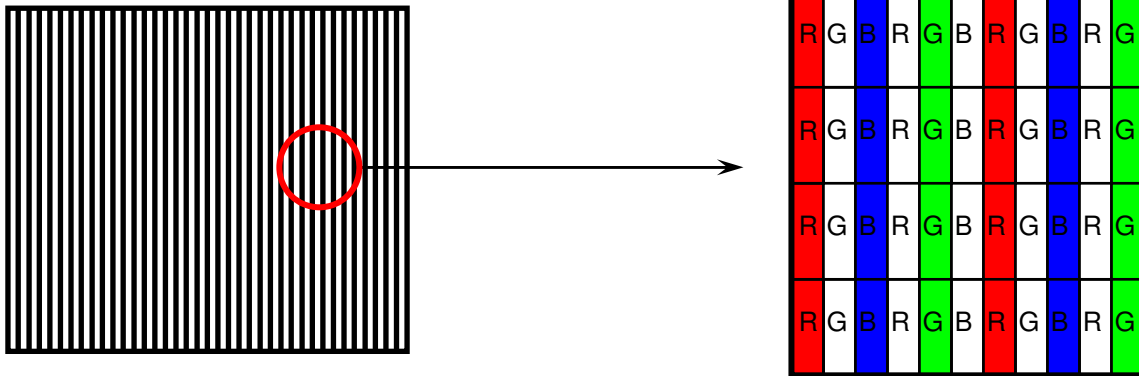

4) Rush current measurement condition

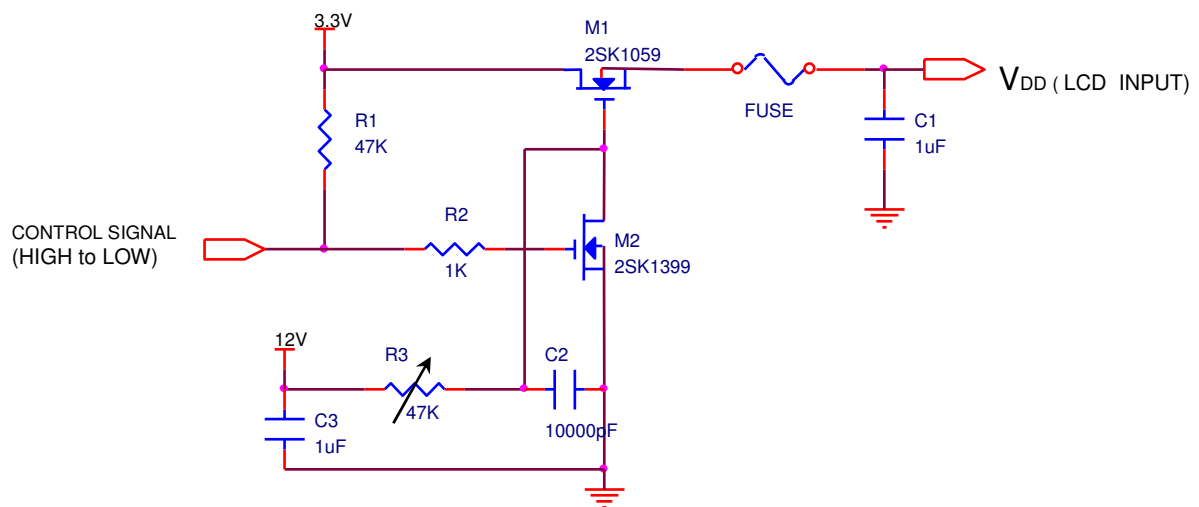

V_{DD} rising time is 470us

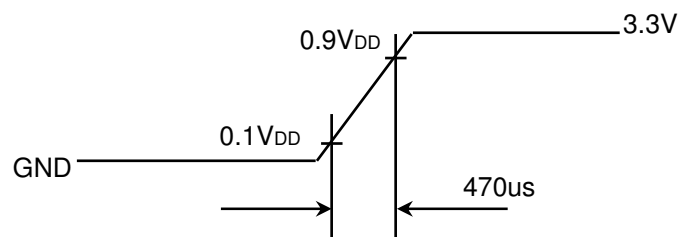

3.2 BACK-LIGHT UNIT

Ta= 25 ± 2 C

Item	Symbol	Min.	Typ.	Max.	Unit	Note
LED Forward Current	IF	-	20	-	mA	
LED Forward Voltage	VF	-	3.2	3.4	V	
LED Array Voltage	VP	-	28.8	30.6	V	VF X 9 LEDs
Power Consumption	P	-	3.90	-	W	IF X VF X54 LEDs (w/o Converter)
Operating Life Time	Hr	10,000	-	-	Hour	(1)

Note (1) Life time (Hr) of LEDs can be defined as the time in which it continues to operate under the condition Ta= 25 ± 2 C and IF = 19.0 mArms until one of the following event occurs.

1. When the brightness becomes 50% or lower than the original.

3.3 LED Driver

- LED Driver Manufacturer : Richtek

Ta= 25 ± 2 C

Item	Symbol	Min.	Typ.	Max.	Unit	Note
Input Voltage	V _{in}	6	-	24	V	
Enable Control Level	V _{en}	0	-	5	V	ON : 1.6 ~ 5V OFF : 0 ~ 1V
Burst Ratio	D	12	-	100	%	PWM freq : 100Hz~10KHz
External PWM Dimming Control Frequency (BLIM)	F _{BLIM}	0.1	-	10	kHz	

Note - Test Equipment : Fluke 45

4. BLOCK DIAGRAM

4.1 TFT LCD Module

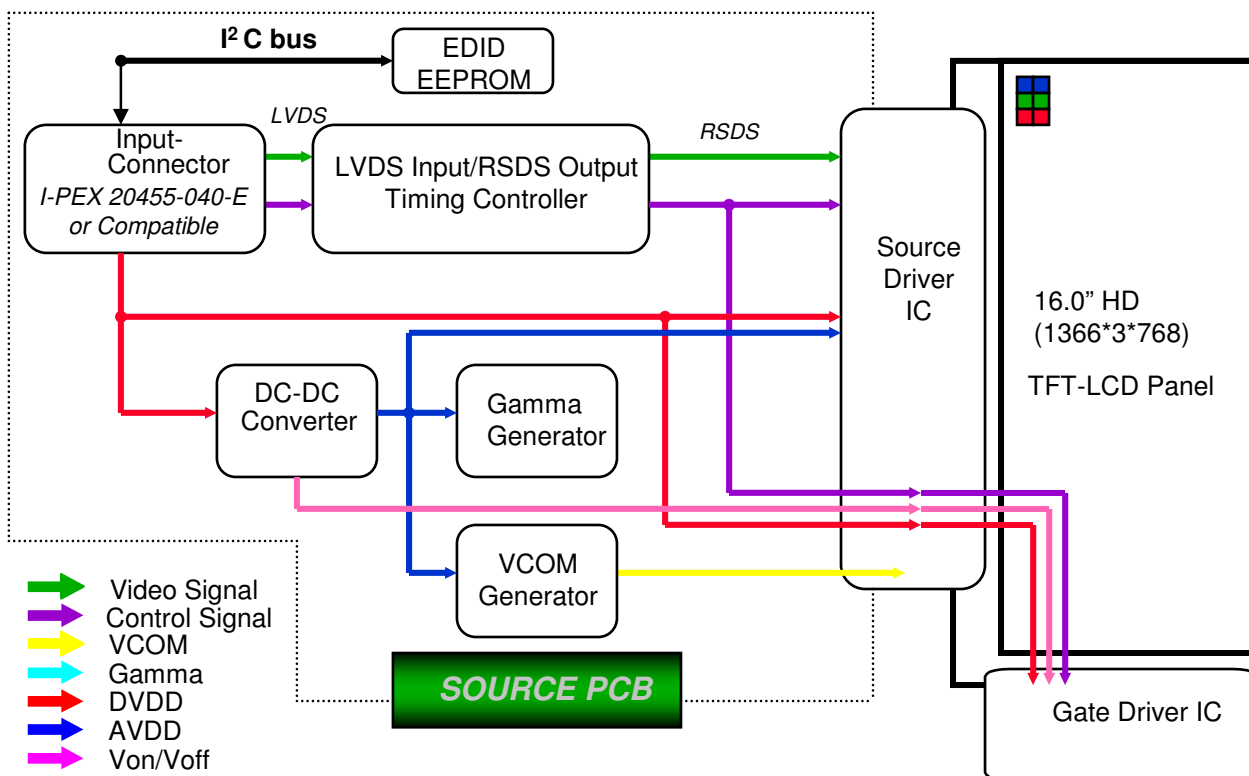

4.2 LED connection and placement

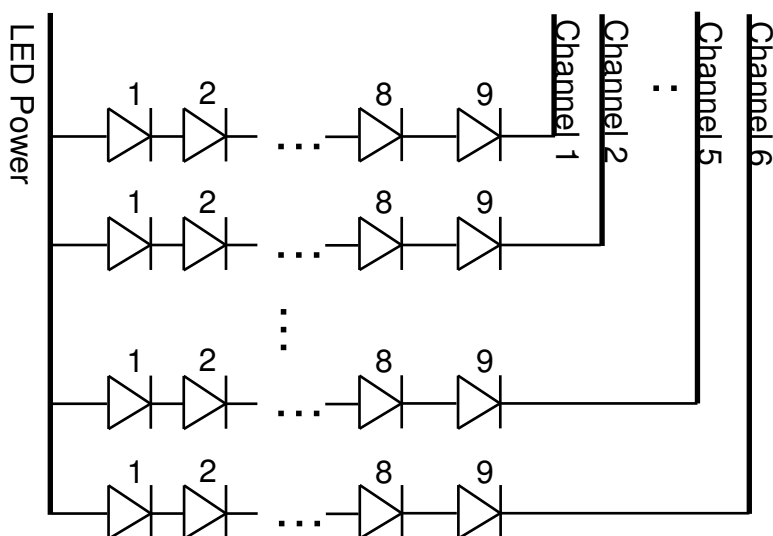

5. INPUT TERMINAL PIN ASSIGNMENT

5.1. Input Signal & Power (LVDS, Connector : I-PEX 20455-040E-0)

PIN NO	SYMBOL	FUNCTION	POLARITY	REMARK
1	NC	No Connection		
2	AVDD	POWER SUPPLY +3.3V		
3	AVDD	POWER SUPPLY +3.3V		
4	DVDD	DDC 3.3V Power		
5	NC	No Connection		
6	SCL	DDC Clock		
7	SDA	DDC data		
8	RxIN0-	LVDS Differential Data INPUT (R0-R5,G0)	Negative	
9	RxIN0+	LVDS Differential Data INPUT (R0-R5,G0)	Positive	
10	VSS	Ground		
11	RxIN1-	LVDS Differential Data INPUT (G1-G5,B0-B1)	Negative	
12	RxIN1+	LVDS Differential Data INPUT (G1-G5,B0-B1)	Positive	
13	VSS	Ground		
14	RxIN2-	LVDS Differential Data INPUT (B2-B5,Sync,DE)	Negative	
15	RxIN2+	LVDS Differential Data INPUT (B2-B5,Sync,DE)	Positive	
16	VSS	Ground		
17	RxCLK-	LVDS Differential Data INPUT (Clock)	Negative	
18	RxCLK+	LVDS Differential Data INPUT (Clock)	Positive	
19	VSS	Ground		
20	NC	No Connection		
21	NC	No Connection		
22	VSS	GND		
23	NC	No Connection		
24	NC	No Connection		
25	VSS	GND		
26	NC	No Connection		
27	NC	No Connection		
28	VSS	GND		
29	NC	No Connection		
30	NC	No Connection		

5. INPUT TERMINAL PIN ASSIGNMENT

5.1. Input Signal & Power (LVDS, Connector : I-PEX 20455-040E-0)

PIN NO	SYMBOL	FUNCTION	POLARITY	REMARK
31	VBL-	LED Ground		
32	VBL-	LED Ground		
33	VBL-	LED Ground		
34	NC	No Connection		
35	BLIM	PWM for luminance control (200~1KHz, 3.3V)		
36	BL_Enable	BL On/Off (On:2.0~3.3V, Off:0~0.5V)		
37	NC	No Connection		
38	VBL+	LED Power Supply 6V~20V		
39	VBL+	LED Power Supply 6V~20V		
40	VBL+	LED Power Supply 6V~20V		

5.2 LVDS Interface : Transmitter SN75LVDS86 or Compatible

Pin No.	Name	RGB Signal	Pin No.	Name	RGB Signal
44	TxIN0	R0	12	TxIN11	G5
45	TxIN1	R1	13	TxIN12	B0
47	TxIN2	R2	15	TxIN13	B1
48	TxIN3	R3	16	TxIN14	B2
1	TxIN4	R4	18	TxIN15	B3
3	TxIN5	R5	19	TxIN16	B4
4	TxIN6	G0	20	TxIN17	B5
6	TxIN7	G1	22	TxIN18	Hsync
7	TxIN8	G2	23	TxIN19	Vsync
9	TxIN9	G3	25	TxIN20	DE
10	TxIN10	G4	26	TxCLKIN	Clock

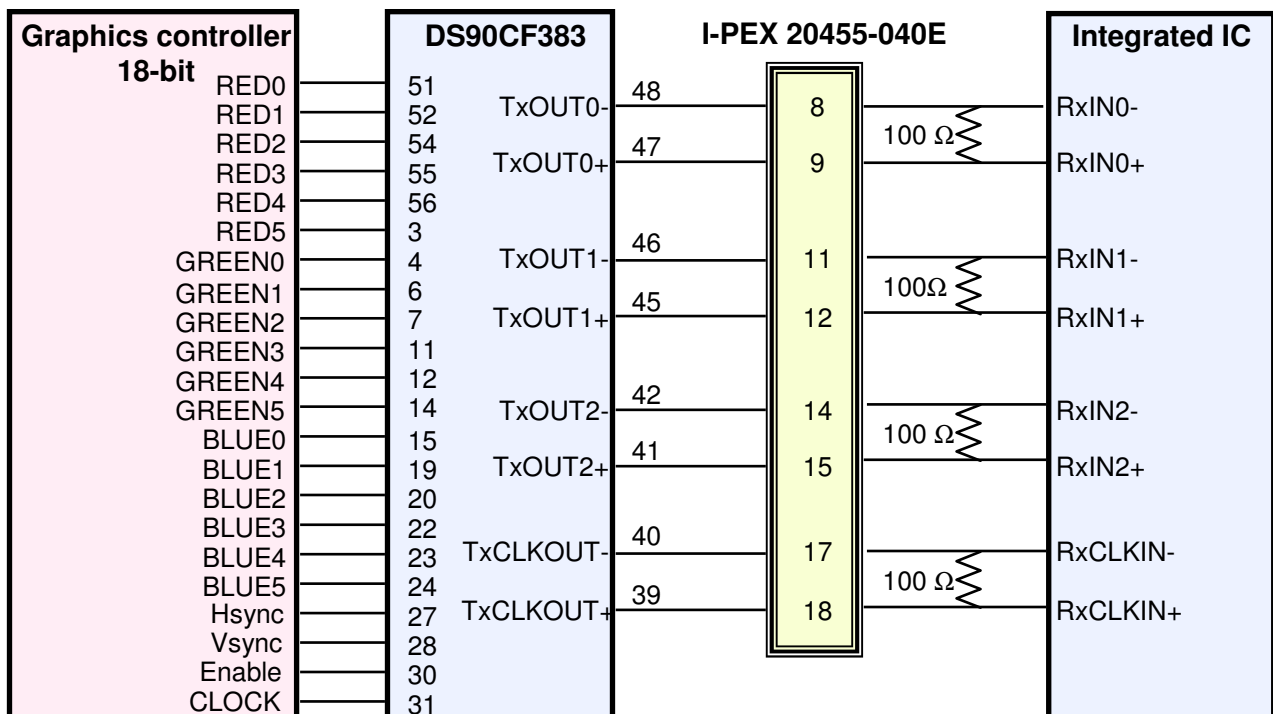
LVDS INTERFACE

Note : The LCD Module uses a 100ohm resistor between positive and negative lines of each receiver input.

5.3 Timing Diagrams of LVDS For Transmission

LVDS Receiver : Integrated T-CON

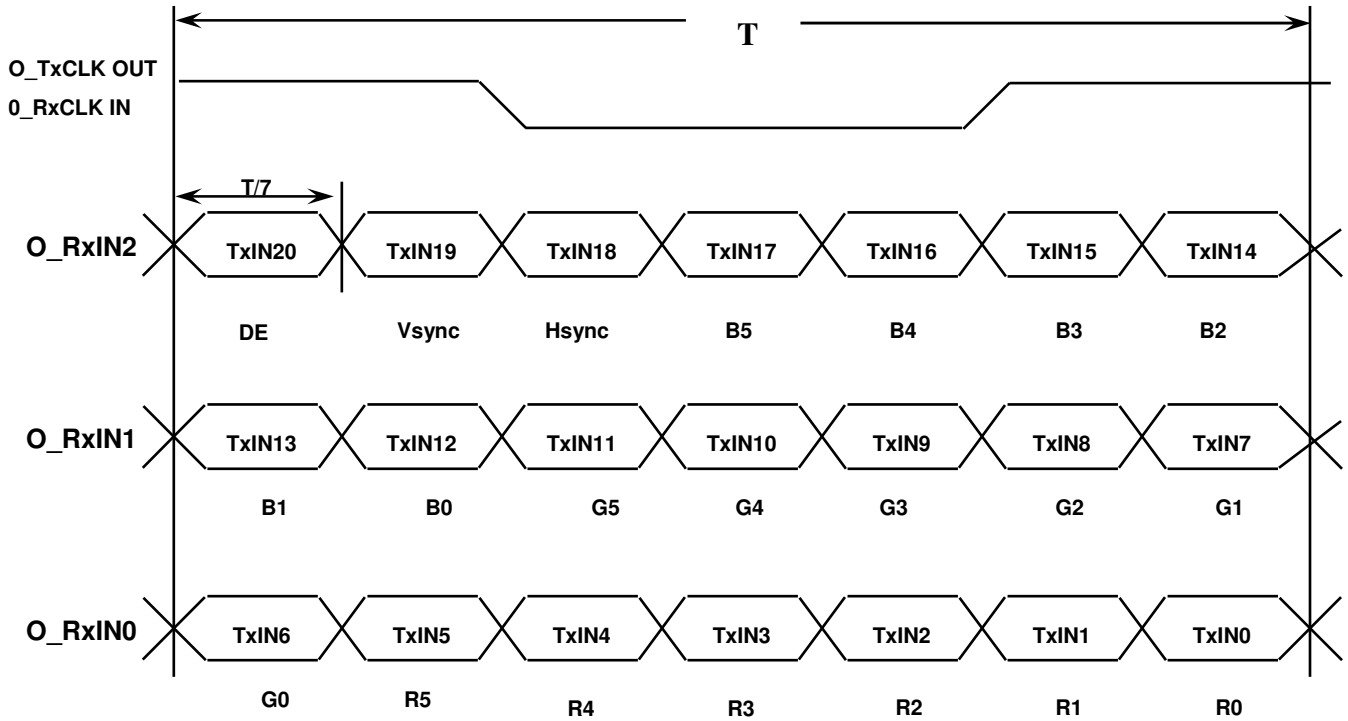

5.4 Input Signals, Basic Display Colors and Gray Scale of Each Color

Color	Display	Data Signal																	Gray Scale Level
		Red					Green					Blue							
		R0	R1	R2	R3	R4	R5	G0	G1	G2	G3	G4	G5	B0	B1	B2	B3	45	
Basic Colors	Black	0	0	0	0	0	0	0	0	0	0	0	0	0	0	0	0	0	-
	Blue	0	0	0	0	0	0	0	0	0	0	0	0	1	1	1	1	1	-
	Green	0	0	0	0	0	0	1	1	1	1	1	1	0	0	0	0	0	-
	Cyan	0	0	0	0	0	0	1	1	1	1	1	1	1	1	1	1	1	-
	Red	1	1	1	1	1	1	0	0	0	0	0	0	0	0	0	0	0	-
	Magenta	1	1	1	1	1	1	0	0	0	0	0	0	1	1	1	1	1	-
	Yellow	1	1	1	1	1	1	1	1	1	1	1	1	0	0	0	0	0	-
	White	1	1	1	1	1	1	1	1	1	1	1	1	1	1	1	1	1	-
Gray Scale Of Red	Black	0	0	0	0	0	0	0	0	0	0	0	0	0	0	0	0	0	R0
	Dark	1	0	0	0	0	0	0	0	0	0	0	0	0	0	0	0	0	R1
	↑	0	1	0	0	0	0	0	0	0	0	0	0	0	0	0	0	0	R3~R60
	:	:	:	:	:	:	:	:	:	:	:	:	:	:	:	:	:	:	
	↓	1	0	1	1	1	1	0	0	0	0	0	0	0	0	0	0	0	R61
	Light	0	1	1	1	1	1	0	0	0	0	0	0	0	0	0	0	0	R62
	Red	1	1	1	1	1	1	0	0	0	0	0	0	0	0	0	0	0	R63
	Black	0	0	0	0	0	0	0	0	0	0	0	0	0	0	0	0	0	G0
Gray Scale Of Green	Dark	0	0	0	0	0	0	1	0	0	0	0	0	0	0	0	0	0	G1
	↑	0	0	0	0	0	0	0	1	0	0	0	0	0	0	0	0	0	G2
	:	:	:	:	:	:	:	:	:	:	:	:	:	:	:	:	:	:	G3~G60
	:	:	:	:	:	:	:	:	:	:	:	:	:	:	:	:	:	:	
	↓	0	0	0	0	0	0	1	0	1	1	1	1	0	0	0	0	0	G61
	Light	0	0	0	0	0	0	0	1	1	1	1	1	0	0	0	0	0	G62
	Green	0	0	0	0	0	0	1	1	1	1	1	1	0	0	0	0	0	G63
	Black	0	0	0	0	0	0	0	0	0	0	0	0	0	0	0	0	0	B0
Gray Scale Of Blue	Dark	0	0	0	0	0	0	0	0	0	0	0	0	1	0	0	0	0	B1
	↑	0	0	0	0	0	0	0	0	0	0	0	0	0	1	0	0	0	B2
	:	:	:	:	:	:	:	:	:	:	:	:	:	:	:	:	:	:	B3~B60
	:	:	:	:	:	:	:	:	:	:	:	:	:	:	:	:	:	:	
	↓	0	0	0	0	0	0	0	0	0	0	0	0	1	0	1	1	1	B61
	Light	0	0	0	0	0	0	0	0	0	0	0	0	0	1	1	1	1	B62
	Blue	0	0	0	0	0	0	0	0	0	0	0	0	1	1	1	1	1	B63

Note 1) Definition of gray :

Rn: Red gray, Gn: Green gray, Bn: Blue gray (n=gray level)

Note 2) Input signal: 0 =Low level voltage, 1=High level voltage

5.6 Pixel Format in the display

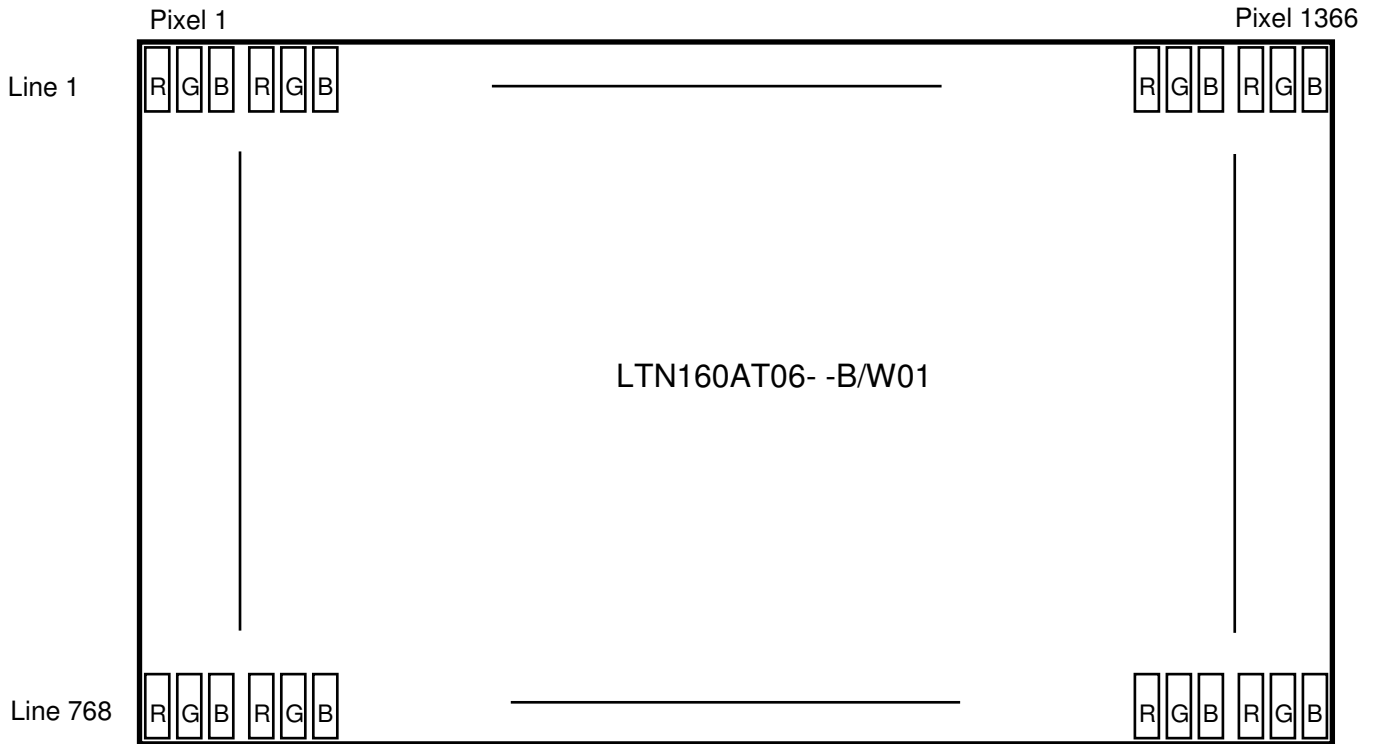

6. INTERFACE TIMING

6.1 Timing Parameters

Signal	Item	Symbol	Min.	Typ.	Max.	Unit	Note
Frame Frequency	Cycle	TV	-	790	-	Lines	
Vertical Active Display Term	Display Period	TVD	-	768	-	Lines	
One Line Scanning Time	Cycle	TH	-	1526	-	Clocks	
Horizontal Active Display Term	Display Period	THD	-	1366	-	Clocks	

6.2 Timing diagrams of interface signal

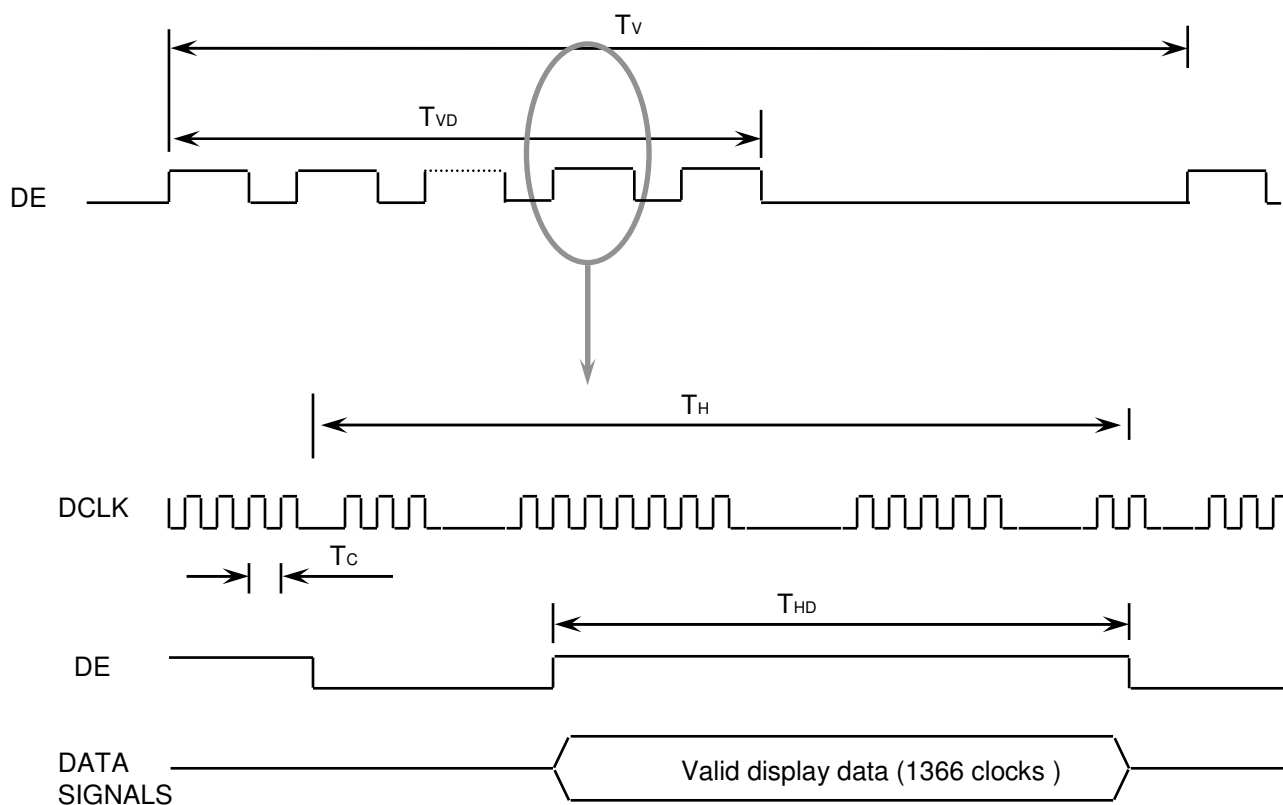

6.3 Power ON/OFF Sequence

Approval

: To prevent a latch-up or DC operation of the LCD module, the power on/off sequence should be as the diagram below.

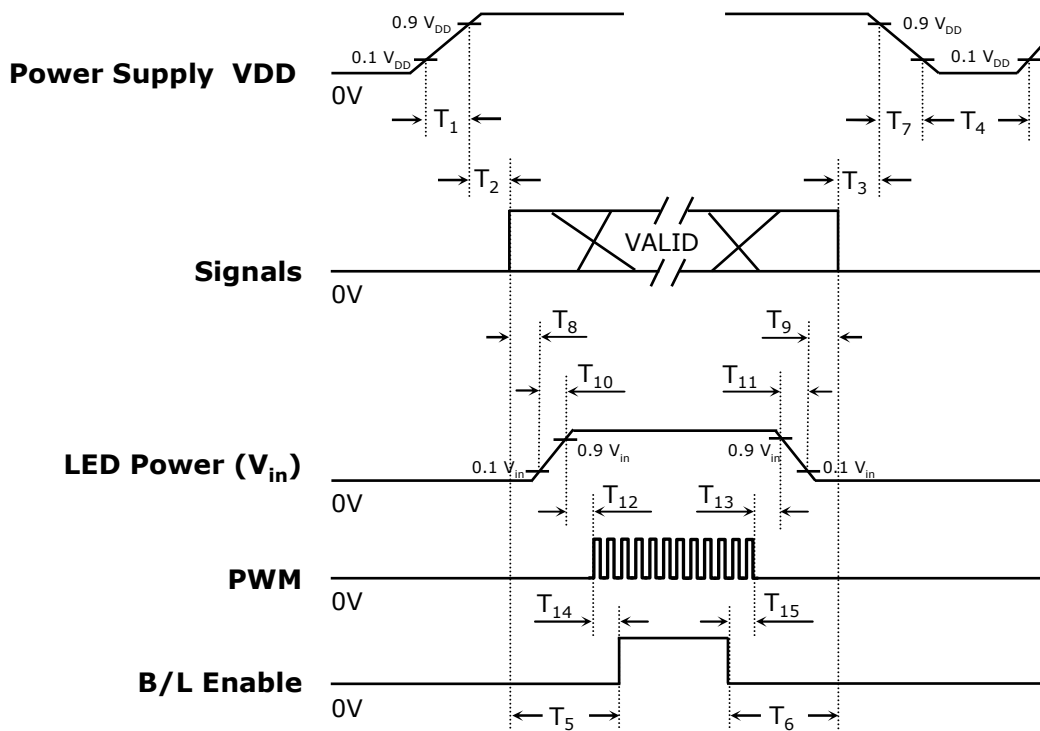

Timing (ms)	Remarks
$0.5 < T_1 \leq 10$	V _{DD} rising time from 10% to 90%
$0 < T_2 \leq 50$	Delay from V _{DD} to valid data at power ON
$0 < T_3 \leq 50$	Delay from valid data OFF to V _{DD} OFF at power Off
$500 \leq T_4$	V _{DD} OFF time for Windows restart
$200 \leq T_5$	Delay from valid data to B/L enable at power ON
$200 \leq T_6$	Delay from valid data off to B/L disable at power Off
$0 < T_7 \leq 10$	V _{DD} falling time from 90% to 10%
$10 < T_8$	Delay from valid data on to LED driver V _{in} rising time 10%
$10 < T_9$	Delay from LED driver V _{in} falling time 10% to valid data Off
$0.5 < T_{10} \leq 10$	LED V _{in} rising time from 10% to 90%
$0.5 < T_{11} \leq 10$	LED V _{in} falling time from 90% to 10%
$10 < T_{12}$	Delay from LED driver V _{in} rising time 90% to PWM ON
$10 < T_{13}$	Delay from PWM Off to LED driver V _{in} falling time 10%
$10 < T_{14}$	Delay from PWM ON to B/L Enable ON
$10 < T_{15}$	Delay from B/L Enable Off to PWM Off

Note : Backlight may flash if interface signal remains floating state at invalid period.



NOTE.

- (1) The supply voltage of the external system for the module input should be the same as the definition of V_{DD} .
- (2) Apply the LED On within the LCD operation range. When the back-light turns on before the LCD operation or the LCD turns off before the back-light turns off, the display may momentarily become white.
- (3) In case of $V_{DD} = \text{off level}$, please keep the level of input signals on the low or keep a high impedance.
- (4) T_7 should be measured after the module has been fully discharged between power off and on period.
- (5) Interface signal shall not be kept at high impedance when the power is on.
- (6) T_8, T_9 startup sequence is Backlight Power On \rightarrow PWM for LED driver \rightarrow Enable.
If the dimming signal is applied after the Enable pin, the device will not perform the soft start again, in fact it will start switching with the maximum current limit in order to recover the output voltage.

7. Mechanical Outline Dimension

Approval

[Refer to the next page]

Doc.No.	LTN160AT06-B/W01	Rev.No	04-A00-G-100324	Page	23 / 32
----------------	------------------	---------------	-----------------	-------------	---------

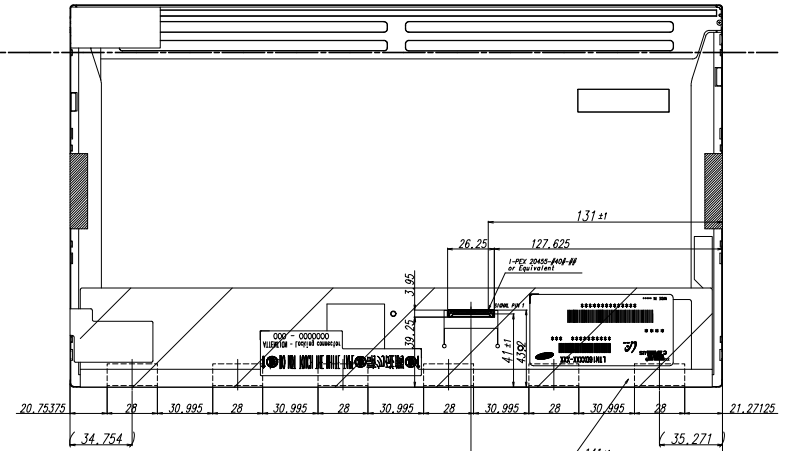
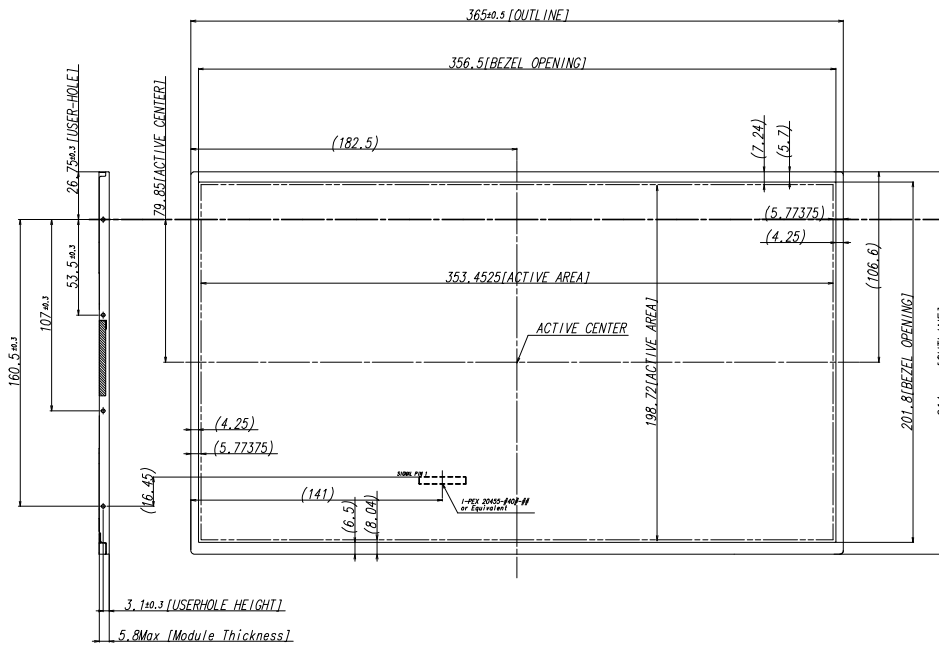

IN THIS AREA, THE THICKNESS IS OVER 6.5mm WITH NO PRESSURE FORCE.
 IT IS ALLOWED TO PRESS BY 6.5mm

- * NOTE
- SIGNAL INTERFACE CONNECTOR TO BE SPECIFIED AS BELOW.
 - MAKER : 1-PEX OR COMPATIBLE
 - INPUT CONNECTOR : 1-PEX 20455-#04-# or EQUIVALENT
 - LED CONNECTOR FOR BACKLIGHT TO BE SPECIFIED AS BELOW.
 - MAKER : UUV Electronics (TBD)
 - PART NO : 51441-1041 (TBD)
 - ALLOWED DEPTH OF USERHOLE SCREW INSERTION IS MAX 2.5mm
 - TORQUE SPEC : MAX 2.0 Kgf-cm (5TIMES)

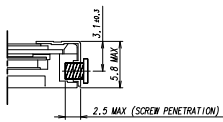
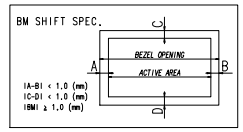

<USER HOLE SCREW PENETRATION DEPTH>

REV	DATE	DESCRIPTION OF REVISION	REASON	CHK'D BY

REV	DATE	DESCRIPTION OF REVISION	REASON	CHK'D BY

SAMSUNG ELECTRONICS

8. PACKING

1. CARTON(Internal Package)

(1) Packing Form

Corrugated Cardboard box and Corrupad form as shock absorber

(2) Packing Method

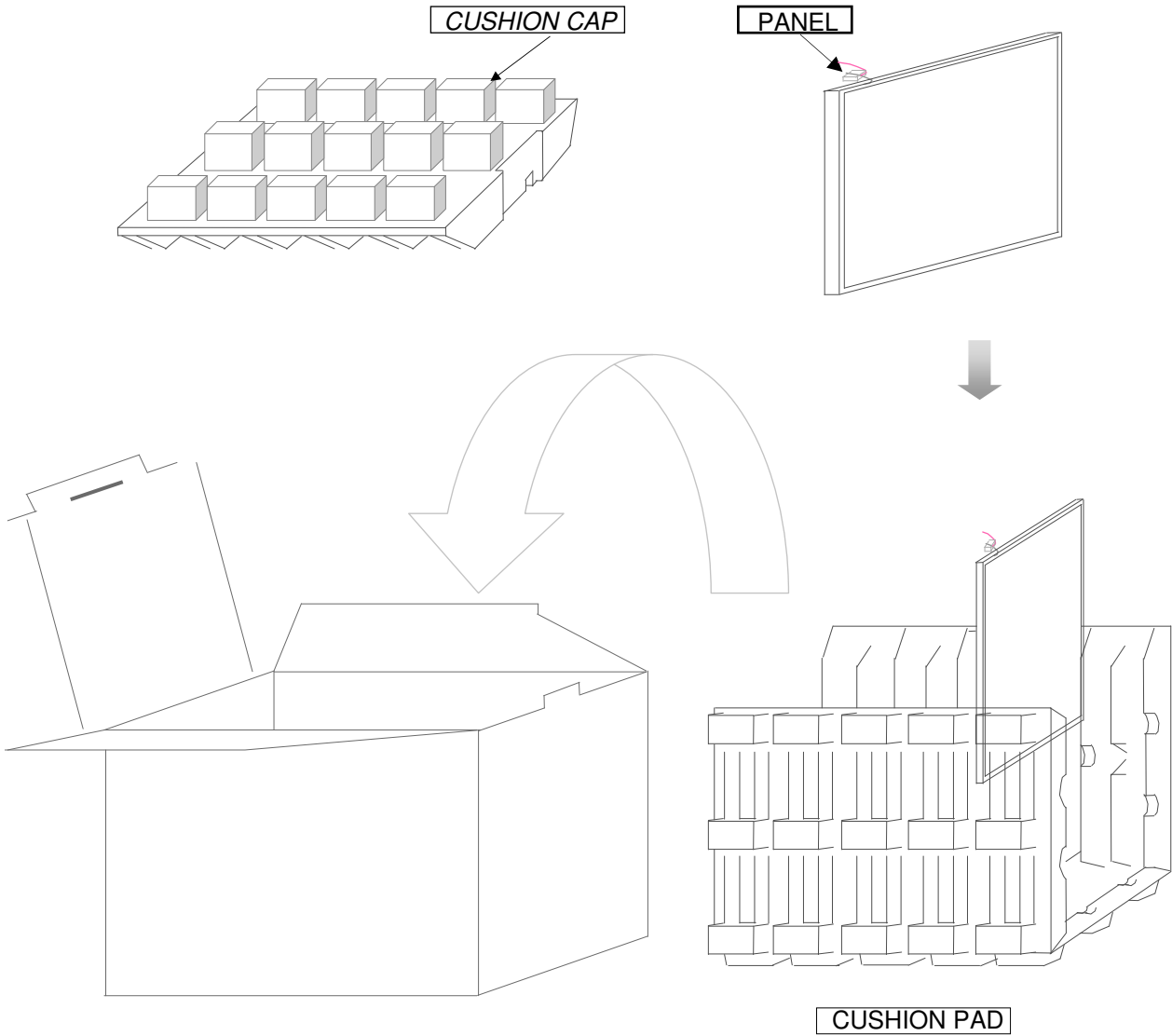

- Note 1) Total Weight : Approximately : 7.5 kg
- 2) Acceptance number of piling : 10 sets
- 3) Carton size : 463(W) x 359(D) x 333(H)

(3)Packing Material

No	Part name	Quantity
1	Static electric protective sack	10 pcs
2	Packing case (Inner box) included shock absorber	1 set
3	Pictorial marking	2 pcs
4	Carton	1 set

9. MARKINGS & OTHERS

A nameplate bearing followed by is affixed to a shipped product at the specified location on each product.

(1)Parts number : LTN160AT06

(2)Revision code : 3 letters

(3)Lot number : X X X X XX XX XX XXX

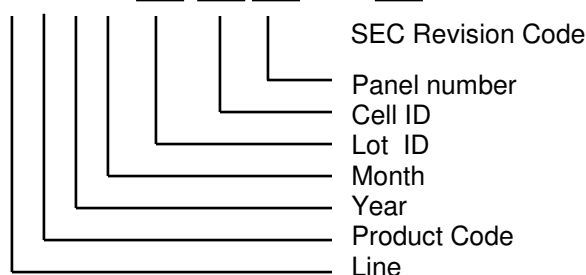

(4) Nameplate Indication

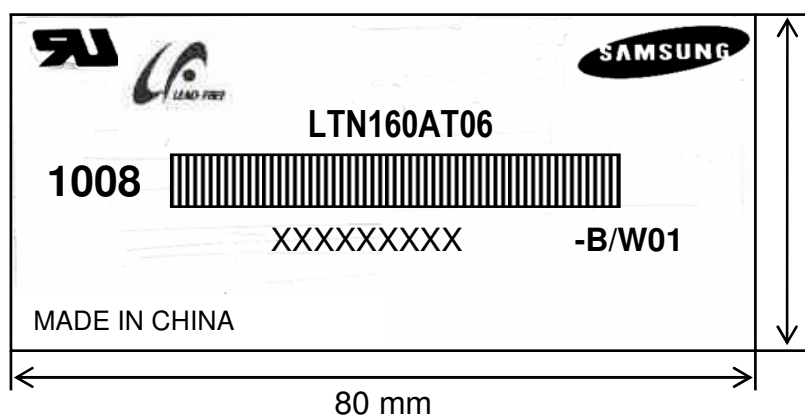

Parts name : LTN160AT06
 Lot number : XXXXXXXXXXXX
 Inspected work week : 1008 (2010 year 8th week)
 Product Revision Code : B/W01

(5) High voltage caution notice

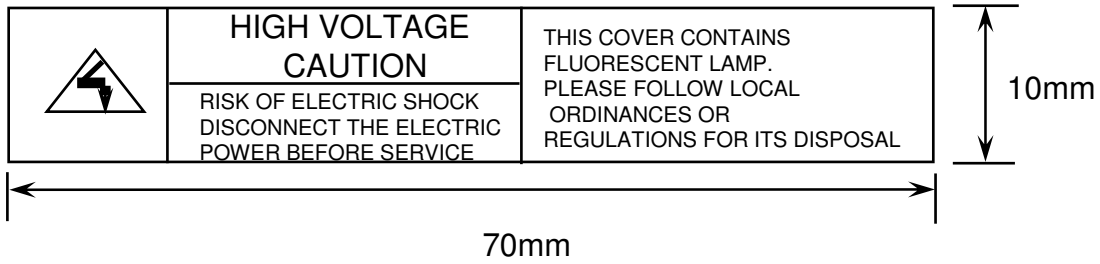

(6) Packing small box attach

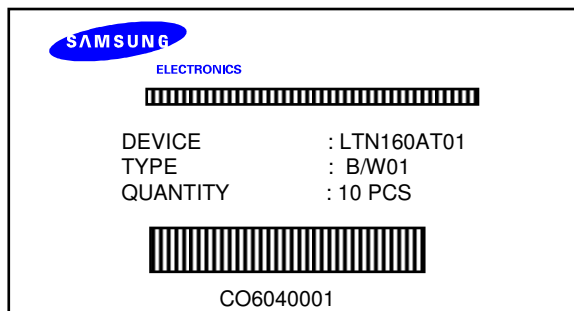

10. GENERAL PRECAUTIONS

1. Handling

- (a) When the module is assembled, It should be attached to the system firmly using every mounting holes. Be careful not to twist and bend the modules.
- (b) Refrain from strong mechanical shock and / or any force to the module. In addition to damage, this may cause improper operation or damage to the module.
- (c) Note that polarizers are very fragile and could be easily damaged. Do not press or scratch the surface harder than a HB pencil lead.
- (d) Wipe off water droplets or oil immediately. If you leave the droplets for a long time, Staining and discoloration may occur.
- (e) If the surface of the polarizer is dirty, clean it using some absorbent cotton or soft cloth.
- (f) The desirable cleaners are water, IPA(Isopropyl Alcohol) or Hexane. Do not use Ketone type materials(ex. Acetone), Ethyl alcohol, Toluene, Ethyl acid or Methyl chloride. It might permanent damage to the polarizer due to chemical reaction.
- (g) If the liquid crystal material leaks from the panel, it should be kept away from the eyes or mouth. In case of contact with hands, legs or clothes, it must be washed away thoroughly with soap.
- (h) Protect the module from static, it may cause damage to the C-MOS Gate Array IC.
- (i) Use fingerstalls with soft gloves in order to keep display clean during the incoming inspection and assembly process.
- (j) Do not disassemble the module.
- (k) Do not pull or fold the lamp wire.
- (l) Do not adjust the variable resistor which is located on the back side.
- (m) Protection film for polarizer on the module shall be slowly peeled off just before use so that the electrostatic charge can be minimized.
- (n) Pins of I/F connector shall not be touched directly with bare hands.

2. STORAGE

- (a) Do not leave the module in high temperature, and high humidity for a long time.
It is highly recommended to store the module with temperature from 0 to 35 °C and relative humidity of less than 70%.
- (b) Do not store the TFT-LCD module in direct sunlight.
- (c) The module shall be stored in a dark place. It is prohibited to apply sunlight or fluorescent light during the store.

3. OPERATION

- (a) Do not connect, disconnect the module in the “ Power On” condition.
- (b) Power supply should always be turned on/off by following item 6.3
“ Power on/off sequence “.
- (c) Module has high frequency circuits. Sufficient suppression to the electromagnetic interference shall be done by system manufacturers. Grounding and shielding methods may be important to minimize the interference.
- (d) The standard limited warranty is only applicable when the module is used for general notebook applications. If used for purposes other than as specified, SEC is not to be held reliable for the defective operations. It is strongly recommended to contact SEC to find out fitness for a particular purpose.

4. OTHERS

- (a) Ultra-violet ray filter is necessary for outdoor operation.
- (b) Avoid condensation of water. It may result in improper operation or disconnection of electrode.
- (c) Do not exceed the absolute maximum rating value. (the supply voltage variation, input voltage variation, variation in part contents and environmental temperature, so on)
Otherwise the module may be damaged.
- (d) If the module displays the same pattern continuously for a long period of time, it can be the situation when the image “sticks” to the screen.
- (e) This module has its circuitry PCB's on the rear side and should be handled carefully in order not to be stressed.

11. EDID

Approval

Address (HEX)	FUNCTION	Value	BIN	DEC	ASCII or Data	Notes
		HEX				
00	Header	00	00000000	0		EDID Header
01		FF	11111111	255		
02		FF	11111111	255		
03		FF	11111111	255		
04		FF	11111111	255		
05		FF	11111111	255		
06		FF	11111111	255		
07		00	00000000	0		
08	ID Manufacturer Name	4C	01001100	76	S	3 character ID
09		A3	10100011	163	E C	
0A	ID Product Code	4D	01001101	77	[M]	
0B		52	01010010	82	[R]	
0C	32-bit serial no.	00	00000000	0		
0D		00	00000000	0		
0E		00	00000000	0		
0F		00	00000000	0		
10	Week of manufacture	00	00000000	0		
11	Year of manufacture	13	00010011	19	2009	2008
12	EDID Structure Ver.	01	00000001	1	1	EDID Ver. 1.0
13	EDID revision #	03	00000011	3	3	EDID Rev. 3
14	Video input definition	80	10000000	128		
15	Max H image size	23	00100011	35	35	35 cm(approx)
16	Max V image size	14	00010100	20	20	20 cm(approx)
17	Display Gamma	78	01111000	120	2.2	Gamma 2.2
18	Feature support	0A	00001010	10		
19	Red/green low bits	C0	11000000	192		10000111
1A	Blue/white low bits	A5	10100101	165		11111110
1B	Red x/ high bits	9E	10011110	158	0.620	Red x 0.580= 1001010010
1C	Red y	57	01010111	87	0.340	Red y 0.340= 0101011100
1D	Green x	57	01010111	87	0.340	Green x 0.310= 0100111101
1E	Green y	97	10010111	151	0.590	Green y 0.550= 1000110011
1F	Blue x	26	00100110	38	0.150	Blue x 0.155= 0010011111
20	Blue y	14	00010100	20	0.080	Blue y 0.155= 0010011111
21	White x	50	01010000	80	0.313	White x 0.313= 0101000001
22	White y	54	01010100	84	0.329	White y 0.329= 0101010001
23	Established timing 1	00	00000000	0		
24	Established timing 2	00	00000000	0		
25	Established timing 3	00	00000000	0		

11. EDID

Approval

26	Standard timing #1	01	00000001	1		not used
27		01	00000001	1		
28	Standard timing #2	01	00000001	1		not used
29		01	00000001	1		
2A	Standard timing #3	01	00000001	1		not used
2B		01	00000001	1		
2C	Standard timing #4	01	00000001	1		not used
2D		01	00000001	1		
2E	Standard timing #5	01	00000001	1		not used
2F		01	00000001	1		
30	Standard timing #6	01	00000001	1		not used
31		01	00000001	1		
32	Standard timing #7	01	00000001	1		not used
33		01	00000001	1		
34	Standard timing #8	01	00000001	1		not used
35		01	00000001	1		
36	Detailed timing/monitor descriptor #1	41	01000001	65	72.33	Main clock= 72.33 MHz
37		1C	00011100	28		
38		56	01010110	86	1366	Hor active=1366 pixels
39		A0	10100000	160	160	Hor blanking=160 pixels
3A		50	01010000	80		4bit : 4bit
3B		00	00000000	0	768	Vertical active=768 lines
3C		16	00010110	22	22	Vertical blanking=22 lines
3D		30	00110000	48		4bit : 4bit
3E		30	00110000	48	48	
3F		20	00100000	32	32	H sync. Width=32 pixels
40		25	00100101	37	2 5	V sync. Offset=2 lines V sync. Width=5 lines
41		00	00000000	0		2bit : 2bit :2bit :2bit
42		61	01100001	97	353	H image size= 353 mm(approx)
43		C6	11000110	198	198	V image size = 198 mm(approx)
44		10	00010000	16		
45		00	00000000	0		No Horizontal Border
46		00	00000000	0		No Vertical Border
47	19	00011001	25			
48	Detailed timing/monitor descriptor #2	00	00000000	0		Manufacturer Specified (Timing)
49		00	00000000	0		
4A		00	00000000	0		
4B		0F	00001111	15		
4C		00	00000000	0		
4D		00	00000000	0		Value=HSPWmin / 2
4E		00	00000000	0		Value=HSPWmax / 2
4F		00	00000000	0		Value=Thbpmin / 2
50		00	00000000	0		Value=Thbpmax / 2
51		00	00000000	0		Value=VSPWmin / 2
52		00	00000000	0		Value=VSPWmax / 2
53		00	00000000	0		Value=Tvbpmmin / 2
54		00	00000000	0		Value=Tvbpmmax / 2
55		1E	00011110	30		Thpmin=value*2 + HA pixelclks
56		B4	10110100	180		Thpmax=value*2 + HA pixelclks
57		02	00000010	2		Tvpmin=value*2 + VA lines
58		74	01110100	116		Tvpmax=value*2 + VA lines
59	00	00000000	0		Module revision	

11. EDID

Approval

5A	Detailed timing/monitor descriptor #3	00	00000000	0		ASCII Data String Tag
5B		00	00000000	0		
5C		00	00000000	0		
5D		FE	11111110	254		
5E		00	00000000	0		
5F		53	01010011	83	[S]	
60		41	01000001	65	[A]	
61		4D	01001101	77	[M]	
62		53	01010011	83	[S]	
63		55	01010101	85	[U]	
64		4E	01001110	78	[N]	
65		47	01000111	71	[G]	
66		0A	00001010	10	[^]	
67		20	00100000	32	[]	
68		20	00100000	32	[]	
69		20	00100000	32	[]	
6A	20	00100000	32	[]		
6B	20	00100000	32	[]		
6C	Detailed timing/monitor descriptor #4	00	00000000	0		Monitor Name Tag (ASCII)
6D		00	00000000	0		
6E		00	00000000	0		
6F		FE	11111110	254		
70		00	00000000	0		
71		31	00110001	49	[1]	
72		36	00110110	54	[6]	
73		30	00110000	48	[0]	
74		41	01000001	65	[A]	
75		54	01010100	84	[T]	
76		30	00110000	48	[0]	
77		36	00110110	54	[6]	
78		2D	00101101	45	[-]	
79		41	01000001	65	[A]	
7A		30	00110000	48	[0]	
7B		31	00110001	49	[1]	
7C	0A	00001010	10	[^]		
7D	20	00100000	32	[]		
7E	Extension Flag	00	00000000	0		
7F	Checksum	9E	10011110	158		