

mass integrated

global part distribution • product lifecycle partner
excess inventory management • value-ad service provider



Data sheet provided by Mass Integrated

massintegrated.com • displayalliance.com

Please call +1.978.465.6190
Email: sales@massintegrated.com



ISO 9001: 2008

Mass Integrated complies with all DMCA takedown notices. Please send a formal DMCA Takedown Notice to Mass Integrated Systems, Inc. • 18 Henry Graf Jr. Road, Unit 1 • Newburyport, MA 01950.

ELECTRONICS

TO : General

DATE : Jun. 17. 2005

*SAMSUNG TFT-LCD***MODEL NO. : LTV350QV-F05**

Any Modification of Spec is not allowed without SEC's permission.

Approved by : S.C. OH**LCD DIVISION****Samsung Electronics Co., Ltd.**

Revision History

Date	Rev. No.	Page	Summary
Jun.17.2005	000		Rev.000 was issued.

Contents

General Description	-----	(5)
1. Absolute Maximum Ratings	-----	(6)
1.1 Absolute Ratings Of Environment		
1.2 Electrical Absolute Ratings		
2. Optical Characteristics	-----	(8)
3. Electrical Characteristics	-----	(12)
3.1 TFT-LCD Module		
3.2 Back-light Unit		
4. Touch Screen Panel Specification	-----	(14)
4.1 Electrical Characteristics		
4.2 Mechanical & Reliability Characteristics		
5. Block Diagram	-----	(15)
5.1 TFT-LCD Module(Interface System Structure) with Back Light Unit		
5.2 Touch Screen Panel		
5.3 Back-light Unit		
6. Input Terminal Pin Assignment	-----	(17)
6.1 Input Signal & Power		
6.2 Back-Light Unit		
6.3 Touch screen panel		
6.4 Input Signal, Basic Display colors and Gray Scale of Each Colors		
7. Operation Specifications	-----	(20)
7.1 Serial Peripheral Interface		
7.2 Data Format for 24bit RGB Interface		
7.3 24bit RGB Interface Timing		
7.4 Electrical Specifications		
8. Command List & Instruction Descriptions	-----	(26)
8.1 Command List		
8.2 Instruction Descriptions		
9. Power On/Off Sequence	-----	(27)
9.1 Power On Sequence		
9.2 Power Off Sequence		
10. Reliability Test Result	-----	(31)
11. Outline Dimension	-----	(32)
12. Packing	-----	(33)
13. Marking & Others	-----	(34)
14. General Precaution	-----	(35)

- 14.1 Handling
- 14.2 Storage
- 14.3 Operation
- 14.4 Others

General Description

* Description

LTV350QV-F05 is a TMR(Transmissive with Micro Reflective) type color active matrix TFT (Thin Film Transistor) liquid crystal display (LCD) that uses amorphous silicon TFT as a switching devices. This model is composed of a TFT-LCD module, a driver circuit and a back-light unit and a touch screen panel(TSP).

The resolution of a 3.5" contains 320RGBx240 dots and can display up to 16.7M colors.

* Features

- Transmissive with Micro Reflective type and back-light with six LEDs are available.
- Visible in outdoor & back-light off condition with reflectivity.
- Using the Touch Screen Panel(Film to Film-Glass type).
- TN(Twisted Nematic) mode.
- Line inversion mode with stripe type.
- 24bit RGB Interface + Serial Peripheral Interface(SPI)
- DE(Data Enable, Dotclk) mode, SYNC(Vsync, Hsync, Dotclk) mode
- Gate Driver IC embeded on Panel(Double ASG)

* Applications

- Display terminals for DSC(Digital Still Camera), PMP(Portable Multimedia Player) application products.

* General information

Items	Specification	Unit	Note
Display area	70.08(H) x 52.56(V)	mm	-
Driver element	a-Si TFT active matrix	-	-
Display colors	16.7M	colors	-
Number of pixels	320RGB(H) x 240(V)	dot	-
Pixel arrangement	stripe type	-	-
Pixel pitch	0.219(H) x 0.219(V)	mm	-
Display mode	Normally White	-	-
Viewing direction	6	o'clock	-

* Mechanical information

Item	Min.	Typ.	Max.	Unit	Note	
Module size	Horizontal(H)	76.70	76.90	77.10	mm	-
	Vertical(V)	63.70	63.90	64.10	mm	(1)
	Depth(D)	4.05	4.25	4.45	mm	(1)
Weight	-	43	48	g	-	

Note (1) Not include FPC.

Refer to the Outline Dimension in the "11.Outline Dimension" for further information.

(2) Touch Screen Panel and Back-light unit are included.

1. Absolute Maximum Ratings

1.1 Absolute Ratings of Environment

Item	Symbol	Min.	Max.	Unit	Note
Storage temperature	T _{STG}	-30	70	°C	(1)
Operating temperature (Ambient temperature)	T _{OPR}	-20	60	°C	(1),(2)

Note (1) 95 % RH Max. (40 °C ≥ Ta)

Maximum wet-bulb temperature at 39 °C or less. (Ta > 40 °C) No condensation.

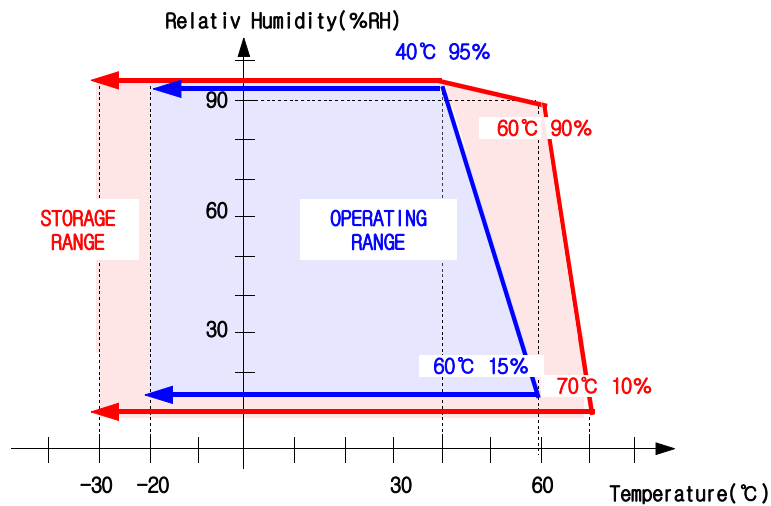

(2) In case of below 0°, the response time of liquid crystal (LC) becomes slower and the color of panel becomes darker than normal one.

Level of retardation depends on temperature, because of LC's characteristics.

1.2 Electrical Absolute Ratings

(1) TFT-LCD Module

(Ta = 25 ± 2°C, V_{SS}=GND=0)

Characteristics	Symbol	Min.	Max.	Unit	Note
Digital supply voltage	V _{CC}	-0.3	5.0	V	-
Analog supply voltage	DDVDH	-0.3	7.0	V	-
Gate On voltage	V _{GH}	-0.3	22.0	V	-
Gate Off voltage	V _{GL}	-18.5	0.3	V	-

(2) Back-Light Unit

(Ta = 25 ± 2°C)

Item	Symbol	Min.	Max.	Unit.	Note
Current	I _B		25	mA	(1)

Note (1) Permanent damage to the device may occur if maximum values are exceeded or reverse voltage is loaded.

Functional operation should be restricted to the conditions described under normal operating conditions.

2. Optical Characteristics

The following items are measured under stable conditions. The optical characteristics should be measured in a dark room or equivalent state with the methods shown in Note (1).

Measuring equipment: LCD-5000, BM-5A, BM-7, PR-650, EZ-Contrast

(Ta = 25 ± 2°C, V_{CC} = V_{CI} = 3.3V, I_B = 20mA)

Item	Symbol	Condition	Min.	Typ.	Max.	Unit	Note	
Contrast ratio (Center point)	C/R	NOTE (1) φ = 0 θ = 0 Normal Viewing Angle B/L On	150	300	-	-	(2) BM-5A	
Luminance of white (Center point)	YL		150	200	-	cd/m ²	(3) BM-5A	
Response time	Rising:Tr		Tr+Tf	-	25	30	msec	(4) BM-7
	Falling:Tf							
Color chromaticity (CIE 1931)	White		Wx	0.28	0.33	0.38	-	(5) PR-650
			Wy	0.29	0.34	0.39		
	Red		Rx	0.57	0.62	0.67		
			Ry	0.31	0.36	0.41		
	Green		Gx	0.29	0.34	0.39		
			Gy	0.51	0.56	0.61		
	Blue	Bx	0.1	0.15	0.2			
		By	0.09	0.14	0.19			
Viewing angle	Hor.	θL	55	60	Degrees	(6) Ez-Contrast		
		θR	55	60				
	Ver.	φH	45	50				
		φL	50	55				

Note (1) Test Equipment Setup

After stabilizing and leaving the panel alone at a given temperature for 30 min , the measurement should be executed. Measurement should be executed in a stable, windless, and dark room. 30 min after lighting the back-light. This should be measured in the center of screen.

Environment condition : $T_a = 25 \pm 2 \text{ }^\circ\text{C}$

Back-Light On condition

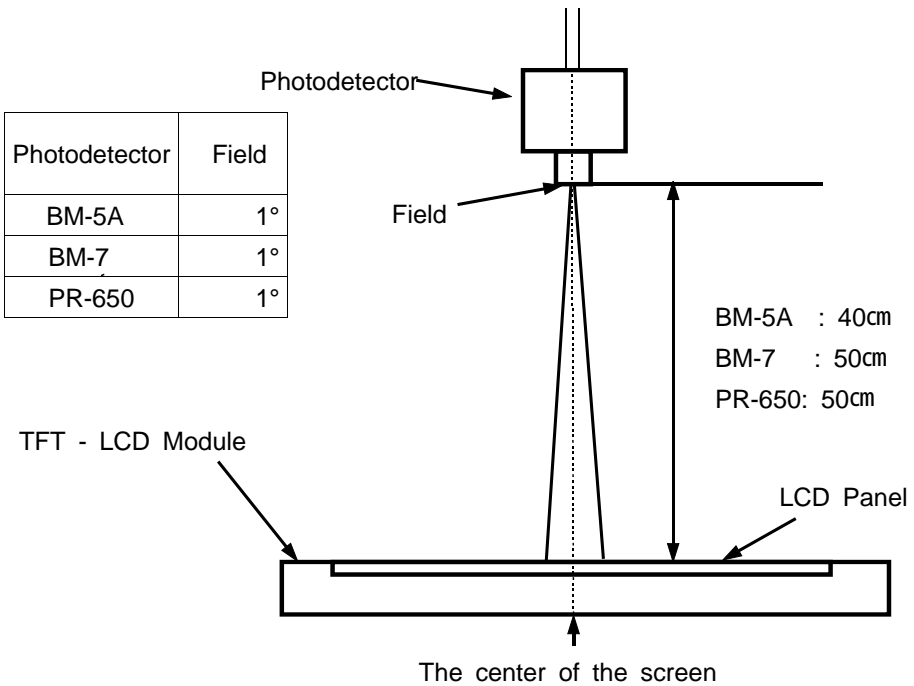

Back-Light Off condition

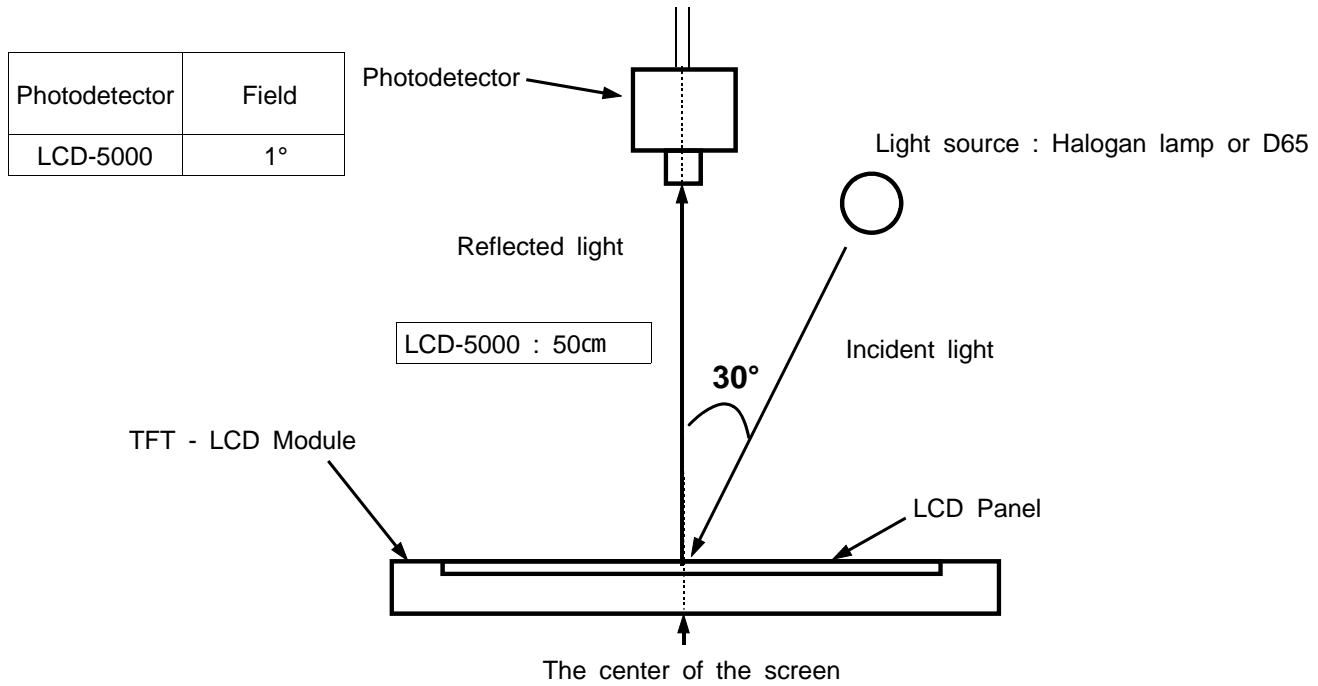

Optical Measuring Equipment Setup

Note (2) Definition of Contrast Ratio (C/R) : Ratio of gray max (Gmax) & gray min (Gmin) at the center point

$$CR = \frac{G \text{ max}}{G \text{ min}}$$

* Gmax : Luminance with all pixels white

* Gmin : Luminance with all pixels black

Note (3) Definition of Luminance of White : Luminance of white at the center point

Note (4) Definition of Response time : Sum of T_r , T_f

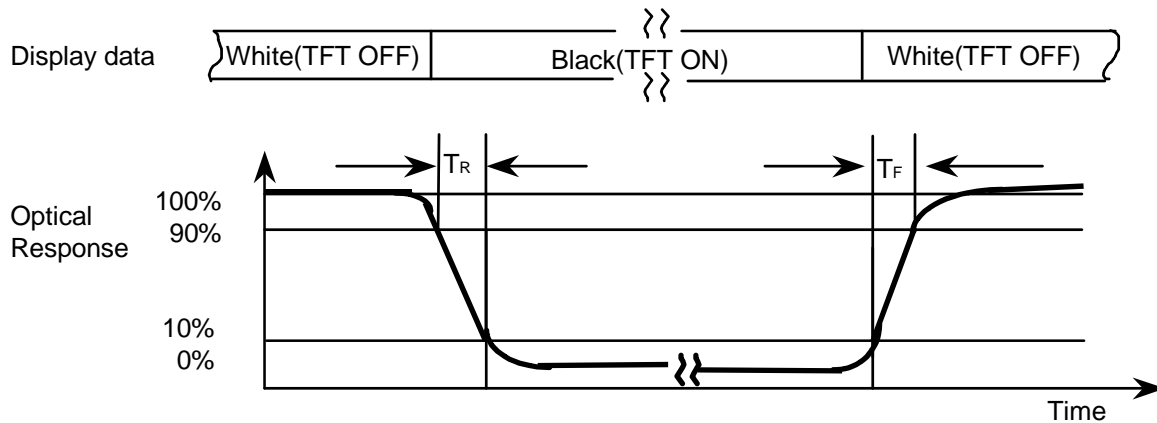

Note (5) Definition of Color Chromaticity (CIE 1931)

Color coordinate of white & red, green, blue at center point.

Note (6) Definition of Viewing Angle : Viewing angle range (CR 10)

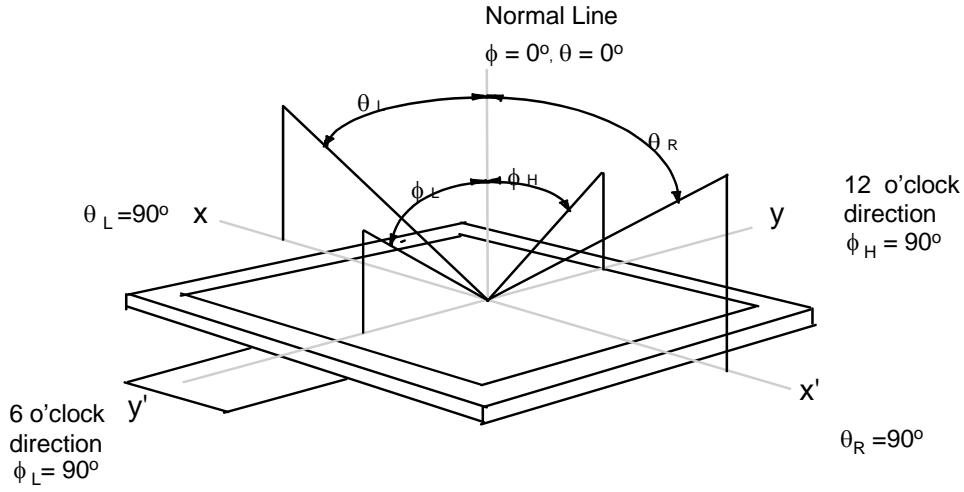

3. Electrical Characteristics

3.1 TFT-LCD Module

 $T_a = 25 \pm 2^\circ\text{C}$

Characteristics		Symbol	Min.	Typ.	Max.	Unit	Note
Digital supply voltage		V_{CC}	2.5	3.3	3.6	V	-
Analog supply voltage		DDVDH	4.8	4.9	5.0	V	-
Gate On voltage		V_{GH}	17.0	18.0	19.0	V	#1
Gate Off voltage		V_{GL}	-11	-10	-9	V	-
Vcom High voltage		VcomH		3.68			
Vcom Low voltage		VcomL		0.4			
Power Dissipation	Full	P_{FULL}		40	60	mW	#2,#3
Frame frequency		f_{Frame}	60	75	90	Hz	-
Dot Clock		DOTCLK	-	-	30.0	MHz	-
Serial Clock		SCL	-	-	16.0	MHz	-

Note #1. $V_{GH} - (V_{GL} \times 0.7) = 25V$

Note #2. $V_{CC} = 3.3V$, $f_{Frame} = 75Hz$, DOTCLK = 7.0MHz

Note #3. Dissipation current check pattern

0 Gray black pattern

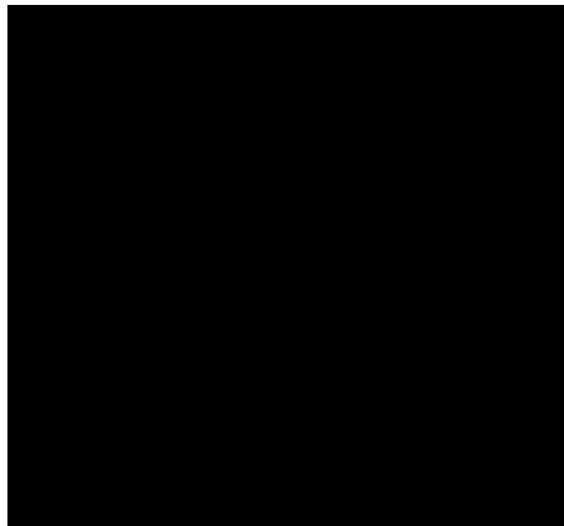

3.2 Back-Light unit

The back-light system is an edge-lighting type with **six** white LED(Light Emitting Diode)s.

(Ta=25 ± 2°C)

Item	Symbol	Min.	Typ.	Max.	Unit	Note
Current	I_B	-	20	-	mA	(1)
Power Consumption	P_{BL}	-	400	460	mW	(2)

Note (1) **Six** LEDs serial type.

(2) Where $I_B = 20\text{mA}$, $V_B = P_{BL} / I_B$

■ Ambient Temperature vs. Allowable Forward Current

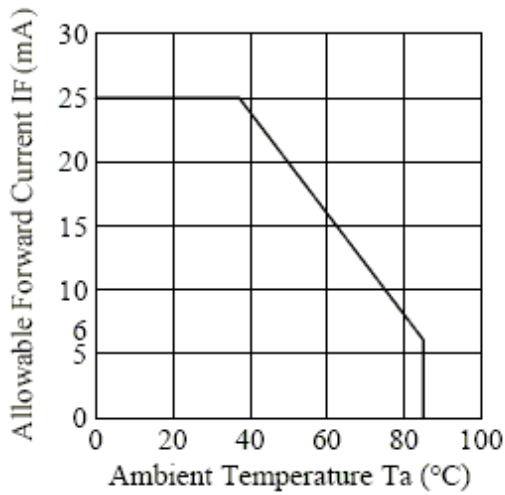

4. Touch Screen Panel Specifications

4-1. Electrical Characteristics

Item	Min.	Typ.	Max.	Unit	Note
Linearity	-1.5	-	1.5	%	Analog X and Y directions
Terminal resistance	100	-	-	Ω	X(Film side)
	100	-	-	Ω	Y(Film side)
Insulation resistance	25	-	-	M Ω	DC 25V
Voltage	-	-	7	V	DC
Chattering	-	-	10	ms	100k pull-up
Transparency	-	80	-	%	Non-glare

Caution (1) : Do not operate it with a thing except a polyacetal pen(tip R0.8mm or less) or a finger, especially those with hard or sharp tips such as a ball point pen or a mechanical pencil.

4-2. Mechanical & Reliability Characteristics

Item	Min.	Typ.	Max.	Unit	Note
Activation force	-		80	g	(1)
Durability-surface scratching	Write 100,000	-	-	characters	(2)
Durability-surface pitting	1,000,000	-	-	touches	(3)
Surface hardness	3	-	-	H	JIS K5400, ASTM D3363

Note (1) Stylus pen Input : R0.8mm polyacetal pen or Finger

(2) Measurement for Surface area

- Scratch 100,000 times straight line on the Film with a stylus change every 20,000times
- Force : 250gf
- Speed : 60mm/sec
- Stylus : R0.8 polyacetal tip

(3) Pit 1,000,000 times on the Film with a R8.0 silicon rubber.

- Force : 250gf
- Speed : 2times/sec

5. Block Diagram

5.1 TFT-LCD Module (Interface System Structure) with Back Light Unit

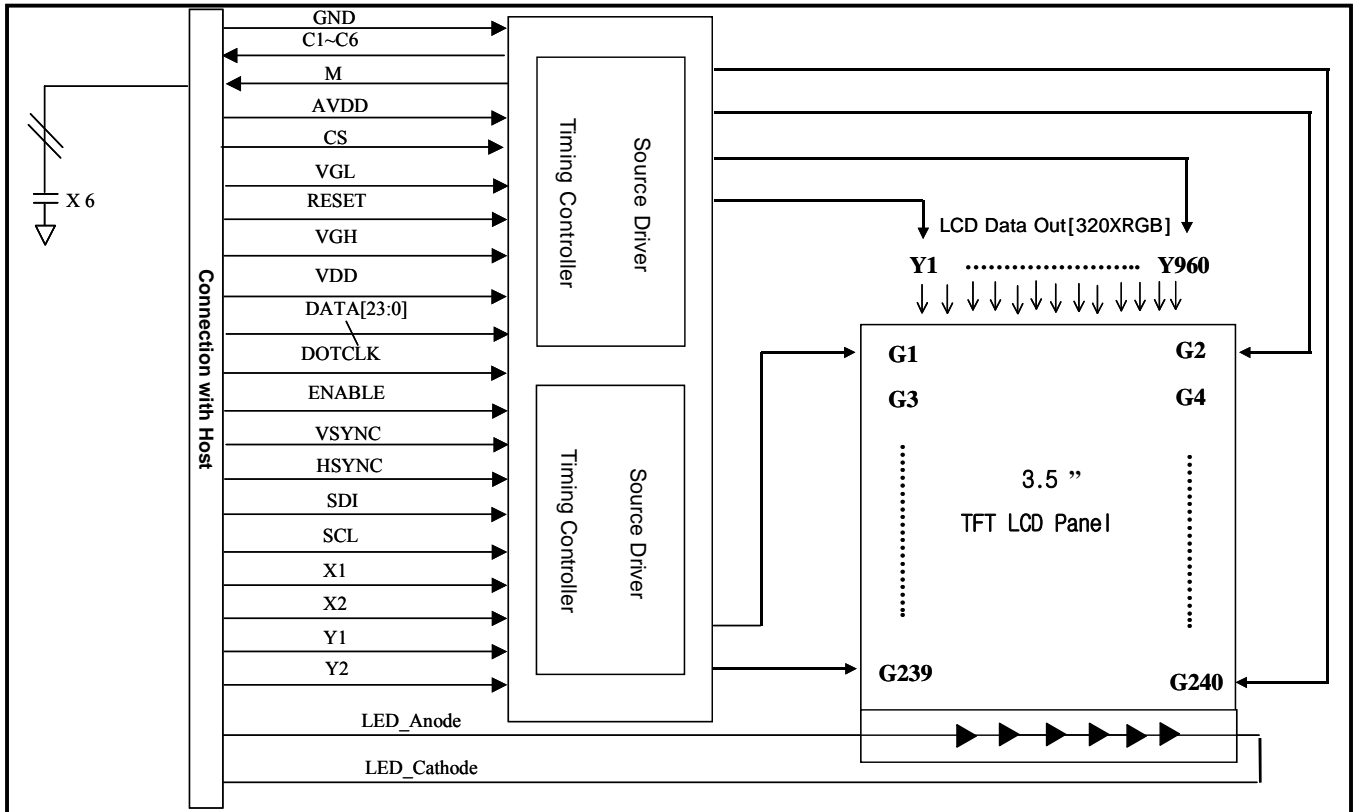

5.2 Touch Screen Panel

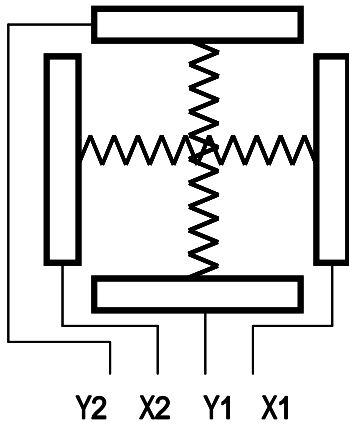

Top View

X : Upper electrode
Y : Lower electrode

5.3 Back-light Unit

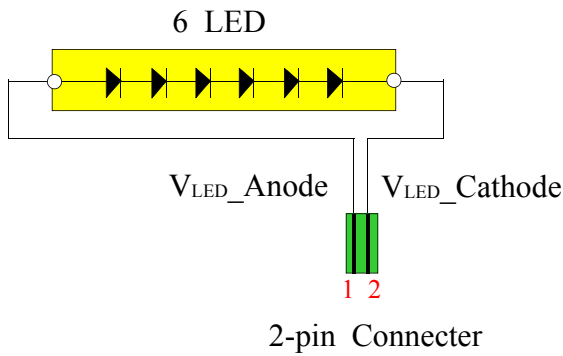

Pin No.	Symbol	I/O
1	LED_ANODE	Anode
2	LED_CATHODE	Cathode

6. Input Terminal Pin Assignment

6.1 Input Signal & Power (Connector type : 60Pin / 0.5mm pitch / Bottom contact)

- JAE : FF0360SA1

No	Symbol	Description	I/O	No	Symbol	Description	I/O
1,2	LED_Cathode	LED_Cathode	I	30	DATA12	Green Data	I
3,4	LED_Anode	LED_Anode	I	31	DATA13	Green Data	I
5	GND	Ground	I	32	DATA14	Green Data	I
6	X1	X_Right	I	33	DATA15	Green Data(MSB)	I
7	Y1	Y_Bottom	I	34	DATA16	Red Data (LSB)	I
8	X2	X_Left	I	35	DATA17	Red Data	I
9	Y2	Y_Up	I	36	DATA18	Red Data	I
10	GND	Ground	I	37	DATA19	Red Data	I
11	C6	Stable Capacitor connection	O	38	DATA20	Red Data	I
12	C5	Stable Capacitor connection	O	39	DATA21	Red Data	I
13	M	The signal to generate Vcom	O	40	DATA22	Red Data	I
14	RESET	Reset	I	41	DATA23	Red Data(MSB)	I
15	CS	Chip Select	I	42	HSYNC	Horizontal Synchronous Signal	I
16	SCL	Serial Clock	I	43	VSYNC	Vertical Synchronous Signal	I
17	SDI	Serial Data	I	44	DOTCLK	Data Colck	I
18	DATA0	Blue Data (LSB)	I	45,46	AVDD	Vanalog	I
19	DATA1	Blue Data	I	47,48	VDD	Vdigital	I
20	DATA2	Blue Data	I	49	C4	Stable Capacitor connection	O
21	DATA3	Blue Data	I	50,51	VGL	Vgoff Voltage	I
22	DATA4	Blue Data	I	52	C3	Stable Capacitor connection	O
23	DATA5	Blue Data	I	53	VGH	Vgon Voltage	I
24	DATA6	Blue Data	I	54	C2	Stable Capacitor connection	O
25	DATA7	Blue Data(MSB)	I	55	C1	Stable Capacitor connection	O
26	DATA8	Green Data(LSB)	I	56,57	VCOM	VCOM	I
27	DATA9	Green Data	I	58	ENABLE	Data enabling signal	I
28	DATA10	Green Data	I	59,60	GND	Ground	I
29	DATA11	Green Data	I				

Note (1) Connect Hsync, Vsync pin at Vcc or GND in DE mode.

(2) Connect ENABLE pin at Vcc or GND in SYNC mode.

6.2 Back-Light Unit (Connector : 2 pin FPC Solder type)

Pin No.	Symbol	Function
1	LED_ANODE	LED Anode
2	LED_CATHODE	LED Cathode

6.3 Touch Screen Panel (Connector : 4Pin FPC Solder type)

Pin No.	Symbol	I/O	Function
1	X1	Right	Right electrode - differential analog
2	Y1	Bottom	Bottom electrode - differential analog
3	X2	Left	Left electrode - differential analog
4	Y2	Top	Top electrode - differential analog

6.4 Input Signal, Basic Display Colors and Gray Scale of Each Colors

COLOR	DISPLAY	DATA SIGNAL																					GRAY SCALE LEVEL			
		RED							GREEN							BLUE										
		R0	R1	R2	R3	R4	R5	R6	R7	G0	G1	G2	G3	G4	G5	G6	G7	B0	B1	B2	B3	B4		B5	B6	B7
BASIC COLOR	BLACK	0	0	0	0	0	0	0	0	0	0	0	0	0	0	0	0	0	0	0	0	0	0	0	0	-
	BLUE	0	0	0	0	0	0	0	0	0	0	0	0	0	0	0	0	1	1	1	1	1	1	1	1	-
	GREEN	0	0	0	0	0	0	0	0	1	1	1	1	1	1	1	1	0	0	0	0	0	0	0	0	-
	CYAN	0	0	0	0	0	0	0	0	1	1	1	1	1	1	1	1	1	1	1	1	1	1	1	1	-
	RED	1	1	1	1	1	1	1	1	0	0	0	0	0	0	0	0	0	0	0	0	0	0	0	0	-
	MAGENTA	1	1	1	1	1	1	1	1	0	0	0	0	0	0	0	0	1	1	1	1	1	1	1	1	-
	YELLOW	1	1	1	1	1	1	1	1	1	1	1	1	1	1	1	1	0	0	0	0	0	0	0	0	-
	WHITE	1	1	1	1	1	1	1	1	1	1	1	1	1	1	1	1	1	1	1	1	1	1	1	1	-
GRAY SCALE OF RED	BLACK	0	0	0	0	0	0	0	0	0	0	0	0	0	0	0	0	0	0	0	0	0	0	0	R0	
	DARK	1	0	0	0	0	0	0	0	0	0	0	0	0	0	0	0	0	0	0	0	0	0	0	R1	
		0	1	0	0	0	0	0	0	0	0	0	0	0	0	0	0	0	0	0	0	0	0	0	R2	
		:	:	:	:	:	:	:	:	:	:	:	:	:	:	:	:	:	:	:	:	:	:	:	:	R3-R252
		:	:	:	:	:	:	:	:	:	:	:	:	:	:	:	:	:	:	:	:	:	:	:	:	
	LIGHT	1	0	1	1	1	1	1	1	0	0	0	0	0	0	0	0	0	0	0	0	0	0	0	R253	
		0	1	1	1	1	1	1	1	0	0	0	0	0	0	0	0	0	0	0	0	0	0	0	R254	
	RED	1	1	1	1	1	1	1	1	0	0	0	0	0	0	0	0	0	0	0	0	0	0	0	R255	
GRAY SCALE OF GREEN	BLACK	0	0	0	0	0	0	0	0	0	0	0	0	0	0	0	0	0	0	0	0	0	0	0	G0	
	DARK	0	0	0	0	0	0	0	0	1	0	0	0	0	0	0	0	0	0	0	0	0	0	0	G1	
		0	0	0	0	0	0	0	0	0	1	0	0	0	0	0	0	0	0	0	0	0	0	0	G2	
		:	:	:	:	:	:	:	:	:	:	:	:	:	:	:	:	:	:	:	:	:	:	:	G3-G252	
		:	:	:	:	:	:	:	:	:	:	:	:	:	:	:	:	:	:	:	:	:	:	:		
	LIGHT	0	0	0	0	0	0	0	0	1	0	1	1	1	1	1	1	0	0	0	0	0	0	0	G253	
		0	0	0	0	0	0	0	0	0	1	1	1	1	1	1	1	0	0	0	0	0	0	0	G254	
	GREEN	0	0	0	0	0	0	0	0	1	1	1	1	1	1	1	1	0	0	0	0	0	0	0	G255	
GRAY SCALE OF BLUE	BLACK	0	0	0	0	0	0	0	0	0	0	0	0	0	0	0	0	0	0	0	0	0	0	0	B0	
	DARK	0	0	0	0	0	0	0	0	0	0	0	0	0	0	0	0	1	0	0	0	0	0	0	B1	
		0	0	0	0	0	0	0	0	0	0	0	0	0	0	0	0	0	1	0	0	0	0	0	B2	
		:	:	:	:	:	:	:	:	:	:	:	:	:	:	:	:	:	:	:	:	:	:	:	B3-B252	
		:	:	:	:	:	:	:	:	:	:	:	:	:	:	:	:	:	:	:	:	:	:	:		
	LIGHT	0	0	0	0	0	0	0	0	0	0	0	0	0	0	0	0	1	0	1	1	1	1	1	B253	
		0	0	0	0	0	0	0	0	0	0	0	0	0	0	0	0	0	1	1	1	1	1	1	B254	
	BLUE	0	0	0	0	0	0	0	0	0	0	0	0	0	0	0	0	1	1	1	1	1	1	1	B255	

Note) Definition of Gray :

Rn : Red Gray, Gn : Green Gray, Bn : Blue Gray (n = Gray level)

Input Signal : 0 = Low level voltage, 1 = High level voltage

7. Operation Specifications

7.1 Serial Peripheral Interface

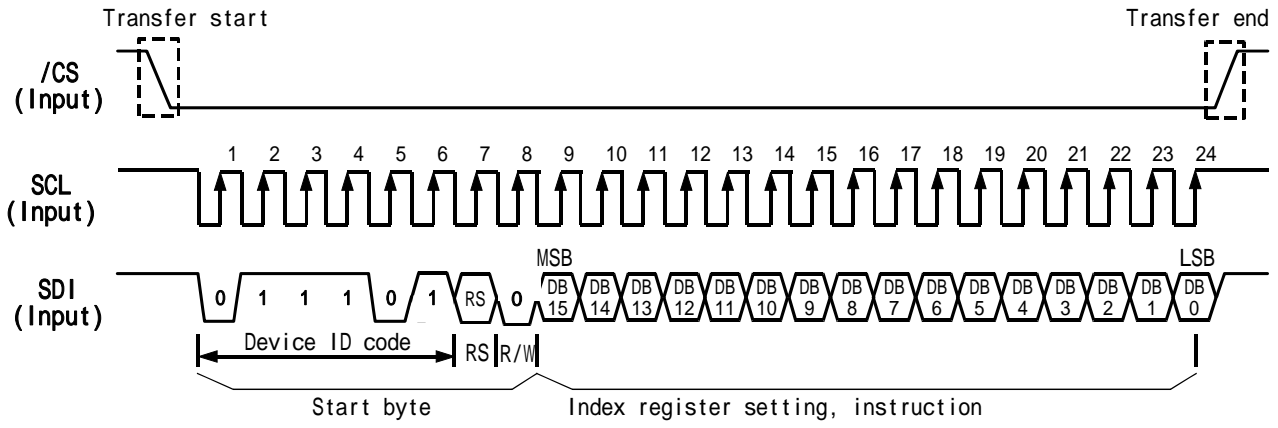

(Note) RS="0": Index data
 RS="1": Instruction data

7.2 Data Format for 24bit RGB Interface

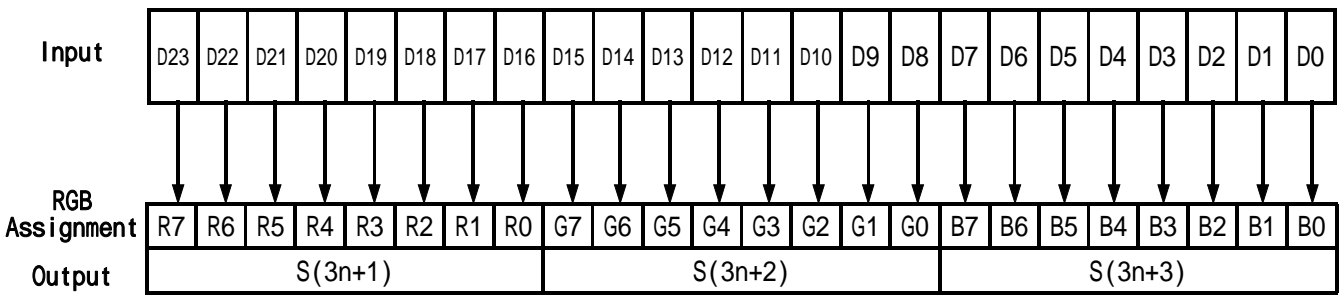

7.3 24bit RGB Interface Timing

a. SYNC mode

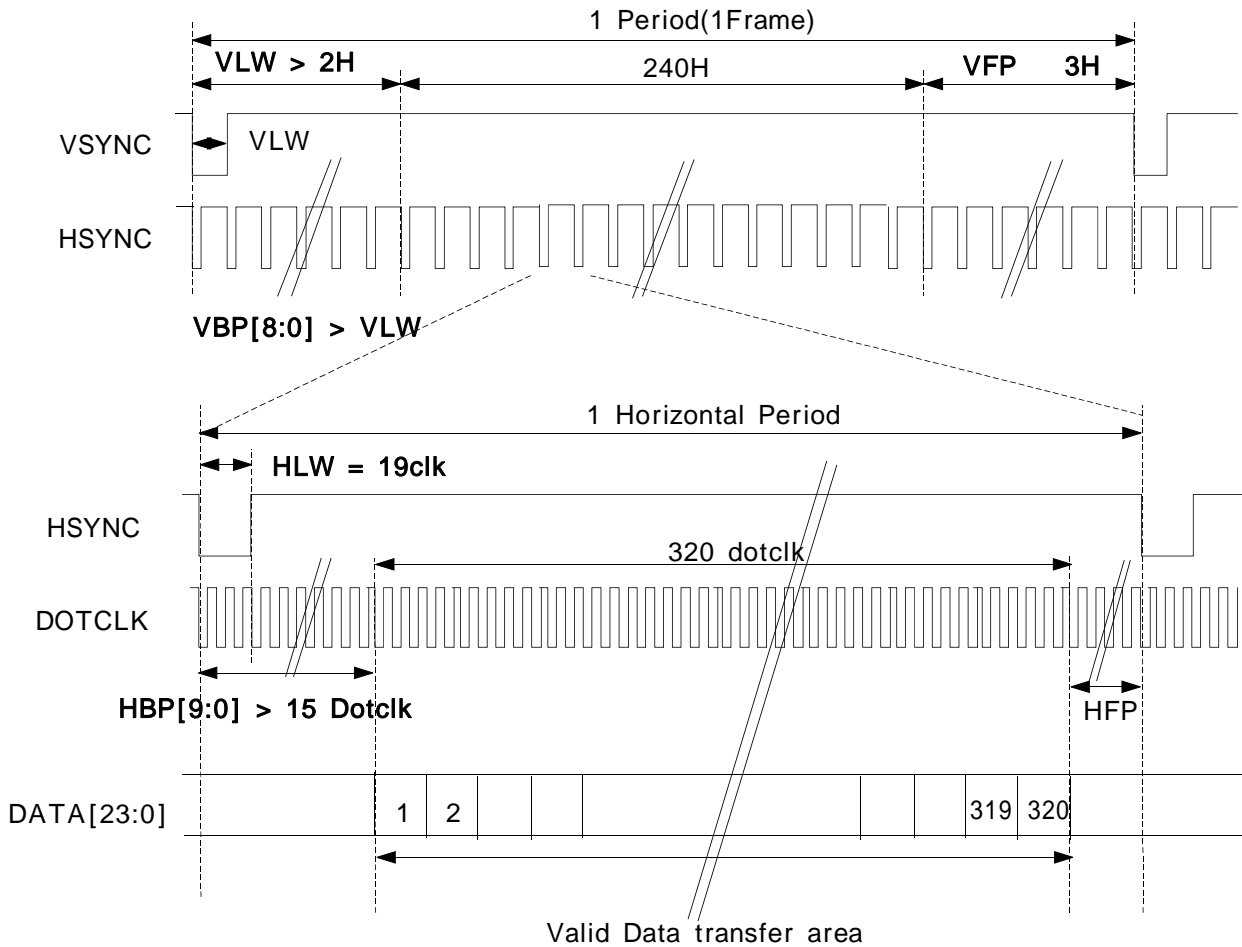

$$* \text{DOTCLK} = f_{\text{frame}} \times (240 + \text{VBP} + \text{VFP}) \times (320 + \text{HBP} + \text{HFP})$$

$$= 75\text{Hz} \times (240 + \text{VBP} + \text{VFP}) \times (320 + \text{HBP} + \text{HFP})$$

- * **3H VFP**
- * **HBP > HLW**
- * **VBP > VLW**
- * **15clk < HLW < 20clk**
- * **VLW > HLW**

- Note 1. Polarity register setting : VPL = 0, HPL = 0, DPL=0
 2. The rising edge of DOTCLK is used to fetch display data

b. DE mode

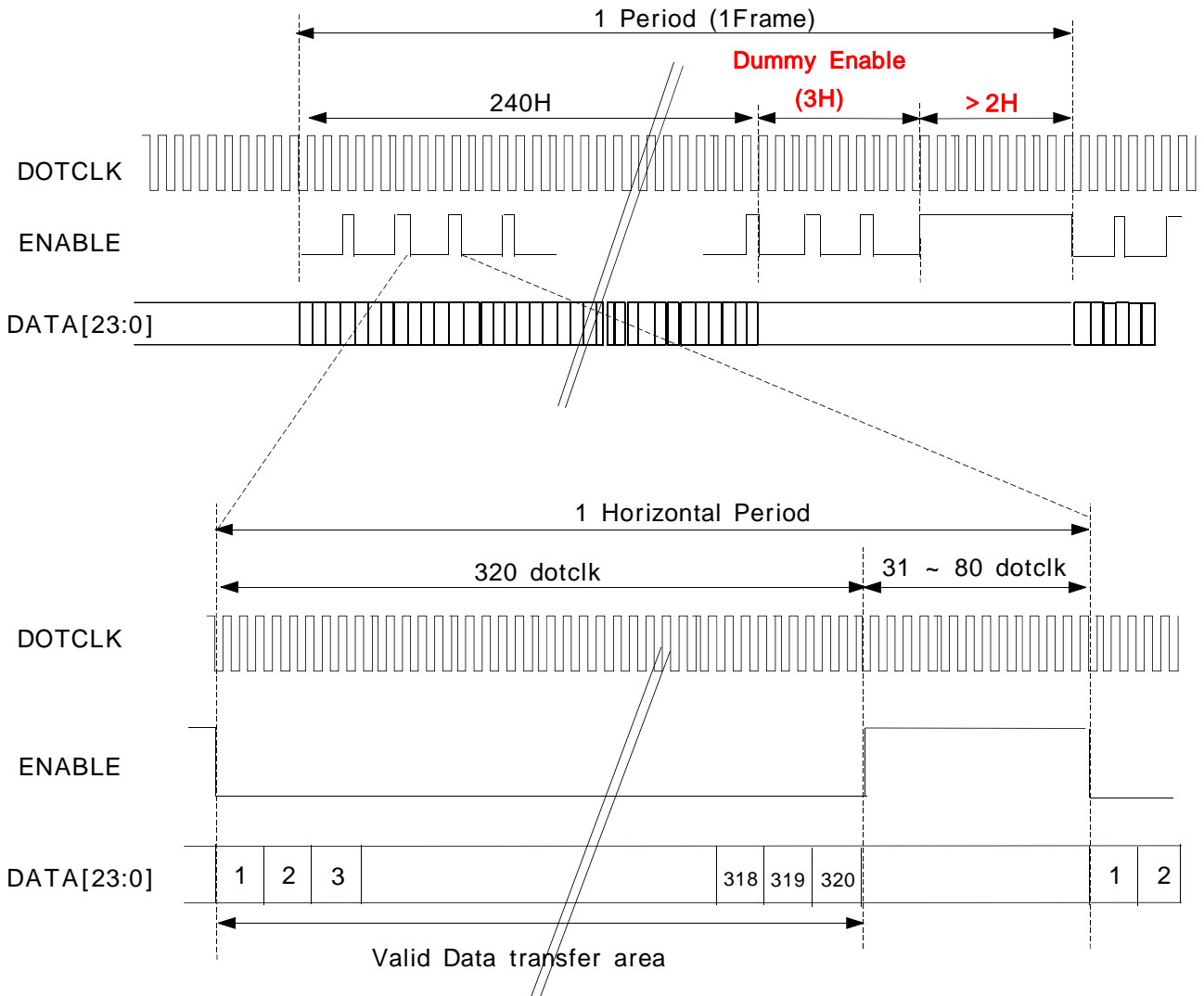

- Note 1. Polarity register setting : EPL = 0, DPL=0
- 2. The rising edge of DOTCLK is used to fetch display data

7.4 Electrical Specifications

a. RGB Data Interface Characteristics

(T_A = -40 to +85°C)

Characteristic	Symbol	24bit RGB Interface		Unit
		Min	Max	
DOTCLK cycle time	tDCYC	100	-	ns
DOTCLK rise/fall time	tR,tF	-	2	
DOTCLK Pulse width high	tDCHW	50	-	
DOTCLK Pulse width low	tDCLW	50	-	
SYNC setup time	tSYS	30	-	
SYNC hold time	tSYH	30	-	
ENABLE setup time	tENS	30	-	
ENABLE hold time	tENH	30	-	
PD data setup time	tPDS	30	-	
PD data hold time	tPDH	30	-	

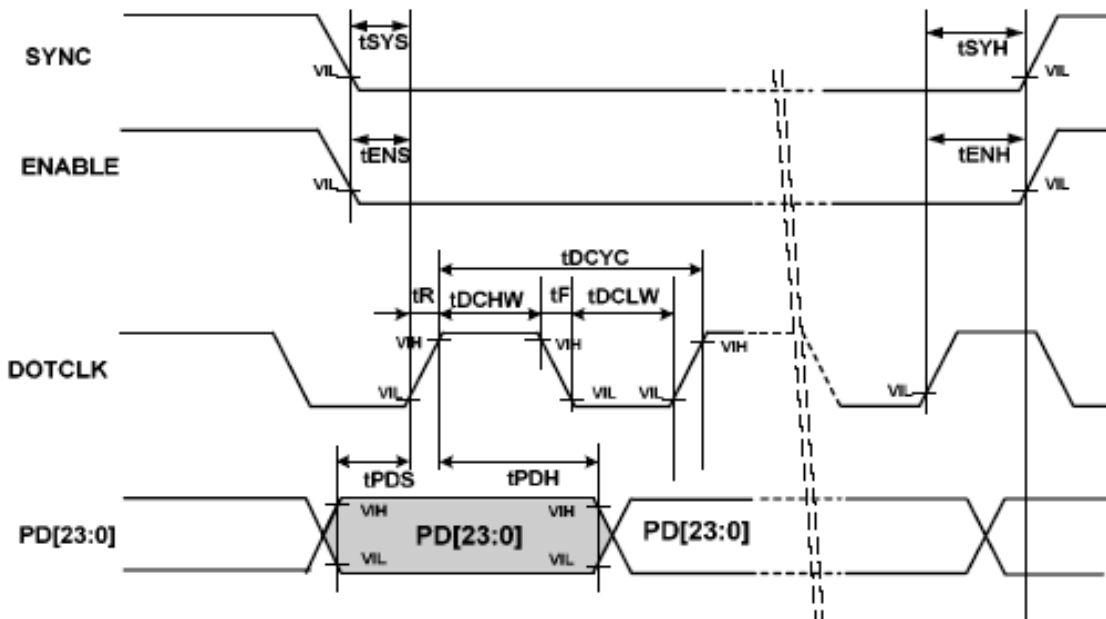

AC Characteristics

b. Clock Synchronized Serial Mode Characteristics

(T_A = -40 to +85°C)

Characteristic	Symbol	Min	Max	Unit
Serial clock cycle time	tscyc	100	-	ns
Serial clock rise/fall time	tR,tF	-	2	
Pulse width high for write	tSCHW	30	-	
Pulse width high for read	tSCHR	50	-	
Pulse width low for write	tSCLW	30	-	
Pulse width low for read	tSCLR	50	-	
Chip Select setup time	tCSS	20	-	
Chip Select hold time	tCSH	50	-	
Serial input data setup time	tSIDS	30	-	
Serial input data hold time	tSIDH	30	-	
Serial output data delay time	tSODD	-	100	
Serial output data hold time	tSODH	5	-	

c. Reset Timing Characteristics

(T_A = -40 to +85°C)

Characteristic	Symbol	Min	Max	Unit
Reset low pulse width	tRES	3*	-	us

*NOTE. Reset low pulse width shorter than 1us do not make reset. It means undesired short pulse such as glitch, bouncing noise or electorstatic discharge do not cause irregular system reset. Please refer to the table below.

tRES Pulse	Action
Shorter than 1 us	No reset
Longer than 3 us	Reset
Between 1 us and 3 us	Not determined

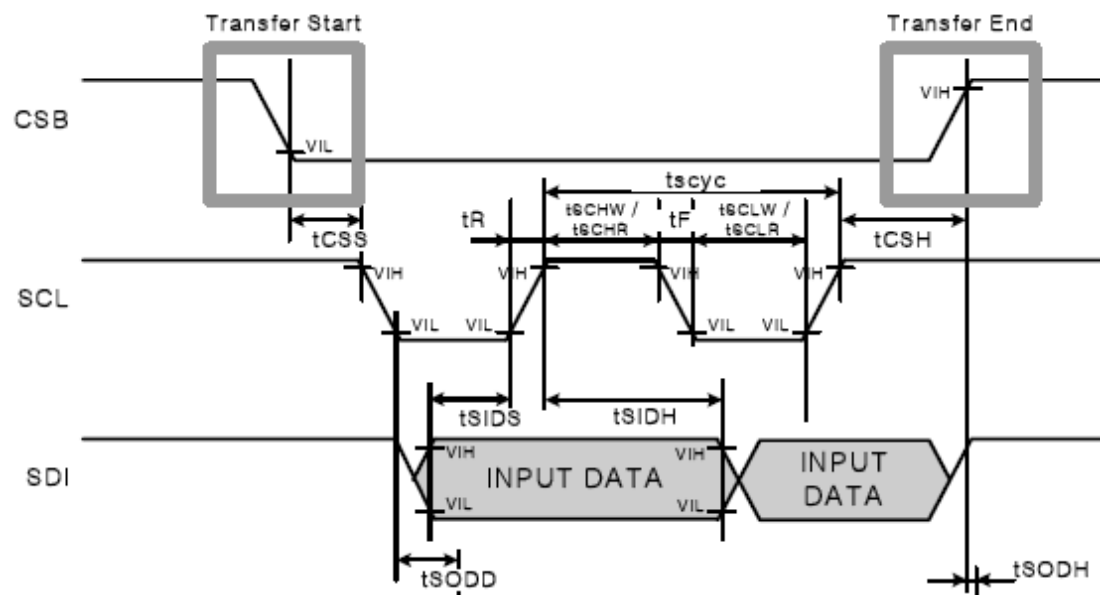

AC Characteristics(SPI Mode)

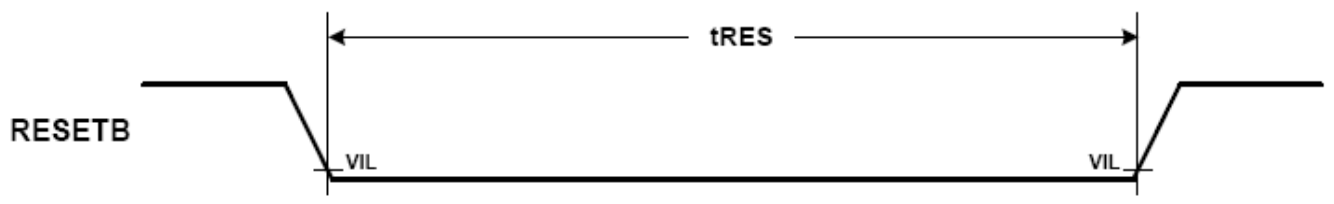

AC Characteristics(RESET timing)

8. Command List & Instruction Descriptions

8.1 Command List

Refer to the Appendix 1: S6F2002 IC Specification

8.2 Instruction Descriptions

Refer to the Appendix 1: S6F2002 IC Specification

9. Power On/Off Sequence

The power on/off sequence should be as the below.

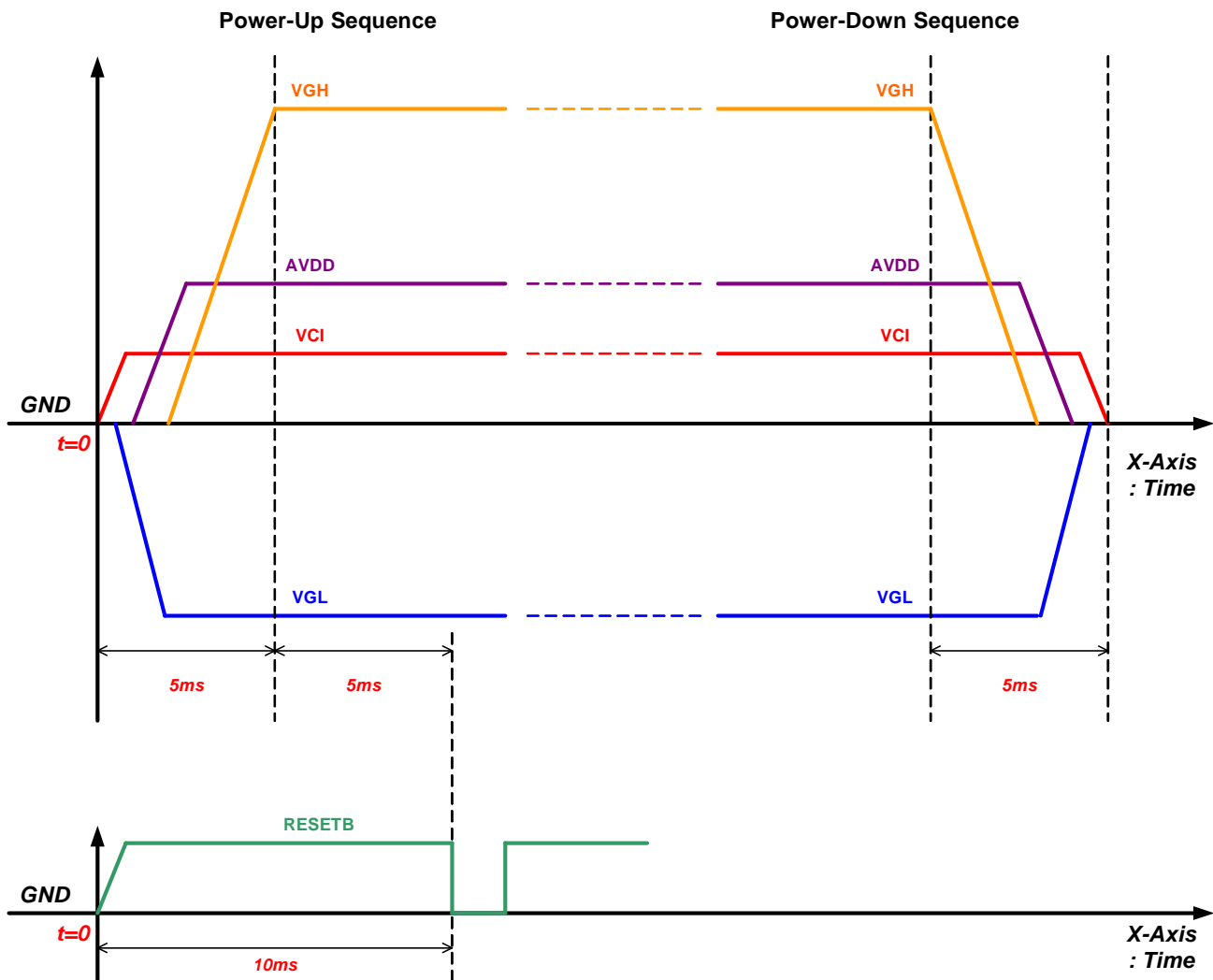

Note 1. VCI, AVDD, VGH and VGL could be turned on/off at the same time within the designated period (5ms)

Note 2. RESETB timing should be observed for the stable operation of the driver.

Note 3. During the Screen save mode or the Power save mode or the Sleep mode, all of the power to the LCD Module should not be supplied.

The Power on/off sequence should be same as the described above while mode is changed to prevent damage of the LCD Panel.

9.1 Power On Sequence

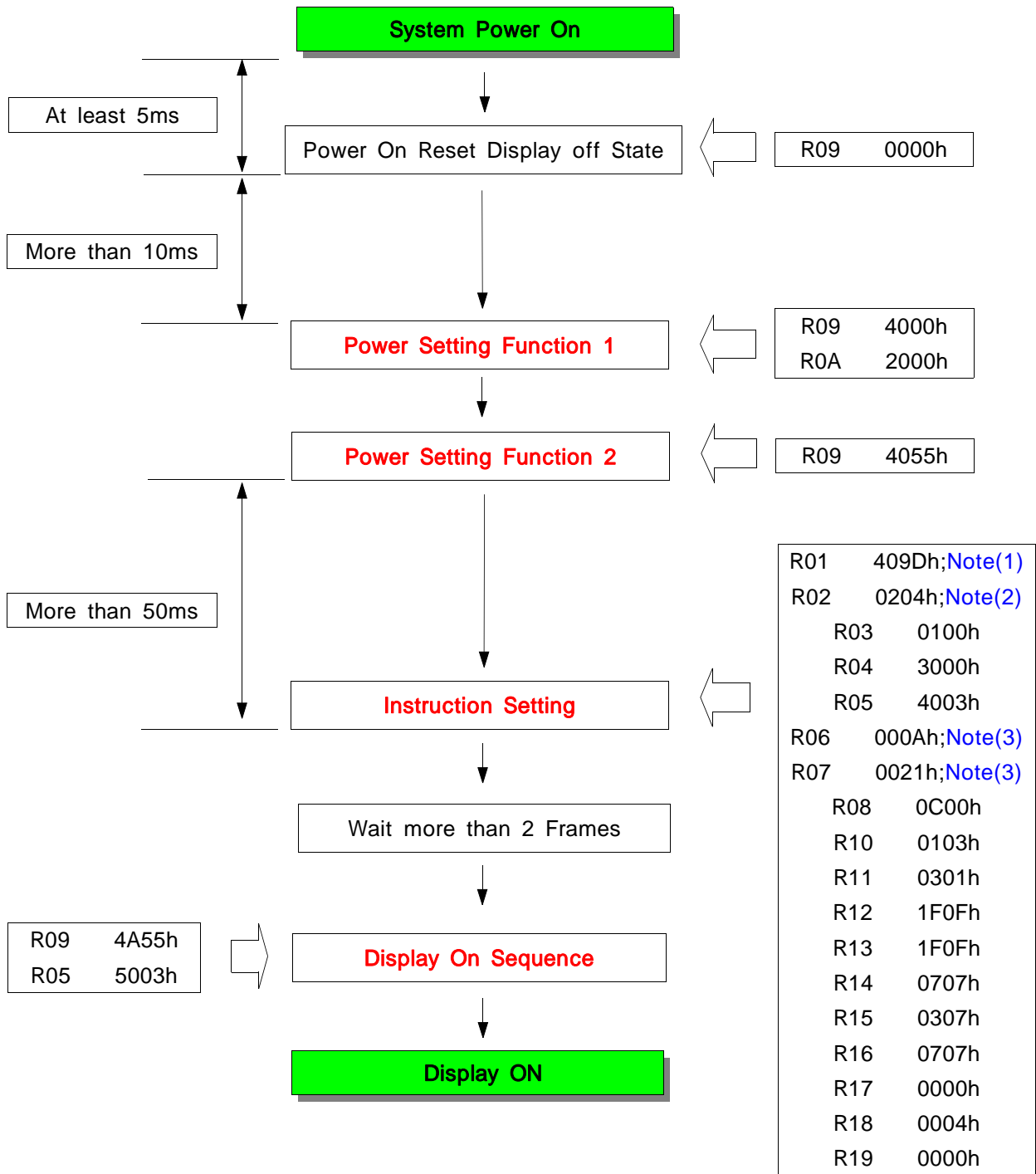

< Note (1) >

- Register 'R01' determine specify the interface mode

(R01H)

IB15	IB14	IB13	IB12	IB11	IB10	IB9	IB8	IB7	IB6	IB5	IB4	IB3	IB2	IB1	IB0
0	1	SSMD	0	0	0	0	0	1	0	0	1	1	1	0	1

- SSMD Bits Setting

SSMD	Interface	R01H
0	SYNC mode	409D
1	DE mode	609D

< Note (2) >

- Register 'R02' determines Data format

(R02H)

IB15	IB14	IB13	IB12	IB11	IB10	IB9	IB8	IB7	IB6	IB5	IB4	IB3	IB2	IB1	IB0
0	0	0	0	0	0	1	0	DF1	DF0	0	0	0	1	0	0

- DF Bits Setting

DF1	DF0	Data Format	R02H
0	0	RGB RGB	0204
0	1	RGBX RGBX	0244
1	0	XRGB XRGB	0284
1	1	Setting Inhibited	

- Register 'R06', 'R07' determine Vsync Backporch('R06') & Hsync Backporch period('R07')

- Backporch limit

(1) 7clk < Hsync Backporch < 1024clk

(2) 3line < Vsync Backporch < 512line

(R06H)

IB15	IB14	IB13	IB12	IB11	IB10	IB9	IB8	IB7	IB6	IB5	IB4	IB3	IB2	IB1	IB0
0	0	0	0	0	0	0	VBP8	VBP7	VBP6	VBP5	VBP4	VBP3	VBP2	VBP1	VBP0

(R07H)

IB15	IB14	IB13	IB12	IB11	IB10	IB9	IB8	IB7	IB6	IB5	IB4	IB3	IB2	IB1	IB0
0	0	0	0	0	0	0	HBP8	HBP7	HBP6	HBP5	HBP4	HBP3	HBP2	HBP1	HBP0

9.2 Power Off Sequence

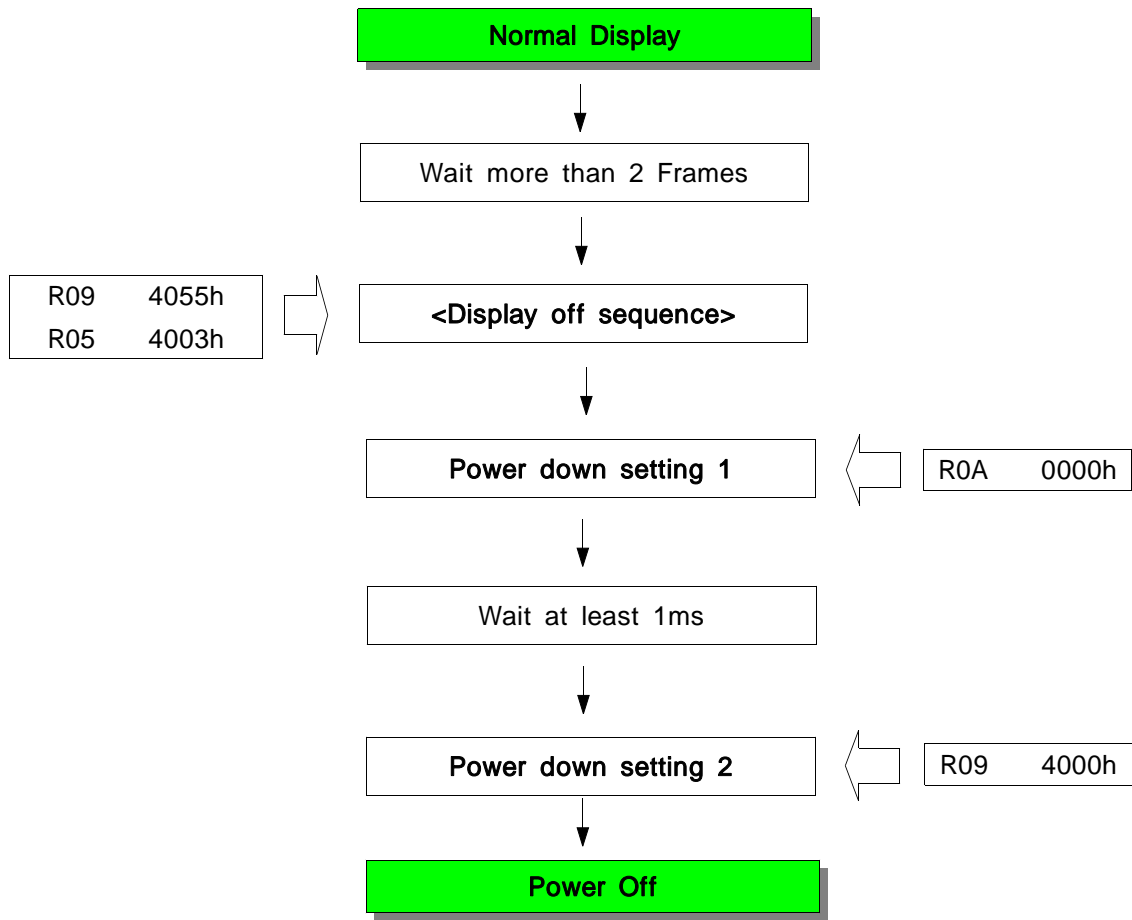

10. Reliability Test Result

Item	Condition	Sample Size	Test Result
High Temperature Operating Life test	60℃ 240HR	10EA	pass
Low Temperature Operating Life test	-20℃ 240HR	5EA	pass
Thermal Humidity Bias	50℃ 90%RH 240HR	10EA	pass
On/Off specificity	70℃ ↔ -30℃ (5CYC) On/Off 18,000 times more	10EA	pass
High Temperature Storage test	70℃ 240HR	5EA	pass
Low Temperature Storage test	-30℃ 240HR	5EA	pass
Wet Humidity Temperature Storage test	60℃ 90%RH 240HR	10EA	pass
Temperature Characteristics	-25℃ ~ 70℃ 100CYC	10EA	pass
Non-Operating Altitude test	115mb/Normal Temperature 72HR	5EA	pass
Electrical Static Discharge CDM	Air : ±8kV, 150pF/330Ω	5EA, 20time/point	pass
	Contact : ±4kV, 150pF/330Ω	5EA, 20time/point	pass
Box Vibration	Random Vibration MIL-STD 810E, Z-axis	1 Box (small)	pass
Box Drop	~9.1kg : 76cm, 9.2~18.2kg : 66cm	1 Box (medium)	pass

NO	PIN NAME
1	LED_Cathode
2	LED_Cathode
3	LED_Anode
4	LED_Anode
5	GND
6	X1
7	Y1
8	X2
9	Y2
10	GND
11	C6
12	C5
13	M
14	RESET
15	CS
16	SCL
17	SDI
18	DATA0
19	DATA1
20	DATA2
21	DATA3
22	DATA4
23	DATA5
24	DATA6
25	DATA7
26	DATA8
27	DATA9
28	DATA10
29	DATA11
30	DATA12
31	DATA13
32	DATA14
33	DATA15
34	DATA16
35	DATA17
36	DATA18
37	DATA19
38	DATA20
39	DATA21
40	DATA22
41	DATA23
42	HSYNC
43	VSYNC
44	DOTCLK
45	AVDD
46	AVDD
47	VDD
48	VDD
49	C4
50	VGL
51	VGL
52	C3
53	VGH
54	C2
55	C1
56	VCOM
57	VCOM
58	ENABLE
59	GND
60	GND

11.Outline Dimension

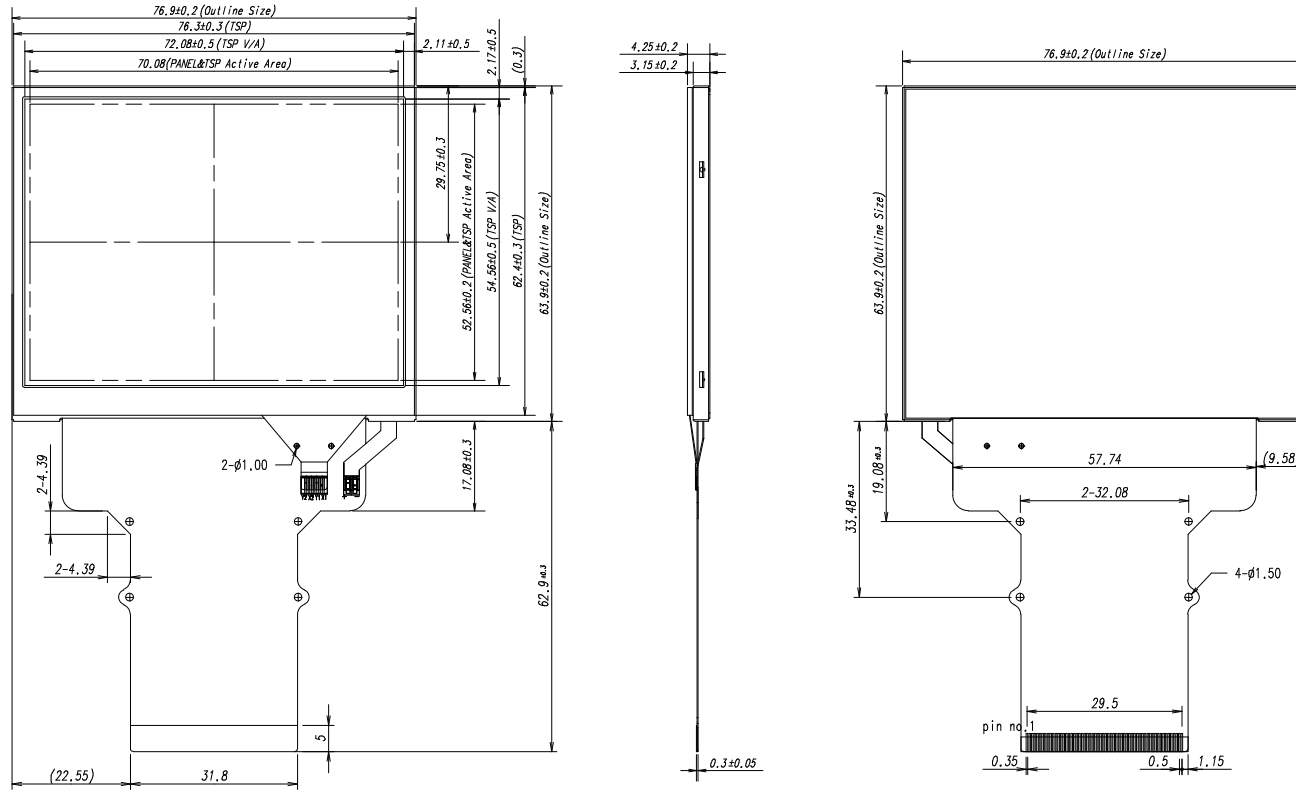

NO	PART NAME	CODE NO	SPECIFICATION	Q'TY	SPEC NO	REMARK
----	-----------	---------	---------------	------	---------	--------

GENERAL TOLERANCE				REV	DATE	DESCRIPTION OF REVISION			REASON		CHG'D BY		
STEP	LEVEL 1	LEVEL 2	LEVEL 3	UNIT	mm	DRA'N BY	DES'D BY	CHK'D BY	APP'D BY	MODEL NAME	LTV350QV-F05		
0 < X ≤ 4	±0.05	±0.1	±0.2	SCALE	1/1	W,H,KIM	S,H.LEE	Y,B,CHU		PART/SHEET NAME	Outline-Dimension		
4 < X ≤ 16	±0.08	±0.15	±0.3	TOLERANCE	LEVEL 2	05.05.19	05.05.19	05.05.19		SHEET	1/1		
16 < X ≤ 64	±0.12	±0.25	±0.5	SAMSUNG ELECTRONICS								CODE NO.	
64 < X ≤ 256	±0.25	±0.4	±0.8									SPEC. NO.	

12. Packing

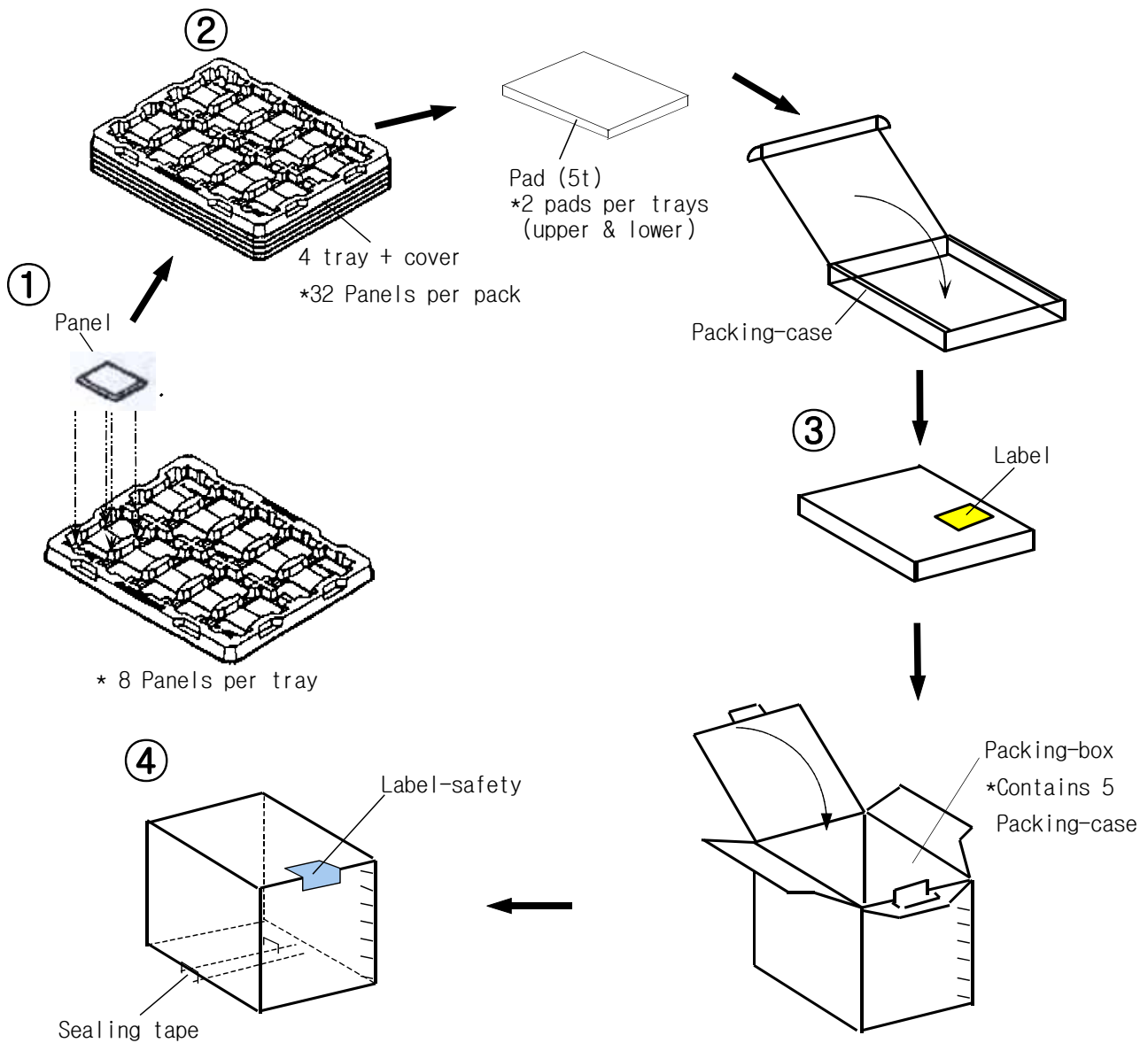

Note (1) Total : Case: Approx. 2.7 Kg

Box: Approx. 14.1 Kg

(2) Size : Case: 490(W) x 342(D) x 58(H)

Box: 505(W) x 355(D) x 312(H)

(3) Place the panels in the tray facing the direction shown in the figure.

(4) Place 4 tray and cover(empty tray) and pads inside the packing-case.

(5) Place 4 packing-case inside the packing-box.(Affix the label)

(6) Seal the packing-box. Affix the label-safety.

13. Marking & Others

(1) Packing case attach

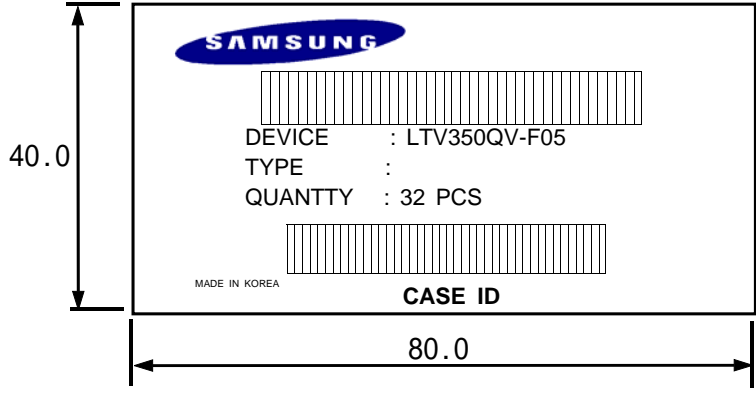

CASE ID : V 00 00 00001

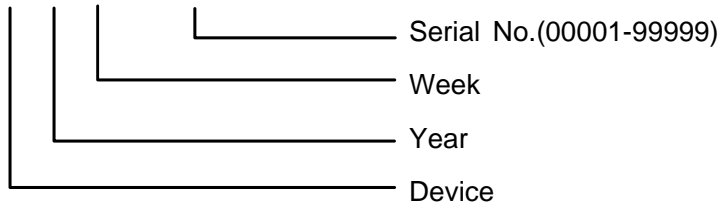

14. General Precautions

14.1 Handling

- (a) When the module is assembled, it should be attached to the system firmly. Be careful not to twist and bend the module.
- (b) Refrain from strong mechanical shock and / or any force to the module. In addition to damage, this may cause improper operation or damage to the module and back-light unit.
- (c) Note that polarizers are very fragile and could be easily damaged. Do not press or scratch the surface harder than a HB pencil lead.
- (d) Wipe off water droplets or oil immediately. If you leave the droplets for a long time, Staining and discoloration may occur.
- (e) If the surface of the polarizer is dirty, clean it using some absorbent cotton or soft cloth.
- (f) The desirable cleaners are water, IPA(Isopropyl Alcohol) or Hexane. Do not use Ketone type materials(ex. Acetone), Ethyl alcohol, Toluene, Ethyl acid or Methyl chloride. It might permanent damage to the polarizer due to chemical reaction.
- (g) If the liquid crystal material leaks from the panel, it should be kept away from the eyes or mouth. In case of contact with hands, legs or clothes, it must be washed away thoroughly with soap.
- (h) Protect the module from static , it may cause damage to the Integrated Gate Circuit.
- (i) Use finger-stalls with soft gloves in order to keep display clean during the incoming inspection and assembly process.
- (j) Do not disassemble the module.
- (k) Protection film for polarizer on the module shall be slowly peeled off just before use so that the electrostatic charge can be minimized.
- (l) Pins of I/F connector shall not be touched directly with bare hands

14.2 Storage

- (a) Do not leave the panel in high temperature, and high humidity for a long time. It is highly recommended to store the module with temperature from 0 to 35°C and relative humidity of less than 70%.
- (b) Do not store the TFT-LCD module in direct sunlight.
- (c) The module shall be stored in a dark place. It is prohibited to apply sunlight or fluorescent light during the store.

14.3 Operation

- (a) Do not connect, disconnect the module in the "Power On" condition.
- (b) Power supply should always be turned on/off by the "Power on/off sequence"

14.4 Others

- (a) The Liquid crystal is deteriorated by ultraviolet, do not leave it in direct sunlight and strong ultraviolet ray for many hours.
- (b) Avoid condensation of water. It may result in improper operation or disconnection of electrode.
- (c) Do not exceed the absolute maximum rating value. (the supply voltage variation, input voltage variation, variation in part contents and environmental temperature, and so on) Otherwise the panel may be damaged.
- (d) If the panel displays the same pattern continuously for a long period of time, it can be the situation when the image "Sticks" to the screen.
- (e) This panel has its circuitry FPC on the bottom side and should be handled carefully in order not to be stressed.
- (f) Avoid shortness between LED soldering pad and TSP soldering pad.