

mass integrated

global part distribution • product lifecycle partner
excess inventory management • value-ad service provider



Data sheet provided by Mass Integrated

massintegrated.com • displayalliance.com

Please call +1.978.465.6190
Email: sales@massintegrated.com



ISO 9001: 2008

Mass Integrated complies with all DMCA takedown notices. Please send a formal DMCA Takedown Notice to Mass Integrated Systems, Inc. • 18 Henry Graf Jr. Road, Unit 1 • Newburyport, MA 01950.

Product Specifications

Customer	
Description	5.0" TFT LCD Module
Model Name	LW500AC9001
Date	2008/06/20
Doc. No.	
Revision	05

Customer Approval	
Date	
The above signature represents that the product specifications, testing regulation, and warranty in the specifications are accepted	

Engineering			
Check	Date	Prepared	Date
		蔡儀珍	2008/06/20

Head Office & Factory : No. 12, Nanke 8th Rd., Tainan Science-Based Industrial Park, Taiwan, 74144 R.O.C.

TEL: +886-6-5889980

FAX: +886-6-5051522

Preliminary

CONTENTS

No.	ITEM	PAGE
0	RECORD OF REVISION	3
1	SUMMARY	4
2	FEATURES	4
3	GENERAL SPECIFICATIONS	4
4	ABSOLUTE MAXIMUM RATINGS	4
5	ELECTRICAL CHARACTERISTICS	5
6	DC CHARATERISTICS	6
7	AC CHARACTERISTICS	6~8
8	OPTICAL CHARATERISTIC	9~11
9	INTERFACE	12~13
10	BLOCK DIAGRAM	14
11	QUALITY ASSURANCE	15
12	OUTLINE DRAWING	16
13	PACKAGE INFORMATION	17
14	PRECAUTIONS	18~19

Preliminary

CHIHSIN CONFIDENTIAL FOR REVIEW ONLY

1. SUMMARY

LW500AC9001 is a transmissive type color active matrix liquid crystal display (LCD) which uses amorphous thin film transistor (TFT) as switching devices. This product is composed of a TFT LCD panel, driver ICs, FPC and a backlight unit. The following table described the features of LW500AC9001.

2. FEATURES

High Resolution: 1152,000 Dots (800 RGB x 480).
 Application: Portable Navigation
 PMP (Personal Multimedia Player), MP4 application product
 DVB-S
 GAMING

3. GENERAL SPECIFICATIONS

Parameter	Specifications	Unit
Screen Size	5.0(Diagonal)	inch
Display Format	800 RGB x 480	Dot
Active Area	108(H) x64.8(V)	mm
Pixel Pitch	0.135(H) x 0.135(V)	mm
Surface Treatment	Anti-glare	
Pixel Configuration	RGB-Stripe	
Outline Dimension	118.5(H) x 77.55 (V) x 3.4(T)	mm
Weight	65.92	g
View Angle Direction	6 o'clock	
Temperature Range	Operation	-20~70 °C
	Storage	-30~80 °C

4. ABSOLUTE MAXIMUM RATINGS

Item	Symbol	Values		Unit	Condition
		Min.	Max.		
Power Voltage	VCC	-0.3	+7.0	V	

Note: Device is subject to be damaged permanently if stresses beyond those absolute maximum ratings listed above.

Preliminary

5. ELECTRICAL CHARACTERISTICS

5.1. Operating conditions:

Item	Symbol	Values			Unit	Remark
		Min.	Typ.	Max.		
Power Supply	VCC	2.7	3.3	3.6	V	
Operating Current	IDD	-	110	-	mA	
Frame frequency	fFrame	-	60	-	Hz	
Dot Data Clock	DCLK	-	33.26	-	MHz	
Power Consumption	PLCD	-	363	-	mW	

5.2 LED driving conditions

Item	Symbol	Values			Unit	Remark
		Min.	Typ.	Max.		
Power Consumption	PLED	-	924	-	mW	
LED Current	If	-	40	-	mA	
Backlight Voltage	Vb	-	23.1	-	V	

Note 1 : Ta = 25°C

Note 2 : Brightness to be decreased to 50% of the initial value

6. DC CHARACTERISTICS

Parameter	Symbol	Rating			Unit	Condition
		Min.	Typ.	Max.		
Low level input voltage	V _{IL}	0	-	0.3* VCC	V	
Hight level input voltage	V _{IH}	0.7* VCC	-	VCC	V	

Preliminary

7. AC CHARACTERISTICS

7.1 AC Timing Characteristics

.Sync mode

Signal	Item	Symbol	Min	Typ	Max	Unit	Note
CLK	Frequency	F _{CPH}	-	33.26	-	MHZ	
	Period	T _{CPH}	-	30.06	-	ns	
	Pulse duty	T _{CWH}	40	50	60	%	
HS	Period	T _H	-	1056	-	T _{CPH}	
	Pulse width	T _{WH}	1	128	-	T _{CPH}	
	First horizontal data time	T _{HS}	STHD[7:0]+88			T _{CPH}	1
	Active Time	T _{HA}	-	800	-	T _{CPH}	
VS	Period	T _V	-	525	-	T _H	
	Pulse Width	T _{WV}	1	2	-	T _H	
	DEN time	T _{Vs}	STVD[7:0]+8			T _H	2
	Active Time	T _{VA}	-	480	-	T _H	
---	VS falling to HS falling time	T _{HV}	-4	-	4	T _{CPH}	Fig7.1

Note1: T_{HS}+ T_{HA}< T_H,STHD[7:0] Default = 128.

Note2: STVD[7:0] Default = 27.

.DEN mode

Signal	Item	Symbol	Min	Typ	Max	Unit	Note
CLK	Frequency	F _{CPH}	-	33.26	-	MHZ	
	Period	T _{CPH}	-	30.06	-	ns	
	Pulse duty	T _{CWH}	40	50	60	%	
DE	Period	T _{DEH} +T _{DEL}	1000	1056	1200	T _{CPH}	
	Pulse width	T _{DH}	-	800	-	T _{CPH}	
	Frame blanking	T _{HS}	10	45	110	T _{DEH} +T _{DEL}	
	Frame width	T _{EP}	-	480	-	T _{DEH} +T _{DEL}	

Preliminary

7.2 AC Timing Diagrams
.DEN mode

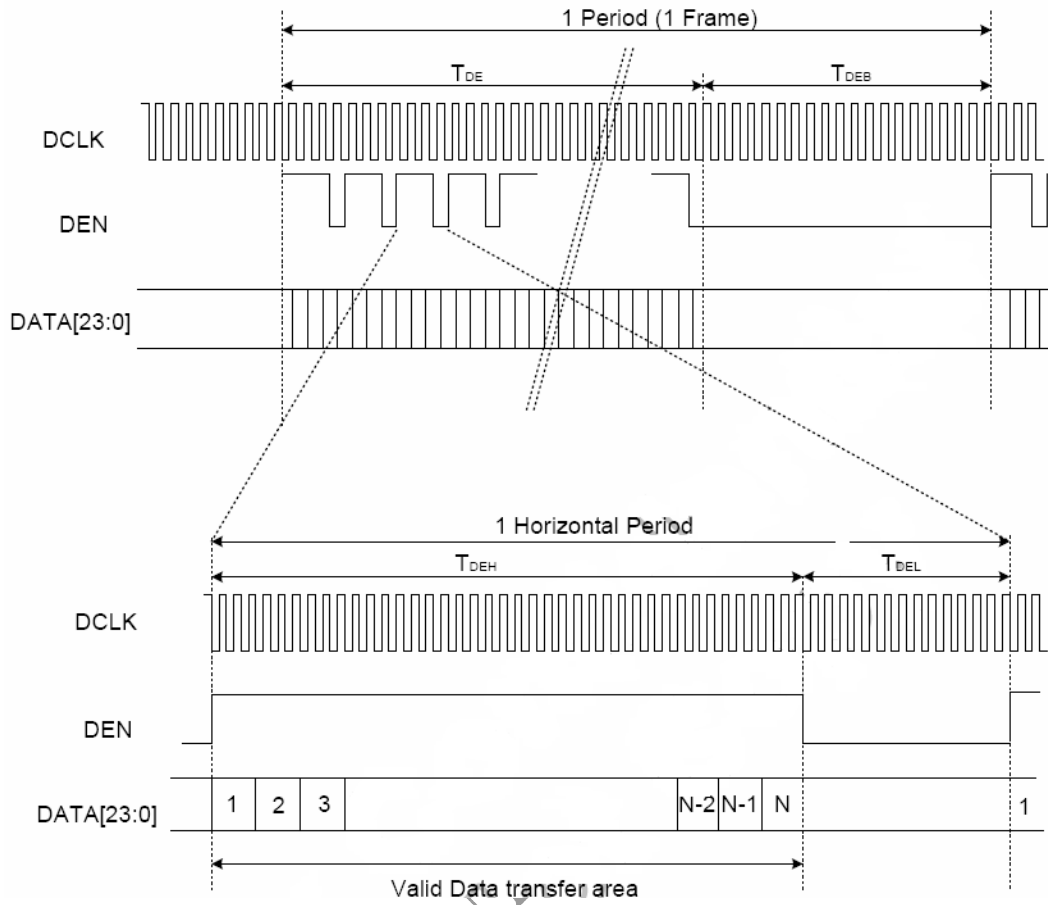

LY

Preliminary

.Sync mode

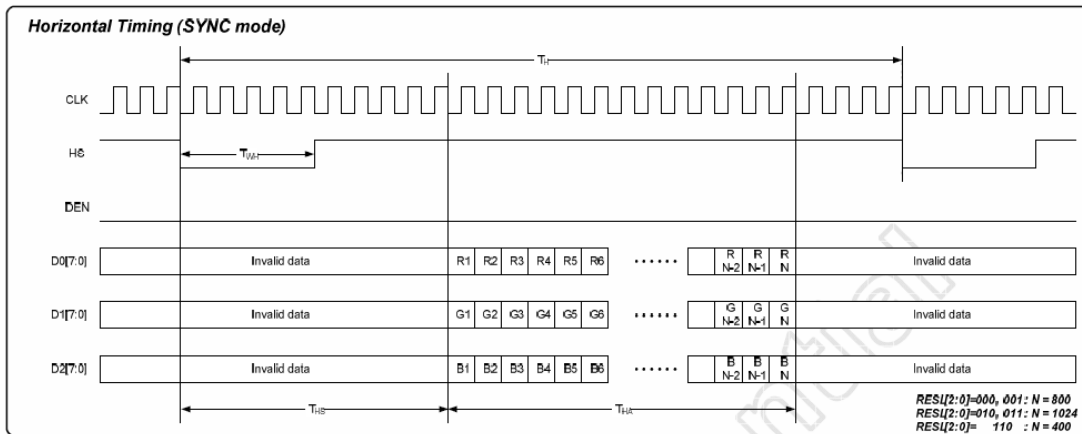

SYNC Mode Horizontal Data Format

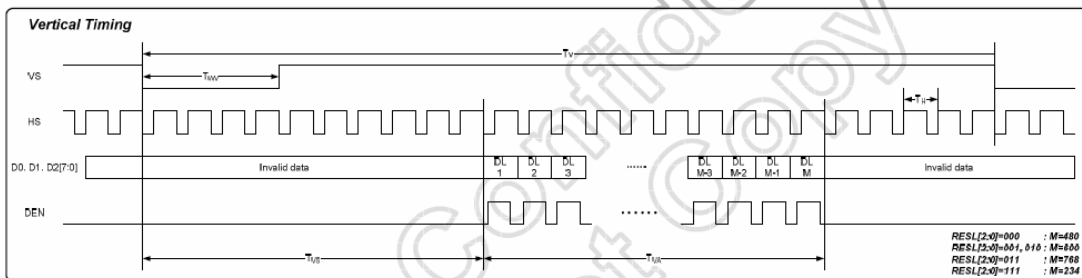

SYNC Mode Vertical Data Format

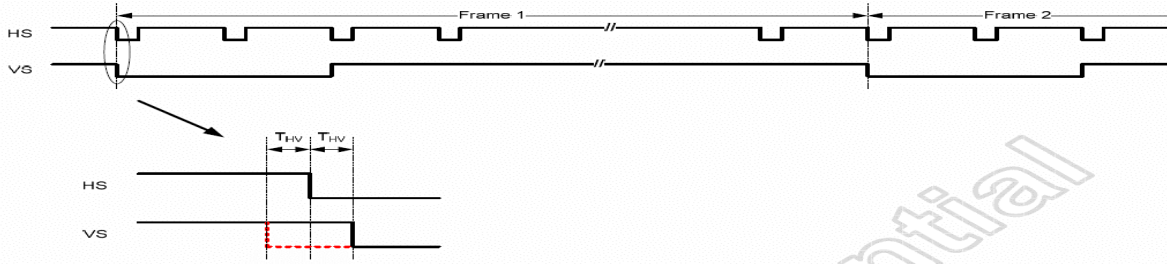
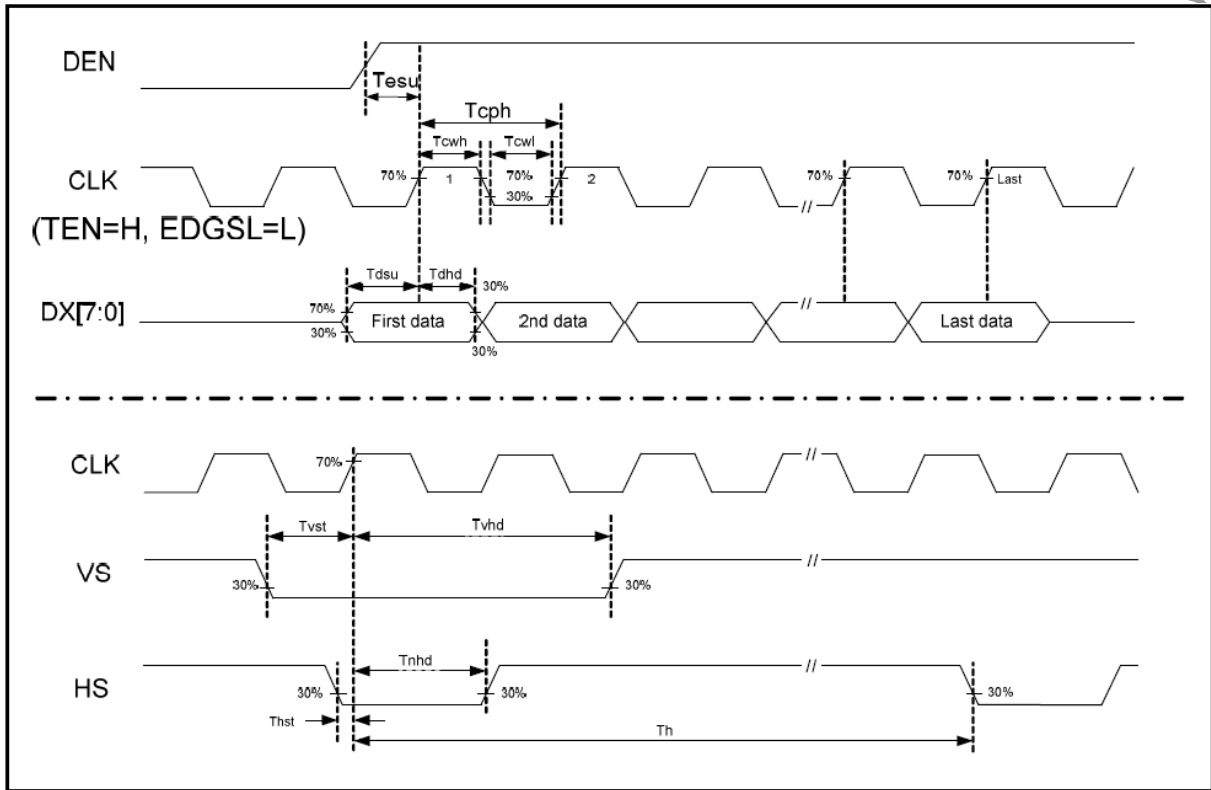

Fig. 7-1 Definition of VS falling to HS falling time



Preliminary

7.3 Power Sequence

The LCD panel power ON/OFF sequence is as below.

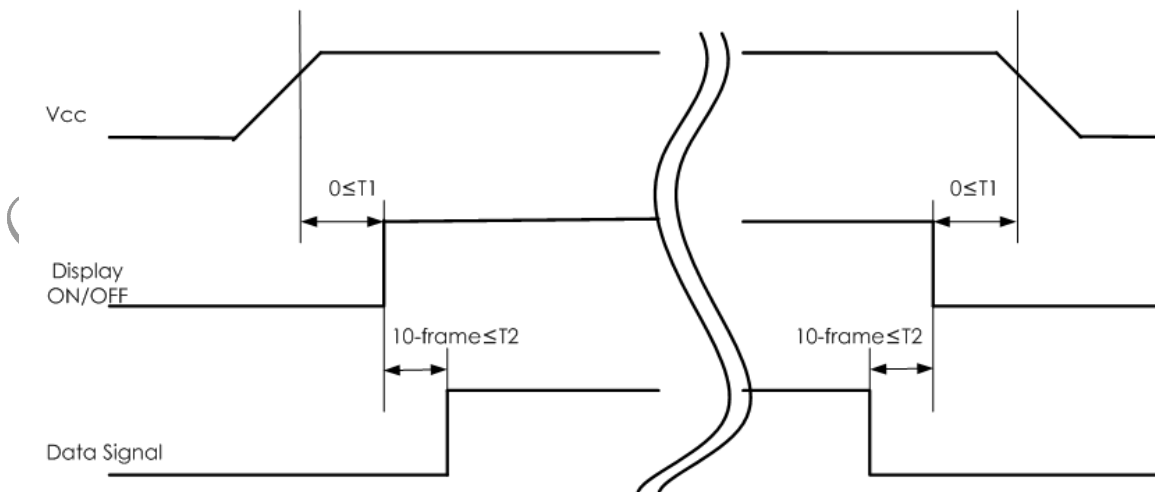

8. OPTICAL CHARACTERISTIC

Item	Symbol	Condition	Min	Typ	Max	Unit	Note
Brightness			300	350	-	cd/m ²	
Response time	TR	$\Theta=0$	-	15	-	ms	(2)
	TF		-	35	-	ms	
Contrast ratio	CR	At optimized viewing angle	350	400	-	-	(3)
Color Chromaticity	White	Wx	(0.26)	(0.31)	(0.36)	-	(4)
		Wy	(0.28)	(0.33)	(0.38)		
Viewing Angle	Hor.	Θ_R	-	70	-	Degree	(5)
		Θ_L	-	70	-		
	Ver.	ϕ_H	-	60	-		
		ϕ_L	-	70	-		

Ta=25±2°C, ILED=20mA

Note 1: Definition of viewing angle range

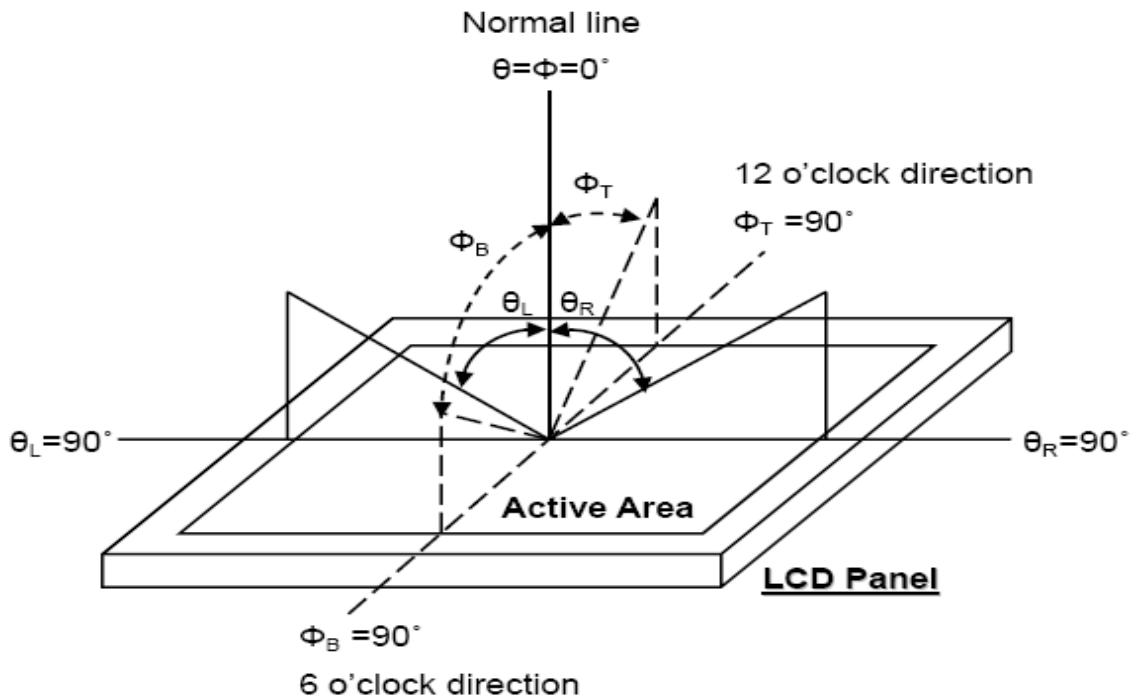

Fig. 8-1 Definition of viewing angle

Note 2: Test equipment setup:

After stabilizing and leaving the panel alone at a driven temperature for 10 minutes, the measurement should be executed. Measurement should be executed in a stable, windless, and dark room. Optical specifications are measured by Topcon BM-7 luminance meter 1.0° field of view at a distance of 50cm and normal direction.

Preliminary

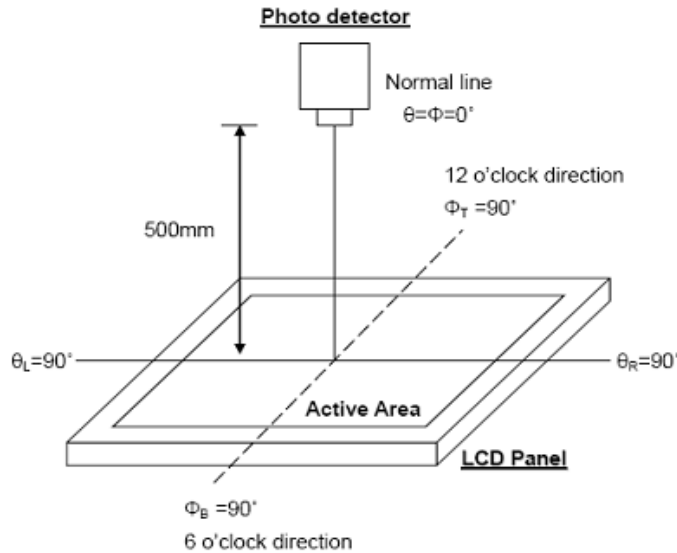

Fig. 8-2 Optical measurement system setup

Note 3: Definition of Response time:

The response time is defined as the LCD optical switching time interval between “White” state and “Black” state. Rise time, T_r , is the time between photo detector output intensity changed from 90% to 10%. And fall time, T_f , is the time between photo detector output intensity changed from 10% to 90%.

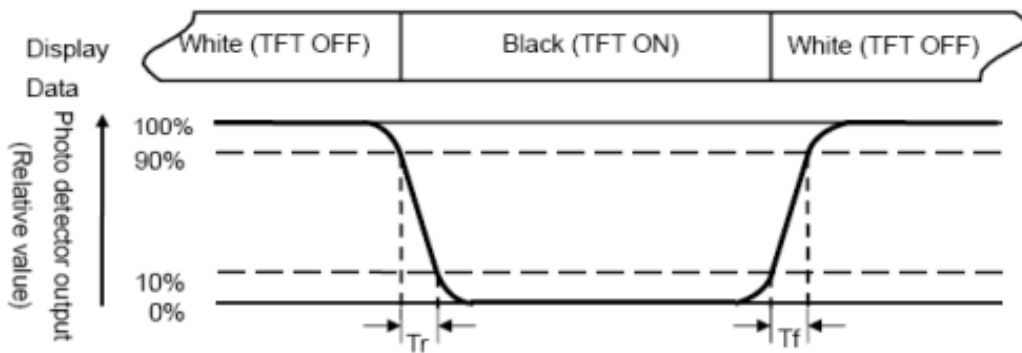

Fig. 3-3 Definition of response time

Note 4: Definition of contrast ratio:

The contrast ratio is defined as the following expression.

$$\text{Contrast ratio (CR)} = \frac{\text{Luminance measured when LCD on the "White" state}}{\text{Luminance measured when LCD on the "Black" state}}$$

Note 5: White $V_i = V_{i50} \pm 1.5V$

Black $V_i = V_{i50} \pm 2.0V$

“±” means that the analog input signal swings in phase with VCOM signal.

“±” means that the analog input signal swings out of phase with VCOM signal.

The 100% transmission is defined as the transmission of LCD panel when all the input terminals

Preliminary

of module are electrically opened.

Note 6: Definition of color chromaticity (CIE 1931)

Color coordinates measured at the center point of LCD

Note 7: Measured at the center area of the panel when all the input terminals of LCD panel are electrically opened.

Note 8 : Uniformity (U) = $\frac{\text{Brightness (min)}}{\text{Brightness (max)}} \times 100\%$

CHIHHSIN CONFIDENTIAL FOR REVIEW ONLY

Preliminary

9. INTERFACE

9.1. LCM PIN Definition

Pin	Symbol	I/O	Function	Remark
1	VLED-	I	LED Ground	
2	VLED+	I	LED Power	
3	DGND	I	Digital Ground	
4	VCC	I	Power Supply (+3.3 V)	
5	R0	I	Red Data Bit0	
6	R1	I	Red Data Bit1	
7	R2	I	Red Data Bit2	
8	R3	I	Red Data Bit3	
9	R4	I	Red Data Bit4	
10	R5	I	Red Data Bit5	
11	R6	I	Red Data Bit6	
12	R7	I	Red Data Bit7	
13	G0	I	Green Data Bit0	
14	G1	I	Green Data Bit1	
15	G2	I	Green Data Bit2	
16	G3	I	Green Data Bit3	
17	G4	I	Green Data Bit4	
18	G5	I	Green Data Bit5	
19	G6	I	Green Data Bit6	
20	G7	I	Green Data Bit7	
21	B0	I	Blue Data Bit0	
22	B1	I	Blue Data Bit1	
23	B2	I	Blue Data Bit2	
24	B3	I	Blue Data Bit3	
25	B4	I	Blue Data Bit4	
26	B5	I	Blue Data Bit5	
27	B6	I	Blue Data Bit6	
28	B7	I	Blue Data Bit7	
29	DGND	I	Digital Ground	
30	DCLK	I	Dot Data Clock	
31	DISP	I	Display On/Off	Note2
32	Hsync	I	Horizontal Sync Input	
33	Vsync	I	Vertical Sync Input	
34	DE	I	Data Enable Control	Note 1
35	N.C		N.C	

Preliminary

36	DGND	I	Digital Ground	
37	NC	I	No connection	
38	NC	I	No connection	
39	NC	I	No connection	
40	NC	I	No connection	

Note1: DE=" H ": data can be access, DE=" L ": data cannot be access

Note2: Usually pull high. High: Display On / Low: Display Off

CHIHSIN CONFIDENTIAL FOR REVIEW ONLY

Preliminary

10. BLOCK DIAGRAM

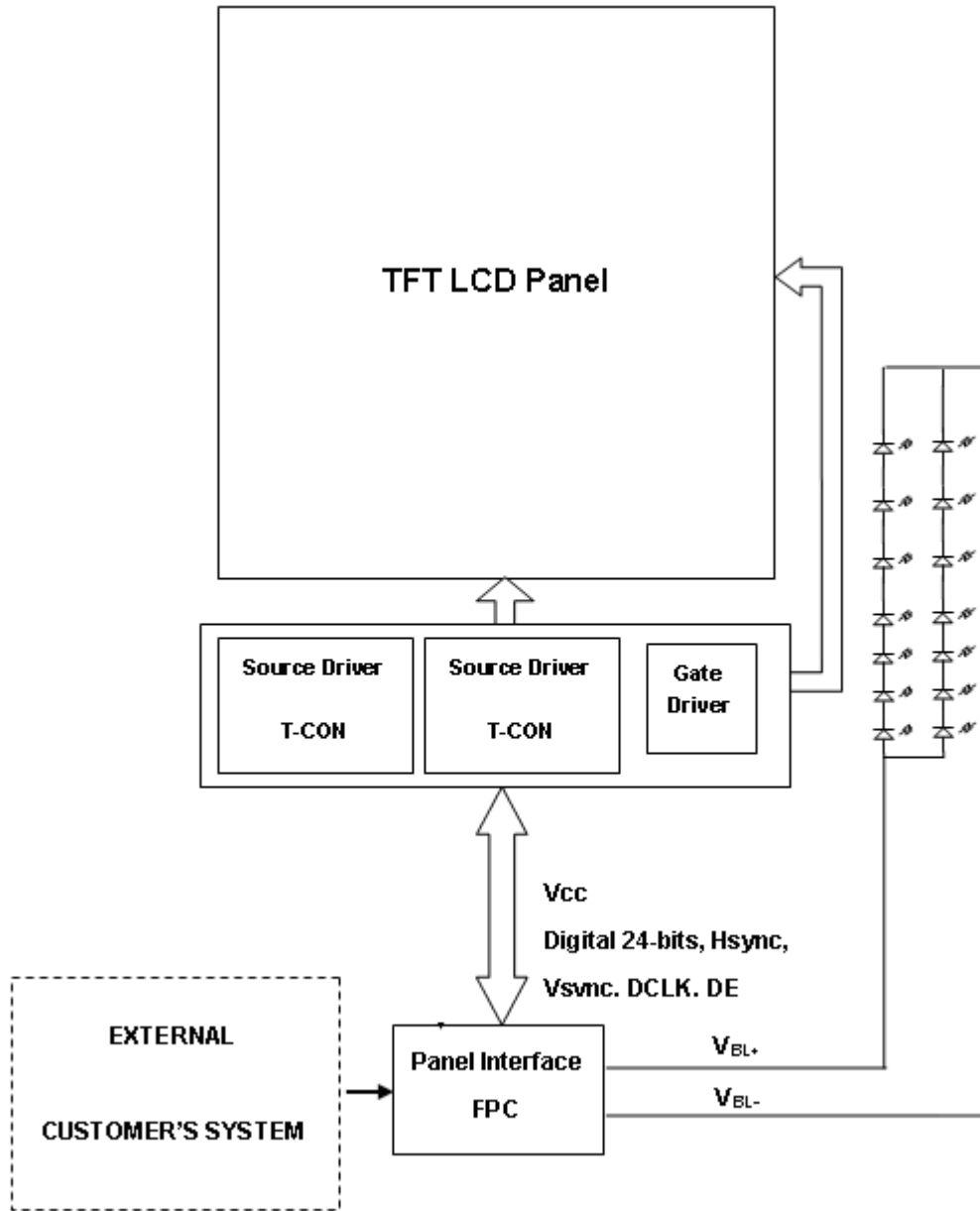

Preliminary

CHIHSIN

11. QUALITY ASSURANCE

No.	Test Items	Test Condition	REMARK
1	High Temperature Storage Test	Ta=80°C Dry 240h	
2	Low Temperature Storage Test	Ta=-30°C Dry 240h	
3	High Temperature Operation Test	Ta=70°C Dry 240h	
4	Low Temperature Operation Test	Ta=-20°C Dry 240h	
5	High Temperature and High Humidity Operation Test	Ta=60°C 90%RH 240h	
6	Electro Static Discharge Test	Panel surface / top case Contact / Air : ±6KV / ±8KV , 150pF , 330Ω	Non-operating
7	Shock Test (non-operating)	Shock Level : 100G Waveform : Half Sinusoidal Wave Shock Time : 6ms Number of Shocks : 3 times for each ±X, ±Y, ±Z direction	
8	Vibration Test (non-operating)	Frequency Range: 10~55Hz. Amplitude:1.5 mm. Sweep Time: 11min. Test Period : 6 cycles for each direction of X,Y,Z	
9	Thermal Shock Test	-25°C (0.5Hr) ~ +70°C (0.5Hr) for 200 cycles	

Note1: The test samples have recovery time for 2 hours at room temperature before the function check. In the standard conditions, there is no display function NG issue occurred.

Note2: All the cosmetic specifications are judged before the reliability stress.

Preliminary

CHIHSIN CONFIDENTIAL FOR REVIEW ONLY

14. PRECAUTIONS

Please pay attention to the following when you use this TFT LCD module.

14.1 MOUNTING PRECAUTIONS

- (1) You must mount a module using arranged in four corners or four sides.
- (2) You should consider the mounting structure so that uneven force (ex. Twisted stress) is not applied to the module.
And the case on which a module is mounted should have sufficient strength so that external force is not transmitted directly to the module.
- (3) Please attach a transparent protective plate to the surface in order to protect the polarizer. Transparent protective plate should have sufficient strength in order to the resist external force.
- (4) You should adopt radiation structure to satisfy the temperature specification.
- (5) Acetic acid type and chlorine type materials for the cover case are not describe because the former generates corrosive gas of attacking the polarizer at high temperature and the latter causes circuit break by electro-chemical reaction.
- (6) Do not touch, push or rub the exposed polarizers with glass, tweezers or anything harder than HB pencil lead. And please do not rub with dust clothes with chemical treatment. Do not touch the surface of polarizer for bare hand or greasy cloth. (Some cosmetics are determined to the polarizer)
- (7) When the surface becomes dusty, please wipe gently with adsorbent cotton or other soft materials like chamois soaks with petroleum benzene. Normal-hexane is recommended for cleaning the adhesives used to attach front / rear polarizers. Do not use acetone, toluene and alcohol because they cause chemical damage to the polarizer.
- (8) Wipe off saliva or water drops as soon as possible. Their long time contact with polarizer causes deformations and color fading.
- (9) Do not open the case because inside circuits do not have sufficient strength.

14.2 OPERATING PRECAUTIONS

- (1) The spike noise causes the mis-operation of circuits. It should be lower than following voltage : $V=\pm 200\text{mV}$ (Over and under shoot voltage)
- (2) Response time depends on the temperature. (In lower temperature, it becomes longer.)
- (3) Brightness depends on the temperature. (In lower temperature, it becomes lower)
And in lower temperature, response time (required time that brightness is stable after turned on) becomes longer.
- (4) Be careful for condensation at sudden temperature change. Condensation makes damage to polarizer or electrical contacted parts. And after fading condensation, smear or spot will occur.
- (5) When fixed patterns are displayed for a long time, remnant image is likely to occur.
- (6) Module has high frequency circuits. Sufficient suppression to the electromagnetic interference shall be done by system manufacturers. Grounding and shielding methods may be important to minimize the interference.

14.3 ELECTROSTATIC DISCHARGE CONTROL

Since a module is composed of electronic circuits, it is not strong to electrostatic discharge. Make certain that treatment persons are connected to ground through wristband etc. And don't touch interface pin directly.

14.4 PRECAUTIONS FOR STRONG LIGHT EXPOSURE

Strong light exposure causes degradation of polarizer and color filter.

14.5 STORAGE

When storing modules as spares for a long time, the following precautions are necessary.

- (1) Store them in a dark place. Do not expose the module to sunlight or fluorescent light. Keep the temperature between 5°C and 35°C at normal humidity.

- (2) The polarizer surface should not come in contact with any other object. It is recommended that they be stored in the container in which they were shipped.

14.6 HANDLING PRECAUTIONS FOR PROTECTION FILM

- (1) When the protection film is peeled off, static electricity is generated between the film and polarizer. This should be peeled off slowly and carefully by people who are electrically grounded and with well ion-blown equipment or in such a condition, etc.
- (2) The protection film is attached to the polarizer with a small amount of glue. Is apt to remain on the polarizer. Please carefully peel off the protection film without rubbing it against the polarizer.
- (3) When the module with protection film attached is stored for a long time, sometimes there remains a very small amount of glue still on the polarizer after the protection film is peeled off.
- (4) You can remove the glue easily. When the glue remains on the polarizer surface or its vestige is recognized, please wipe them off with absorbent cotton waste or other soft material like chamois soaked with normal-hexane.

Preliminary

CHIHSIN CONFIDENTIAL FOR REVIEW ONLY