

mass integrated

global part distribution • product lifecycle partner
excess inventory management • value-ad service provider



Data sheet provided by Mass Integrated

massintegrated.com • displayalliance.com

Please call +1.978.465.6190
Email: sales@massintegrated.com



ISO 9001: 2008

Mass Integrated complies with all DMCA takedown notices. Please send a formal DMCA Takedown Notice to Mass Integrated Systems, Inc. • 18 Henry Graf Jr. Road, Unit 1 • Newburyport, MA 01950.

**26 cm (10.4 inches), 640 × 480 pixels, 262,144 colors,
Incorporated two-lamp/Edge-light type backlight
Ultra Wide viewing angle**

DESCRIPTION

NL6448AC33-29 is a TFT (thin film transistor) active matrix color liquid crystal display (LCD) comprising amorphous silicon TFT attached to each signal electrode, a driving circuit and a backlight. NL6448AC33-29 has a built-in backlight. Backlight includes long-life-lamps and the lamps are replaceable.

The 26 cm (10.4 inches) diagonal display area contains 640 × 480 pixels and can display 262,144 colors simultaneously.

NL6448AC33-29 is suitable for industrial application use, because the viewing angle is ultra wide and the luminance is high. Also the viewing direction is selectable either upper or lower side changing scan direction.

FEATURES

- Ultra wide viewing angle with lateral electric field
- High luminance (250 cd/m², typ.)
- Low reflection
- 6-bit digital RGB interface
- Data enable (DE) function
- Incorporated edge type backlight with lamps (Two lamps, with inverter)
- Lamp holder replaceable (Type No.: 104LHS31)
- Reversible scan direction
- Variable luminance control
- Easy to assemble a touch panel
- No antiglare treatment

APPLICATIONS

- Display terminals for control system
- Monitors for process controller
- Industrial PC



The information in this document is subject to change without notice.

STRUCTURE AND FUNCTIONS

A color TFT (thin film transistor) LCD module is comprised of a TFT liquid crystal panel structure, LSIs for driving the TFT array, and a backlight assembly. The TFT panel structure is created by sandwiching liquid crystal material in the narrow gap between a TFT array glass substrate and a color filter glass substrate. After the driver LSIs are connected to the panel, the backlight assembly is attached to the backside of the panel.

RGB (red, green, blue) data signals from a source system is modulated into a form suitable for active matrix addressing by the onboard signal processor and sent to the driver LSIs which in turn addresses the individual TFT cells.

Acting as an electro-optical switch, each TFT cell regulates light transmission from the backlight assembly when activated by the data source. By regulating the amount of light passing through the array of red, green, and blue dots, color images are created with clarity.

BLOCK DIAGRAM

<1> In case of use the inverter of NEC

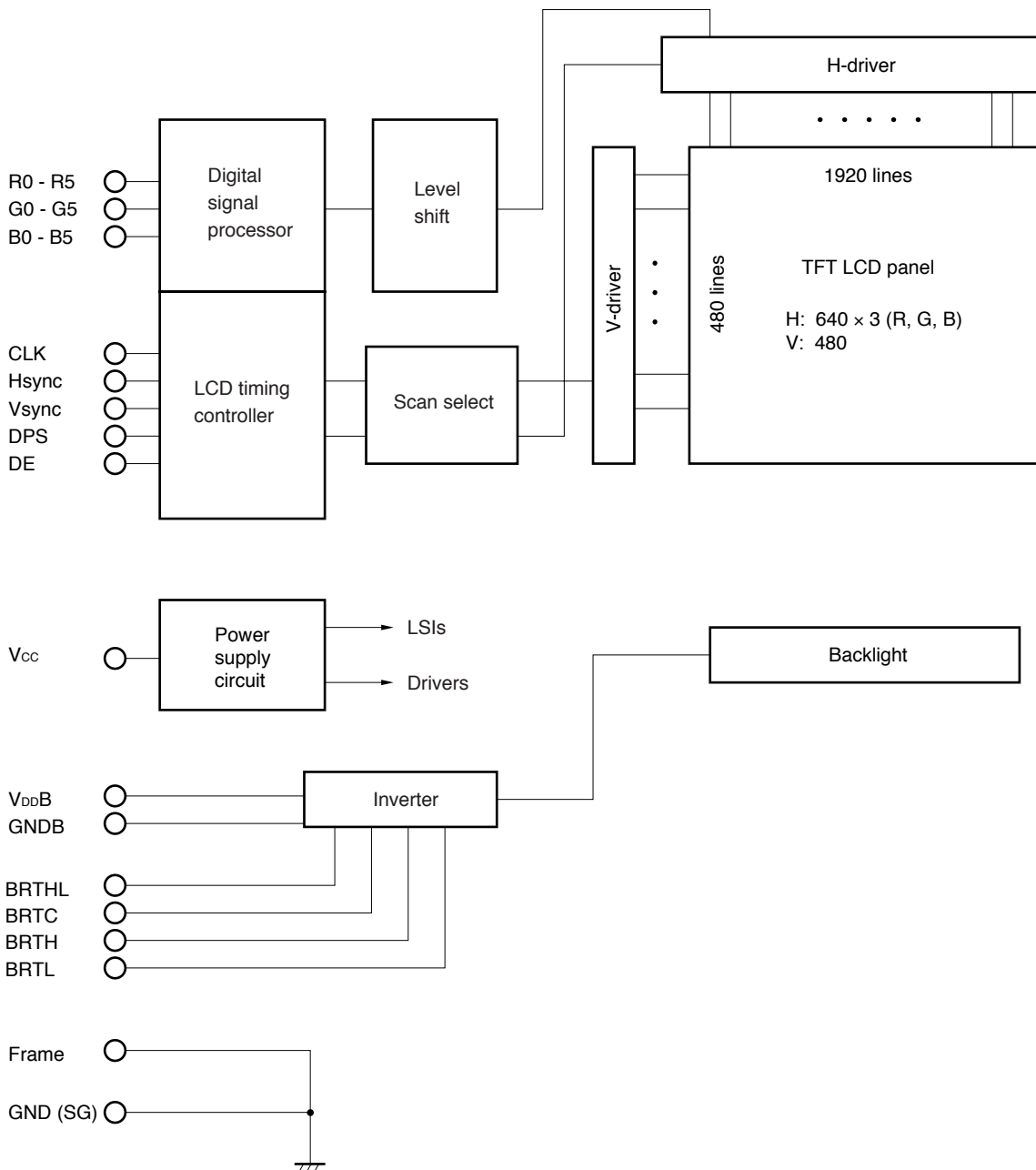

Note Both frame and GNDB (Backlight ground) are not contacted to the lamp holder.

<2> In case of use the inverter of customers

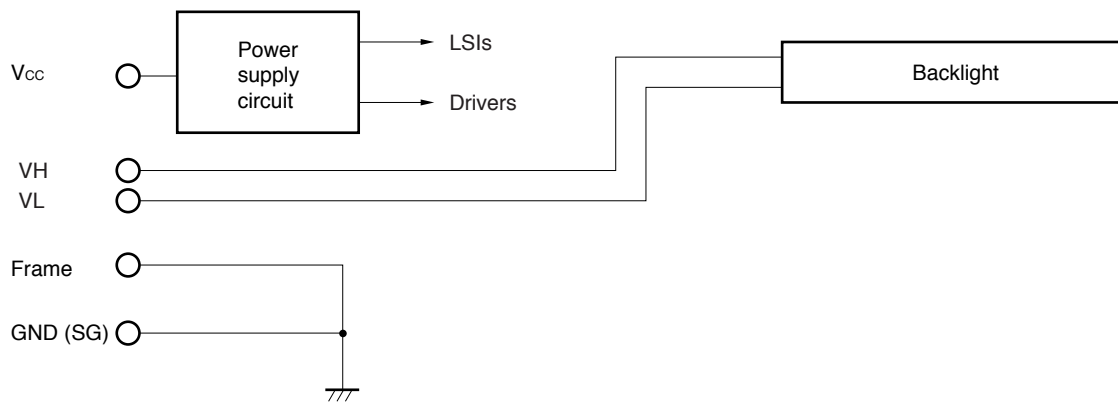
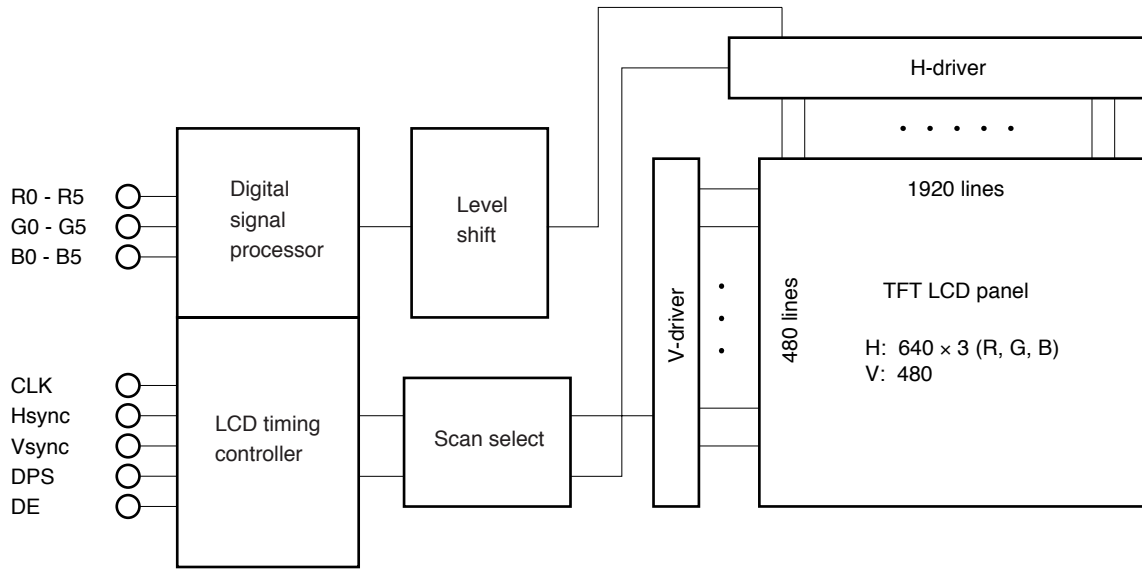

Note Both frame and GNDB (Backlight ground) are not contacted to the lamp holder.

OUTLINE OF CHARACTERISTICS (at room temperature)

Display area	211.2 (H) × 158.4 (V) mm
Drive system	a-Si TFT active matrix
Display colors	262,144 colors
Number of pixels	640 × 480 pixels
Pixel arrangement	RGB vertical stripe
Pixel pitch	0.33 (H) × 0.33 (V) mm
Module size	243.0 (H) × 185.1 (V) × 10.5 typ. (D) mm
Inverter size	25.0 (H) × 105.0 (V) × 10.2 max. (D) mm
Weight	510 g (typ.) + 15 g (typ., inverter)
Contrast ratio	150 : 1 (typ.)
Viewing angle (more than the contrast ratio of 10 : 1)	Horizontal : 80° (typ., left side, right side) Vertical : 80° (typ., up side, down side)
Designed viewing direction	Optimum grayscale ($\gamma = 2.2$): perpendicular
Color gamut	45% (typ., At center, to NTSC)
Response time	50 ms (typ.), black to white
Luminance	250 cd/m ² (typ.)
Signal system	6-bit digital signals for each of RGB primary colors, synchronous signals (Hsync, Vsync), dot clock (CLK)
Supply voltages	3.3 V [5.0 V] (Logic, LCD driving), 12.0 V (Backlight)
Backlight	Edge light type, two cold cathode fluorescent lamp
Power consumption	7.1 W (typ., 3.3 V, 12.0 V)

GENERAL SPECIFICATIONS

Item	Specification	Unit
Module size	243.0 ± 0.5 (H) × 185.1 ± 0.5 (V) × 11.2 max. (D)	mm
Inverter size	25.0 ± 0.5 (H) × 105.0 ^{+0.7} _{-0.3} (V) × 10.2 max. (D)	mm
Display area	211.2 (H) × 158.4 (V)	mm
Number of dots	640 × 3 (H) × 480 (V)	dot
Number of pixels	640 (H) × 480 (V)	pixel
Dot pitch	0.11 (H) × 0.33 (V)	mm
Pixel pitch	0.33 (H) × 0.33 (V)	mm
Pixel arrangement	RGB (Red, Green, Blue) vertical stripe	–
Display colors	262,144	color
Weight	Module: 530 (max.) + Inverter: 20 (max.)	g

ABSOLUTE MAXIMUM RATINGS

Parameter	Symbol	Rating	Unit	Remarks
Supply voltage	V _{CC}	–0.3 to 6.5	V	T _a = 25°C V _i – V _{CC} < 0.3
Input voltage	V _i	–0.3 to 6.5	V	
Supply voltage	V _{DD} B	–0.3 to 15.0	V	
Input voltage	BRTC	–0.3 to 7.0	V	
Lamp voltage	V _L	2000	V _{rms}	
Storage temp.	T _{ST}	–20 to 60	°C	–
Operating temp.	T _{OP}	0 to 50	°C	Module surface ^{Note}
Humidity (No condensation)	RH	≤ 95% relative humidity	–	T _a ≤ 40°C
		≤ 85% relative humidity	–	40 < T _a ≤ 50°C
		Absolute humidity shall not exceed T _a = 50°C, 85% relative humidity level.	–	T _a > 50°C

Note Measured at the display area

SUPPLY VOLTAGE SEQUENCE

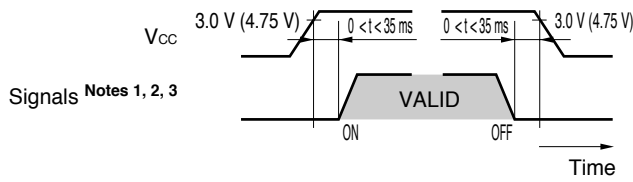

- Notes**
1. The supply voltage for input signals should be the same as V_{CC}.
 2. Apply V_{DD}B within the LCD operation period. When the backlight turns on before LCD operation or the LCD operation turns off before the backlight turns off, the display may momentarily become white.
 3. While the power is off, please keep whole signals (Hsync, Vsync, CLK, DE, and DATA) at low level or high impedance.

INTERFACE AND PIN CONNECTION

(1) Interface signals, power supply

Module side connector	Mating connector
CN1 ... DF9C-31P-1V (No.1 to 31)	DF9-31S-1V, DF9M-31S-1R (1)
	IL-310-T31S-VF (2)

Supplier: (1) HIROSE ELECTRIC CO., LTD., (2) Japan Aviation Electronics Industry Limited (JAE)

Pin No.	Symbol	Function
1	GND	Ground (SG) ^{Note 4}
2	CLK	Dot clock
3	Hsync	Horizontal sync.
4	Vsync	Vertical sync.
5	GND	Ground ^{Note 4}
6	R0	Red data (LSB)
7	R1	Red data
8	R2	Red data
9	R3	Red data
10	R4	Red data
11	R5	Red data (MSB)
12	GND	Ground ^{Note 4}
13	G0	Green data (LSB)
14	G1	Green data
15	G2	Green data
16	G3	Green data
17	G4	Green data
18	G5	Green data (MSB)

Pin No.	Symbol	Function
19	GND	Ground ^{Note 4}
20	B0	Blue data (LSB)
21	B1	Blue data
22	B2	Blue data
23	B3	Blue data
24	B4	Blue data
25	B5	Blue data (MSB)
26	GND	Ground ^{Note 4}
27	DE	Data enable ^{Note 2}
28	V _{CC}	Power supply ^{Note 1}
29	V _{CC}	Power supply ^{Note 1}
30	N. C.	Non-connection
31	DPS	Scan direction select ^{Note 3}

LSB : Least Significant Bit

MSB : Most Significant Bit

Notes 1. V_{CC}: All V_{CC} terminals should be connected to 3.3 V or 5.0 V.

2. DE: DE/Fixed mode select is as follows.

$\left\{ \begin{array}{l} \text{Data enabled signal} = \text{DE mode} \\ \text{V}_{CC} \text{ or Open} = \text{Fixed mode} \end{array} \right.$

3. DPS: DPS changes display scan direction.

$\left\{ \begin{array}{l} \text{GND or Open} = \text{Scan direction will be decided by the setting of SW1.} \\ \text{V}_{CC} = \text{Reverse scan} \end{array} \right.$

INPUT SIGNAL TIMING See (4) DISPLAY POSITION about another way for reversible scan. (DPS is Open)

When DPS is V_{CC}, reverse scan is selected even if SW1 is set at normal scan.

When DPS is GND, normal scan is selected even if SW1 is set at reverse scan.

4. GND is connected to the frame of the LCD module.

(2) Inverter

- Inverter side connector 1 Mating connector 1
 CN1 ... LZ-5P-SL-SMT LZ-5S-SC3

Supplier: Japan Aviation Electronics Industry Limited (JAE)

Pin No.	Symbol	Function	Pin No.	Symbol	Function
1	V _{DD} B	Power supply	4	GNDB	Backlight ground
2	V _{DD} B	Power supply	5	BRTHL	Luminance select ^{Note}
3	GNDB	Backlight ground			

Note High luminance (100%): BRTHL = High or open
 Low luminance (60%): BRTHL = Low (GNDB level)

- Inverter side connector 2 Mating connector 2
 CN3 ... IL-Z-3PL-SMTY IL-Z-3S-S125C3

Supplier: Japan Aviation Electronics Industry Limited (JAE)

Pin No.	Symbol	Function
1	BRTC	Backlight ON/OFF signal ^{Note 1}
2	BRTH	Luminance control input ^{Note 2}
3	BRTL	Luminance control input ^{Note 2}

Notes 1. C-MOS level

Backlight ON : BRTC = High or open

Backlight OFF : BRTC = Low

- 2.** <1> A way of luminance control by a variable resistor
 This way works when BRTHL (No.5 pin) of CN1 is opened.

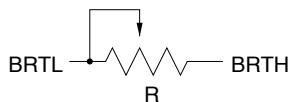

Mating variable resistor : 10 kΩ ±5%
 Minimum luminance (50%) : R = 0 Ω
 Maximum luminance (100%): R = 10 kΩ

- <2> A way of luminance control by a voltage
 This way works when BRTHL and BRTL are opened. The range of input voltage between BRTH and GNDB is as follows.
 Minimum luminance (50%) : 2.5 V
 Maximum luminance (100%): ≤ 1.2 V

<3> Connector location

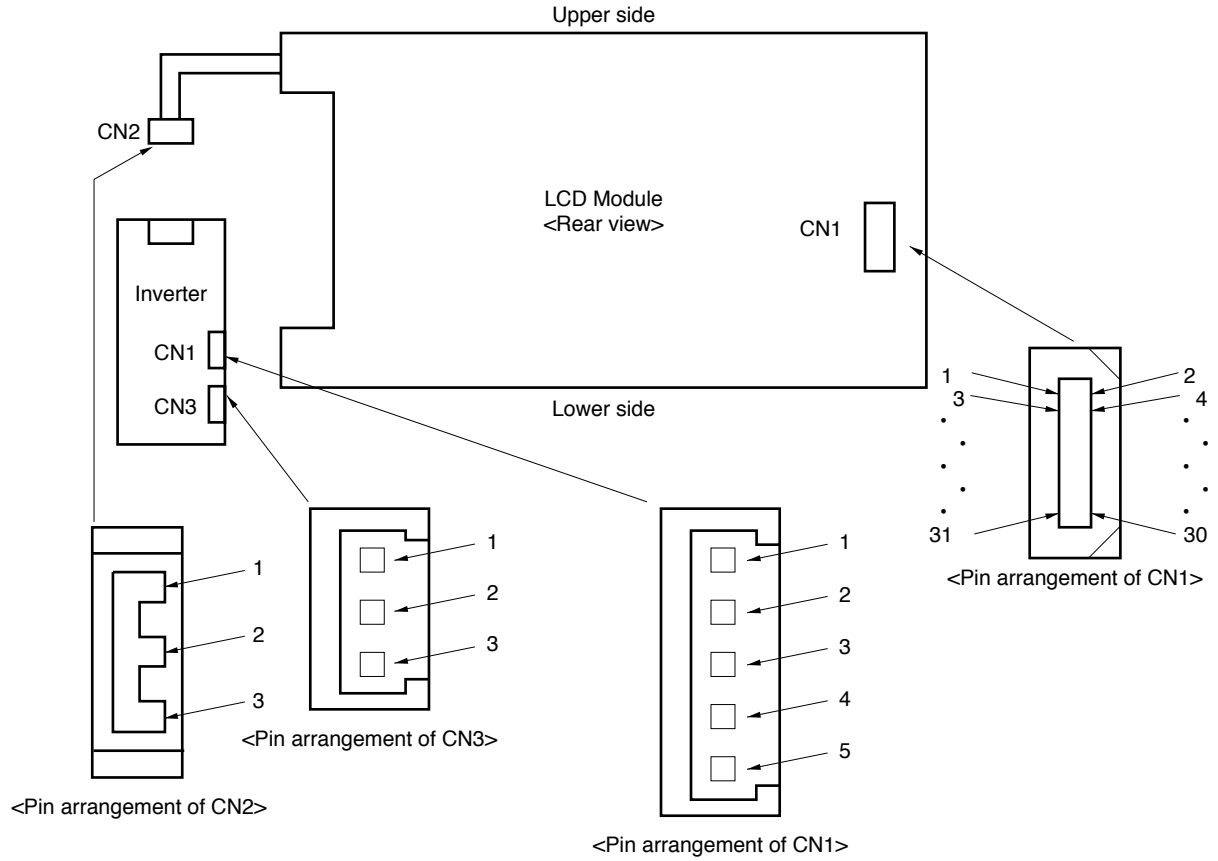

[In case of use the inverter of customers]

Lamp side connector Mating connector
 CN2 ... BHR-03VS-1 SM03 (4.0) B-BHS-TB
 Supplier: J. S. T TRADING COMPANY, LTD.

Pin No.	Symbol	Function
1	VL	Low voltage terminal
2	VH	High voltage terminal
3	VH	High voltage terminal

<1> Connector location

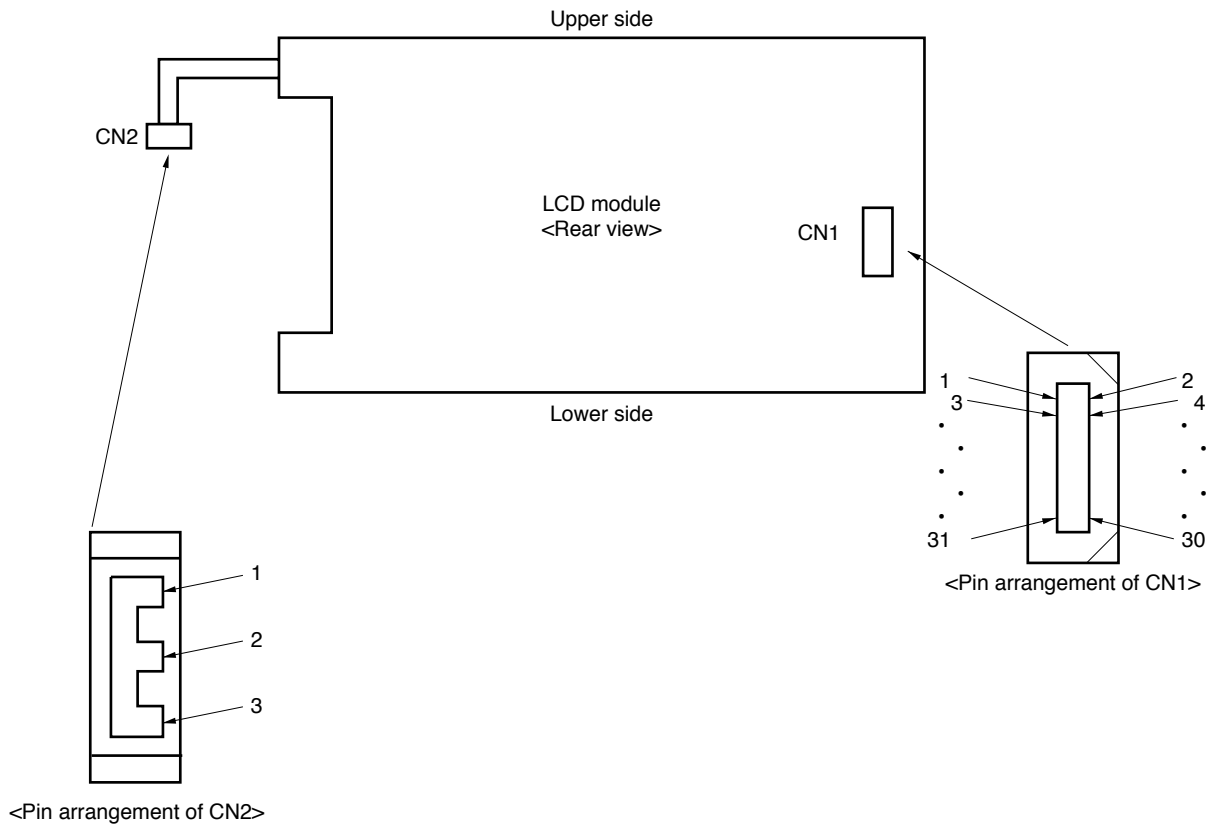

DISPLAY COLORS vs. INPUT DATA SIGNALS

Display colors		Data signal (0: Low level, 1: High level)																	
		R5	R4	R3	R2	R1	R0	G5	G4	G3	G2	G1	G0	B5	B4	B3	B2	B1	B0
Basic colors	Black	0	0	0	0	0	0	0	0	0	0	0	0	0	0	0	0	0	0
	Blue	0	0	0	0	0	0	0	0	0	0	0	0	1	1	1	1	1	1
	Red	1	1	1	1	1	1	0	0	0	0	0	0	0	0	0	0	0	0
	Magenta	1	1	1	1	1	1	0	0	0	0	0	0	1	1	1	1	1	1
	Green	0	0	0	0	0	0	1	1	1	1	1	1	0	0	0	0	0	0
	Cyan	0	0	0	0	0	0	1	1	1	1	1	1	1	1	1	1	1	1
	Yellow	1	1	1	1	1	1	1	1	1	1	1	1	0	0	0	0	0	0
	White	1	1	1	1	1	1	1	1	1	1	1	1	1	1	1	1	1	1
Red grayscale	Black	0	0	0	0	0	0	0	0	0	0	0	0	0	0	0	0	0	0
		0	0	0	0	0	1	0	0	0	0	0	0	0	0	0	0	0	0
	dark	0	0	0	0	1	0	0	0	0	0	0	0	0	0	0	0	0	0
	↑																		
	↓																		
	bright	1	1	1	1	0	1	0	0	0	0	0	0	0	0	0	0	0	0
	Red	1	1	1	1	1	0	0	0	0	0	0	0	0	0	0	0	0	0
Green grayscale	Black	0	0	0	0	0	0	0	0	0	0	0	0	0	0	0	0	0	0
		0	0	0	0	0	0	0	0	0	0	1	0	0	0	0	0	0	0
	dark	0	0	0	0	0	0	0	0	0	1	0	0	0	0	0	0	0	0
	↑																		
	↓																		
	bright	0	0	0	0	0	0	1	1	1	1	0	1	0	0	0	0	0	0
	Green	0	0	0	0	0	0	1	1	1	1	1	1	0	0	0	0	0	0
Blue grayscale	Black	0	0	0	0	0	0	0	0	0	0	0	0	0	0	0	0	0	0
		0	0	0	0	0	0	0	0	0	0	0	0	0	0	0	0	0	1
	dark	0	0	0	0	0	0	0	0	0	0	0	0	0	0	0	0	1	0
	↑																		
	↓																		
	bright	0	0	0	0	0	0	0	0	0	0	0	0	1	1	1	1	0	1
	Blue	0	0	0	0	0	0	0	0	0	0	0	0	1	1	1	1	1	1

Note Colors are developed in combination with 6-bit signals (64 steps in grayscale) of each primary red, green, and blue color.
 This process can result in up to 262,144 (64 × 64 × 64) colors.

INPUT SIGNAL TIMING

(1) Input signal specifications (DE mode)

Parameter		Symbol	MIN.	TYP.	MAX.	Unit	Remarks
CLK	Frequency	1/tc	21.0	25.175	29.0	MHz	39.72 ns (typ.)
	Duty	tch/tc	0.4	0.5	0.6	–	–
	Rise, fall	tcrf	–	–	10	ns	–
Hsync	Period	th	30.0	31.778	33.6	μs	31.468 kHz (typ.)
			–	800	–	CLK	
	Display period	thd	640			CLK	–
	Front-porch	thf	16			CLK	Fixed mode
			2	16	–	CLK	–
	Pulse width	thp	–	96	–	CLK	Fixed mode
			10	96	–	CLK	–
	Back-porch	thb	–	48	134	CLK	Fixed mode
			4	48	–	CLK	Adjustable range by DE signal
	thp + thb		144			CLK	Fixed mode
			14	144	–	CLK	Adjustable range by DE signal
	CLK-Hsync timing	thch	12	–	–	ns	–
	Hsync-CLK timing	thcs	8	–	–	ns	–
	Hsync-Vsync timing	tvh	1	–	–	CLK	–
Vsync-Hsync timing	tvS	30	–	–	ns	–	
Rise, fall	thrf	–	–	10	ns	–	
Vsync	Period	tv	16.1	16.683	17.2	ms	59.94 Hz (typ.)
			–	525	–	H	
	Display period	tvd	480			H	–
	Front-porch	tvf	–	12	–	H	Fixed mode
			0	12	–	H	–
	Pulse width	tvp	1	2	–	H	Fixed mode
			1	2	–	H	–
	Back-porch	tvb	–	31	–	H	Fixed mode
			4	31	–	H	Adjustable range by DE signal
	tvp + tvb		–	33	–	H	Fixed mode
5			33	–	H	Adjustable range by DE signal	
Rise, fall	tvrf	–	–	10	ns	–	
DATA (R0-R5 G0-G5 B0-B5)	CLK-DATA timing	tds	8	–	–	ns	–
	DATA-CLK timing	tdh	12	–	–	ns	–
	Rise, fall	tdrf	–	–	10	ns	–
DE	DE-CLK timing	tes	8	–	–	ns	–
	CLK-DE timing	teh	12	–	–	ns	
	Rise, fall	terf	–	–	10	ns	

Caution All of parameters should be kept in the specified range.

(2) Definition of input signal timing

<Vertical>

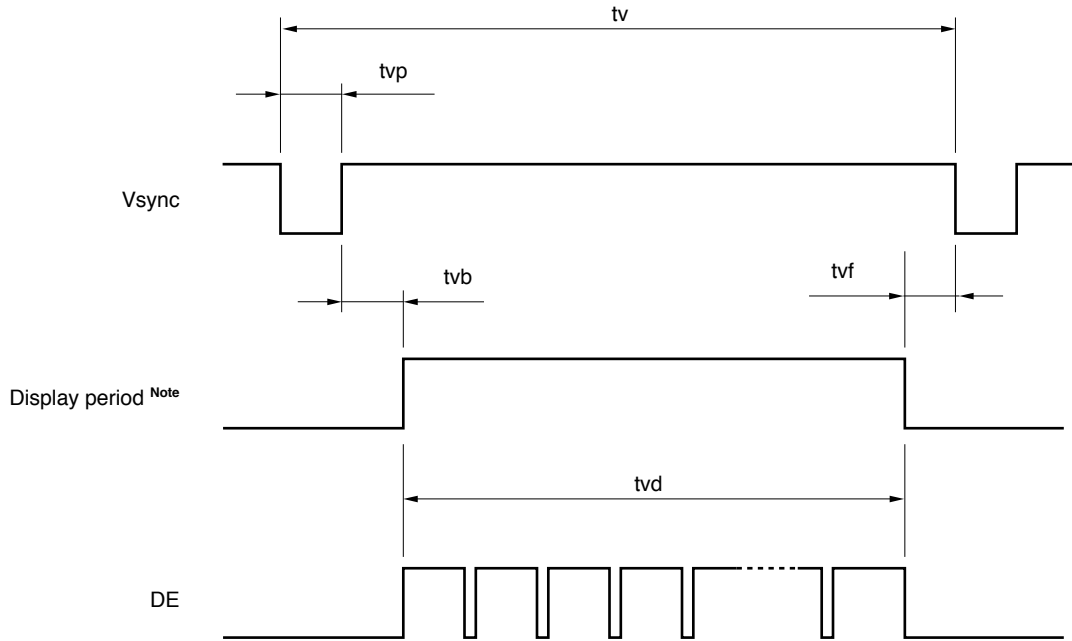

<Horizontal>

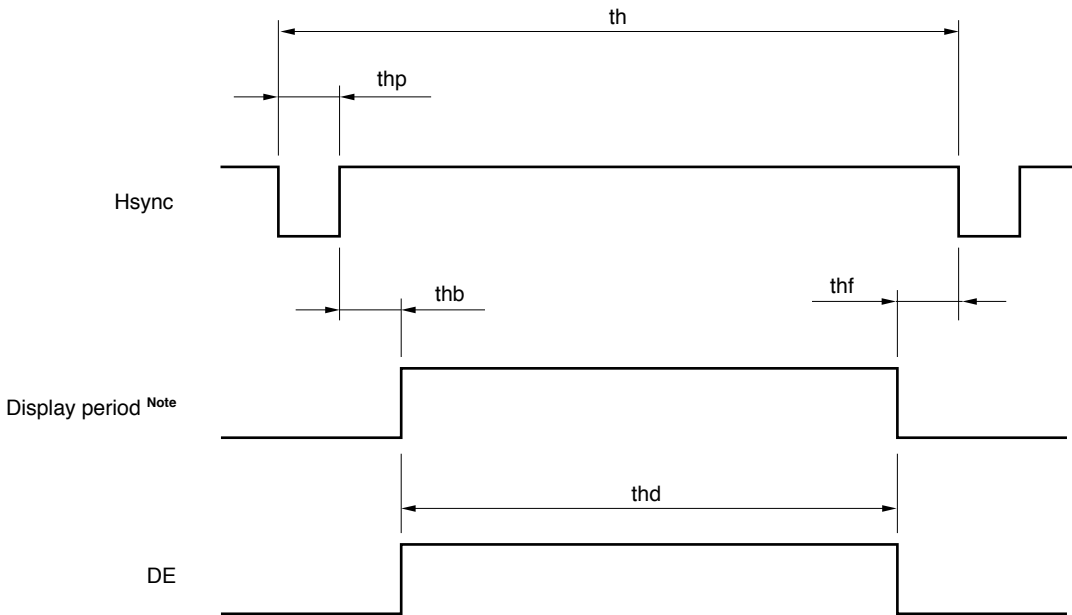

Notes 1. These do not exist as signals.

2. Keep $thp + thb$ and $thp + tvb$ within the value shown in the table of input signal timing, otherwise display position is shifted to right or left side, or to up or down side.

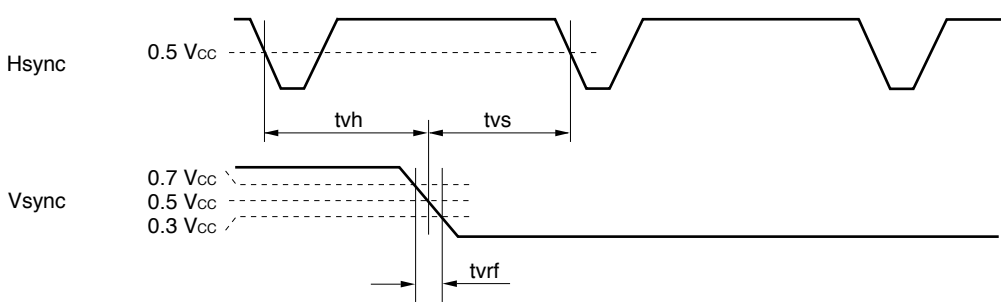
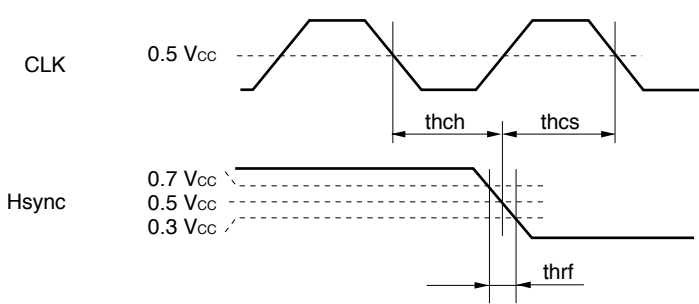
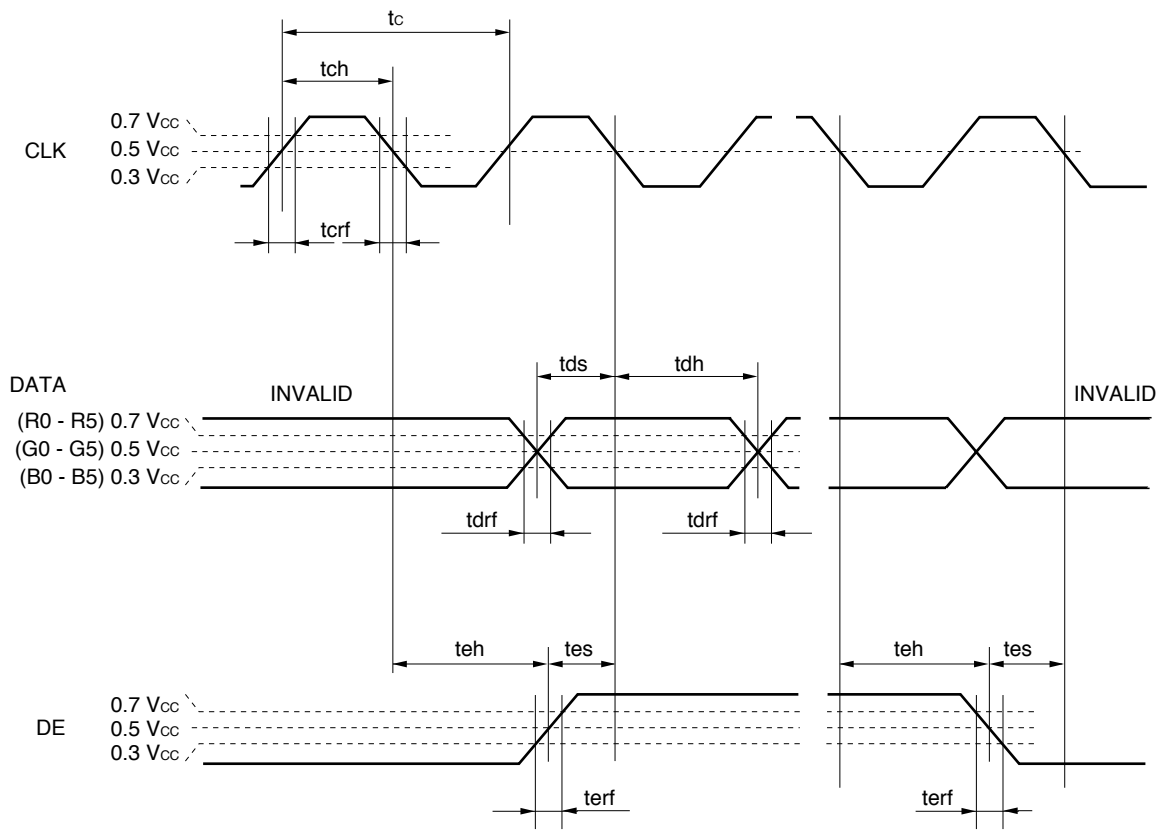

(3) Input signal timing chart

(a) Fixed mode

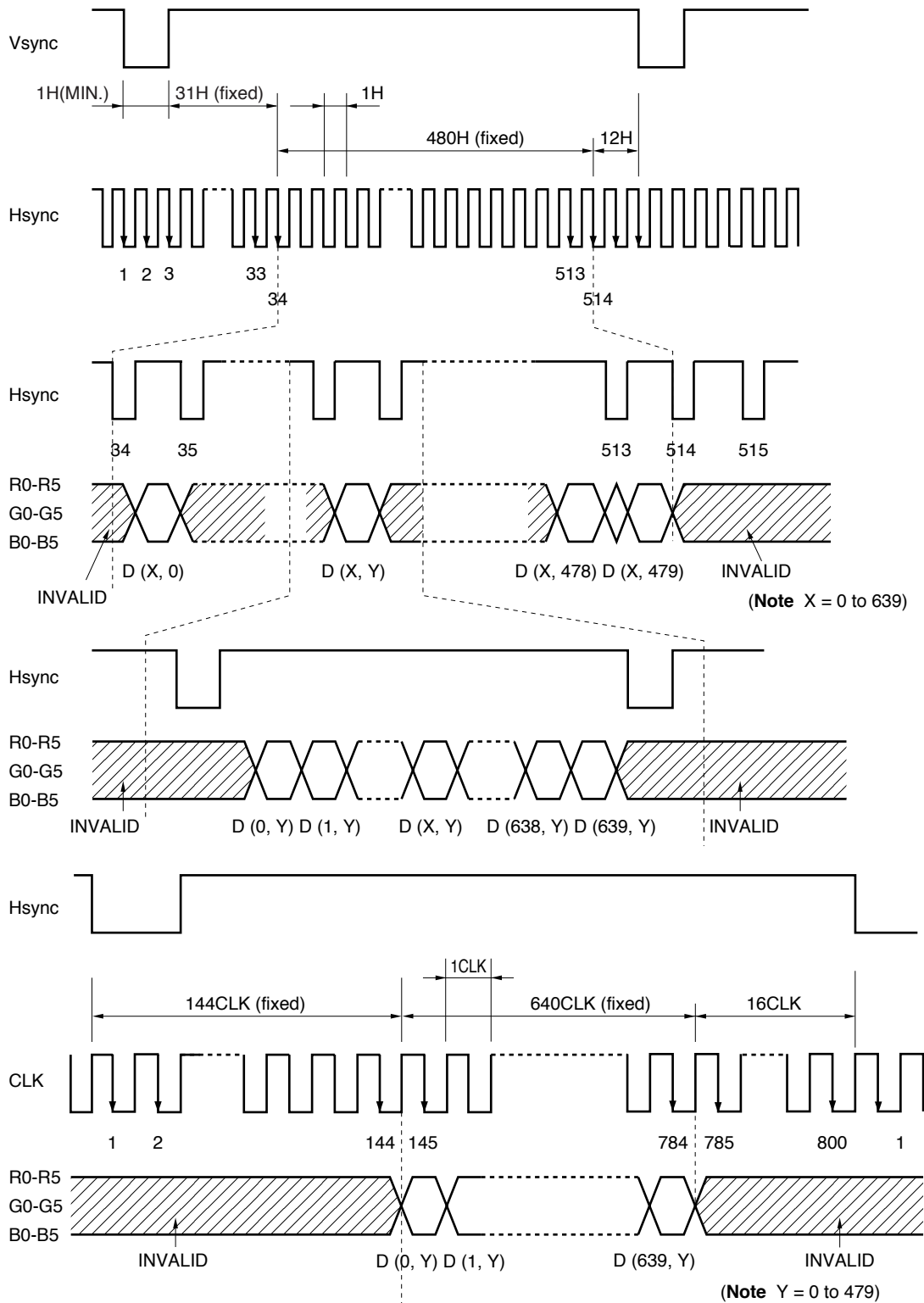

(b) DE mode

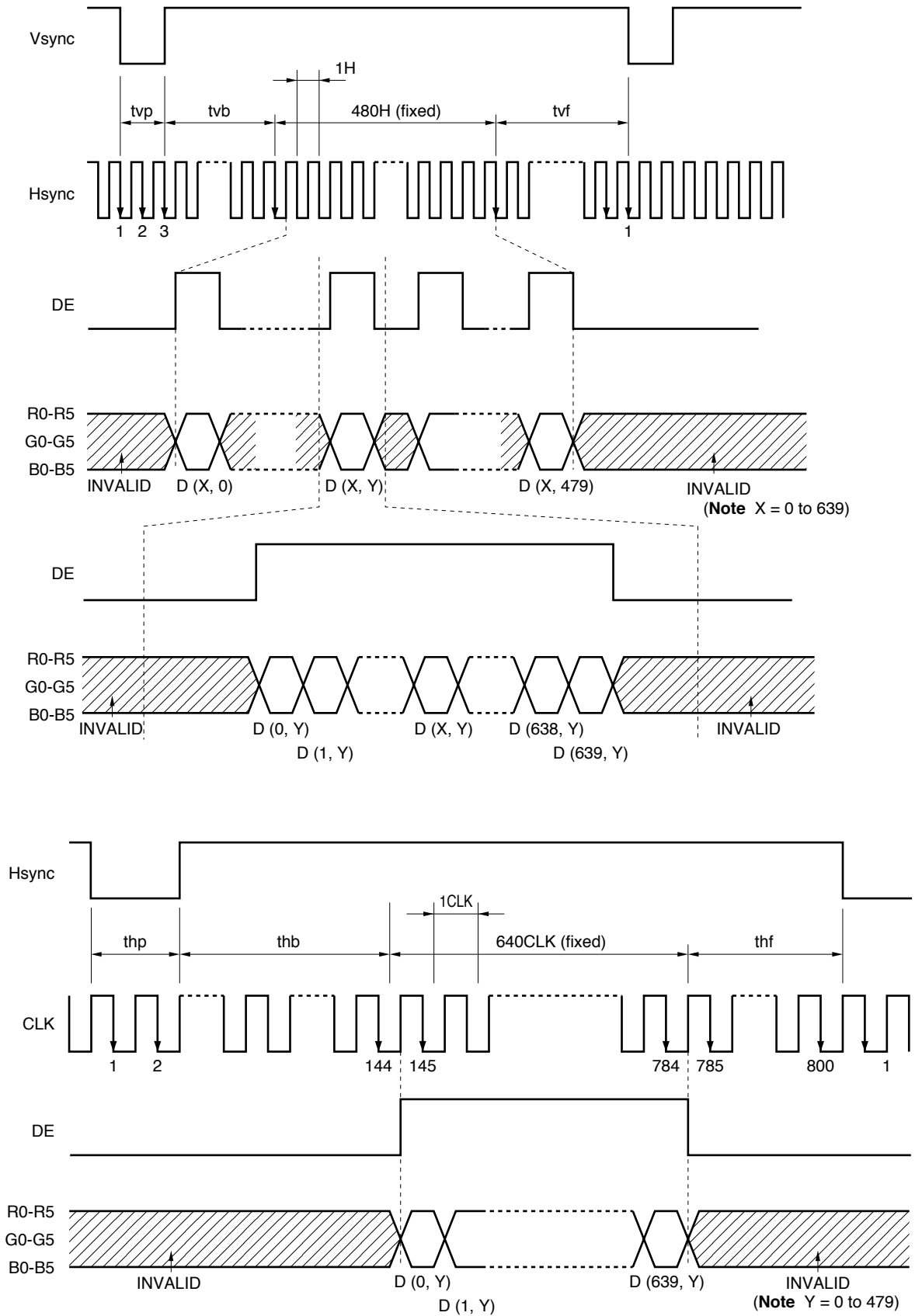

(4) Display position of input data

Normal scan (DPS = "GND" or "Open")

D (0, 0)	D (1, 0)	---	D (X, 0)	---	D (638, 0)	D (639, 0)
D (0, 1)	D (1, 1)	---	D (X, 1)	---	D (638, 1)	D (639, 1)
⋮	⋮	⋮	⋮	⋮	⋮	⋮
D (0, Y)	D (1, Y)	---	D (X, Y)	---	D (638, Y)	D (639, Y)
⋮	⋮	⋮	⋮	⋮	⋮	⋮
D (0, 478)	D (1, 478)	---	D (X, 478)	---	D (638, 478)	D (639, 478)
D (0, 479)	D (1, 479)	---	D (X, 479)	---	D (638, 479)	D (639, 479)

Reverse scan (DPS = "V_{CC}")

D (639, 479)	D (638, 479)	---	D (X, 479)	---	D (1, 479)	D (0, 479)
D (639, 478)	D (638, 478)	---	D (X, 478)	---	D (1, 478)	D (0, 478)
⋮	⋮	⋮	⋮	⋮	⋮	⋮
D (639, Y)	D (638, Y)	---	D (X, Y)	---	D (1, Y)	D (0, Y)
⋮	⋮	⋮	⋮	⋮	⋮	⋮
D (639, 1)	D (638, 1)	---	D (X, 1)	---	D (1, 1)	D (0, 1)
D (639, 0)	D (638, 0)	---	D (X, 0)	---	D (1, 0)	D (0, 0)

Notes 1. Below drawings shows relation between the scan direction and viewing direction.

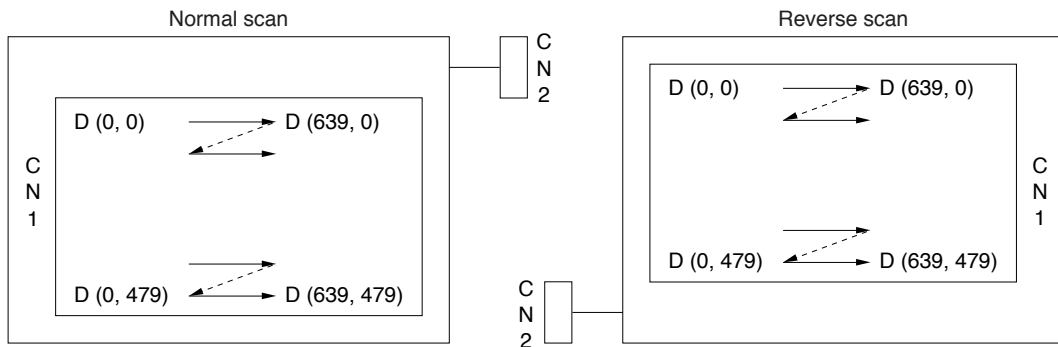

2. When DPS is open, or Low, the scan direction is set up by the switch (SW1) on the rear side.

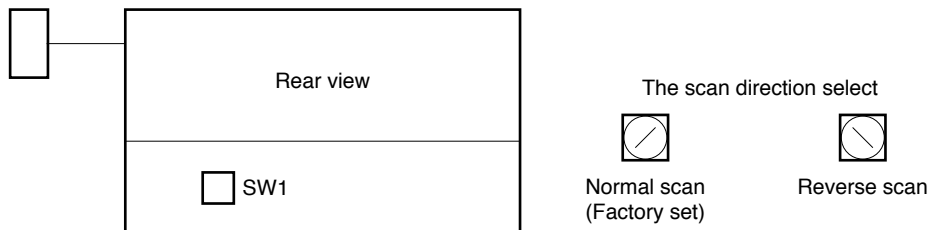

See (1) Interface signals, power supply about another way for reversible scan.
When DPS is V_{CC}, reverse scan is selected even if SW1 is set at normal scan.

OPTICAL CHARACTERISTICS

V_{CC} = 3.3 V, V_{DD}B = 12 V, MAV = “V_{CC}” or “Open” at normal scan

Parameter	Symbol	Condition	min.	typ.	max.	Unit	
Luminance	LVMAX	$\theta X = \pm 0^\circ, \theta Y = \pm 0^\circ$, at center Note 1	200	250	–	cd/m ²	
Contrast ratio	CR	$\theta X = \pm 0^\circ, \theta Y = \pm 0^\circ$, at center Note 2	80	150	–	–	
Viewing angle range Note 3	Horizontal	$\theta X+$	CR > 10, $\theta Y = \pm 0^\circ$,	70	80	–	deg.
		$\theta X-$	CR > 10, $\theta Y = \pm 0^\circ$,	70	80	–	deg.
	Vertical	$\theta Y+$	CR > 10, $\theta X = \pm 0^\circ$	70	80	–	deg.
		$\theta Y-$	CR > 10, $\theta X = \pm 0^\circ$	70	80	–	deg.
Color gamut	C	at center, to NTSC	40	45	–	%	
Response time Note 4	ton	Black to white	–	50	70	ms	
	toff	White to black	–	50	80	ms	
Luminance uniformity Note 5	–	Maximum luminance	–	1.25	1.4	–	
		Minimum luminance	–	–	–	–	

Notes 1. The luminance is measured after 20 minutes from the module works, with all pixels in white. Typical value is measured after luminance saturation.

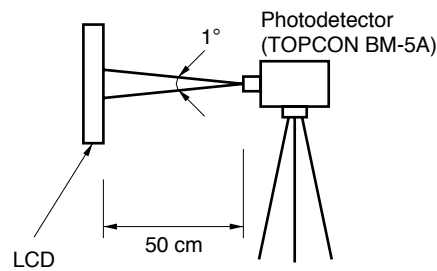

2. The contrast ratio is calculated by using the following formula.

$$\text{Contrast ratio (CR)} = \frac{\text{Luminance with all pixels in white}}{\text{Luminance with all pixels in black}}$$

The Luminance is measured in darkroom.

3. Definitions of viewing angle are as follows.

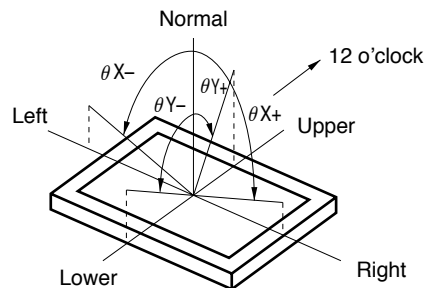

4. Definition of response time is as follows.

Photodetector output signal is measured when the luminance changes “black” to “white” or “white” to “black”.

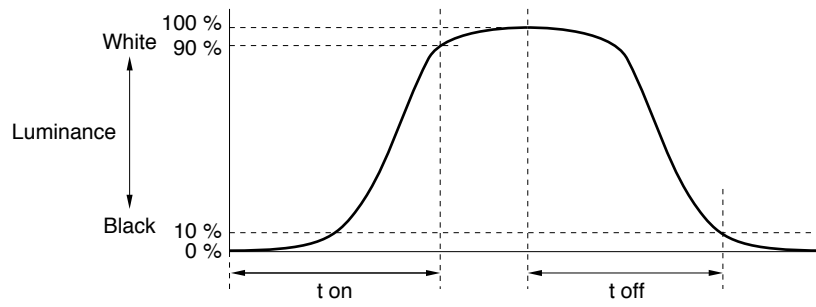

5. The luminance uniformity is calculated using following formula.

$$\text{Luminance uniformity} = \frac{\text{Maximum luminance}}{\text{Minimum luminance}}$$

The luminance is measured at near the five points shown below.

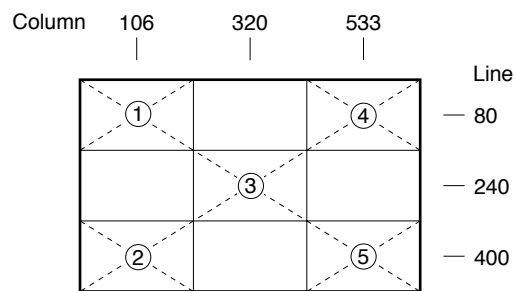

RELIABILITY TEST

Test item	Test condition
High temperature/humidity operation ^{Note 1}	50 ± 2°C, 85% relative humidity 240 hours Display data is black.
Heat cycle ^{Note 1} (operation)	<1> 0°C ± 3°C ... 1 hour 55°C ± 3°C ... 1 hour <2> 50 cycles, 4 hours/cycle <3> Display data is black.
Thermal shock ^{Note 1} (non-operation)	<1> -20°C ± 3°C ... 30 minutes 60°C ± 3°C ... 30 minutes <2> 100 cycles <3> Temperature transition time within 5 minutes
Vibration ^{Notes 1, 2} (non-operation)	<1> 5 - 100 Hz, 2G 1 minute/cycle X, Y, Z direction <2> 120 times each direction
Mechanical shock ^{Notes 1, 2} (non-operation)	<1> 55 G, 11 ms X, Y, Z direction <2> 5 times each direction
ESD ^{Notes 1, 3} (operation)	150 pF, 150 Ω, ±10 kV 9 places on a panel 10 times each place at one-second intervals
Dust ^{Note 1} (operation)	15 kinds of dust (JIS Z 8901) Hourly 15 seconds stir, 8 times repeat

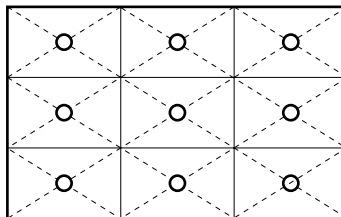

- Notes 1.** Display function is checked by the same condition as LCD module out-going inspection.
2. Physical damage.
3. Discharge points “O” are shown in the figure.



GENERAL CAUTIONS

Next figures and sentence are very important. Please understand these contents as follows.

	CAUTION This figure is a mark that you will get hurt and/or the module will have damages when you make a mistake to operate.
---	--

	This figure is a mark that you will get an electric shock when you make a mistake to operate.
	This figure is a mark that you will get hurt when you make a mistake to operate



	Do not touch an inverter, on which is stuck a caution label, while the LCD module is under the operation, because of dangerous high voltage.
---	--

- (1) Caution when taking out the module
 - a) Pick the pouch only, in taking out module from a carrier box.
- (2) Cautions for handling the module
 - a) As the electrostatic discharges may break the LCD module, handle the LCD module with care against electrostatic discharges.
 - b)  As the LCD panel and backlight element are made from fragile glass material, impulse and pressure to the LCD module should be avoided.
 - c) As the surface of polarizer is very soft and easily scratched, use a soft dry cloth without chemicals for cleaning.
 - d) Do not pull the interface connectors in or out while the LCD module is operating.
 - e) Put the module display side down on a horizontal plane.
 - f) Handle connectors and cables with care.
 - g) When the module is operating, do not lose CLK, Hsync or Vsync signal. If any one of these signals is lost, the LCD panel would be damaged.
 - h) The torque to mounting screw should never exceed 0.294 N·m (3 kgf·cm).
 - i) Don't push or rub the surface of LCD module.
If you do, the scratches or rubbing marks may be left there.
- (3) Cautions for the atmosphere
 - a) Dew drop atmosphere should be avoided.
 - b) Do not store and/or operate the LCD module in a high temperature and/or high humidity atmosphere. Storage in an electro-conductive polymer packing pouch and under relatively low temperature atmosphere is recommended.
 - c) This module uses cold cathod fluorescent lamp. Therefore, the life time of the lamp becomes short if the module is operated in the low temperature environment.
 - d) Do not operate the LCD module in a high magnetic field.
- (4) Caution for the module characteristics
 - a) Do not apply fixed pattern data signal for a long time to the LCD module. It may cause image sticking. Please use screen savers if the display pattern is fixed more than one hour.

(5) Other cautions

- a) Do not disassemble and/or reassemble LCD module.
- b) Do not readjust variable resistors etc.
- c) When returning the module for repair or etc, please pack the module not to be broken. We recommend to the original shipping packages.

Liquid Crystal Display has the following specific characteristics. There are not defects or malfunctions.

- The display condition of LCD module may be affected by the ambient temperature.
- The LCD module uses cold cathode tube for backlighting. Optical characteristics, like luminance or uniformity, will change during time.
- Uneven brightness and/or small spots may be noticed depending on different display patterns.

OUTLINE DRAWING: Rear View (Unit: mm)

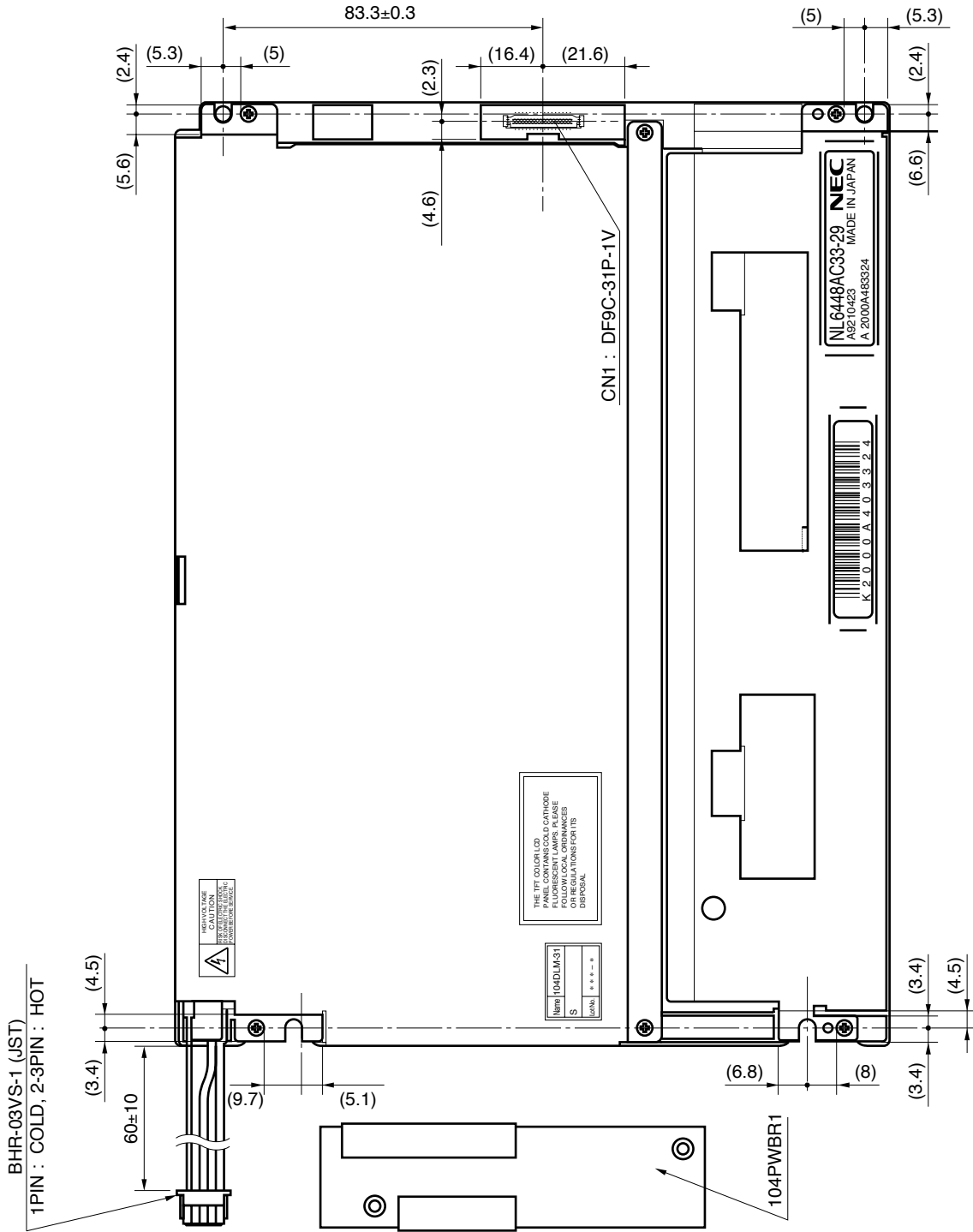

[MEMO]

[MEMO]

[MEMO]

No part of this document may be copied or reproduced in any form or by any means without the prior written consent of NEC Corporation. NEC Corporation assumes no responsibility for any errors which may appear in this document.

NEC Corporation does not assume any liability for infringement of patents. Copyrights or other intellectual property rights of third parties by or arising from use of a device described herein or any other liability arising from use of such device. No license, either express, implied or otherwise, is granted under any patents, copyrights or other intellectual property rights of NEC Corporation or others.

While NEC Corporation has been making continuous effort to enhance the reliability of its Electronic Components, the possibility of defects cannot be eliminated entirely. To minimize risks of damage or injury to persons or property arising from a defect in an NEC Electronic Components, customers must incorporate sufficient safety measures in its design, such as redundancy, fire-containment, and anti-failure features.

NEC devices are classified into the following three quality grades:

“Standard”, “Special”, and “Specific”. The Specific quality grade applies only to devices developed based on a customer designated “quality assurance program” for a specific application. The recommended applications of a device depend on its quality grade, as indicated below. Customers must check the quality grade of each device before using it in a particular application.

Standard: Computers, office equipment, communications equipment, test and measurement equipment, audio and visual equipment, home electronic appliances, machine tools, personal electronic equipment and industrial robots

Special: Transportation equipment (automobiles, trains, ships, etc.), traffic control systems, anti-disaster systems, anti-crime systems, safety equipment and medical equipment (not specifically designed for life support)

Specific: Aircrafts, aerospace equipment, submersible repeaters, nuclear reactor control systems, life support systems or medical equipment for life support, etc.

The quality grade of NEC devices is “Standard” unless otherwise specified in NEC’s Data Sheets or Data Books. If customers intend to use NEC devices for applications other than those specified for Standard quality grade, they should contact an NEC sales representative in advance.

Anti-radioactive design is not implemented in this product.

This datasheet has been download from:

www.datasheetcatalog.com

Datasheets for electronics components.