

# mass integrated

global part distribution • product lifecycle partner  
excess inventory management • value-ad service provider



Data sheet provided by Mass Integrated

[massintegrated.com](http://massintegrated.com) • [displayalliance.com](http://displayalliance.com)

Please call +1.978.465.6190  
Email: [sales@massintegrated.com](mailto:sales@massintegrated.com)



ISO 9001: 2008

Mass Integrated complies with all DMCA takedown notices. Please send a formal DMCA Takedown Notice to Mass Integrated Systems, Inc. • 18 Henry Graf Jr. Road, Unit 1 • Newburyport, MA 01950.

**31 cm (12.1 inches), 800 × 600 pixels, 262144 colors  
High luminance, Wide viewing angle, Reversible scan direction**

**DESCRIPTION**

NL8060BC31-17 is a TFT (thin film transistor) active matrix color liquid crystal display (LCD) module comprising amorphous silicon TFT attached to each signal electrode, a driving circuit, and a backlight.

NL8060BC31-17 has a built-in backlight. The backlight includes long-life-lamps and the lamps are replaceable with a holder.

The 31 cm diagonal display area contains 800 × 600 pixels and can display 262144 color simultaneously.

NL8060BC31-17 is suitable for industrial application use, because the viewing angle is wide and the luminance is high. Also, the viewing direction is selectable either upper or lower side by changing scan direction.

**FEATURES**

- High luminance (350 cd/m<sup>2</sup>, at I<sub>L</sub>= 5mAmps/lamp)
- Wide viewing angle (with Retardation film)
- Low reflection
- Reversible scan direction
- 6-bit digital RGB input signals
- Data enable (DE) function
- Smooth polarizer surface (no antiglare treatment)
- Edge type backlight with two long-life-time lamps (one lamp holder)
- Lamp holder replaceable

**APPLICATIONS**

- Display terminals for control system
- Monitors for process controller

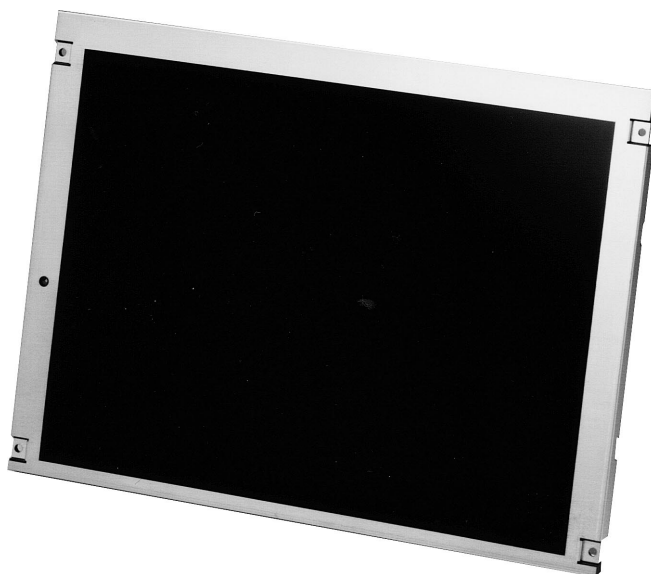

The information in this document is subject to change without notice.  
Please confirm with the delivery specification before starting to design the system.

**STRUCTURE AND FUNCTIONS**

A color TFT (thin film transistor) LCD module is comprised of a TFT liquid crystal panel structure, LSIs for driving the TFT array, and a backlight assembly. The TFT panel structure is created by sandwiching liquid crystal material in the narrow gap between a TFT array glass substrate and a color filter glass substrate. After the driver LSIs are connected to the panel, the backlight assembly is attached to the backside of the panel.

RGB (red, green, blue) data signals from a source system is modulated into a form suitable for active matrix addressing by the onboard signal processor and sent to the driver LSIs which in turn addresses the individual TFT cells.

Acting as an electro-optical switch, each TFT cell regulates light transmission from the backlight assembly when activated by the data source. By regulating the amount of light passing through the array of red, green, and blue dots, color images are created with clarity.

**OUTLINE OF CHARACTERISTICS (at room temperature)**

Item	Description
Display area	246.0 (H) × 184.5 (V) mm
Drive system	a-Si TFT active matrix
Display colors	262,144 colors
Number of pixels	800 × 600 pixels
Pixel arrangement	RGB vertical stripe
Pixel pitch	0.3075 (H) × 0.3075 (V) mm
Module size	280.0 (H) × 210.0 (V) × 13.0 (D) mm (typ.)
Weight	750 (typ.)
Contrast ratio	350:1 (typ.)
Viewing angle (more than the contrast ratio of 10:1)	Horizontal: 55° (typ. left side, right side) Vertical: 40° (typ. up side), 50° (typ. down side)
Designed viewing direction	<ul style="list-style-type: none"> <li>• Wider viewing angle with contrast ratio : down side (6 o'clock, normal scan) up side (12 o'clock, reverse scan)</li> <li>• Wider viewing angle without image reversal: up side (12 o'clock, normal scan) down side (6 o'clock, reverse scan)</li> <li>• Optimum grayscale (<math>\gamma = 2.2</math>) : perpendicular</li> </ul>
Color gamut	43% (typ. at center, to NTSC)
Response time	15 ms (typ.), "white 100%" to "black 10%"
Luminance	350 cd/m <sup>2</sup> (typ.) (Lamp current: I <sub>L</sub> = 5 mArms per lamp)
Signal system	6-bit signals for each of RGB primary colors, synchronous signals (Hsync, Vsync), dot clock (CLK)
Supply voltage	3.3 V [5.0 V] (Logic, LCD driving)
Backlight	Edge light type, two cold cathode fluorescent lamp in a holder <ul style="list-style-type: none"> <li>• Lamp holder : Part No.121LHS15</li> <li>• Recommended inverter: Part No. 121PW111</li> </ul>
Power consumption	7.0 W (typ. at 3.3 V, with a recommended inverter)

**BASIC STRUCTURE**

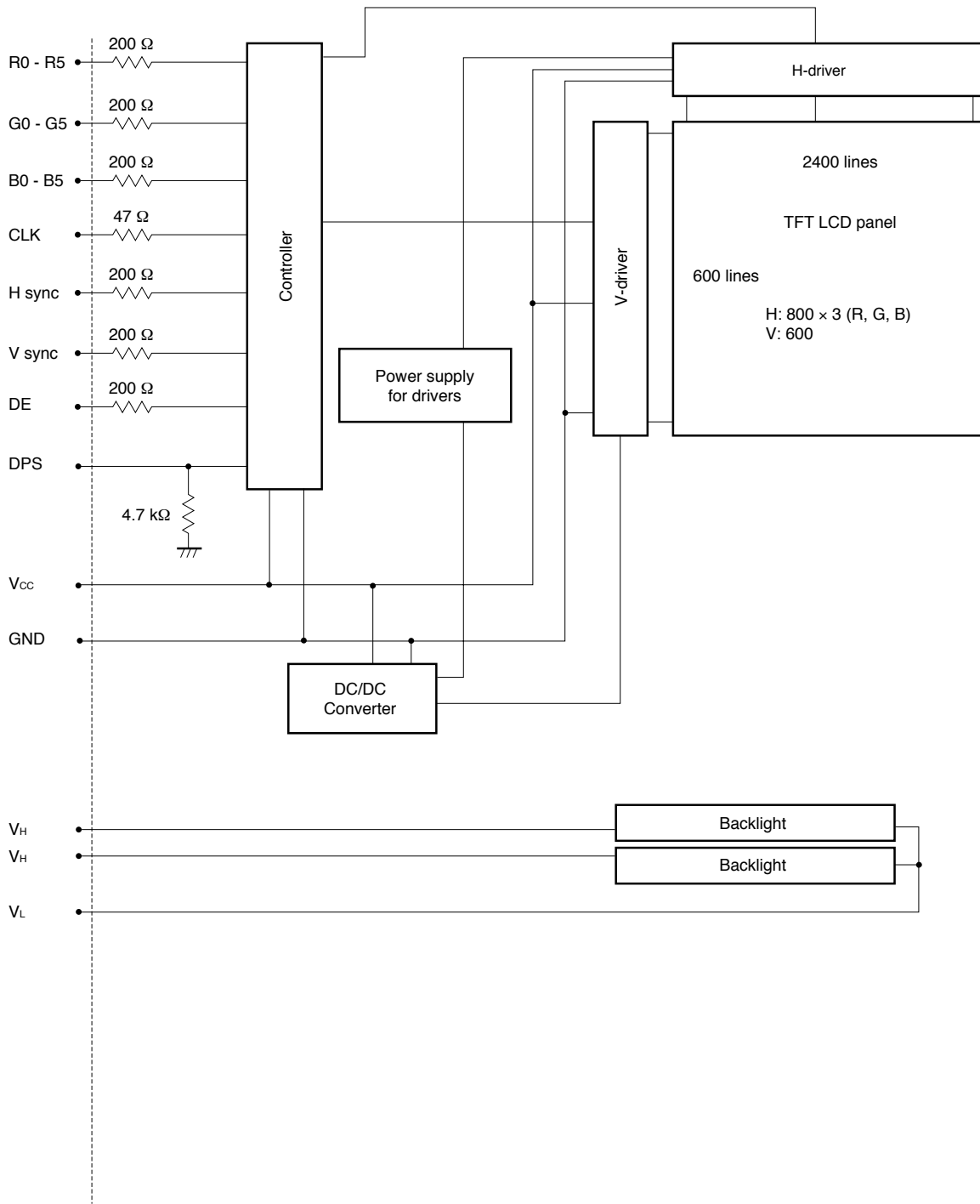

**Note 1:** GND is not connected to FG (Frame Ground) in the LCD module.

**GENERAL SPECIFICATIONS**

Item	Specification	Unit
Module size	280.0 ± 0.5 (H) × 210.0 ± 0.5 (V) × 13.7 max. (D)	mm
Display area	246.0 (H) × 184.5 (V) [Diagonal display area: 31 cm (Type 12.1)]	mm
Number of pixels	800 × 3 (H) × 600 (V)	pixel
Dot pitch	0.1025 (H) × 0.3075 (V)	mm
Pixel pitch	0.3075 (H) × 0.3075 (V)	mm
Pixel arrangement	RGB (Red, Green, Blue) vertical stripe	-
Display colors	262,144	color
Weight	780 (max.)	g

**ABSOLUTE MAXIMUM RATINGS**

Parameter	Symbol	Rating	Unit	Remarks	
Supply voltage	V <sub>CC</sub>	-0.3 to 6.5	V	T <sub>a</sub> = 25°C	
Input voltage	V <sub>i</sub>	-0.3 to V <sub>CC</sub> + 0.3	V		
Lamp voltage	V <sub>L</sub>	1800	V <sub>rms</sub>		
Storage temp.	T <sub>ST</sub>	-20 to 60	°C	-	
Operating temp.	T <sub>OP</sub>	0 to 50	°C	Module surface*	
Relative Humidity (RH)		≤ 95	%	T <sub>a</sub> ≤ 40°C	No condensation
		≤ 85	%	40 < T <sub>a</sub> ≤ 50°C	
Absolute humidity		Absolute humidity shall not exceed T <sub>a</sub> = 50°C, RH=85%	g/m <sup>3</sup>	T <sub>a</sub> > 50°C	

\* Measured at the panel surface (including self-heat)

**ELECTRICAL CHARACTERISTICS**

**(1) Logic LCD driving**

T<sub>a</sub> = 25°C

Parameter	Symbol	Min.	Typ.	Max.	Unit	Remarks
Supply voltage	V <sub>CC</sub>	3.0 (4.75)	3.3 (5.0)	3.6 (5.25)	V	V <sub>CC</sub> = 3.3 V (V <sub>CC</sub> = 5.0 V)
Logic input "L" voltage	V <sub>IL</sub>	0	-	V <sub>CC</sub> × 0.3	V	CMOS level
Logic input "H" voltage	V <sub>IH</sub>	V <sub>CC</sub> × 0.7	-	V <sub>CC</sub>	V	
Supply current	I <sub>CC</sub>	- -	* 320 (240)	600 (500)	mA	V <sub>CC</sub> = 3.3 V (V <sub>CC</sub> = 5.0 V)

\* Checker flag pattern (in EIAJ ED-2522)



**INTERFACE AND CONNECTOR PIN ASSIGNMENT**

**(1) Interface signals, power supply**

CN1: DF9-41P-1V (HIROSE ELECTRIC CO., LTD.)

Adaptable socket: DF9-41S-1V (HIROSE ELECTRIC CO., LTD.)

or

IL-310-T41S-VF (Japan Aviation Electronics Industry Limited (JAE))

Pin No.	Symbol	Function
1	GND	Ground
2	CLK	Dot clock
3	GND	Ground
4	Hsync	Horizontal sync.
5	Vsync	Vertical sync.
6	GND	Ground
7	GND	Ground
8	GND	Ground
9	R0	Red data (LSB)
10	R1	Red data
11	R2	Red data
12	GND	Ground
13	R3	Red data
14	R4	Red data
15	R5	Red data (MSB)
16	GND	Ground
17	GND	Ground
18	GND	Ground
19	G0	Green data (LSB)
20	G1	Green data
21	G2	Green data

Pin No.	Symbol	Function
22	GND	Ground
23	G3	Green data
24	G4	Green data
25	G5	Green data (MSB)
26	GND	Ground
27	GND	Ground
28	GND	Ground
29	B0	Blue data (LSB)
30	B1	Blue data
31	B2	Blue data
32	GND	Ground
33	B3	Blue data
34	B4	Blue data
35	B5	Blue data (MSB)
36	GND	Ground
37	DE	Data enable signal
38	N.C.	Not Connection
39	V <sub>CC</sub>	Power supply <b>Note 1</b>
40	V <sub>CC</sub>	Power supply <b>Note 1</b>
41	DPS	Scan direction select <b>Note 2</b>

LSB : Least Significant Bit  
MSB : Most Significant Bit

**Notes 1.** DE/This function recognizes Fixed or DE mode whe Vsync rises.

- Low = DE mode
- High = Fixed mode

**Notes 2.** DPS/DPS changes scan direction (normal scan and reverse scan).

- Low or Open = Normal scan
- High = Reverse scan

See DISPLAY POSITION about the scan directions.

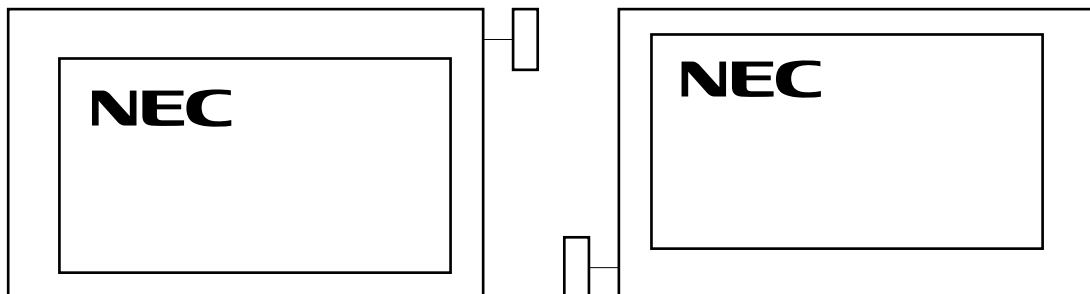

**(2) Lamp connector**

CN2: BHR-03VS-1  
 Adaptable socket: SM03 (4.0) B-BHS-TB  
 Supplier: J.S.T TRADING COMPANY, LTD.

Pin No.	Symbol	Function
1	V <sub>L</sub>	Low voltage terminal
2	V <sub>H</sub>	High voltage terminal
3	V <sub>H</sub>	High voltage terminal

\* V<sub>H</sub> and V<sub>L</sub> must be connected correctly. If you make a mistake to connect, you will get hurt and the module will break.

**(3) Connection of recommended Inverter: 121PW111**

CN1  
 Part No.: LZ-5P-SL-SMT  
 Adaptable socket: LZ-5S-SC3  
 Supplier: Japan Aviation Electronics Industry Limited (JAE)

Pin No.	Symbol	Function
1	V <sub>DDB</sub>	Power supply (12 V)
2	V <sub>DDB</sub>	Power supply (12 V)
3	GNDB	Backlight ground
4	GNDB	Backlight ground
5	BRTHL	Luminance control <b>Note 1</b>

**Note 1:** BRTHL = High (+5 V) or open : High luminance (100%)  
 BRTHL = Low (GNDB level) : Low luminance (20%)

CN3  
 Part No.: IL-Z-3PL-SMTY  
 Adaptable socket: IL-Z-3S-S125C3  
 Supplier: Japan Aviation Electronics Industry Limited (JAE)

Pin No.	Symbol	Function
1	BRTC	Backlight ON/OFF signal <b>Note 1</b>
2	BRTH	Luminance control input <b>Note 2</b>
3	BRTL	Luminance control input <b>Note 2</b>

**Notes 1.** BRTC = High (+5 V) or Open : Backlight "ON"  
 BRTC = Low (GNDB level) : Backlight "OFF"

2. <1> A way of luminance control by a variable resistor.  
 This way works when BRTHL (No.5 pin) of CN1 is opened.

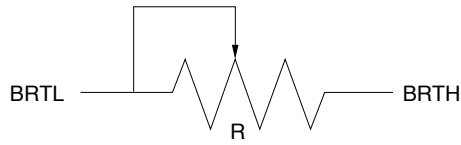

Mating variable resistor : 10 kΩ ±5 %  
 Minimum luminance (20%) : R = 0 Ω  
 Maximum luminance (100%): R = 10 kΩ

- <2> A way of luminance control by a voltage  
 BRTL and BRTHL are opened. The range of input voltage between BRTH and GNDB is as follows.

Minimum luminance (20%, typ.) : 3.45 V  
 Maximum luminance (100%) : ≤ 1.0 V

(4) Connector location

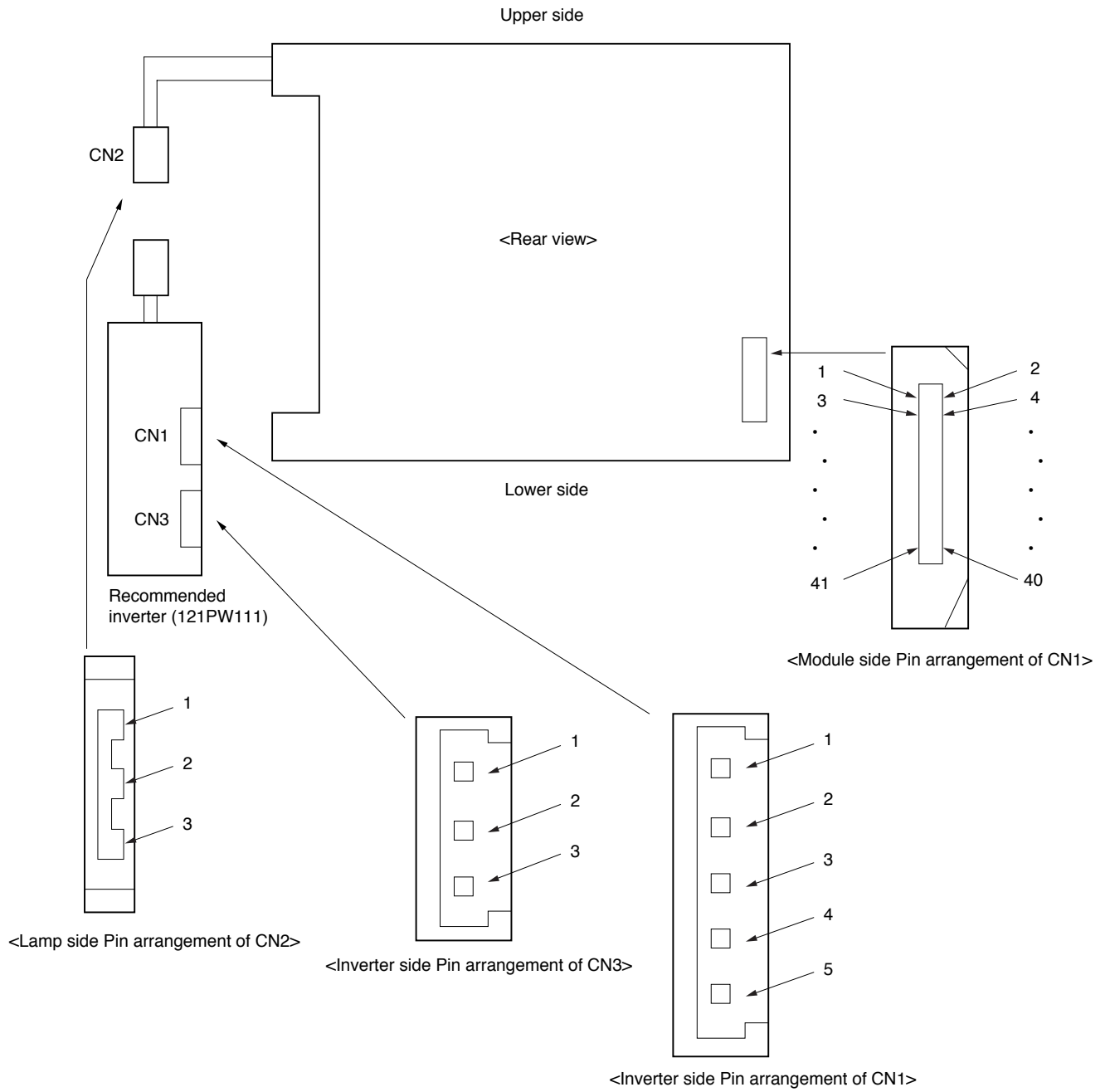

DISPLAY COLORS vs. INPUT DATA SIGNALS

Display colors		Data signal (0: Low level, 1: High level)																	
		R5	R4	R3	R2	R1	R0	G5	G4	G3	G2	G1	G0	B5	B4	B3	B2	B1	B0
Basic colors	Black	0	0	0	0	0	0	0	0	0	0	0	0	0	0	0	0	0	0
	Blue	0	0	0	0	0	0	0	0	0	0	0	0	1	1	1	1	1	1
	Red	1	1	1	1	1	1	0	0	0	0	0	0	0	0	0	0	0	0
	Magenta	1	1	1	1	1	1	0	0	0	0	0	0	1	1	1	1	1	1
	Green	0	0	0	0	0	0	1	1	1	1	1	1	0	0	0	0	0	0
	Cyan	0	0	0	0	0	0	1	1	1	1	1	1	1	1	1	1	1	1
	Yellow	1	1	1	1	1	1	1	1	1	1	1	1	0	0	0	0	0	0
	White	1	1	1	1	1	1	1	1	1	1	1	1	1	1	1	1	1	1
Red grayscale	Black	0	0	0	0	0	0	0	0	0	0	0	0	0	0	0	0	0	0
	Dark	0	0	0	0	0	1	0	0	0	0	0	0	0	0	0	0	0	0
	↑																		
	↓																		
	Bright	1	1	1	1	0	1	0	0	0	0	0	0	0	0	0	0	0	0
	Red	1	1	1	1	1	0	0	0	0	0	0	0	0	0	0	0	0	0
Green grayscale	Black	0	0	0	0	0	0	0	0	0	0	0	0	0	0	0	0	0	0
	Dark	0	0	0	0	0	0	0	0	0	1	0	0	0	0	0	0	0	0
	↑																		
	↓																		
	Bright	0	0	0	0	0	0	1	1	1	1	0	1	0	0	0	0	0	0
	Green	0	0	0	0	0	0	1	1	1	1	1	1	0	0	0	0	0	0
Blue grayscale	Black	0	0	0	0	0	0	0	0	0	0	0	0	0	0	0	0	0	0
	Dark	0	0	0	0	0	0	0	0	0	0	0	0	0	0	0	0	1	0
	↑																		
	↓																		
	Bright	0	0	0	0	0	0	0	0	0	0	0	0	1	1	1	1	0	1
	Blue	0	0	0	0	0	0	0	0	0	0	0	0	1	1	1	1	1	0
	Blue	0	0	0	0	0	0	0	0	0	0	0	1	1	1	1	1	1	

**Note** Colors are developed in combination with 6-bit signals (64 steps in grayscale) of each primary red, green, and blue color.

This process can result in up to 262144 (64 × 64 × 64) colors.

**INPUT SIGNAL TIMING**

**(1) Input signal specifications**

Parameter		Symbol	Min.	Typ.	Max.	Unit	Remarks
CLK	Frequency	1/tc	34.0	38.362	40.0	MHz	26.067 ns (typ.)
	Duty	tch/tc	0.4	0.5	0.6	-	-
	Rise, fall	tcrf	-	-	10	ns	-
Hsync	Period	th	24.3	26.693	-	μs	37.468 kHz (typ.)
			829	1024	-	CLK	
	Display period	thd	800			CLK	-
	Front-porch	thf	-	24	-	CLK	Fixed mode
			4	24	-	CLK	DE mode
	Pulse width	thp	12	72	127	CLK	Fixed mode
			12	72	-	CLK	DE mode
	Back-porch	thb	73	128	198	CLK	Fixed mode
			13	128	509	CLK	DE mode
	thp + thb		200			CLK	Fixed mode
			25	200	511	CLK	DE mode
	CLK-Hsync timing	thch	10	-	-	ns	-
	Hsync-CLK timing	thcs	8	-	-	ns	-
	Hsync-Vsync timing	thv	1	-	-	CLK	-
Vsync-Hsync timing	tvh	15	-	-	ns	-	
Rise, fall	thrf	-	-	10	ns	-	
Vsync	Period	tv	16.1	16.683	17.2	ms	59.95 Hz (typ.)
			603	625	-	H	
	Display period	tvd	600			H	
	Front-porch	tvf	-	1	-	H	Fixed mode
			1	1	-	H	DE mode
	Pulse width	tvp	1	2	23	H	Fixed mode
			1	2	-	H	DE mode
	Back-porch	tvb	1	22	23	H	Fixed mode
			1	22	-	H	DE mode
	tvp + tvb		24			H	Fixed mode
2			24	254	H	DE mode	
Rise, fall	tvrf	-	-	10	ns	-	
DATA R0 – R5 G0 – G5 B0 – B5	CLK-DATA timing	tds	8	-	-	ns	-
	DATA-CLK timing	tdh	10	-	-	ns	-
	Rise, fall	tdrf	-	-	10	ns	-
DE	DE-CLK timing	tes	8	-	-	ns	-
	CLK-DE timing	teh	10	-	-	ns	
	Rise, fall	terf	-	-	10	ns	

\* All of parameters should be kept in the specified range.

(2) Definition of input signal timing

<Vertical>

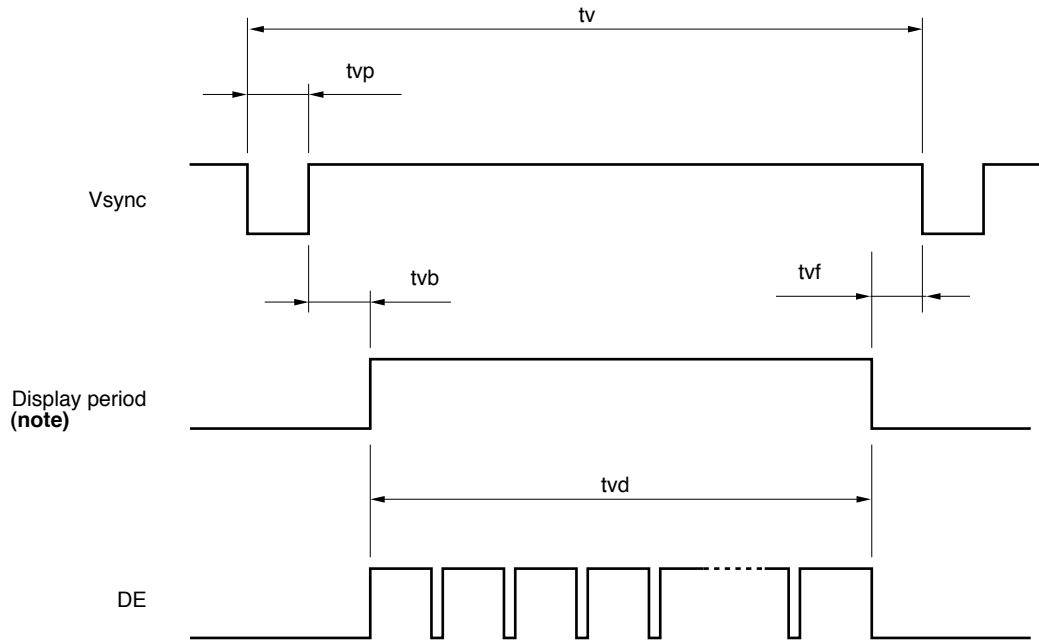

<Horizontal>

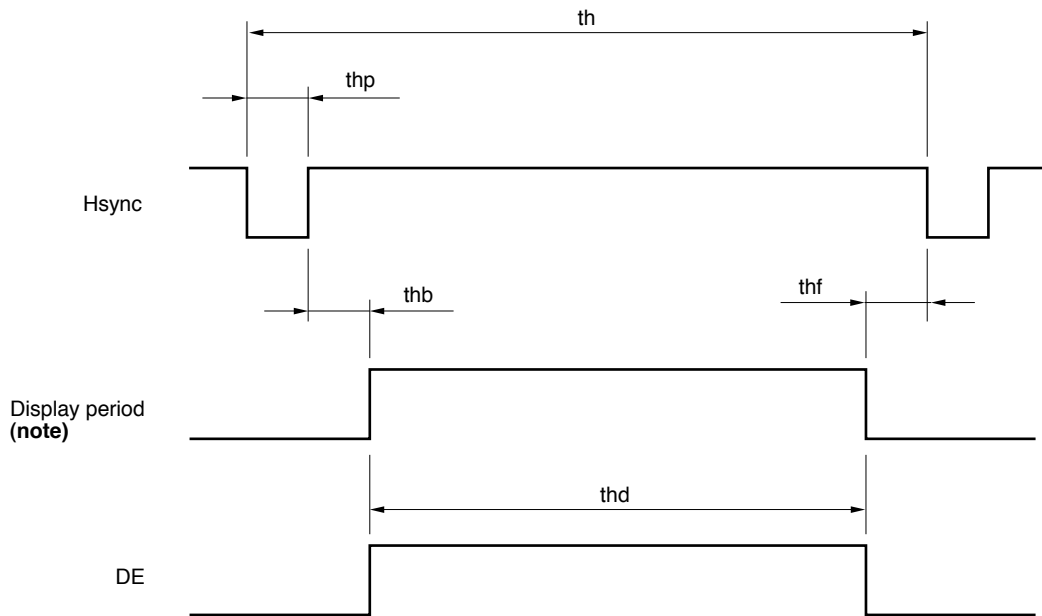

**Note** These do not exist as signals.

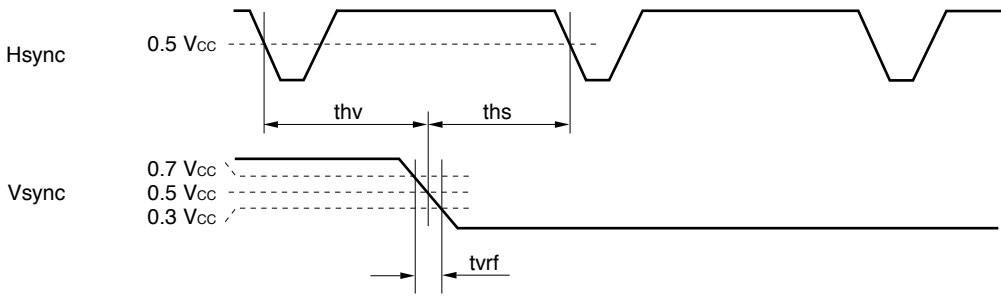
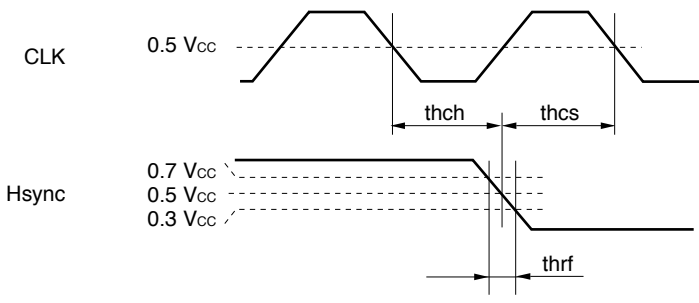
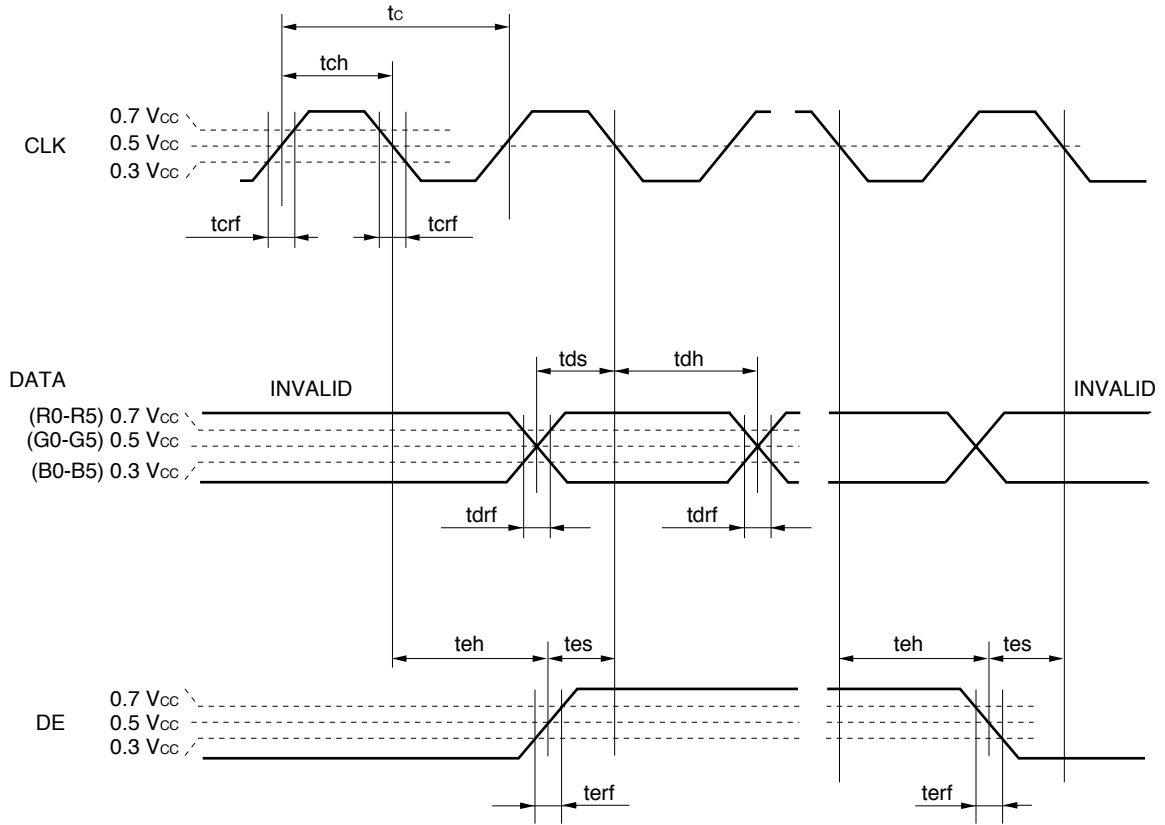

(3) Input signal timing chart

a) Fixed timing mode

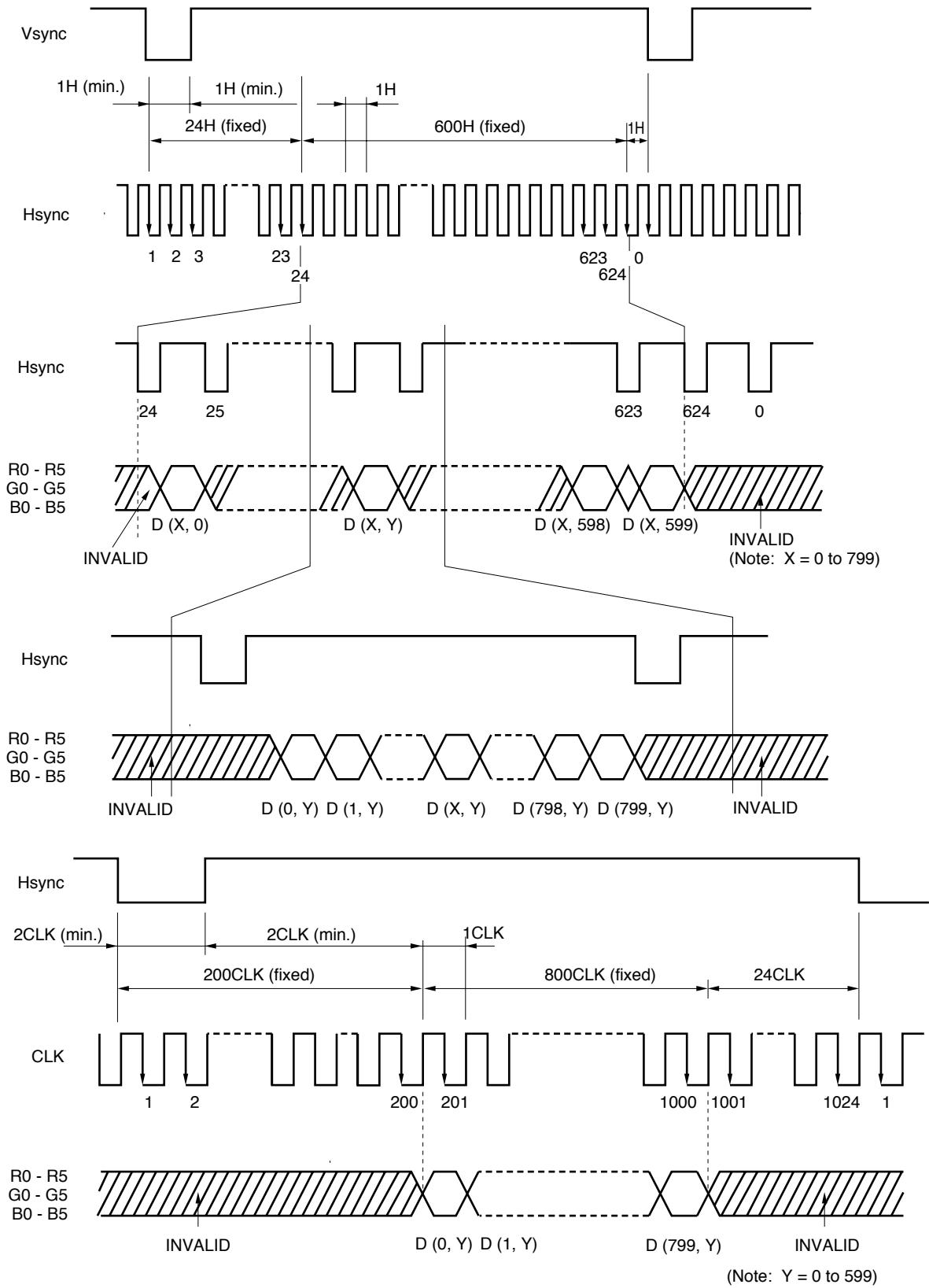

b) DE mode

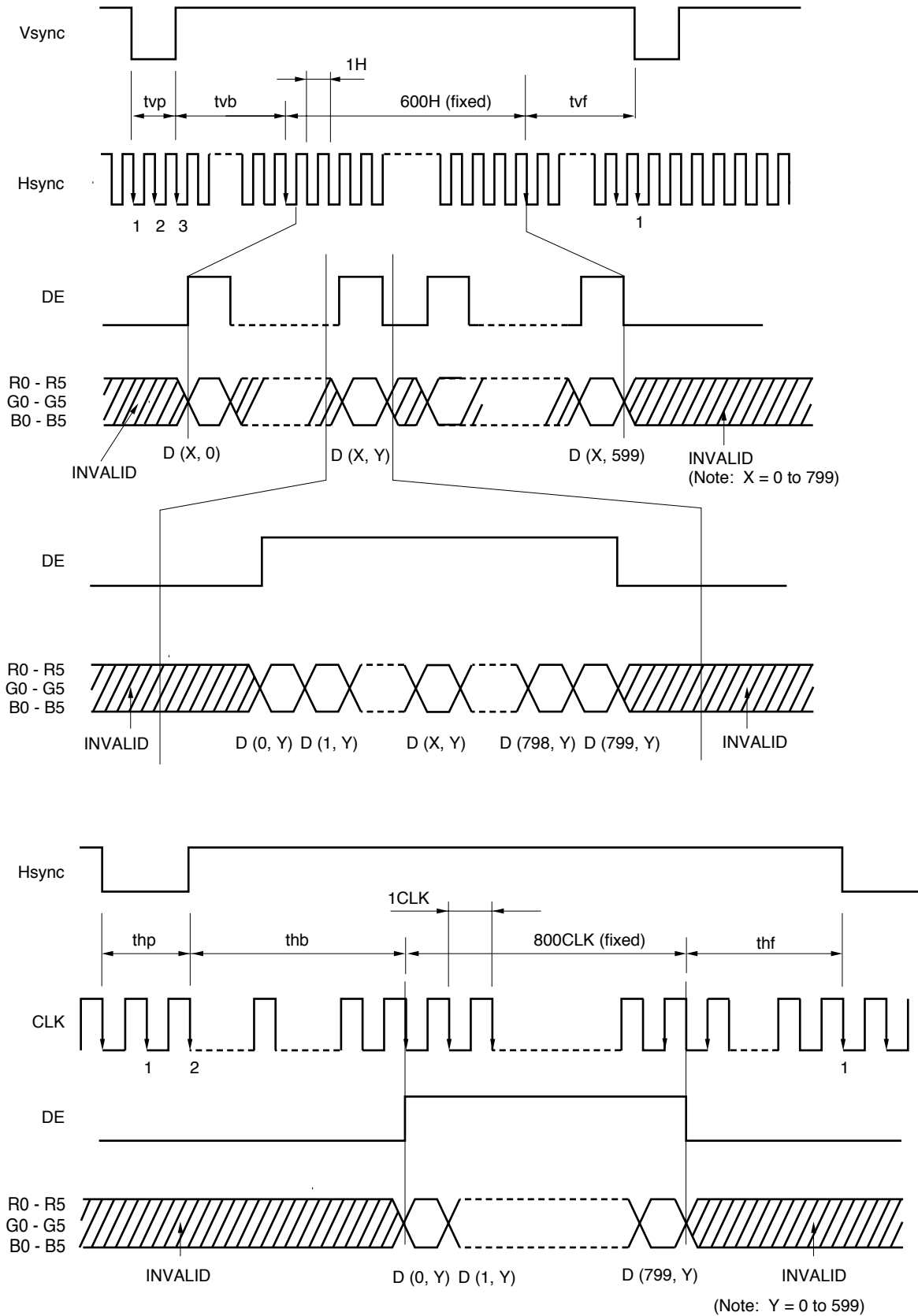

DISPLAY POSITION

Normal scan (DPS = "Low" or "Open")

D (0, 1)	D (1, 1)	-----	D (X, 1)	-----	D (798, 1)	D (799, 1)
D (0, 1)	D (1, 1)	-----	D (X, 1)	-----	D (798, 1)	D (799, 1)
		-----		-----		
D (0, Y)	D (1, Y)	-----	D (X, Y)	-----	D (798, Y)	D (799, Y)
		-----		-----		
D (0, 598)	D (1, 598)	-----	D (X, 598)	-----	D (798, 598)	D (799, 598)
D (0, 599)	D (1, 599)	-----	D (X, 599)	-----	D (798, 599)	D (799, 599)

Reverse scan (DPS = "High")

D (799,599)	D (798,599)	-----	D (X, 599)	-----	D (1,599)	D (0,599)
D (799,598)	D (798,598)	-----	D (X, 598)	-----	D (1,598)	D (0,598)
		-----		-----		
D (799, Y)	D (798, Y)	-----	D (X, Y)	-----	D (1, Y)	D (0, Y)
		-----		-----		
D (799, 1)	D (798, 1)	-----	D (X, 1)	-----	D (1, 1)	D (0, 1)
D (799, 0)	D (798, 0)	-----	D (X, 0)	-----	D (1, 0)	D (0, 0)

\* Below drawings show relations between the scan direction and the viewing direction.

Normal scan

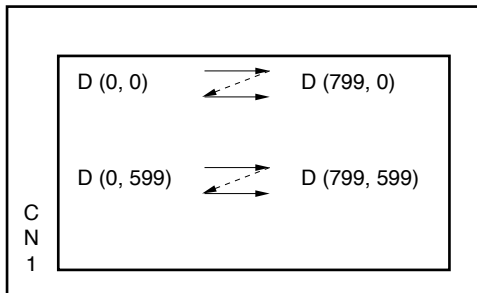

Reverse scan

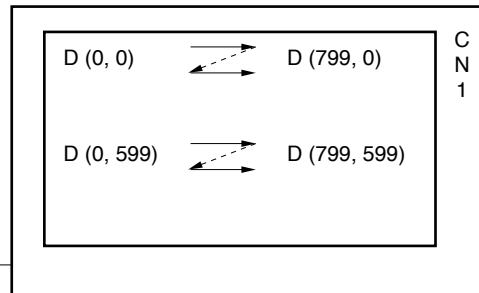

OPTICAL CHARACTERISTICS

Ta = 25°C Note 1

Item	Symbols	Conditions	Min.	Typ.	Max.	Unit	Remarks
Contrast ratio	CR	Note 2	200	350	-	-	Note 3
Luminance	Lumax.	Note 2	270	350	-	cd/m <sup>2</sup>	Note 4
Luminance uniformity	-	max./min.	-	-	1.4	-	Note 5

Reference data

Item	Symbols	Conditions	Min.	Typ.	Max.	Unit	Remarks	
Color gamut	C	at center, to NTSC	35	43	-	%	-	
Viewing angle range	Horizontal	$\theta_{x+}$	CR > 10, $\theta_y = \pm 0^\circ$	45	55	-	deg.	Note 7
		$\theta_{x-}$	CR > 10, $\theta_y = \pm 0^\circ$	45	55	-	deg.	
	Vertical	$\theta_{y+}$	CR > 10, $\theta_x = \pm 0^\circ$	30	40	-	deg.	
		$\theta_{y-}$	CR > 10, $\theta_x = \pm 0^\circ$	40	50	-	deg.	
Response time	t on	White to black 100% → 10%	-	15	40	ms	Note 6	
	t off	Black to white 0% → 90%	-	55	70	ms		

Notes 1. V<sub>cc</sub> = 3.3 V, I<sub>L</sub> = 5.0 mA rms, with recommended inverter Part No. 121PW111.

- 2. Viewing angle:  $\theta_x = \pm 0^\circ$ ,  $\theta_y = \pm 0^\circ$ , At center.
- 3. The contrast ratio is calculated by using the following formula.

$$\text{Contrast ratio (CR)} = \frac{\text{Luminance with all pixels in "white"}}{\text{Luminance with all pixels in "black"}}$$

The luminance is measured in darkroom.

- 4. The luminance is measured after 20 minutes from the module works, with all pixels in "white". Typical value is measured after luminance saturation. The luminance is measured in darkroom.

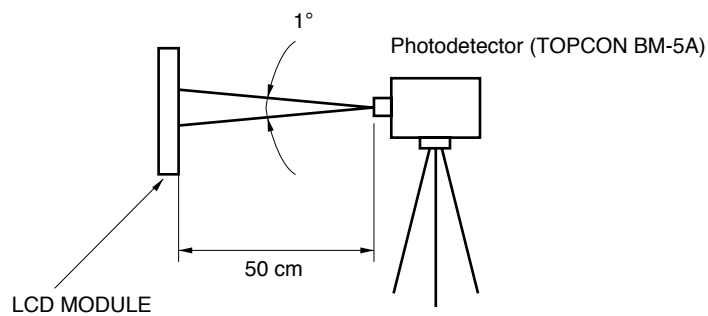

5. The luminance uniformity is calculated by using following formula.

$$\text{Luminance uniformity} = \frac{\text{Maximum luminance}}{\text{Minimum luminance}}$$

The luminance is measured at near the five points shown below.

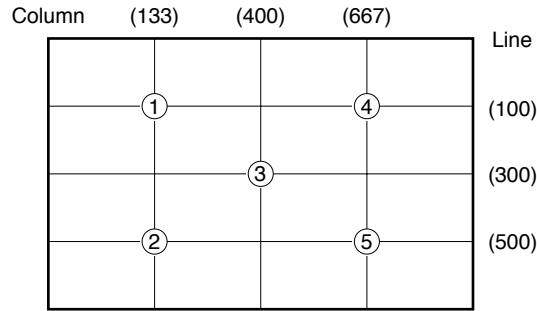

6. Definition of response time is as follows.

Photodetector output signal is measured when the Luminance changes "white" to "black" or "black" to "white".

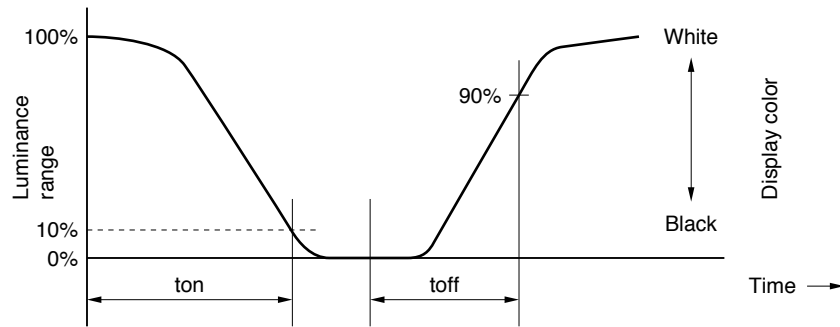

7. Definitions of viewing angle are as follows.

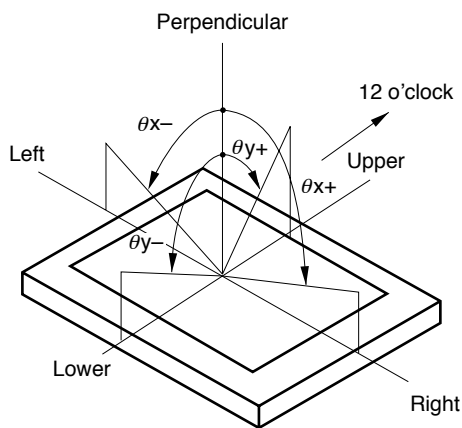

**RELIABILITY TEST SPECIFICATIONS**

Test items	Test conditions	Judgement
High temperature/humidity operation	50 ±2°C, 85% relative humidity 240 hours Display data is black.	<b>Note 1</b>
Heat cycle (operation)	<1> 0°C ±3°C ... 1 hour 55°C ±3°C ... 1 hour <2> 50 cycles, 4 hours/cycle <3> Display data is black.	<b>Note 1</b>
Thermal shock (non-operation)	<1> -20°C ±3°C ... 30 minutes 60°C ±3°C ... 30 minutes <2> 100 cycles <3> Temperature transition time within 5 minutes	<b>Note 1</b>
Vibration (non-operation)	<1> 5 - 100 Hz, 19.6 m/s <sup>2</sup> (2G) 1 minute/cycle, X, Y, Z direction <2> 120 times each direction	<b>Note 1</b> <b>Note 2</b>
Mechanical shock (non-operation)	<1> 539 m/s <sup>2</sup> (55G), 11 ms X, Y, Z direction <2> 5 times each direction	<b>Note 1</b> <b>Note 2</b>
ESD (operation)	150 pF, 150 Ω, ±10 kV 9 places on a panel 10 times each place at one-second intervals	<b>Note 1</b> <b>Note 3</b>
Dust (operation)	15 kinds of dust (JIS Z 8901) Hourly 15 seconds stir, 8 times repeat	<b>Note 1</b>

- Notes 1.** Display function is checked by the same condition as LCD module out-going inspection.  
**2.** Physical damage.  
**3.** Discharge points are shown as follows.

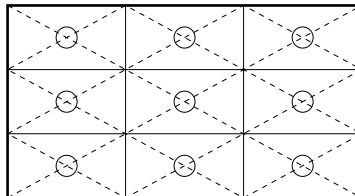



**GENERAL CAUTIONS**

Next figures and sentence are very important, please understand these contents as follows.

	<b>CAUTION</b>	This figure is a mark that you will get hurt and/or the module will have damages when you make a mistake to operate.
---	----------------	--

	This figure is a mark that you will get an electric shock when you make a mistake to operate.	
---	---	--

	This figure is a mark that you will get hurt when you make a mistake to operate	
---	---	--

 **CAUTION**

	Do not touch an inverter ...on which is stuck a caution label... while the LCD module is under the operation, because of dangerous high voltage.
---	--

(1) Caution when taking out the module

- <1> Pick the pouch only, when taking out the module from a carrier box.

(2) Cautions for handling the module

- <1> As the electrostatic discharges may break the LCD module, handle the LCD module with care against electrostatic discharges. Peel protection sheet cut from the LCD panel surface as slowly as possible.
- <2>  As the LCD panel and backlight element are made from fragile glass material, impulse and pressure to the LCD module should be avoided.
- <3> As the surface of polarizer is very soft and easily scratched, use a soft dry cloth without chemicals for cleaning.
- <4> Do not pull the interface connectors in or out while the LCD module is operating.
- <5> Put the module display side down on a flat horizontal plane.
- <6> Handle connectors and cables with care.
- <7> When the module is operating, do not lose CLK, Hsync, or Vsync signal. If any one of these signals is lost, the LCD panel would be damaged.
- <8> The torque for mounting screw should never exceed 0.294 N-m (3 kgf-cm).
- <9> Don't push or rub the surface of LCD module please.  
If you do, the scratches or the marks like rubbing marks may be left on the surface of the module.
- <10> Do not give the stress to interface connectors. The module may become function by a contact defective and damages. Pay attention to handling at the time of matching connector connection and in the connection condition.

(3) Cautions for the atmosphere

- <1> Dew drop atmosphere must be avoided.
- <2> Do not store and/or operate the LCD module in high temperature and/or high humidity atmosphere. Storage in an anti-static pouch and under the room temperature atmosphere is recommended.
- <3> This module uses cold cathod fluorescent lamps. Therefore, the life time of lamp becomes short if the module is operated under the low temperature environment.
- <4> Do not operate the LCD module in high magnetic field.

## (4) Caution for the module characteristics

- <1> Do not apply any fixed patterns data for a long time to the LCD module. It may cause image sticking. Please use screen savers if the display pattern is fixed for a long time.
- <2> This module has the retardation film which may cause the variation of the color hue in the different viewing angles. The ununiformity may appear on the screen under the high temperature operation.
- <3> The light vertical stripe may be observed depending on the display pattern. This is not defects or malfunctions.
- <4> The noise from the inverter circuit may be observed in the luminance control mode. This is not defects or malfunctions.

## (5) Other cautions

- <1> Do not disassemble and/or reassemble LCD module.
- <2> Do not readjust variable resistors nor switches etc.
- <3> When returning the module for repair etc., Please pack the module properly to avoid any damages. We recommend the original shipping packages.

Liquid Crystal Display has the following specific characteristics. There are not defects nor malfunctions.

The optical characteristics of this module may be affected by the ambient temperature.

The LCD module uses cold cathode tube for backlighting. Optical characteristics, like luminance or uniformity, will be changed by the progress in time.

Uneven brightness and/or small spots may be observed depending on different display patterns.

**OUTLINE DRAWING**  
FRONT SIDE (Unit in mm)

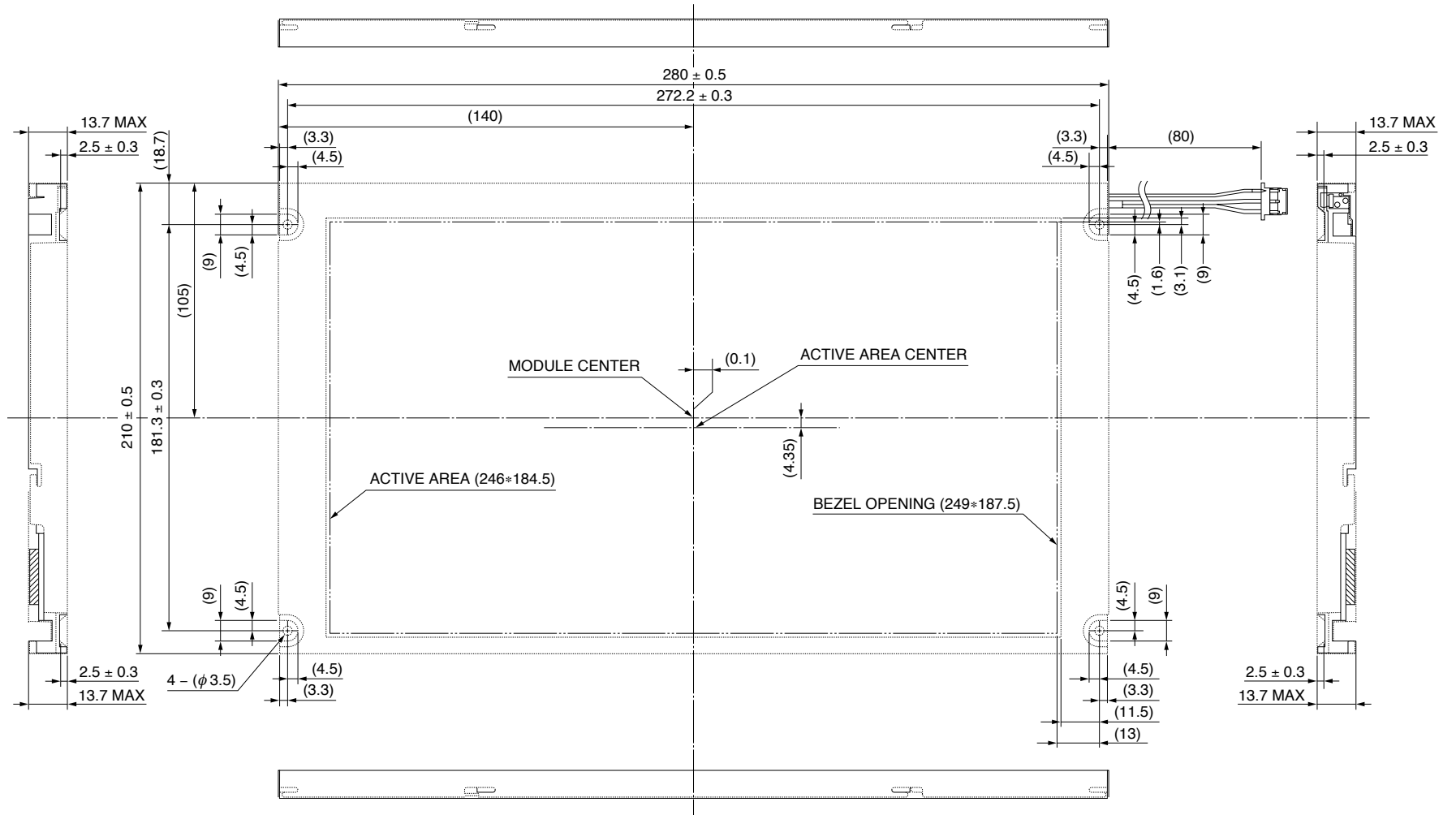

**Note 1:** The value in parentheses are for reference.

**Note 2:** The torque to mounting screw never exceed 0.294 N·m (3kgf·cm).

**OUTLINE DRAWING**  
 REAR SIDE (Unit in mm)

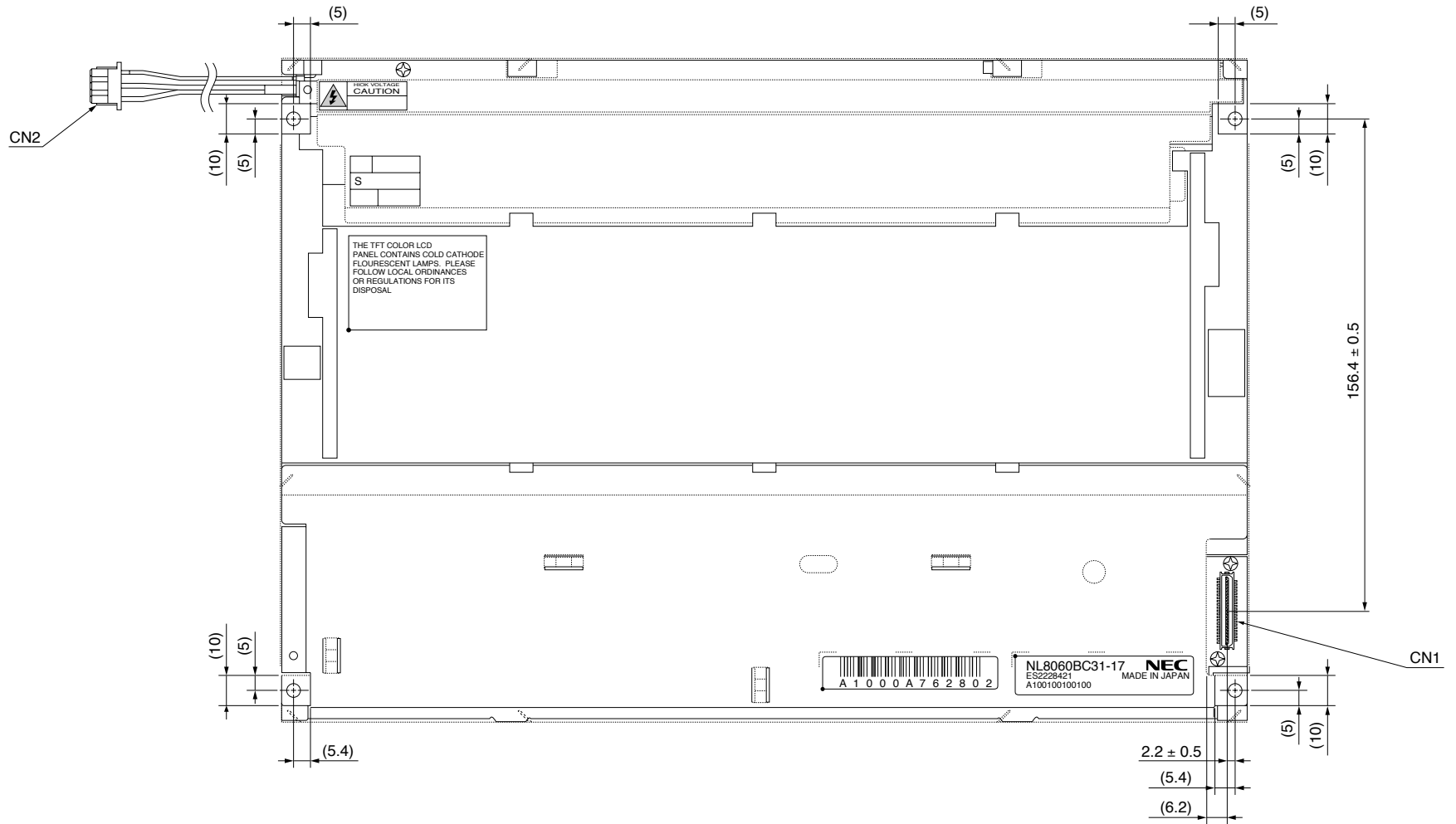

**Note 1:** The value in parentheses are for reference.

**Note 2:** The torque to mounting screw never exceed 0.294 N·m (3kgf·cm).

No part of this document may be copied in any form or by any means without the prior written consent of NEC Corporation.

NEC Corporation does not assume any liability for infringement of patents, copyrights or other intellectual property rights of third parties by or arising from use of a device described herein or any other liability arising from use of such device. No license, either express, implied or otherwise, is granted under any patents, copyrights or other intellectual property rights of NEC Corporation or of others.

While NEC Corporation has been making continuous effort to enhance the reliability of its Electronic Components, the possibility of defects cannot be eliminated entirely. To minimize risks of damage or injury to persons or property arising from a defect in an NEC Electronic Components, customers must incorporate sufficient safety measures in its design, such as redundancy, fire-containment, and anti-failure features.

NEC devices are classified into the following three quality grades:

"Standard", "Special", and "Specific". The Specific quality grade applies only to devices developed based on a customer designated "quality assurance program" for a specific application. The recommended applications of a device depend on its quality grade, as indicated below. Customers must check the quality grade of each device before using it in a particular application.

Standard: Computers, office equipment, communications equipment, test and measurement equipment, audio and visual equipment, home electronic appliances, machine tools, personal electronic equipment and industrial robots.

Special: Transportation equipment (automobiles, trains, ships, etc.), traffic control systems, anti-disaster systems, anti-crime systems, safety equipment and medical equipment (not specifically designed for life support)

Specific: Aircrafts, aerospace equipment, submersible repeaters, nuclear reactor control systems, life support systems or medical equipment for life support, etc.

The quality grade of NEC devices is "Standard" unless otherwise specified in NEC's Data Sheets or Data Books. If customers intend to use NEC devices for applications other than those specified for Standard quality grade, they should contact an NEC sales representative in advance.

Anti-radioactive design is not implemented in this product.

This datasheet has been download from:

[www.datasheetcatalog.com](http://www.datasheetcatalog.com)

Datasheets for electronics components.