

# mass integrated

global part distribution • product lifecycle partner  
excess inventory management • value-ad service provider



Data sheet provided by Mass Integrated

[massintegrated.com](http://massintegrated.com) • [displayalliance.com](http://displayalliance.com)

Please call +1.978.465.6190  
Email: [sales@massintegrated.com](mailto:sales@massintegrated.com)



ISO 9001: 2008

Mass Integrated complies with all DMCA takedown notices. Please send a formal DMCA Takedown Notice to Mass Integrated Systems, Inc. • 18 Henry Graf Jr. Road, Unit 1 • Newburyport, MA 01950.

Version:1.0

TECHNICAL SPECIFICATION  
MODEL NO : PM100WX6

The content of this information is subject to be changed without notice.  
Please contact PVI or its agent for further information.

Customer's Confirmation

Customer \_\_\_\_\_

Date \_\_\_\_\_

By \_\_\_\_\_

PVI's Confirmation

Confirmed By Zmyy Chang

Prepared By 曾耀廷

---

**Revision History**

<b>Rev.</b>	<b>Issued Date</b>	<b>Revised</b>	<b>Contents</b>
1.0	January,11,2008	New	

# TECHNICAL SPECIFICATION

## CONTENTS

<b>NO.</b>	<b>ITEM</b>	<b>PAGE</b>
-	Cover	1
-	Revision History	2
-	Contents	3
1	Application	4
2	Features	4
3	Mechanical Specifications	4
4	Mechanical Drawing of TFT-LCD module	6
5	Input / Output Terminals	7
6	Absolute Maximum Ratings	10
7	Electrical Characteristics	10
8	Pixel Arrangement	11
9	Display Color and Gray Scale Reference	12
10	Block Diagram	13
11	Interface Timing	14
12	Power On Sequence	19
13	Optical Characteristics	19
14	Handling Cautions	23
15	Reliability Test	24
16	Packing Diagram	25

## 1. Application

This data sheet applies to a color TFT LCD module, PM100WX6

PM100WX6 module applies to OA product, which requires high quality flat panel display. If you must use in severe reliability environment, please don't extend over PVI's reliability test conditions.

If you use PM100WX6, Prime View advises your systems use PVI's timing controller IC (PVI-2003A) which will generate proper timing signals to control PM100WX6.

## 2. Features

- . Wide VGA 800×(R, G, B)×480 dots resolution
- . Pixel in stripe configuration
- . Thin and light weight
- . Display Colors : 262,144 colors
- . Gray scale inversion Direction : 6 o'clock
- . TTL interface

## 3. Mechanical Specifications

Parameter	Specifications	Unit
Screen Size	10 (diagonal)	inch
Display Format	800×(R, G, B)×480	dot
Display Colors	262,144	
Active Area	216.0(H)×129.6(V)	mm
Pixel Pitch	0.270(H)×0.270(V)	mm
Pixel Configuration	Stripe	
Outline Dimension	232.0(W)×144.6 (H)×6.5 (D) (typ.)	mm
Weight	330±10	g
Surface treatment	Anti-glare+EWV	
Back-light	CCFL, 1 tube	
Display mode	Normally white	
Gray scale inversion direction	6 o'clock [ ref to Note 13-1 ]	

**4.Mechanical Drawing of TFT-LCD Module**

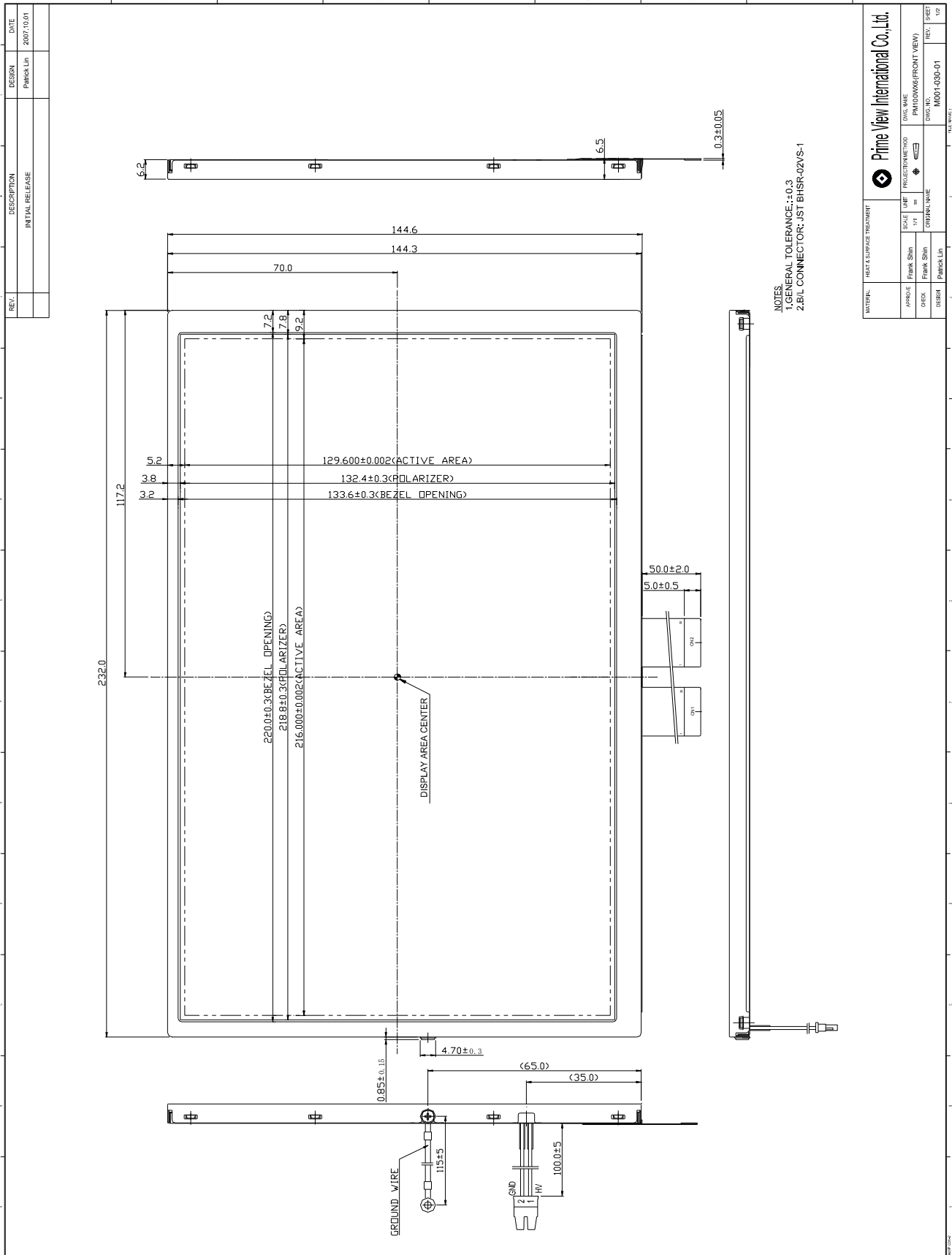

**PM100WX6**

REV.	DESCRIPTION	DESIGN	DATE
	INITIAL RELEASE	Patrick Lin	2007-10-01

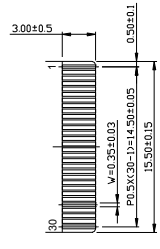
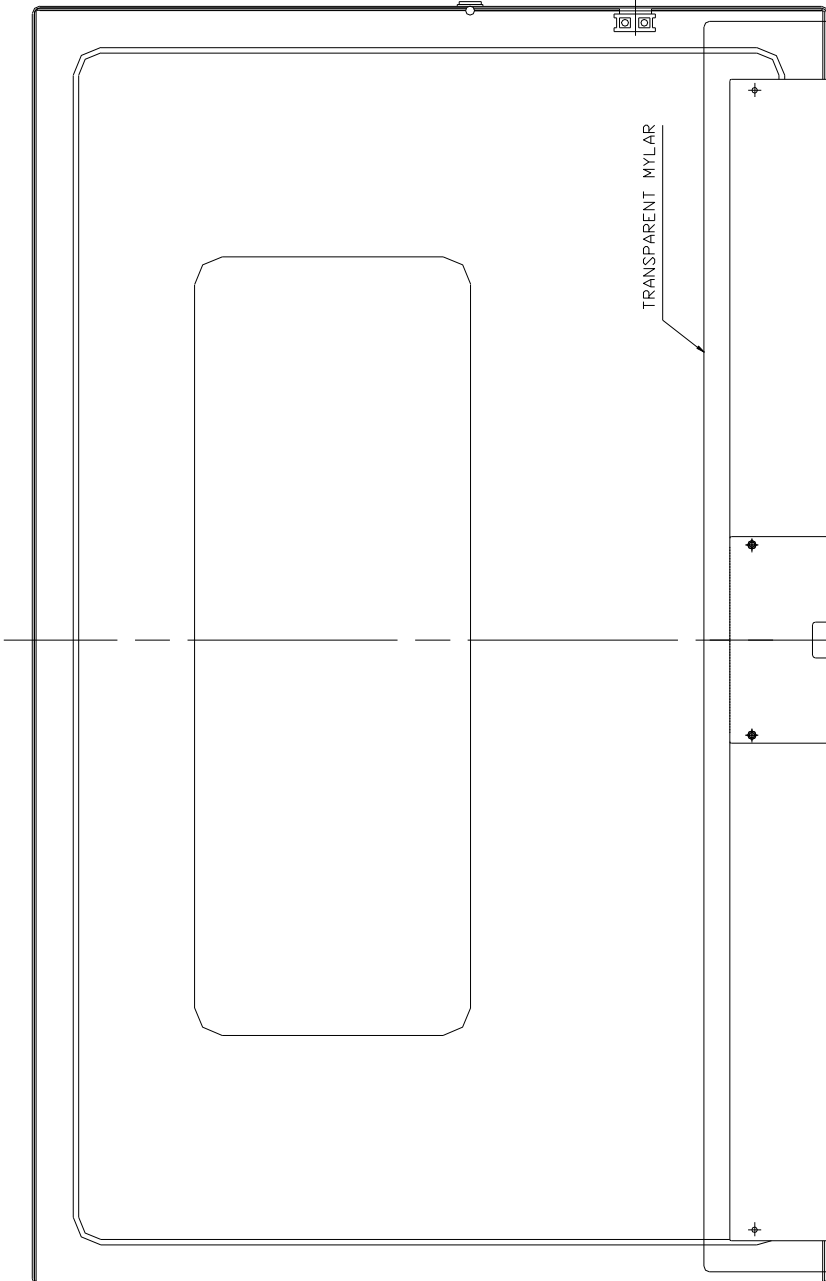

NOTES  
 1.GENERAL TOLERANCE:±0.3  
 2.B/L CONNECTOR: JST BHSR-02VS-1

MATERIAL		CHECK & SURFACE TREATMENT		Prime View International Co., Ltd.	
APPROVE	SCALE	UNIT	PROJECT/REV/NO	DATE/NAME	
Frank Shih	1:1	mm	PM100WX6(BACK VIEW)		
CHECK	ORIGINAL NAME			DWG. NO.	REV.
Patrick Lin				M001-030-01	2/2
DESIGN					

## 5. Input / Output Terminals

### 5-1) TFT-LCD Panel Driving

Connector type: IRISO, IMSA-9637S-30A-TC, PIN No 30 pins, pitch=0.5mm

#### CN 1

Pin No.	Symbol	I/O	Function	Remark
1	DIO1	I/O	Horizontal Start Pulse Signal Input or Output	Note 5-1
2	VSS1	I	Ground	
3	VDD1	I	Power Supply	
4	CLK	I	Horizontal Shift Clock	
5	VSS1	I	Ground	
6	R/L	I	Right / Left selection	Note 5-1
7	R0	I	Red Data (LSB)	
8	R1	I	Red Data	
9	R2	I	Red Data	
10	R3	I	Red Data	
11	R4	I	Red Data	
12	R5	I	Red Data (MSB)	
13	VSS1	I	Ground	
14	G0	I	Green Data (LSB)	
15	G1	I	Green Data	
16	G2	I	Green Data	
17	G3	I	Green Data	
18	G4	I	Green Data	
19	G5	I	Green Data (MSB)	
20	VSS1	I	Ground	
21	B0	I	Blue Data (LSB)	
22	B1	I	Blue Data	
23	B2	I	Blue Data	
24	B3	I	Blue Data	
25	B4	I	Blue Data	
26	B5	I	Blue Data (MSB)	
27	LD	I	Load output signal	Note 5-2
28	REV	I	Data invert control	Note 5-3
29	POL	I	Polarity selection	Note 5-4
30	DIO2	I/O	Horizontal Start Pulse Signal Input or Output	Note 5-1

## CN 2

Pin No.	Symbol	I/O	Function	Remark
1	VSS2	I	Ground	
2	V1	I	Gamma Voltage 1	Note 5-11
3	V2	I	Gamma Voltage 2	Note 5-11
4	V3	I	Gamma Voltage 3	Note 5-11
5	V4	I	Gamma Voltage 4	Note 5-11
6	V5	I	Gamma Voltage 5	Note 5-11
7	V6	I	Gamma Voltage 6	Note 5-11
8	V7	I	Gamma Voltage 7	Note 5-11
9	VSS2	I	Ground	
10	V8	I	Gamma Voltage 8	Note 5-11
11	V9	I	Gamma Voltage 9	Note 5-11
12	V10	I	Gamma Voltage 10	Note 5-11
13	V11	I	Gamma Voltage 11	Note 5-11
14	V12	I	Gamma Voltage 12	Note 5-11
15	V13	I	Gamma Voltage 13	Note 5-11
16	V14	I	Gamma Voltage 14	Note 5-11
17	VSS2	I	Ground	
18	VDD2	I	Voltage for analog circuit	Note 5-11
19	VCOM	I	Common Voltage	
20	XON	I	NC	Note5-10
21	OE	I	Output Enable	Note 5-5
22	U/D	I	Up / Down Selection	Note 5-6
23	CKV	I	Vertical Shift Clock	Note 5-7
24	STVU	I/O	Vertical Shift Pulse Signal Input or Output	Note 5-6
25	STVD	I/O	Vertical Shift Pulse Signal Input or Output	Note 5-6
26	VGG	I	Gate On Voltage	Note 5-8
27	GND	I	Ground	
28	VCC	I	Voltage for logic circuit	
29	GND	I	Ground	
30	VEE	I	Gate Off Voltage	Note 5-9

Note 5-1: Select left or right shift

R/L	DIO1	DIO2	Shift
1	Input	Hi-Z	Left to right
0	Hi-Z	Input	Right to left

Note 5-2: Latch the polarity of outputs and switch the new data to outputs  
At the rising edge (CLK), latch the "POL" signal to control the polarity of the outputs.

Note 5-3: Control whether the Data R0~G5 are inverted or not. (PVI suggests connecting to GND)  
When "REV=1", these data will be inverted.  
EX: "00"→"3F", "07"→"38", "15"→"2A"

Note 5-4: Polarity selector for dot-inversion control. Available at the rising edge of LD.  
When POL=1: Even outputs range from V1~V7, and Odd outputs range from V8~V14;  
When POL=0: Even outputs range from V8~V14, and Odd outputs range from V1~V7.

Note 5-5: When OE is connected to high “1”, the driver outputs are disabled (Gate output =  $V_{EE}$ ). Under this condition, the operation of registers will not be affected.

Note 5-6: Select up or down shift

U/D	STVU	STVD	Shift
1	Hi-Z	Input	Down to Up
0	Input	Hi-Z	Up to Down

Note 5-7: Gate driver shift clock

Note 5-8: Gate on voltage,  $V_{GG}=17V$ .

Note 5-9: Gate off voltage,  $V_{EE}=-8V$ .

Note 5-10: This pin is NC or must connect to VDD1

Note 5-11: Typical Application Circuit (When  $V_{DD2} = +9.6V$ )

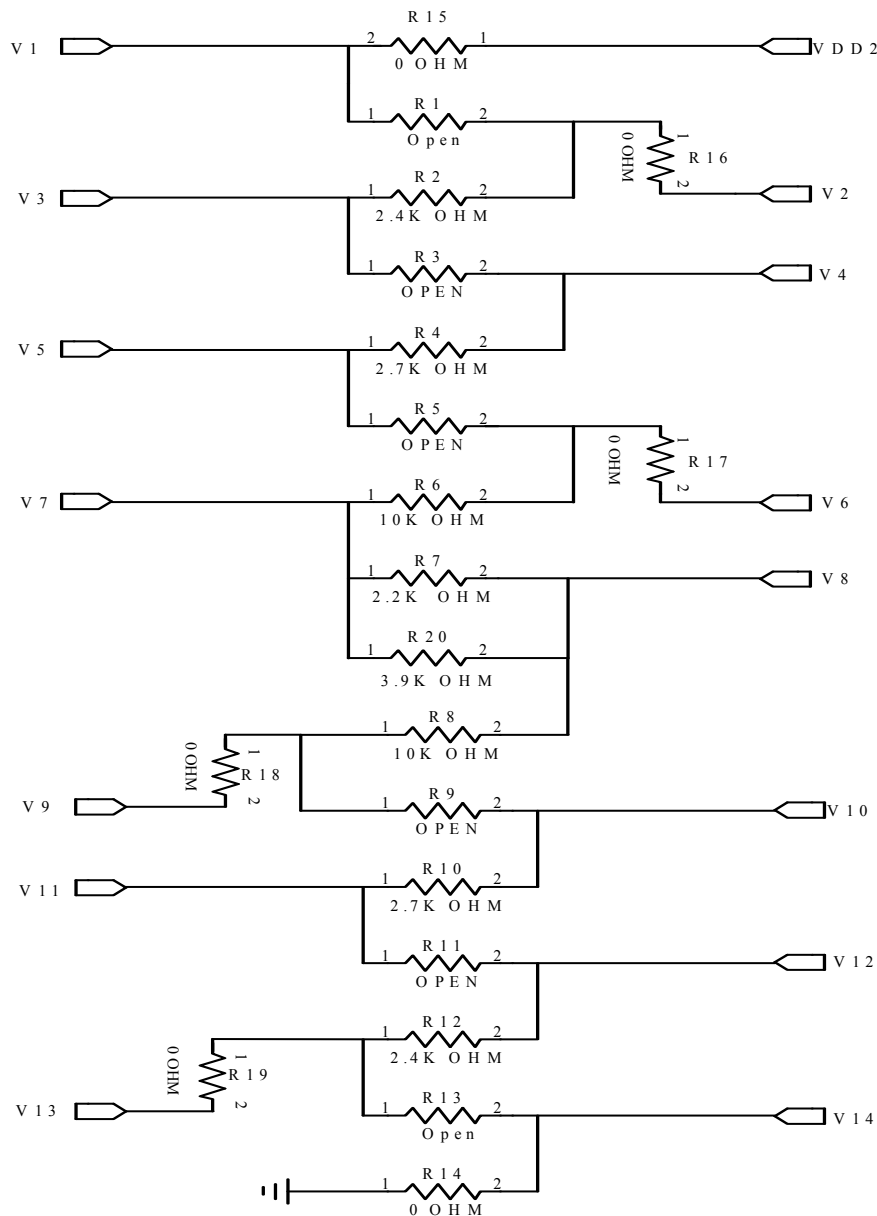

**6. Absolute Maximum Ratings:**
 $V_{SS1}=V_{SS2}=GND=0V, T_a=25^{\circ}C$ 

Parameters	Symbol	MIN.	MAX.	Unit	Remark
Supply Voltage for Source Driver	$V_{DD1}$	-0.3	5.0	V	
	$V_{DD2}$	-0.5	12.0	V	
Supply Voltage for Gate Driver	$V_{CC}$	-0.3	5.0	V	
	$V_{GG}$	-0.3	40.0	V	
	$V_{GG}-V_{EE}$	-	40	V	
	$V_{EE}$	-20	0.3	V	
Digital Input	$V_{IN}$	-0.5	$V_{CC}+0.5$	V	

**7. Electrical Characteristics**
**7-1) Recommended Operating Conditions:**
 $V_{SS1}=V_{SS2}=GND=0V, T_a=25^{\circ}C$ 

Item	Symbol	Min.	Typ.	Max.	Unit	Remark
Supply Voltage for Source Driver	$V_{DD1}$	3.0	3.3	3.6	V	
	$V_{DD2}$	9	9.6	10	V	
Supply Voltage for Gate Driver	$V_{GG}$	-	17	-	V	
	$V_{EE}$	-	-8	-	V	
	$V_{CC}$	3.0	3.3	3.6	V	
Digital Input Voltage	$V_{IH}$	$0.8V_{DD1}$	-	$V_{DD1}$	V	
	$V_{IL}$	0	-	$0.2V_{DD1}$	V	

**7-2) Recommended Driving Condition for Back Light**
 $T_a=25^{\circ}C$ 

Parameter	Symbol	Min.	Typ.	Max.	Unit	Remark
Lamp Voltage	$V_L$	720	800	880	V	$I_L=6mA$
Lamp Current	$I_L$	4	6	8	mA	Note 7-1
Lamp Frequency	$P_L$	30	45	80	KHz	Note 7-2
Starting Voltage (25°C) (Reference Value)	$V_s$	-	-	1380	Vrms	Note 7-3
Starting Voltage (0°C) (Reference Value)	$V_s$	-	-	1510	Vrms	Note 7-3
Starting Voltage (-20°C) (Reference Value)	$V_s$	-	-	1650	Vrms	Note 7-3

Note 7-1: In order to have proper operation of the B/L, no matter what kind of inverters, the output lamp current must be between Min. and Max. values to avoid the abnormal display image caused by B/L.

Note 7-2: The waveform of lamp driving voltage should be as close to a perfect sine wave as possible.

Note 7-3: The "Max of starting voltage" means the minimum voltage of inverter to turn on the CCFL. and it should be applied to the lamp for more than 1 second to start up. Otherwise the lamp may not be turned on.

**7-3) Power Consumption**

Parameter	Symbol	Min.	Typ.	Max.	Unit	Remark
Supply Current for Gate Driver (Hi level)	$I_{GG}$	$V_{GH}=+17V$	0.16	0.48	mA	
Supply Current for Gate Driver (Low level)	$I_{EE}$	$V_{EE}=-8V$	2.03	6.09	mA	
Supply Current for Source Driver (Digital)	$I_{DD1}$	$V_{DD1}=+3.3V$	2.19	4.38	mA	
Supply Current for Source Driver (Analog)	$I_{DD2}$	$V_{DD2}=+9.6V$	27.47	54.94	mA	
Supply Current for Gate Driver (Digital)	$I_{CC}$	$V_{CC}=+3.3V$	0.1	0.3	mA	
LCD Panel Power Consumption			290.2	-	mW	Note 7-4
Back Light Lamp Power Consumption			5.09	-	W	Note 7-5

Note 7-4: The power consumption for back light is not included.

Note 7-5: Back light lamp power consumption is calculated by  $I_L \times V_L$ .

**8. Pixel Arrangement**

The LCD module pixel arrangement is stripe configuration.

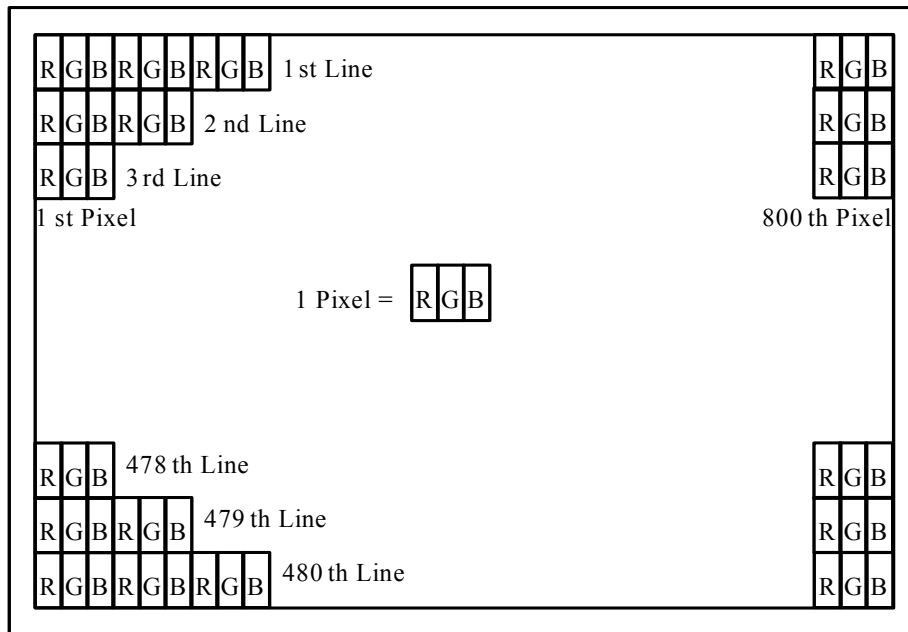

9. Display Color and Gray Scale Reference

Color		Input Color Data																	
		Red						Green						Blue					
		R5	R4	R3	R2	R1	R0	G5	G4	G3	G2	G1	G0	B5	B4	B3	B2	B1	B0
Basic Colors	Black	0	0	0	0	0	0	0	0	0	0	0	0	0	0	0	0	0	0
	Red (63)	1	1	1	1	1	1	0	0	0	0	0	0	0	0	0	0	0	0
	Green (63)	0	0	0	0	0	0	1	1	1	1	1	1	0	0	0	0	0	0
	Blue (63)	0	0	0	0	0	0	0	0	0	0	0	0	1	1	1	1	1	1
	Cyan	0	0	0	0	0	0	1	1	1	1	1	1	1	1	1	1	1	1
	Magenta	1	1	1	1	1	1	0	0	0	0	0	0	1	1	1	1	1	1
	Yellow	1	1	1	1	1	1	1	1	1	1	1	1	0	0	0	0	0	0
	White	1	1	1	1	1	1	1	1	1	1	1	1	1	1	1	1	1	1
Red	Red (00)	0	0	0	0	0	0	0	0	0	0	0	0	0	0	0	0	0	0
	Red (01)	0	0	0	0	0	1	0	0	0	0	0	0	0	0	0	0	0	0
	Red (02)	0	0	0	0	1	0	0	0	0	0	0	0	0	0	0	0	0	0
	Darker																		
	↓	↓	↓	↓	↓	↓	↓	↓	↓	↓	↓	↓	↓	↓	↓	↓	↓	↓	↓
	Brighter																		
	Red (61)	1	1	1	1	0	1	0	0	0	0	0	0	0	0	0	0	0	0
	Red (62)	1	1	1	1	1	0	0	0	0	0	0	0	0	0	0	0	0	0
	Red (63)	1	1	1	1	1	1	0	0	0	0	0	0	0	0	0	0	0	0
Green	Green (00)	0	0	0	0	0	0	0	0	0	0	0	0	0	0	0	0	0	0
	Green (01)	0	0	0	0	0	0	0	0	0	0	0	1	0	0	0	0	0	0
	Green (02)	0	0	0	0	0	0	0	0	0	0	1	0	0	0	0	0	0	0
	Darker																		
	↓	↓	↓	↓	↓	↓	↓	↓	↓	↓	↓	↓	↓	↓	↓	↓	↓	↓	↓
	Brighter																		
	Green (61)	0	0	0	0	0	0	1	1	1	1	0	1	0	0	0	0	0	0
	Green (62)	0	0	0	0	0	0	1	1	1	1	1	0	0	0	0	0	0	0
	Green (63)	0	0	0	0	0	0	1	1	1	1	1	1	0	0	0	0	0	0
Blue	Blue (00)	0	0	0	0	0	0	0	0	0	0	0	0	0	0	0	0	0	0
	Blue (01)	0	0	0	0	0	0	0	0	0	0	0	0	0	0	0	0	0	1
	Blue (02)	0	0	0	0	0	0	0	0	0	0	0	0	0	0	0	0	1	0
	Darker																		
	↓	↓	↓	↓	↓	↓	↓	↓	↓	↓	↓	↓	↓	↓	↓	↓	↓	↓	↓
	Brighter																		
	Blue (61)	0	0	0	0	0	0	0	0	0	0	0	0	1	1	1	1	0	1
	Blue (62)	0	0	0	0	0	0	0	0	0	0	0	0	1	1	1	1	1	0
	Blue (63)	0	0	0	0	0	0	0	0	0	0	0	0	1	1	1	1	1	1

**10. Block Diagram**

**10-1) TFT-module Block Diagram**

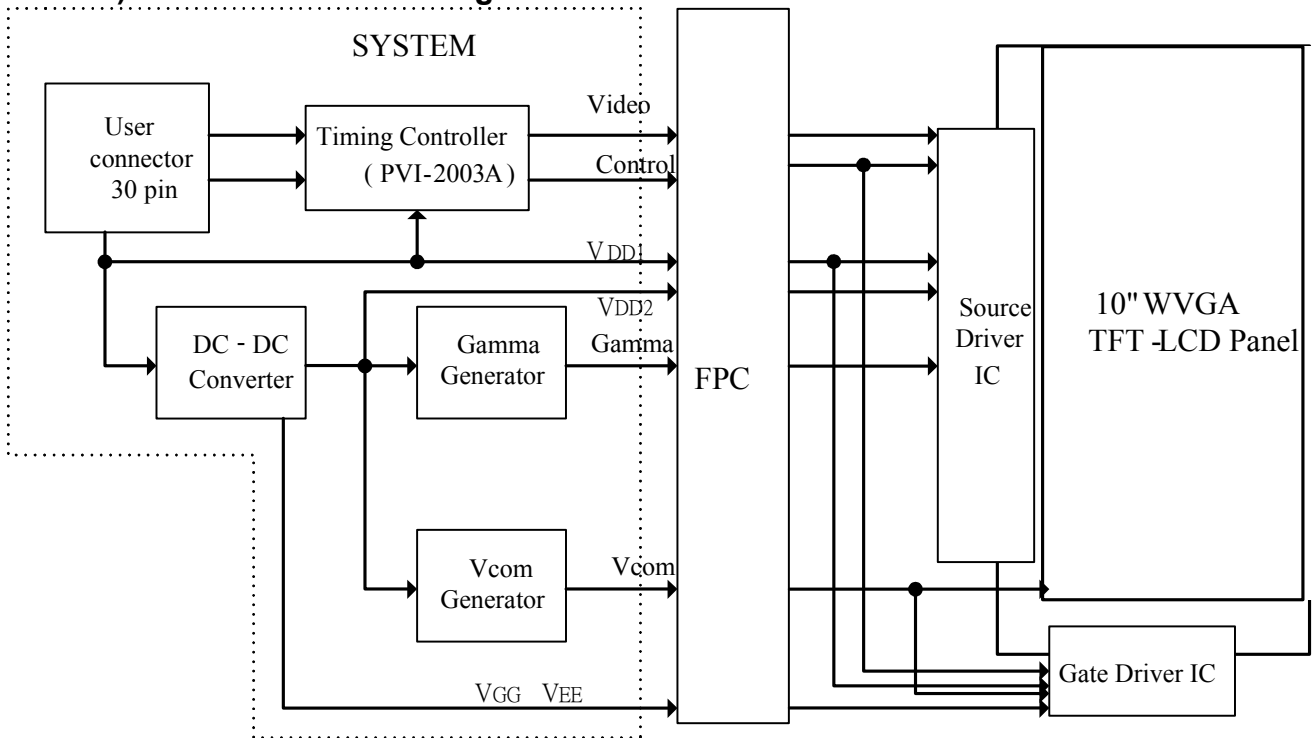

If you use PM100WX6 , you can apply PVI-2003A( Timing controller) which will generate timing signals to support PM100WX6

## 11. Interface Timing

### 11.1) Timing Parameters

AC Electrical Characteristics ( $V_{CC}=V_{DD1}=3.3V$ ,  $V_{DD2}=9.6V$ ,  $GND=V_{SS1}=V_{SS2}=0V$ ,  $T_a=25^{\circ}C$ )

Parameter	Symbol	Min.	Typ.	Max.	Unit
CLK Frequency	Fclk	-	32	40	MHz
CLK Pulse Width	Tcw	25	-	-	ns
Data Set-up Time	Tsu	4	-	-	ns
Data Hold Time	Thd	2	-	-	ns
Propagation Delay of DIO2/1	Tphl	6	10	15	ns
Time That The Last Data to LD	Tld	1	-	-	Tcw
Pulse width of LD	Twld	2	-	-	Tcw
Time That LD to DIO1/2	Tlds	5	-	-	Tcw
POL Set-up Time	Tpsu	6	-	-	ns
POL Hold Time	Tphd	6	-	-	ns
OE Pulse Width	T <sub>OE</sub> V	1	-	-	μs
CKV Pulse Width	T <sub>CKV</sub>	500	-	-	ns
STV Set-up Time	T <sub>SUV</sub>	400	-	-	ns
STV Hold Time	T <sub>HDV</sub>	400	-	-	ns
Horizontal Display Period	T <sub>HDP</sub>	-	800	-	Tcw
Horizontal Period Timing Range	T <sub>HP</sub>	-	1056	-	Tcw
Horizontal Lines Per Field	T <sub>V</sub>	484	508	620	T <sub>HP</sub>
Vertical Display Timing Range	T <sub>DV</sub>	-	480	-	T <sub>HP</sub>

**11.2) Timing Diagram**

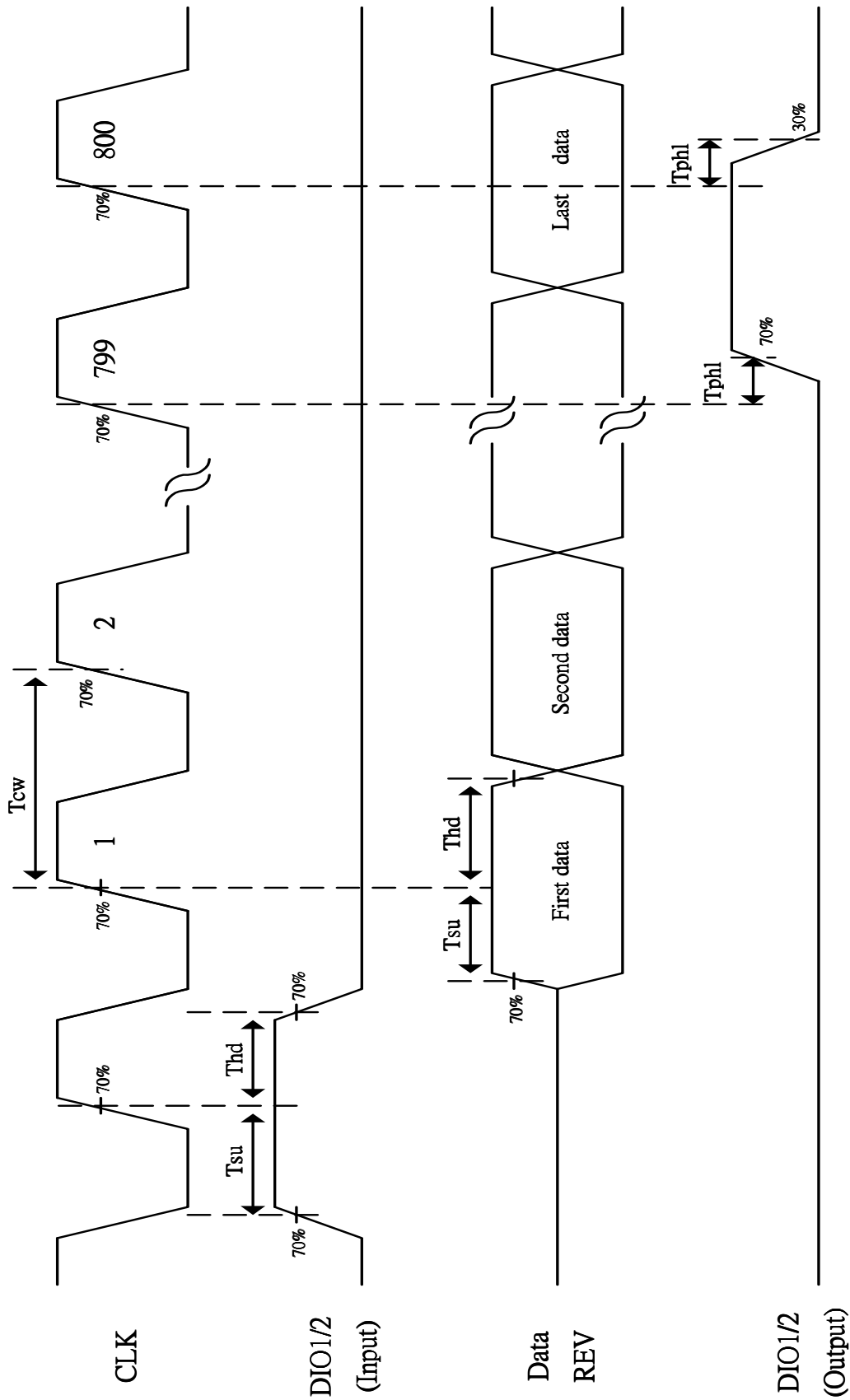

Fig. 11-1 Horizontal Timing(1)

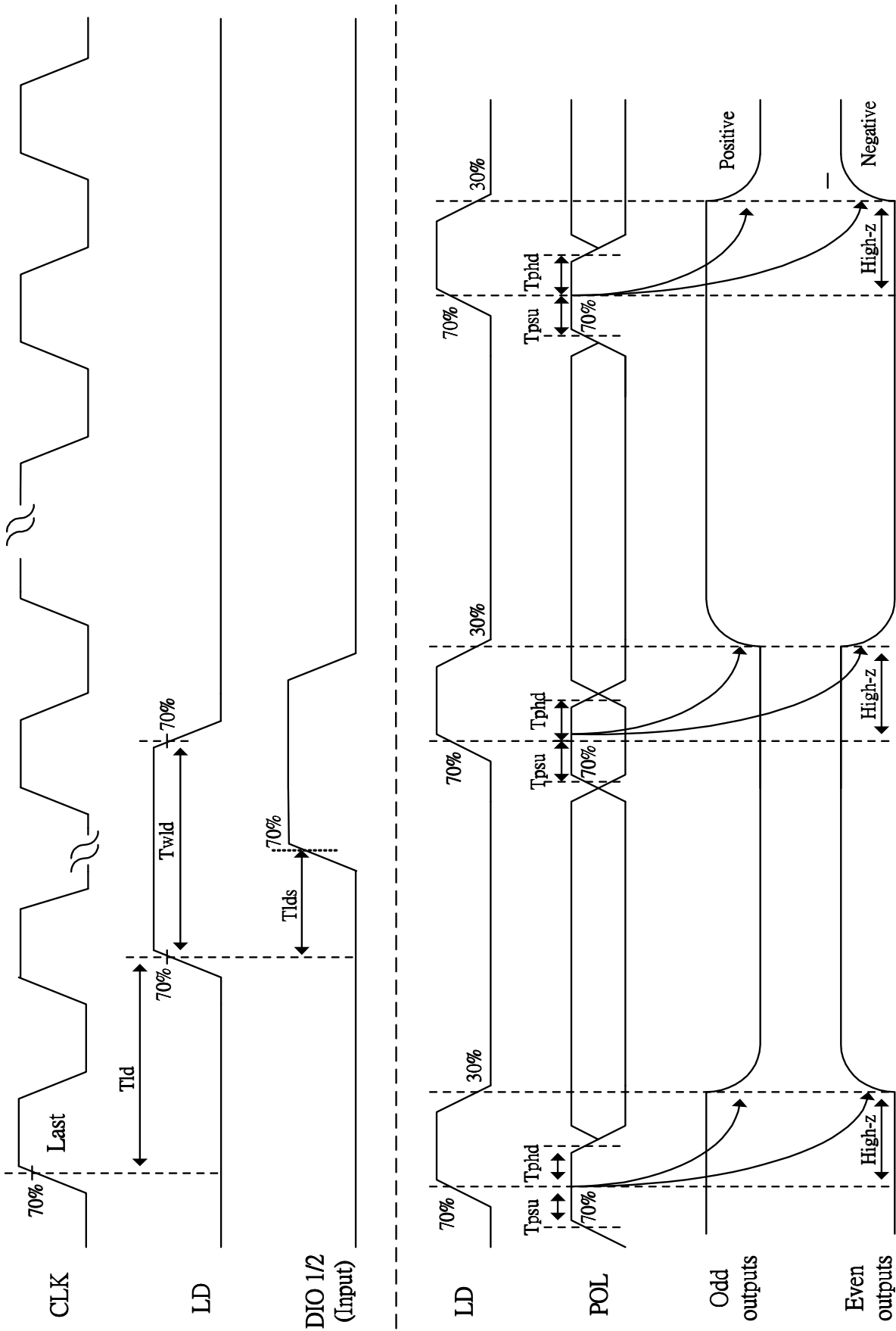

Fig. 11-2 Horizontal timing(2)

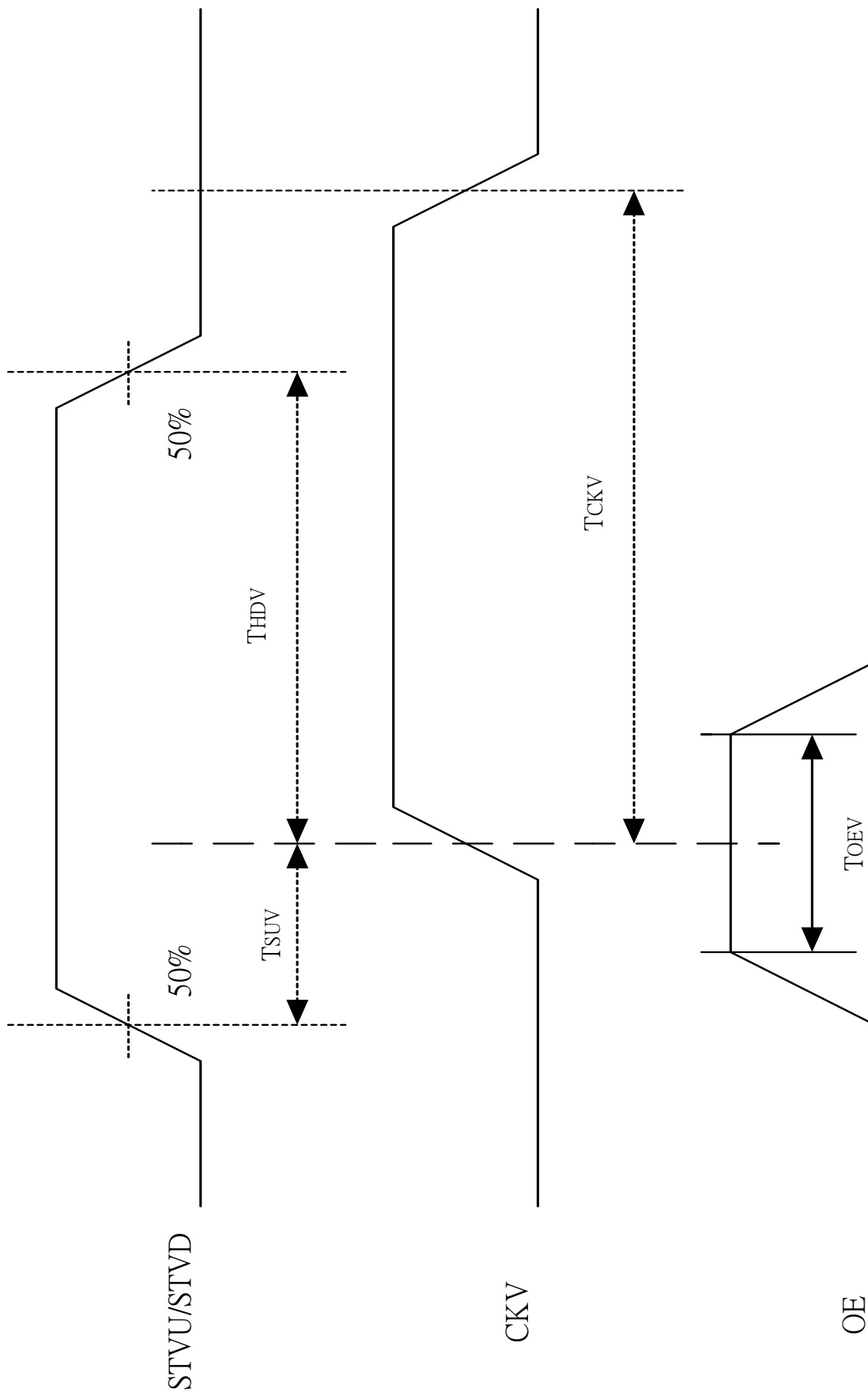

Fig. 11-3 Vertical shift clock timing

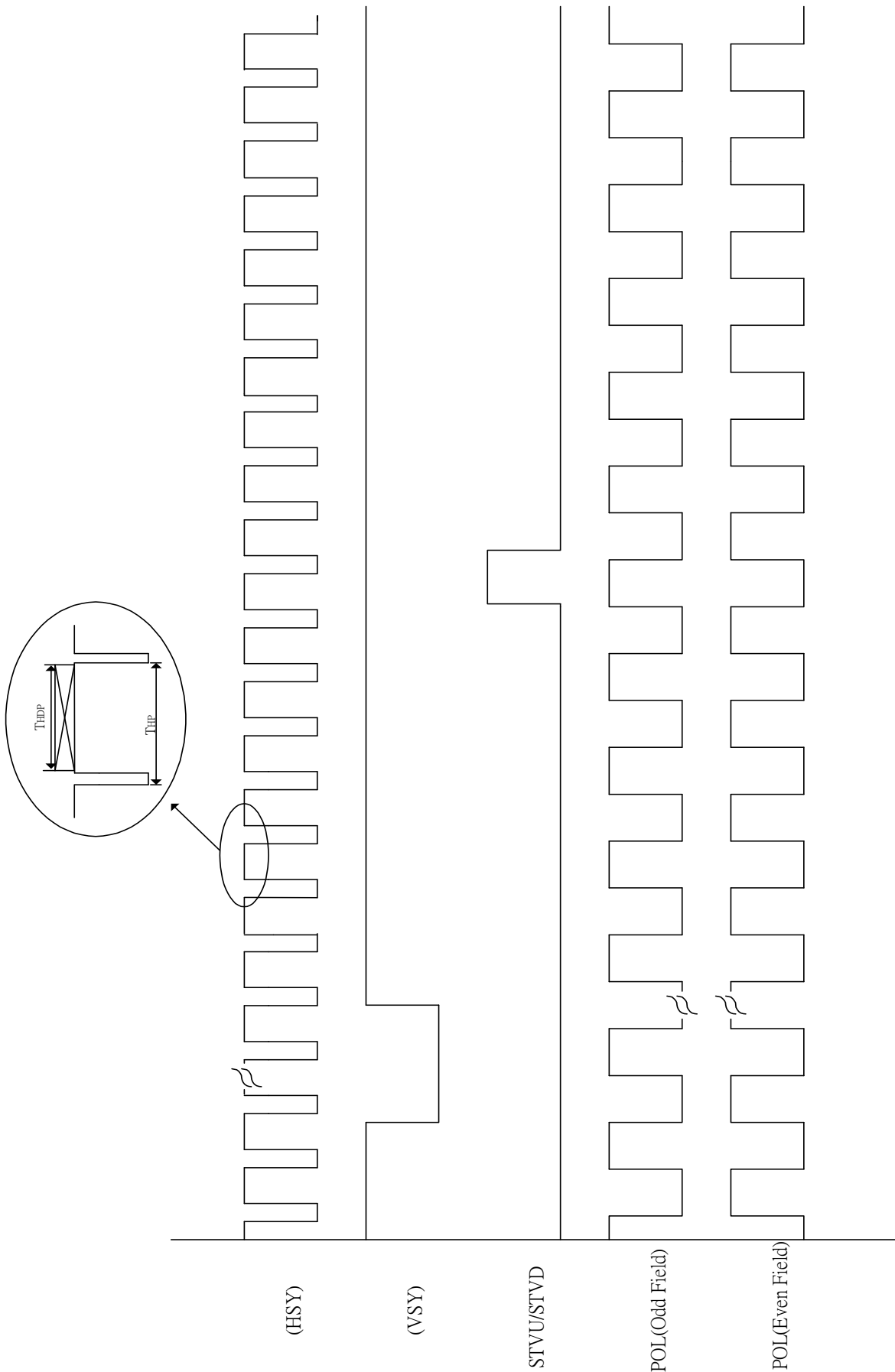
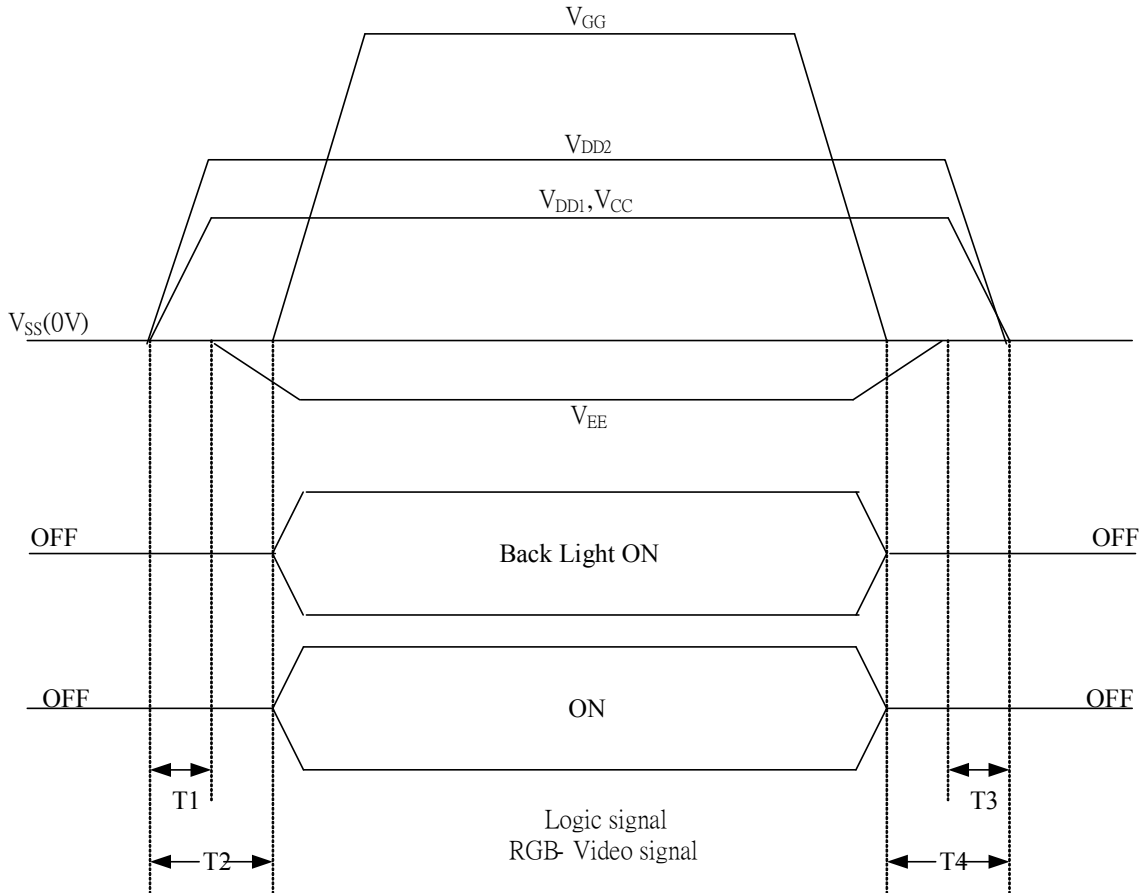

Fig. 11-4 Vertical timing

**12. Power On Sequence**



1.  $10\text{ms} \leq T1 < T2$
2.  $0\text{ms} < T3 \leq T4 \leq 10\text{ms}$

**13. Optical Characteristics**

**13-1) Specification:**

Ta=25°C

Parameter	Symbol	Condition	MIN.	TYP.	MAX.	Unit	Remarks
Viewing Angle	Horizontal	CR > 10	65	70	-	deg	Note 13-1
	Vertical		55	60	-	deg	
			45	50	-	deg	
Contrast Ratio	CR	At optimized viewing angle	200	500	-	-	Note 13-2
Brightness		$\theta = 0^\circ / \varphi = 0$	350	400	-	cd/m <sup>2</sup>	Note 13-4
Luminance Uniformity	U		70	80	-	%	Note 13-5
White Chromaticity	x		0.28	0.31	0.34	-	
	y		0.31	0.34	0.37	-	
Response time	Rise	$\theta = 0^\circ$	-	15	30	ms	Note 13-3
	Fall		-	25	50	ms	
Cross Talk	-	$\theta = 0^\circ$	-	-	3.5	%	Note 13-6
Lamp Life Time	-	+25°C	-	30000	---	hrs	

Note 13-1: The definitions of viewing angles are as follow

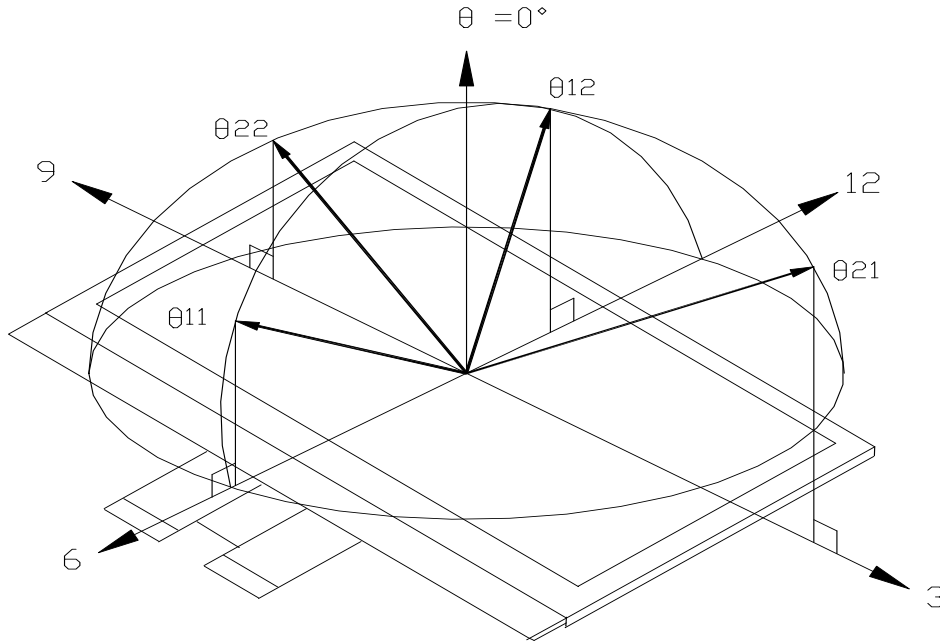

Note 13-2: The definition of contrast ratio  $CR = \frac{\text{Luminance at gray level 63}}{\text{Luminance at gray level 0}}$

Note 13-3: Definition of Response Time  $T_r$  and  $T_f$ :

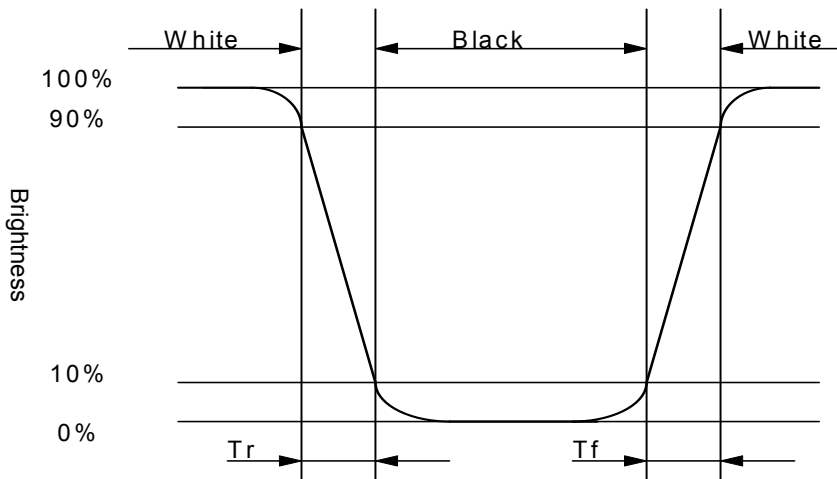

Note 13-4: Topcon BM-5A or BM-7 fast luminance meter 1° field of view is used in the testing (after 30 minutes' operation). The typical luminance value is measured at lamp current 6.0 mA.

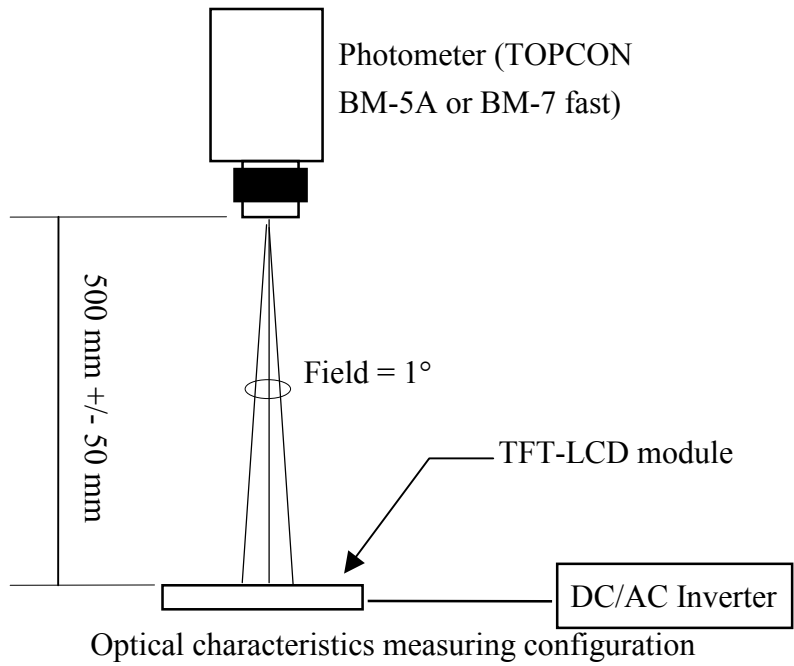

Note 13-5: The uniformity of LCD is defined as

$$U = \frac{\text{The Minimum Brightness of the 9 testing Points}}{\text{The Maximum Brightness of the 9 testing Points}}$$

Luminance meter: BM-5A or BM-7 fast (TOPCON)

Measurement distance: 500 mm +/- 50 mm

Ambient illumination: < 1 Lux

Measuring direction: Perpendicular to the surface of module

The test pattern is white (Gray Level 63).

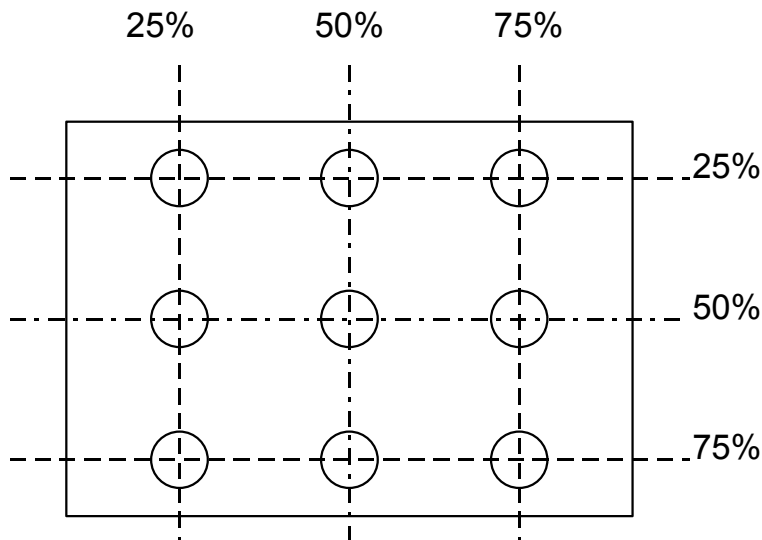

Note 13-6: Cross Talk (CTK) =  $\frac{|YA-YB|}{YA} \times 100\%$

YA: Brightness of Pattern A

YB: Brightness of Pattern B

Luminance meter: BM-5A or BM-7 fast (TOPCON)

Measurement distance: 500 mm +/- 50 mm

Ambient illumination: < 1 Lux

Measuring direction: Perpendicular to the surface of module

Pattern A  
(Gray Level 31)

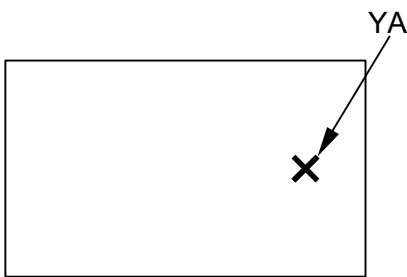

Pattern B  
(Gray Level 31, except the black box in the center )

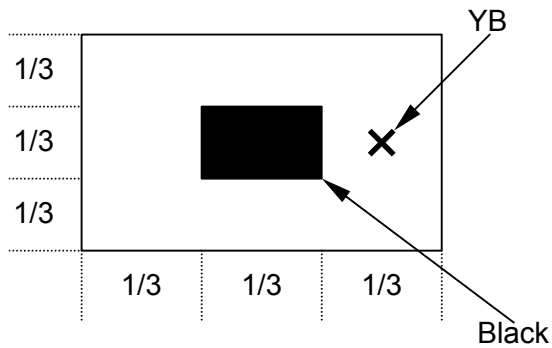

**X**: Measuring Point (A and B are at the same point.)

Black (Gray Level 0)

**14. Handling Cautions****14-1) Mounting of module**

- a) Please power off the module when you connect the input/output connector.
- b) Please connect the ground pattern of the inverter circuit surely. If the connection is not perfect, some following problems may happen possibly.
  - 1. The noise from the backlight unit will increase.
  - 2. The output from inverter circuit will be unstable.
  - 3. In some cases a part of module will heat.
- c) Polarizer which is made of soft material and susceptible to flaw must be handled carefully.
- d) Protective film (Laminator) is applied on surface to protect it against scratches and dirt. It is recommended to peel off the laminator before use and taking care of static electricity.

**14-2) Precautions in mounting**

- a) Wipe off water drops or finger grease immediately. Long contact with water may cause discoloration or spots.
- b) TFT-LCD module uses glass which breaks or cracks easily if dropped or bumped on hard surface. Please handle with care.
- c) Since CMOS LSI is used in the module. So take care of static electricity and earth yourself when handling.

**14-3) Adjusting module**

- a) Adjusting volumes on the rear face of the module have been set optimally before shipment.
- b) Therefore, do not change any adjusted values. If adjusted values are changed, the specifications described may not be satisfied.

**14-4) Others**

- a) Do not expose the module to direct sunlight or intensive ultraviolet rays for many hours.
- b) Store the module at a room temperature place.
- c) The voltage of beginning electric discharge may over the normal voltage because of leakage current from approach conductor by to draw lump read lead line around.
- d) If LCD panel breaks, it is possibly that the liquid crystal escapes from the panel. Avoid putting it into eyes or mouth. When liquid crystal sticks on hands, clothes or feet. Wash it out immediately with soap.
- e) Observe all other precautionary requirements in handling general electronic components.
- f) Please adjust the voltage of common electrode as material of attachment by 1 module.

**15. Reliability Test**

No	Test Item	Test Condition	Remark
1	High Temperature Storage Test	Ta = +80°C, 240 hrs	
2	Low Temperature Storage Test	Ta = -30°C, 240 hrs	
3	High Temperature Operation Test	Ta = +80°C, 240 hrs	
4	Low Temperature Operation Test	Ta = -20°C, 240 hrs	
5	High Temperature & High Humidity Operation Test	Ta = +60°C, 90%RH, 240 hrs (No Condensation)	
6	Thermal Cycling Test (non-operating)	0°C → +60°C, 50 Cycles 1Hr 1Hr	
7	Vibration Test (non-operating)	Frequency : 10 ~ 57 Hz, Amplitude : 0.5 mm 58~500Hz, 1G Sweep time: 11 min Test Period: 3 hrs (1 hr for each direction of X, Y, Z)	
8	Shock Test (non-operating)	80G, 6ms, X,Y, Z 1 times for each direction	
9	Electrostatic Discharge Test (non-operating)	200pF, 0Ω ±200V 1 time / each terminal	

Ta: ambient temperature

[Criteria]

1. In the standard conditions, there is not display function NG issue occurred. (including :line defect ,no image) All the cosmetic specification is judged before the reliability stress

**16. Packing Diagram**

