

mass integrated

global part distribution • product lifecycle partner
excess inventory management • value-ad service provider



Data sheet provided by Mass Integrated

massintegrated.com • displayalliance.com

Please call +1.978.465.6190
Email: sales@massintegrated.com



ISO 9001: 2008

Mass Integrated complies with all DMCA takedown notices. Please send a formal DMCA Takedown Notice to Mass Integrated Systems, Inc. • 18 Henry Graf Jr. Road, Unit 1 • Newburyport, MA 01950.

INNOLUX DISPLAY CORPORATION

LCD MODULE

SPECIFICATION

Customer: _____
Model Name: PT035TN23 V.1
SPEC NO.: P035-23-TT-13
Date: 2009/06/01
Version: 03

- Preliminary Specification
 Final Specification

Remark
<input checked="" type="checkbox"/> Touch Screen Panel (3-in-1FPC)

For Customer's Acceptance

Approved by	Comment

Approved by	Reviewed by	Prepared by
Joe Lin 2009/06/11	Jack Huang James Yu 2009/06/11	David Lee 2009/06/08

Record of Revision

Version	Revise Date	Page	Content
Pre-spec. 01	2008/06/21		Initial Release
02	2008/07/08	3	Modify Pin 59 and Pin 60 Assignment
		5	Modify Value of Operate Temperature and Storage Temperature
		5	Modify Note 3
		21	Modify Test Condition of Operate at High Temperature and Humidity
Final-spec.01	2008/08/07	1	Modify General Specifications(Add Value of Weight)
		6	Modify Values of Current for Driver
		7	Modify Power Sequence and Add Note
		12	Add Note (3-Wire Writer Format)
		17	Modify Response time from $T_{ON:10}/T_{OFF:15}$ to $T_{ON:9}/T_{OFF:16}$
		23	Modify Mechanical Drawing
		24	Modify Packaging Quantity
		25	Add Packaging Drawing
02	2009/01/05	8	Modify Min. Value of DCLK clock time
		8	Modify Value of Hsync period time
		9	Add Max. Value of DCLK frequency
		9	Modify Value of DCLK cycle time
		13	Add Reference circuit
		14	Add Value of Linearity
		25	Modify Weight of Tray
		26	Modify Packaging Drawing(Add empty tray)

Record of Revision

Version	Revise Date	Page	Content
03	2009/06/01	1	Modify general specification: weight from 42g to 43g
		24	Add note: FPC connector type
		25	Modify packaging material table, quantity and drawing

Contents

1. General Specifications	1
2. Pin Assignment	2
2.1 TFT LCD Panel Driving Section	2
2.2. Touch Screen Panel Section	4
3. Operation Specifications	5
3.1. Absolute Maximum Ratings	5
3.2. Typical Operation Conditions	6
3.3. Backlight Driving Condition	6
3.4. Power Sequence	7
3.5. Timing Characteristics	8
3.5.1. AC Electrical Characteristics	8
3.5.2. Timing Diagram	10
3.5.3. Reference circuit	13
4. Touch Screen Panel Specifications	14
4.1. Electrical Characteristics	14
4.2. Mechanical & Reliability Characteristics	15
4.3. Linearity Definition	16
4.4. Housing design guide	17
5. Optical Specifications	18
6. Reliability Test Items	22
7. Handling Precautions	23
7.1. Safety	23
7.2. Handling	23
7.3. Static Electricity	23
7.4. Storage	23
7.5. Cleaning	23
8. Mechanical Drawing	24
9. Package Drawing	25
9.1. Packaging Material Table	25
9.2. Packaging Quantity	25
9.3. Packaging Drawing	26

1. General Specifications

No.	Item	Specification	Remark
1	LCD size	3.5" inch	
2	Driver element	a-Si TFT active matrix	
3	Resolution	320 × 3(RGB) × 240	
4	Display mode	Normally White, Transmissive	
5	Dot pitch	0.073(W) × 0.219(H) mm	
6	Active area	70.08(W) × 52.56(H) mm	
7	Module size	76.9(W) × 64.4(H) × 4.23(D) mm	Note 1
8	Surface treatment	Anti-glare	
9	Color arrangement	RGB-stripe	
10	Interface	Digital	
11	Backlight power consumption	0.396W (typ.)	
12	Panel power consumption	0.040W (typ.)	
13	Weight	43g (typ.)	

Note 1: Refer to Mechanical Drawing.

2. Pin Assignment

2.1 TFT LCD Panel Driving Section

FPC connector is used for the module electronics interface. The recommended model is “FH28-60S-0.5SH(51)” manufactured by Hirose.

Pin No.	Symbol	I/O	Function	Remark
1	V _{LED-}	P	Power for LED backlight cathode	
2	V _{LED+}	P	Power for LED backlight anode	
3	GND	P	Power Ground	
4	X1	I/O	Touch Panel Right Electrode	
5	Y2	I/O	Touch Panel Bottom Electrode	
6	X2	I/O	Touch Panel Left Electrode	
7	Y1	I/O	Touch Panel Top Electrode	
8	C4M	I	Boost capacitor	
9	C4P	I		
10	VGH	I	Stabilizing capacitor	
11	C3M	I	Boost capacitor	
12	C3P	I		
13	C2P	I	Boost capacitor	
14	C2M	I		
15	C1AP	I	Boost capacitor	
16	C1AM	I		
17	C1M	I	Boost capacitor	
18	C1P	I		
19	GND	P	Power Ground	
20	V _{DD}	P	Power voltage	
21	VGL	I	Stabilizing capacitor	
22	Vint2	I	Stabilizing capacitor	
23	V _{DD}	P	Power voltage	
24	VCOMOUT	I	Coupled capacitor	
25	VCOMDC	I		
26	GND	P	Power Ground	

版權屬於群創所有，禁止任何未經授權的使用

27	Vint1	I	Stabilizing capacitor	
28	VCOMAC	I	Stabilizing capacitor	
29	VDDA	C	Stabilizing capacitor	
30	RESET	I	Global Reset Pin	
31	SPDA	I/O	SPI interface input pin	
32	SPCK	I	SPI clock signal	
33	SPENB	I	SPI chip select signal	
34	DE	I	Data enable pin	
35	Hsync	I	Horizontal Synchronizing input signal	
36	Vsync	I	Vertical Synchronizing input signal	
37	GND	P	Power Ground	
38	DCLK	I	DCLK	
39	GND	P	Power Ground	
40	B5	I	Blue data	
41	B4	I	Blue data	
42	B3	I	Blue data	
43	B2	I	Blue data	
44	B1	I	Blue data	
45	B0	I	Blue data	
46	G5	I	Green data	
47	G4	I	Green data	
48	G3	I	Green data	
49	G2	I	Green data	
50	G1	I	Green data	
51	G0	I	Green data	
52	R5	I	Red data	
53	R4	I	Red data	
54	R3	I	Red data	
55	R2	I	Red data	
56	R1	I	Red data	
57	R0	I	Red data	
58	NC	-	No Connection	
59	GND	P	Power Ground	
60	GND	P	Power Ground	

2.2. Touch Screen Panel Section

Pin No.	Symbol	I/O	Function	Remark
1	X1	Right	Touch Panel Right Electrode	
2	Y2	Bottom	Touch Panel Bottom Electrode	
3	X2	Left	Touch Panel Left Electrode	
4	Y1	Top	Touch Panel Top Electrode	

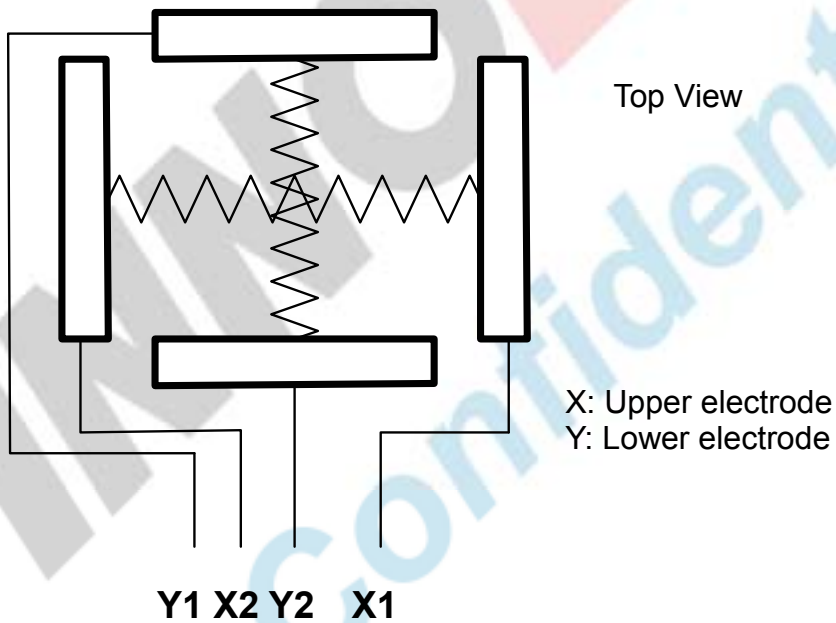

3. Operation Specifications

3.1. Absolute Maximum Ratings

(GND =0V, Note 1)

Item	Symbol	Values		Unit	Remark
		Min.	Max.		
Power voltage	V _{DD}	-0.3	5	V	
Operation temperature	T _{OP}	-20	70	°C	Note 3, 4
Storage temperature	T _{ST}	-30	80	°C	Note 3, 4
LED Reverse Voltage	V _r	-	1.2	V	Each LED Note 2
LED Forward Current	I _f	-	25	mA	Each LED

Note 1: Device is subject to be damaged permanently if stresses beyond those absolute maximum ratings listed above.

Note 2: V_r conditions: Zener Diode 20mA.

Note 3: 90% RH Max. (Max wet temp. is 60°C)

Maximum wet-bulb temperature is at 60°C or less. And No condensation (no drops of dew)

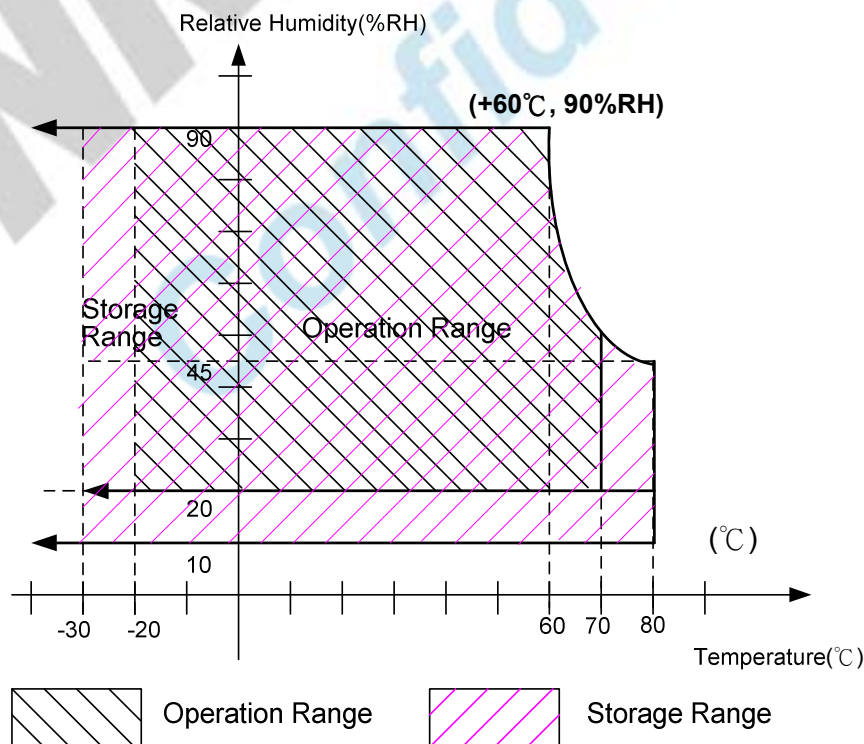

Note 4: In case of temperature below 0°C, the response time of liquid crystal (LC) becomes slower and the color of panel darker than normal one.

版權屬於研創所有，禁止任何未經授權的使用

The copyright belongs to InnoLux. Any unauthorized use is prohibited.

3.2. Typical Operation Conditions

(GND =0V)

Item	Symbol	Values			Unit	Remark
		Min.	Typ.	Max.		
Power voltage	V_{DD}	3.2	3.3	3.4	V	
Current for Driver	$I_{V_{DD}}$	-	12	18	mA	$V_{DD} = 3.3V$
Input logic high voltage	V_{IH}	$0.8V_{DD}$	-	V_{DD}	V	
Input logic low voltage	V_{IL}	0	-	$0.2V_{DD}$	V	

3.3. Backlight Driving Condition

Item	Symbol	Values			Unit	Remark
		Min.	Typ.	Max.		
Voltage for LED Backlight	V_L	18.6	19.8	21	V	
Current for LED Backlight	I_L	18	20	22	mA	
LED life time	-	20,000	-	-	Hr	Note 1

Note 1: The “LED life time” is defined as the module brightness decrease to 50% original brightness that the ambient temperature is 25°C and $I_L = 20mA$. The LED lifetime could be decreased if operating I_L is larger than 20 mA.

3.4. Power Sequence

3.4.1. Power on:

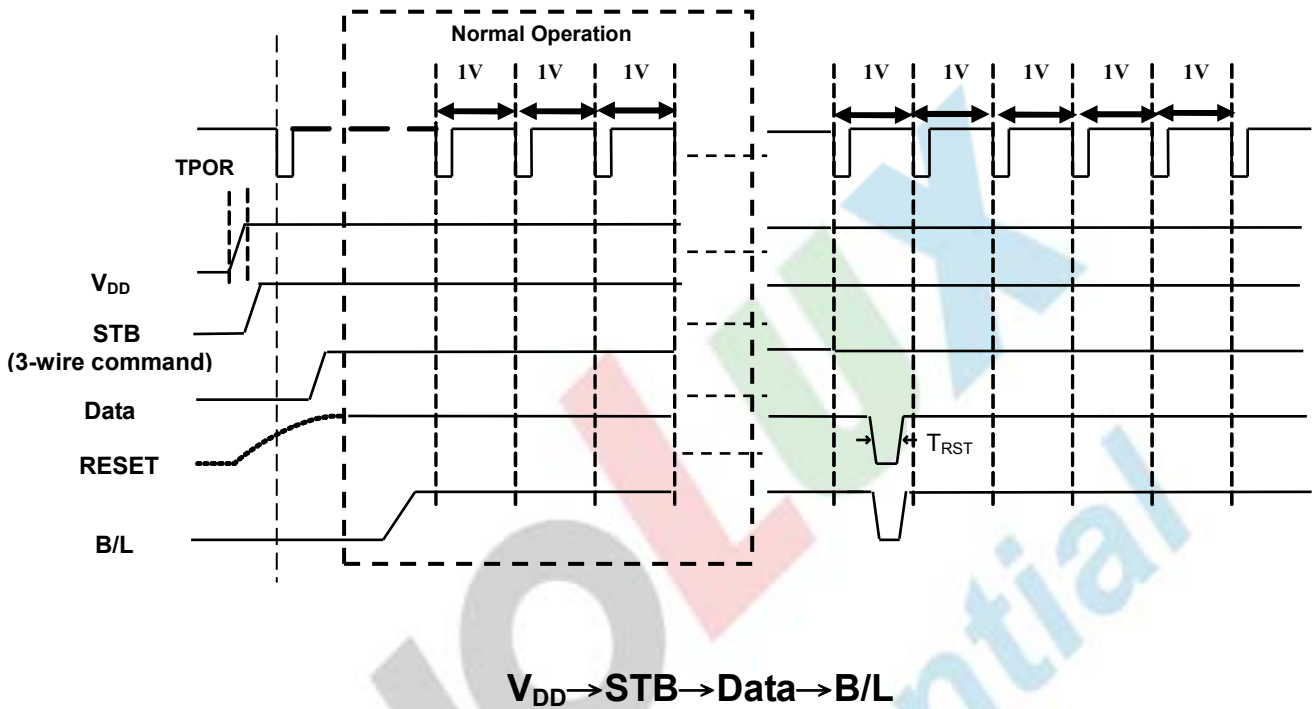

Note: External Reset(RESET)

To prevent from abnormal reset condition, a glitch filter for RESET is embedded in this chip. The external reset signal should keep active for large then reset time(T_{RST}).

3.4.2. Power off:

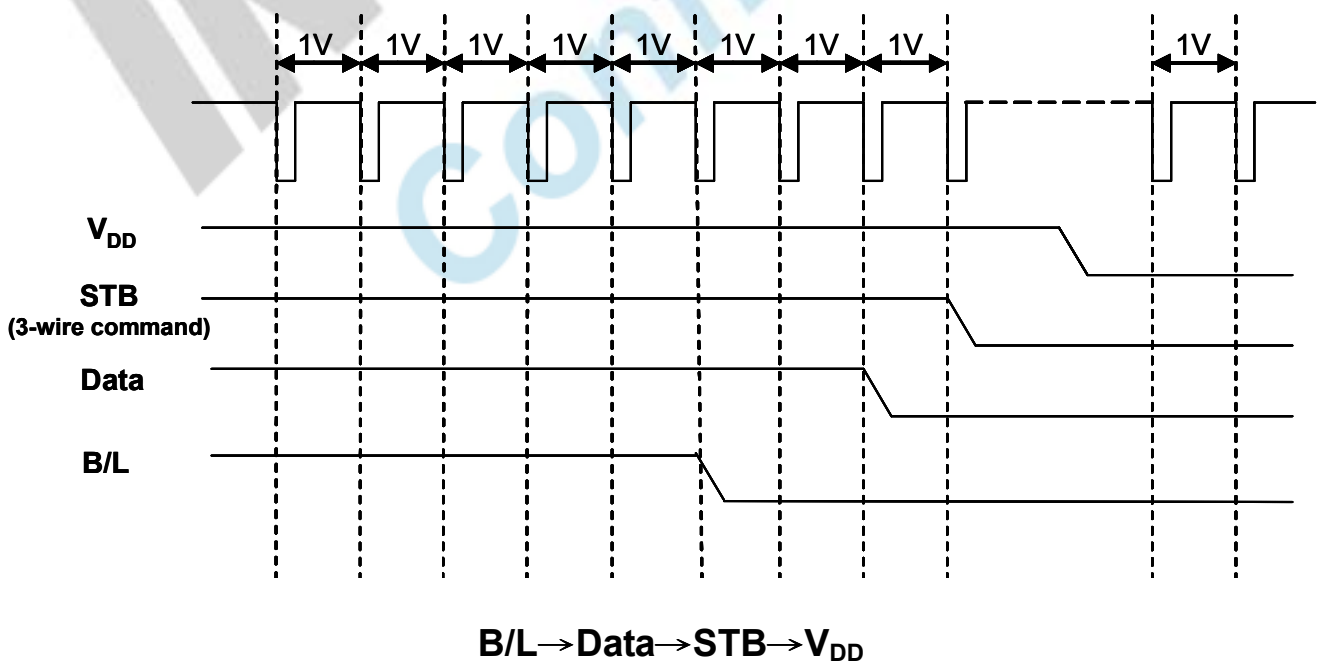

Note: Data include R[5:0],G[5:0],B[5:0],SPENA, SPCK, SPDA, Hsync, Vsync, DCLK, DE.

3.5. Timing Characteristics

3.5.1. AC Electrical Characteristics

3.5.1.1 AC Electrical Characteristics (Test Condition: (V_{DD}=3.3V,GND= 0V, TA= 25°C))

Item	Symbol	Values			Unit.	Remark
		Min.	Typ.	Max.		
System Operation Timing						
V _{DD} power on slew time	TPOR	-	-	1000	us	From 0V to 90% V _{DD}
RESET active pulse width	T _{RST}	40			us	V _{DD} =3.3V
Input / Output Timing						
DCLK clock time	T _{clk}	125	-	-	ns	
Hsync to DCLK	T _{hc}	-	-	1	T _{clk}	
Hsync width	T _{hwh}	1	-	-	T _{clk}	
Vsync width	T _{vwh}	1	-	-	Th	
Hsync period time	Th	-	63.56	-	us	
Vsync setup time	T _{vst}	12	-	-	ns	
Vsync hold time	T _{vhd}	12	-	-	ns	
Hsync setup time	T _{hst}	12	-	-		
Hsync setup time	T _{hhd}	12	-	-	ns	
Data setup time	T _{dsu}	12	-	-	ns	
Data hold time	T _{dhd}	12	-	-	ns	
DE setup time	T _{esu}	12	-	-	ns	
Time that Vsync to 1st linedata input	T _{vs}	2	13	127	Th	

3.5.1.2 Timing Table

18 Bit RGB Mode

ITEM	Symbol	Value			Unit	Remark
		Min.	Typ.	Max.		
DCLK frequency	Fclk	-	6.4	8.0	Mhz	V _{DD} =3.2~3.4V
DCLK cycle time	Tclk	-	156	-	ns	-
DCLK pulse duty	Tcwh	40	50	60	%	Tclk
Time that Hsync to 1'st data input(NTSC)	Ths	40	70	255	-	

3.5.1.3 3-wire serial communication AC timing

Item	Symbol	Values			Unit	Remark
		Min.	Typ.	Max.		
Serial clock	Tspck	320	-	-	ns	
SPCK pulse duty	-	40	50	60	%	
Serial data setup time	Tisu	120	-	-	ns	
Serial data hold time	Tihd	120	-	-	ns	
Serial clock high/low	Tckh/l	120	-	-	ns	
Chip select distinguish	Tcd	1	-	-	us	
SPENB to Vsync	Tcv	1	-	-	us	
SPENB setup time	Teck	150	-	-	ns	
SPENB hold time	Tcke	150	-	-	ns	

3.5.2. Timing Diagram

Input Data Timing

1. Clock and Data Input Timing Diagram

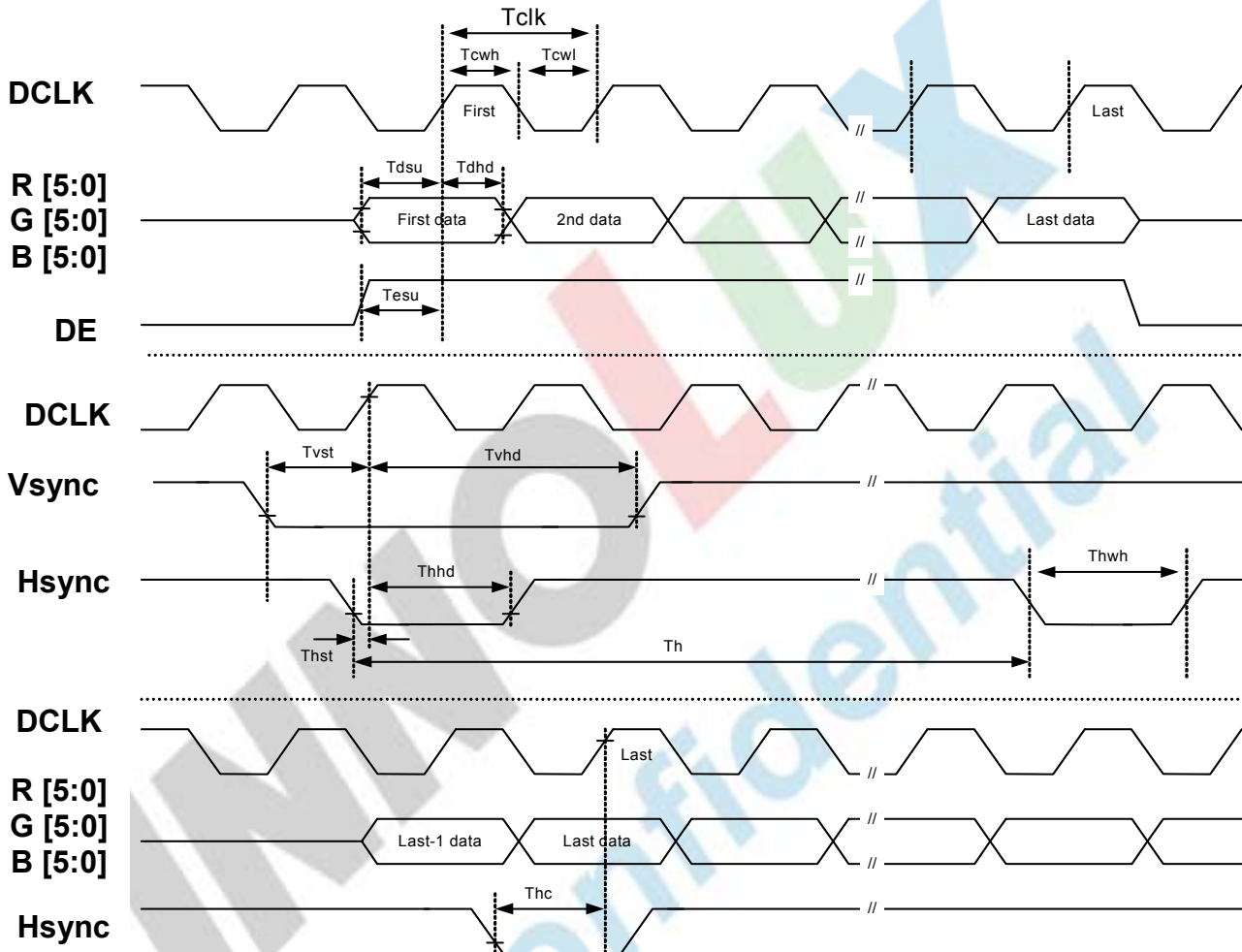

Note: 3-Wire Writer Format:

MSB											LSB				
D15	D14	D13	D12	D11	D10	D9	D8	D7	D6	D5	D4	D3	D2	D1	D0
Register Address[5:0]							1	X	DATA(Issue by external controller)						

D9 : W/R control bit. "1" for Write ; "0" for Read

D8 : Hi-Z bit during read mode

Note: 3-Wire Control Registers List

3-Wire Register		Register Description		
D[15:10]	Name	Init	R/W	Function Description
000000b	R00	07h	R/W	System control register
000001b	R01	00h	R/W	Timing controller function register
000010b	R02	03h	R/W	Operation control register
000011b	R03	CCh	R/W	Input data format control register
000100b	R04	46h	R/W	Source Timing delay control register
000101b	R05	0Dh	R/W	Gate Timing delay control register
000110b	R06	00h	R/W	Reserved
000111b	R07	00h	R/W	Internal function control register
001000b	R08	08h	R/W	RGB contrast control register
001001b	R09	40h	R/W	RGB brightness control register
001010b	R0A	88h	R/W	Hue/Saturation control register
001011b	R0B	88h	R/W	R/B Sub-contrast control register
001100b	R0C	20h	R/W	R Sub-brightness control register
001101b	R0D	20h	R/W	B Sub-brightness control register

3.5.3. Reference circuit

the positive(VGH) and negative(VGL) power supplies for LCD are generated through build-in DC-DC charge pump circuit, an elegant design with only several passive power-setting capacitors are required.

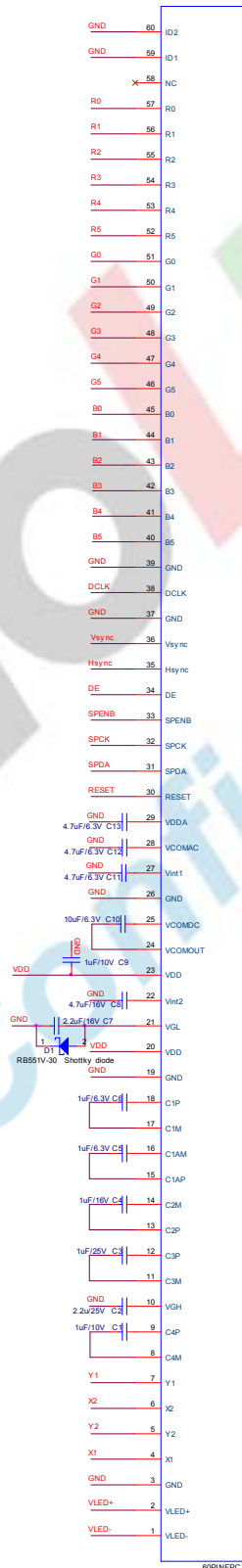

版權屬於群創所有，禁止任何未經授權的使用

4. Touch Screen Panel Specifications

4.1. Electrical Characteristics

Item	Value			Unit	Remark
	Min.	Typ.	Max.		
Linearity	-1.5	-	1.5	%	Analog X and Y directions
Terminal Resistance	160	-	840	Ω	X(Film side)
	160	-	640	Ω	Y(Glass side)
Insulation resistance	25	-	-	MΩ	DC 25V
Voltage	-	5	7	V	DC
Chattering	-	-	10	ms	100kΩ pull-up
Transparency	80	-	-	%	JIS K7105

Note: Avoid operating with hard or sharp material such as a ball point pen or a mechanical pencil except a polyacetal pen (tip R0.8mm or less) or a finger.

4.2. Mechanical & Reliability Characteristics

Item	Value			Unit	Remark
	Min.	Typ.	Max.		
Activation force	80	-	-	gf	Note 1
Durability-surface scratching	Write 100,000	-	-	characters	Note 2
Durability-surface pitting	1,000,000	-	-	touches	Note 3
Surface hardness	3	-	-	H	JIS K5400

Note 1: Activation force test condition

- (1) Input DC 5V on X direction, Drop off Polyacetal Stylus (R0.8), until output voltage stabilize ,then get the activation force ◦
- (2) R8.0mm Silicon rubber for finger Activation force test
- (3) Test point: 9 points

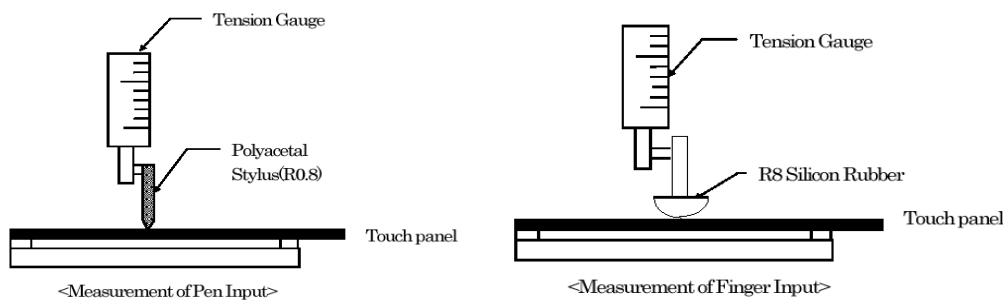

Note 2: Measurement for surface area.

- Scratch 100,000 times straight line on the film with a stylus change every 20,000 times.
- Force: 250gf.
- Speed: 60mm/sec.
- Stylus: R0.8 polyacetal tip.

Note 3: Pit 1,000,000 times on the film with a R0.8 silicon rubber.

- Force: 250gf.
- Speed: 2times/sec.

4.3. Linearity Definition

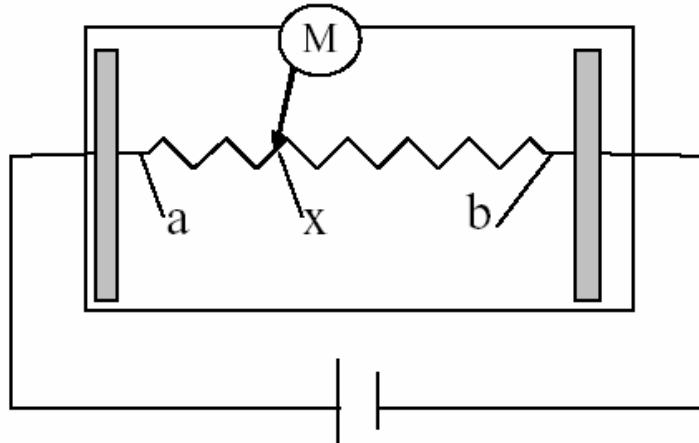

- Va: maximum voltage in the active area of touch panel
- Vb: minimum voltage in the active area of touch panel
- X: random measuring point
- Vxm: actual voltage of Lx point
- Vxi: theoretical voltage of Lx point

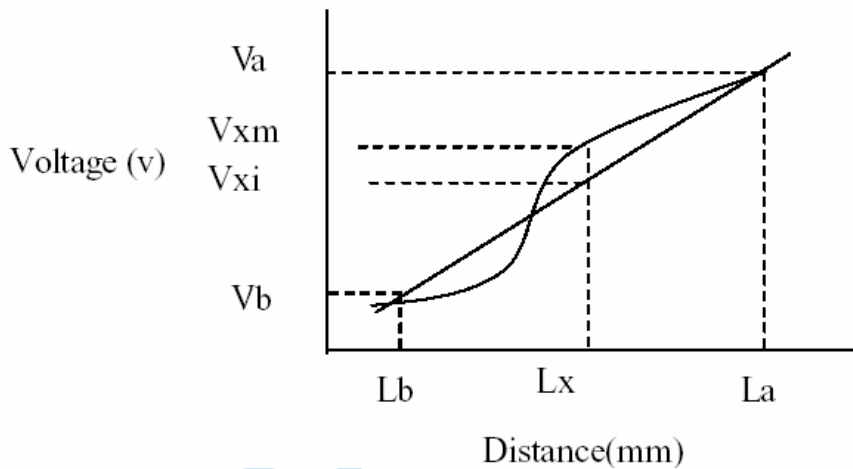

$$\text{Linearity} = \frac{|Vxi - Vxm|}{(Va - Vb)} * 100\%$$

Note: Test area is as follows and operation force is 150gf.

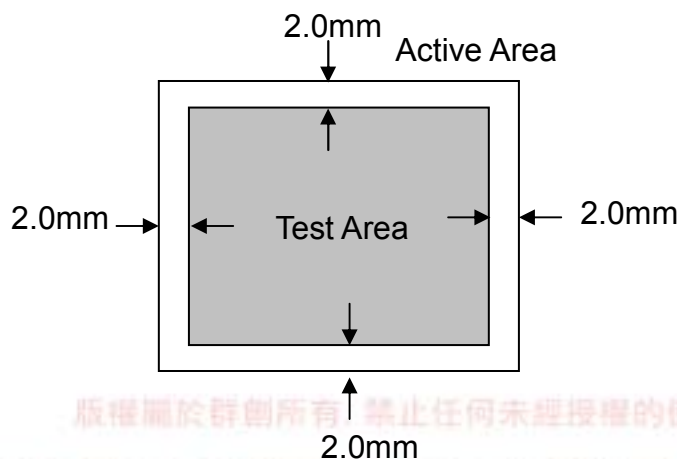

版權屬於群創所有 禁止任何未經授權的使用

4.4. Housing design guide

Housing design follow as below

- 1) Avoid the design that housing overlap and press on the active area of the LCM
- 2) Give enough gap(over 0.5mm at compressed) between the housing and TSP to protect wrong operating.

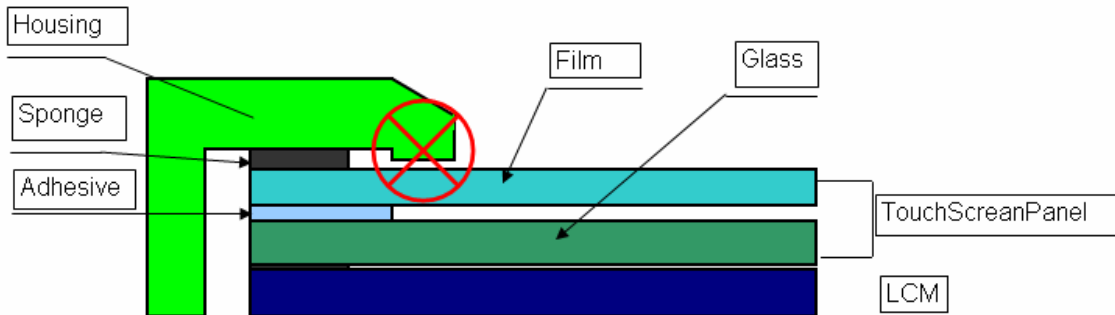

- 3) Use a buffer material(Gasket) between the TSP and housing to protect damage and wrong operating
- 4) Avoid the design that buffer material overlap and press on the inside of TSP view area

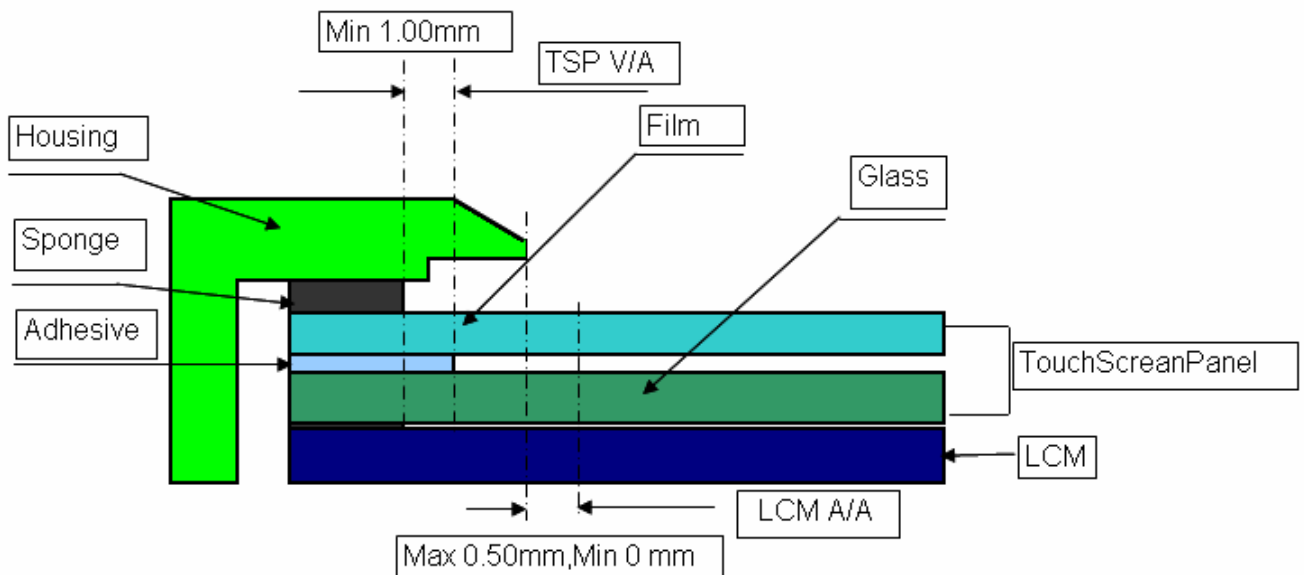

5. Optical Specifications

Item	Symbol	Condition	Values			Unit	Remark
			Min.	Typ.	Max.		
Viewing angle (CR≥ 10)	θ_L	$\Phi=180^\circ$ (9 o'clock)	55	65	-	degree	Note 1 Note 7
	θ_R	$\Phi=0^\circ$ (3 o'clock)	55	65	-		
	θ_T	$\Phi=90^\circ$ (12 o'clock)	40	50	-		
	θ_B	$\Phi=270^\circ$ (6 o'clock)	55	65	-		
Response time	T_{ON}	Normal $\theta=\Phi=0^\circ$	-	9	20	msec	Note 3
	T_{OFF}		-	16	30	msec	Note 3
Contrast ratio	CR		400	500	-	-	Note 4
Color chromaticity	W_X	Normal $\theta=\Phi=0^\circ$	0.26	0.31	0.36	-	Note 2 Note 5
	W_Y		0.28	0.33	0.38	-	Note 6 Note 7
Luminance	L		300	350	-	cd/m ²	Note 6
Luminance uniformity	Y_U		70	75	-	%	Note 8

Test Conditions:

1. $V_{DD}=3.3V$, $I_L=20mA$ (Backlight current), the ambient temperature is 25°C.
2. The test systems refer to Note 2.

Note 1: Definition of viewing angle

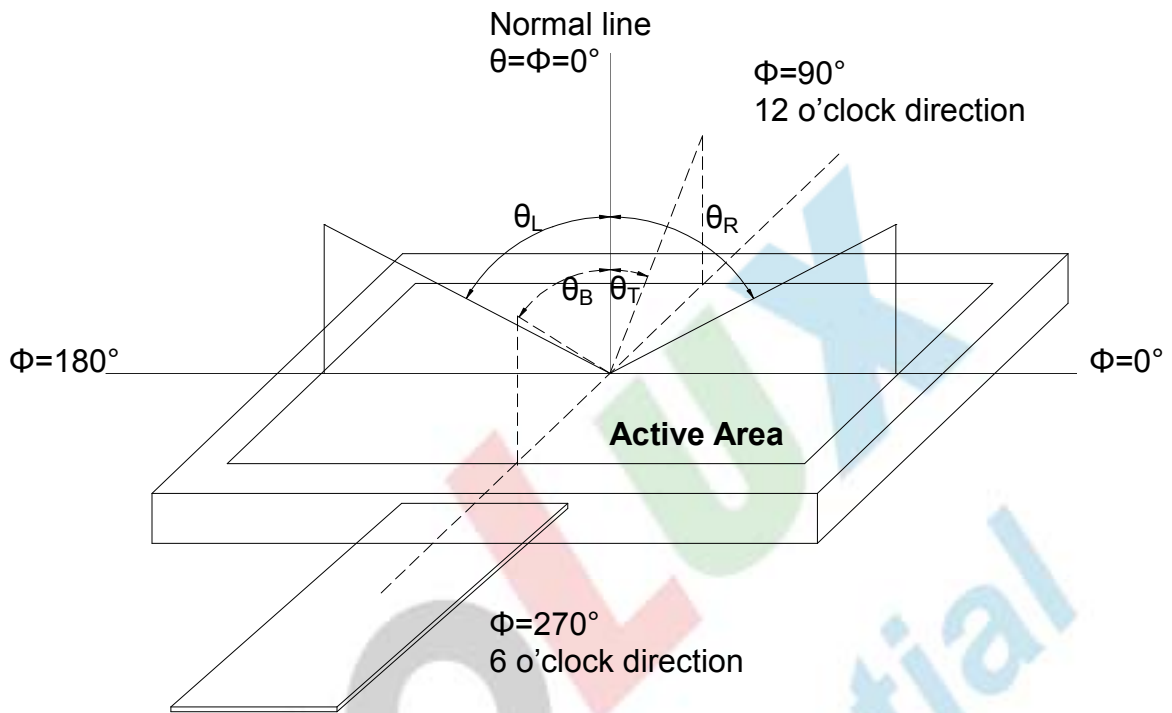

Fig. 5-1 Definition of viewing angle

Note 2: Definition of optical measurement system.

The optical characteristics should be measured in dark room. The optical properties are measured at the center point of the LCD screen. (Response time is measured by Photo detector TOPCON BM-7, other items are measured by BM-5A/Field of view: 1° /Height: 500mm.)

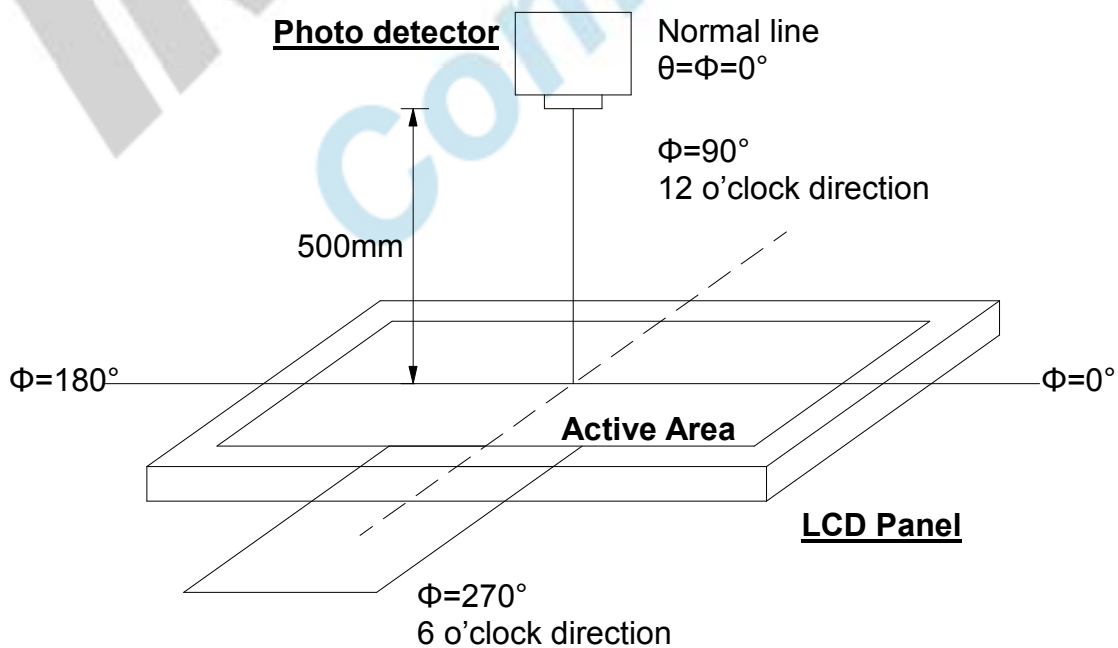

Fig. 5-2 Optical measurement system setup

Note 3: Definition of Response time

The response time is defined as the LCD optical switching time interval between "White" state and "Black" state. Rise time (T_{ON}) is the time between photo detector output intensity changed from 90% to 10%. And fall time (T_{OFF}) is the time between photo detector output intensity changed from 10% to 90%.

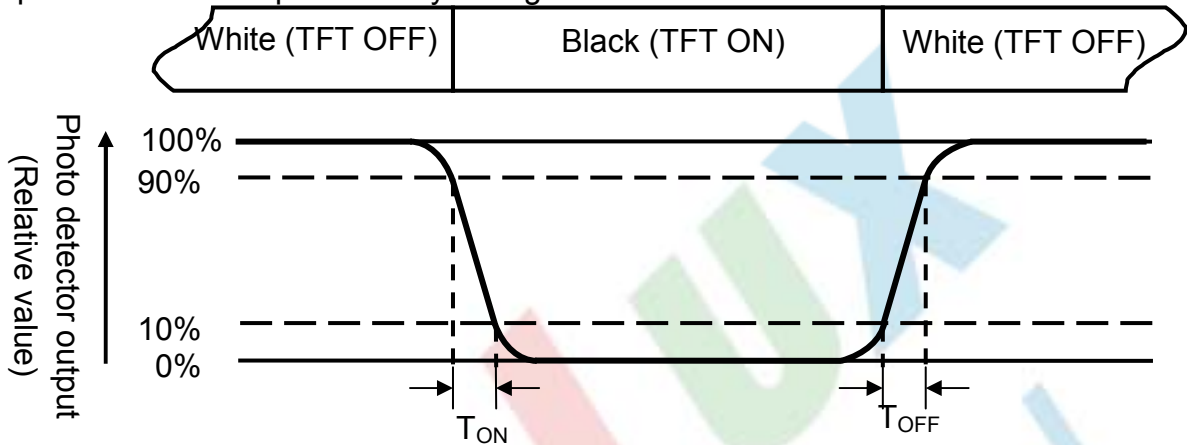

Fig. 5-3 Definition of response time

$$T_{ON} + T_{OFF} \leq 25 \text{ ms}$$

Note 4: Definition of contrast ratio

$$\text{Contrast ratio (CR)} = \frac{\text{Luminance measured when LCD is on the "White" state}}{\text{Luminance measured when LCD is on the "Black" state}}$$

Note 5: Definition of color chromaticity (CIE1931)

Color coordinates measured at center point of LCD.

Note 6: All input terminals LCD panel must be ground when measuring the center area of the panel. The LED driving condition is $I_L=20\text{mA}$.

Note 7 :The values should be measured without Touch Screen Panel.

Note 8: Definition of Luminance Uniformity

To test for uniformity, the tested area, which is inside the active area, is divided into 3 rows and 3 columns. The measurement spot is placed at the center of each box.

$$\text{Luminance Uniformity (Yu)} = \frac{B_{min}}{B_{max}}$$

L-----Active area length W----- Active area width

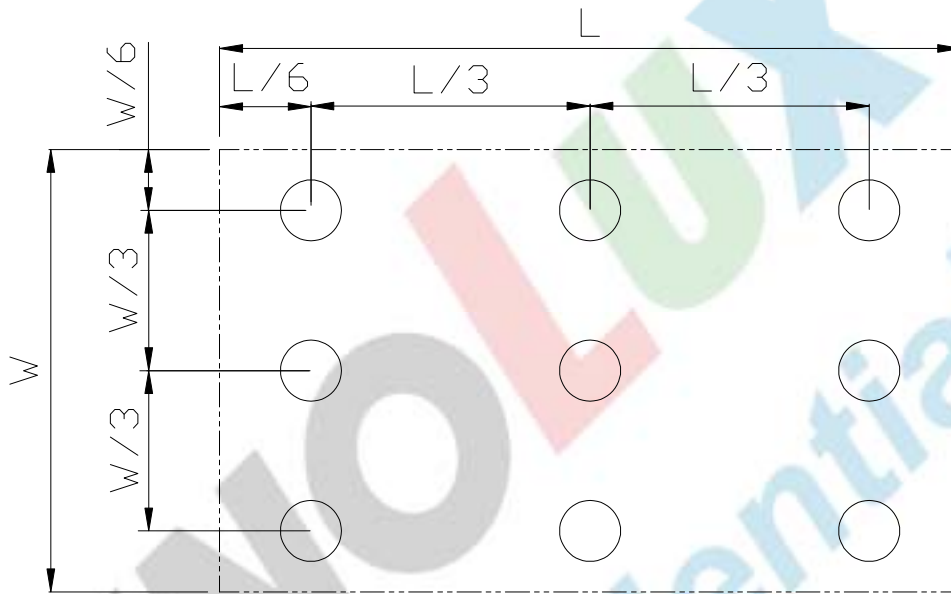

Fig. 5-4 Definition of uniformity

B_{max}: The measured maximum luminance of all measurement position.

B_{min}: The measured minimum luminance of all measurement position.

6. Reliability Test Items

(Note3)

Item	Test Conditions	Remark
High Temperature Storage	Ta = 80°C 240 hrs	Note 1,Note 4
Low Temperature Storage	Ta = -30°C 240hrs	Note 1,Note 4
High Temperature Operation	Ts = 70°C 240hrs	Note 2,Note 4
Low Temperature Operation	Ta = -20°C 240hrs	Note 1,Note 4
Operate at High Temperature and Humidity	+60°C, 90%RH 240 hrs	Note 5
Thermal Shock	-30°C/30 min ~ +80°C/30 min for a total 100 cycles, Start with cold temperature and end with high temperature	Note 4
Vibration Test	Frequency range:10~55Hz Stroke:1.5mm Sweep:10Hz~55Hz~10Hz 2 hours for each direction of X. Y. Z. (6 hours for total)	
Mechanical Shock	100G 6ms,±X, ±Y, ±Z 3 times for each direction	
Package Vibration Test	Random Vibration : 0.015G*G/Hz from 5-200HZ, -6dB/Octave from 200-500HZ 2 hours for each direction of X. Y. Z. (6 hours for total)	
Package Drop Test	Height:60 cm 1 corner, 3 edges, 6 surfaces	
Electro Static Discharge	± 2KV, Human Body Mode, 100pF/1500Ω	

Note 1: Ta is the ambient temperature of samples.

Note 2: Ts is the temperature of panel's surface.

Note 3: In the standard condition, there shall be no practical problem that may affect the display function. After the reliability test, the product only guarantees operation, but doesn't guarantee all the cosmetic specification.

Note 4: Before cosmetic and function test, the product must have enough recovery time, at least 2 hours at room temperature.

Note 5: Before cosmetic and function test, the product must have enough recovery time, at least 24 hours at room temperature.

版權屬於群創所有，禁止任何未經授權的使用

The copyright belongs to InnoLux. Any unauthorized use is prohibited.

7. Handling Precautions

7.1. Safety

Liquid crystal is poisonous. Do not put it in your mouth. If liquid crystal touches your skin or clothes, wash it off immediately by using soap and water.

7.2. Handling

1. The LCD panel is plate glass. Do not subject the panel to mechanical shock or to excessive force on its surface.
2. The polarizer attached to the display is easily damaged. Please handle it carefully to avoid scratch or other damages.
3. To avoid contamination on the display surface, do not touch the module surface with bare hands.
4. Keep a space so that the LCD panels do not touch other components.
5. Put cover board such as acrylic board on the surface of LCD panel to protect panel from damages.
6. Transparent electrodes may be disconnected if you use the LCD panel under environmental conditions where the condensation of dew occurs.
7. Do not leave module in direct sunlight to avoid malfunction of the ICs.

7.3. Static Electricity

1. Be sure to ground module before turning on power or operating module.
2. Do not apply voltage which exceeds the absolute maximum rating value.

7.4. Storage

1. Store the module in a dark room where must keep at $+25\pm 10^{\circ}\text{C}$ and 65%RH or less.
2. Do not store the module in surroundings containing organic solvent or corrosive gas.
3. Store the module in an anti-electrostatic container or bag.

7.5. Cleaning

1. Do not wipe the polarizer with dry cloth. It might cause scratch.
2. Only use a soft sloth with IPA to wipe the polarizer, other chemicals might permanent damage to the polarizer.

8. Mechanical Drawing

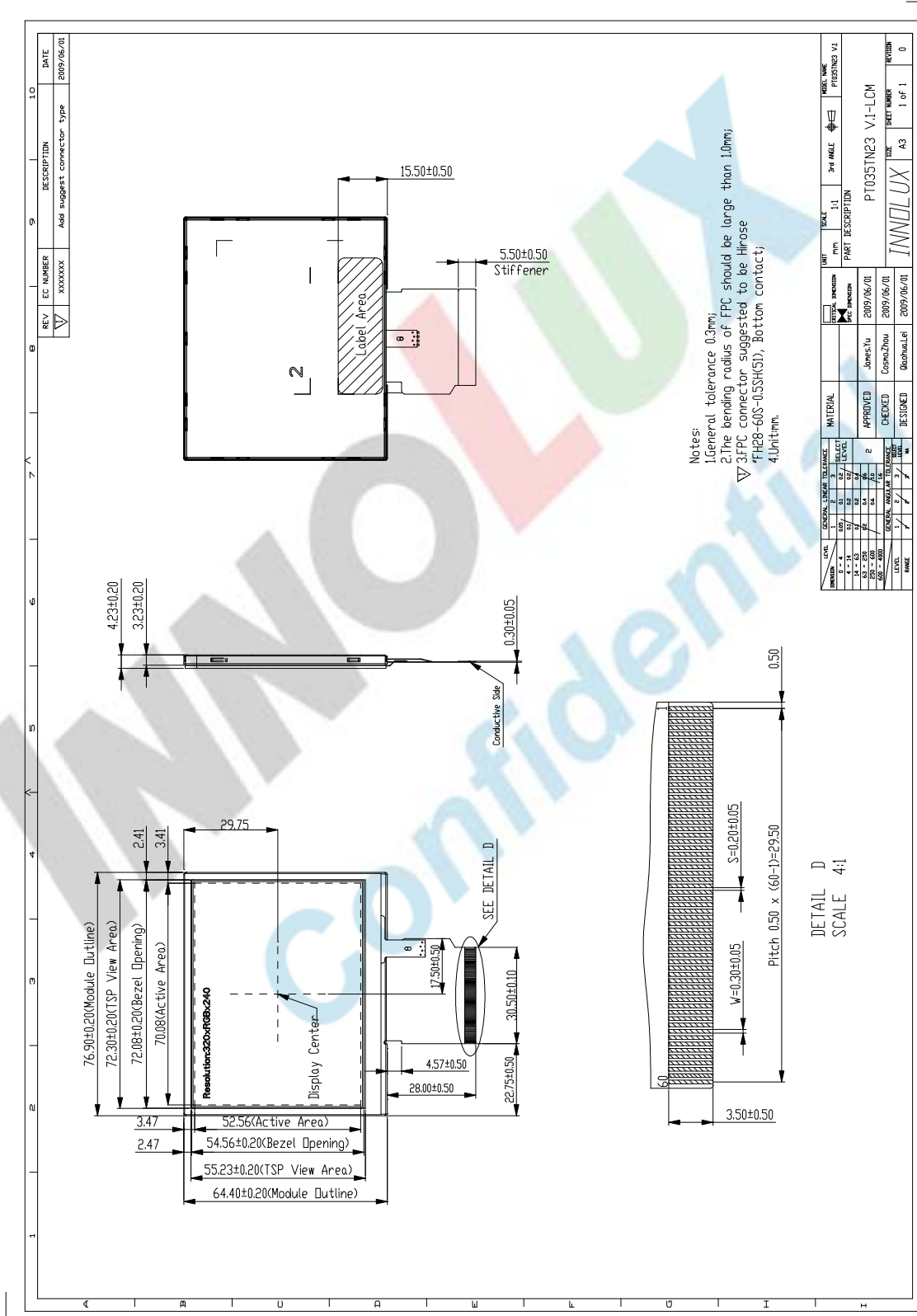

Notes:
 1. General tolerance 0.3mm;
 2. The bending radius of FPC should be large than 10mm;
 3. FPC connector suggested to be Hirose FH28-60S-05SH(5), Bottom contact;
 4. Unit:mm.

REV	EC NUMBER	DESCRIPTION	DATE
1	XXXXXX	Add suggest connector type	2009/06/01

SCALE	1:1	3rd ANGLE	PT035T23 V1
PART DESCRIPTION	PT035T23 V1-LCM		
APPROVED	Jones Yu	2009/06/01	SHEET NUMBER 1 of 1
CHECKED	Cosma Zhou	2009/06/01	
DESIGNED	Wangshu Lei	2009/06/01	

LEVEL	1	GENERAL TOLERANCE	0.3
LEVEL	2	SELECT LEVEL	0.2
LEVEL	3	SELECT LEVEL	0.15
LEVEL	4	SELECT LEVEL	0.1
LEVEL	5	SELECT LEVEL	0.075
LEVEL	6	SELECT LEVEL	0.05
LEVEL	7	SELECT LEVEL	0.04
LEVEL	8	SELECT LEVEL	0.03
LEVEL	9	SELECT LEVEL	0.025
LEVEL	10	SELECT LEVEL	0.02
LEVEL	11	SELECT LEVEL	0.015
LEVEL	12	SELECT LEVEL	0.01
LEVEL	13	SELECT LEVEL	0.0075
LEVEL	14	SELECT LEVEL	0.005
LEVEL	15	SELECT LEVEL	0.004
LEVEL	16	SELECT LEVEL	0.003
LEVEL	17	SELECT LEVEL	0.0025
LEVEL	18	SELECT LEVEL	0.002
LEVEL	19	SELECT LEVEL	0.0015
LEVEL	20	SELECT LEVEL	0.001
LEVEL	21	SELECT LEVEL	0.00075
LEVEL	22	SELECT LEVEL	0.0005
LEVEL	23	SELECT LEVEL	0.0004
LEVEL	24	SELECT LEVEL	0.0003
LEVEL	25	SELECT LEVEL	0.00025
LEVEL	26	SELECT LEVEL	0.0002
LEVEL	27	SELECT LEVEL	0.00015
LEVEL	28	SELECT LEVEL	0.0001
LEVEL	29	SELECT LEVEL	0.000075
LEVEL	30	SELECT LEVEL	0.00005
LEVEL	31	SELECT LEVEL	0.00004
LEVEL	32	SELECT LEVEL	0.00003
LEVEL	33	SELECT LEVEL	0.000025
LEVEL	34	SELECT LEVEL	0.00002
LEVEL	35	SELECT LEVEL	0.000015
LEVEL	36	SELECT LEVEL	0.00001
LEVEL	37	SELECT LEVEL	0.0000075
LEVEL	38	SELECT LEVEL	0.000005
LEVEL	39	SELECT LEVEL	0.000004
LEVEL	40	SELECT LEVEL	0.000003
LEVEL	41	SELECT LEVEL	0.0000025
LEVEL	42	SELECT LEVEL	0.000002
LEVEL	43	SELECT LEVEL	0.0000015
LEVEL	44	SELECT LEVEL	0.000001
LEVEL	45	SELECT LEVEL	0.00000075
LEVEL	46	SELECT LEVEL	0.0000005
LEVEL	47	SELECT LEVEL	0.0000004
LEVEL	48	SELECT LEVEL	0.0000003
LEVEL	49	SELECT LEVEL	0.00000025
LEVEL	50	SELECT LEVEL	0.0000002
LEVEL	51	SELECT LEVEL	0.00000015
LEVEL	52	SELECT LEVEL	0.0000001
LEVEL	53	SELECT LEVEL	0.000000075
LEVEL	54	SELECT LEVEL	0.00000005
LEVEL	55	SELECT LEVEL	0.00000004
LEVEL	56	SELECT LEVEL	0.00000003
LEVEL	57	SELECT LEVEL	0.000000025
LEVEL	58	SELECT LEVEL	0.00000002
LEVEL	59	SELECT LEVEL	0.000000015
LEVEL	60	SELECT LEVEL	0.00000001
LEVEL	61	SELECT LEVEL	0.0000000075
LEVEL	62	SELECT LEVEL	0.000000005
LEVEL	63	SELECT LEVEL	0.000000004
LEVEL	64	SELECT LEVEL	0.000000003
LEVEL	65	SELECT LEVEL	0.0000000025
LEVEL	66	SELECT LEVEL	0.000000002
LEVEL	67	SELECT LEVEL	0.0000000015
LEVEL	68	SELECT LEVEL	0.000000001
LEVEL	69	SELECT LEVEL	0.00000000075
LEVEL	70	SELECT LEVEL	0.0000000005
LEVEL	71	SELECT LEVEL	0.0000000004
LEVEL	72	SELECT LEVEL	0.0000000003
LEVEL	73	SELECT LEVEL	0.00000000025
LEVEL	74	SELECT LEVEL	0.0000000002
LEVEL	75	SELECT LEVEL	0.00000000015
LEVEL	76	SELECT LEVEL	0.0000000001
LEVEL	77	SELECT LEVEL	0.000000000075
LEVEL	78	SELECT LEVEL	0.00000000005
LEVEL	79	SELECT LEVEL	0.00000000004
LEVEL	80	SELECT LEVEL	0.00000000003
LEVEL	81	SELECT LEVEL	0.000000000025
LEVEL	82	SELECT LEVEL	0.00000000002
LEVEL	83	SELECT LEVEL	0.000000000015
LEVEL	84	SELECT LEVEL	0.00000000001
LEVEL	85	SELECT LEVEL	0.0000000000075
LEVEL	86	SELECT LEVEL	0.000000000005
LEVEL	87	SELECT LEVEL	0.000000000004
LEVEL	88	SELECT LEVEL	0.000000000003
LEVEL	89	SELECT LEVEL	0.0000000000025
LEVEL	90	SELECT LEVEL	0.000000000002
LEVEL	91	SELECT LEVEL	0.0000000000015
LEVEL	92	SELECT LEVEL	0.000000000001
LEVEL	93	SELECT LEVEL	0.00000000000075
LEVEL	94	SELECT LEVEL	0.0000000000005
LEVEL	95	SELECT LEVEL	0.0000000000004
LEVEL	96	SELECT LEVEL	0.0000000000003
LEVEL	97	SELECT LEVEL	0.00000000000025
LEVEL	98	SELECT LEVEL	0.0000000000002
LEVEL	99	SELECT LEVEL	0.00000000000015
LEVEL	100	SELECT LEVEL	0.0000000000001

DETAIL D
SCALE 4:1

版權屬於群創所有，禁止任何未經授權的使用

The copyright belongs to InnoLux. Any unauthorized use is prohibited.

9. Package Drawing

9.1. Packaging Material Table

No.	Item	Model (Material)	Dimensions (mm)	Unit Weight (kg)	Quantity (pcs)	Remark
1	LCM Module	PT035TN23 V.1	76.9 × 64.4 × 4.23	0.043	180	
2	Tray	PET	505 x 338 x 16.5	0.180	16	Anti-static
3	Dust-Proof Bag	PE	700 x 530	0.050	1	
4	Partition	Corrugated Paper	512 x 350 x 225	0.290	1	
5	Carton	Corrugated Paper	530 x 355 x 255	0.810	1	
6	Total Weight	11.770±5% kg				

9.2. Packaging Quantity

(1) LCM quantity per tray :	3 row x 4 column = 12 pcs
(2) Total LCM quantity of per Carton:	15 pcs/ tray x 12 pcs / tray = 180 pcs

9.3. Packaging Drawing

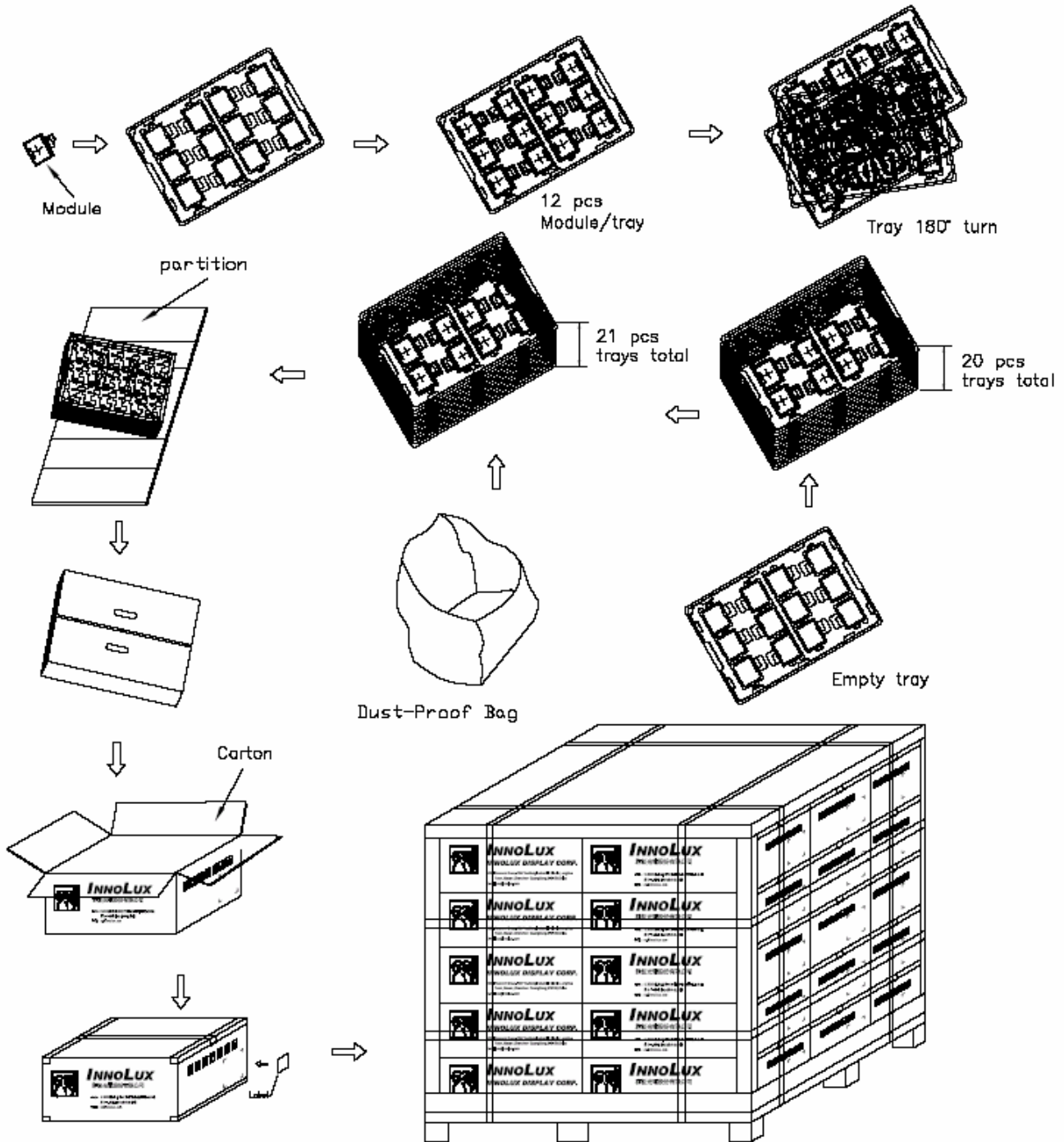

版權屬於群創所有，禁止任何未經授權的使用

The copyright belongs to InnoLux. Any unauthorized use is prohibited.