

mass integrated

global part distribution • product lifecycle partner
excess inventory management • value-ad service provider



Data sheet provided by Mass Integrated

massintegrated.com • displayalliance.com

Please call +1.978.465.6190
Email: sales@massintegrated.com



ISO 9001: 2008

Mass Integrated complies with all DMCA takedown notices. Please send a formal DMCA Takedown Notice to Mass Integrated Systems, Inc. • 18 Henry Graf Jr. Road, Unit 1 • Newburyport, MA 01950.

HITACHI

KAOHSIUNG HITACHI
ELECTRONICS CO.,LTD
P.O. BOX 26-27
2,13TH EAST ST. K.E.P.Z.
KAOHSIUNG TAIWAN R.O.C.
TEL:(07) 8211101(10 LINE)
TELEX:81903 KHE
FAX:(07) 821-5860

FOR MESSRS.: _____

DATE. Nov.13,2008

CUSTOMER'S ACCEPTANCE SPECIFICATIONS SP12N001-T C O N T E N T S

No.	ITEM	SHEET No.	PAGE
1	Cover	7B64PS 2701- SP12N001-T-3	1-1/1
2	Record Of Revision	7B64PS 2702- SP12N001-T-3	2-1/1
3	General Specification	7B64PS 2703- SP12N001-T-3	3-1/1
4	Mechanical Data		
5	Absolute Maximum Ratings	7B64PS 2704- SP12N001-T-3	4-1/1
6	Electrical Characteristics	7B64PS 2705- SP12N001-T-3	5-1/1
7	Optical Characteristics		
8	Dimensional Outline	7B64PS 2706- SP12N001-T-3	6-1/3~6-3/3
9	Block Diagram		
10	Interface Timing Chart	7B64PS 2707- SP12N001-T-3	7-1/1
11	Power Supply For LCM	7B64PS 2708- SP12N001-T-3	8-1/1
12	Power And Interface Timing Sequence		

ACCEPTED BY; _____

PROPOSED BY; *Elton Liu*

RECORD OF REVISION

DATE	SHEET No.	SUMMARY
May.29,'02	7B64PS 2703 SP12N001-T-2 PAGE 3-1/1	CHANGED: 3.MECHANICAL DATA (10)LCD Controller IC LC7982A → LC7981
	7B64PS 2707 SP12N001-T-2 PAGE 7-1/1	CHANGED: 10.TIMING CHARACTERISTICS Ta=-20 to 75°C → Ta=0 to 50°C
	7B64PS 2708 SP12N001-T-2 PAGE 8-1/1	CHANGED: 12.POWER AND INTERFACE TIMING SEQUENCE Note : controller LC7982A → LC7981
Nov.13,'08	7B64PS 2703 SP12N001-T-3 PAGE 3-1/1	Changed : 4.MECHANICAL DATA (9) EL NO.NEL-5LL-715-W → C180-W620-A2 Maker : NEC → SOD

3.GENERAL SPECIFICATIONS.

3.1 Standard Specifications

3284PS 2501 – 401 – 1

This individual specifications is prior to general specification.

Note 1. No HITACHI mark, No. ITEM No. be printed on PCB.

4. MECHANICAL DATA

(1) Number Of Dots	256 (W) × 64 (H) DOTS
(2) Module Size	160.0 (W) × 68.0 (H) × 9.5 (D) (MAX.) mm
(3) Effective Display Area	126.3 (W) × 37.0 (H) mm
(4) Dot Size	0.44 (W) × 0.44 (H) mm
(5) Dot Pitch	0.47 (W) × 0.47 (H) mm
(7) Viewing Direction	6 O'clock
(8) LCD Type	New gray mode with EL backlight lighting color white
(9) EL	No.C180-W620-A2 Maker.: SOD
(10) LCD Controller IC	LC7981/SANYO

5. ABSOLUTE MAXIMUM RATINGS

5.1 Electrical Absolute Maximum Ratings.

ITEM	SYMBOL	MIN.	TYP.	MAX.	UNIT	COMMENT
Power Supply For Logic	VDD - VSS	0	-	7.0	V	
Power Supply For Drive	VDD - VEE	0	-	22.0	V	
Input Voltage	VI	VSS	-	VDD	V	
Static Electricity	-	-	-	100	V	
EL Power Supply	VEL	-	-	AC150	Vrms	
	fEL	50	-	1000	HZ	AC100Vrms

5.2 Environmental Absolute Maximum Ratings.

ITEM	OPERATING		STORAGE		COMMENT
	MIN.	MAX.	MIN.	MAX.	
Ambient Temperature	0°C	40°C	-20°C	60°C	Note(2,3)
Humidity	NOTE (1)		NOTE (1)		Without Condensation
Vibration	-	4.9m/S ² (0.5G)	-	19.6m/S ² (2G)	XYZ Direction
Shock	-	29.4m/S ² (3G)	-	490.0m/S ² (50G)	
Corrosive Gas	Not Acceptable		Not Acceptable		

Note (1) $T_a \leq 40^\circ\text{C}$: 85%RH max.

$T_a > 40^\circ\text{C}$: Absolute humidity must be lower than the humidity of 85%RH at 40°C.

Note (2) T_a AT - 20°C < 48hr.

Note (3) Background color of LCD changes depending on temperature

0°C : PURPLISH - GRAY



25°C : GREENISH - GRAY



40°C : GREEN - GRAY

40°C ~ 50°C : No permanent damage

6. ELECTRICAL CHARACTERISTICS

ITEM	SYMBOL	CONDITION	MIN.	TYP.	MAX.	UNIT
Logic Circuit Power Supply Voltage	VDD - VSS	-	4.75	5.0	5.25	V
LC Driver Circuit Power Supply Voltage	VEE - VSS	-	-12.5	-13.0	-13.5	V
Input Voltage Note (1)	H ViH	-	0.8 x VDD	-	VDD	V
	L ViL	-	0	-	0.2 x VDD	V
Input Leak Current	Iin		-5.0	-	5.0	μA
Output Leak Current	Iout		-10.0	-	10.0	
Clock Frequency Note (2)	fCL2		-	-	1.2	MHz
Power Consumption	PW	VDD = 5.0V Ta = 25°C	-	-	250	mW
Recommended LC Driving Voltage Note (3)	VDD - V0 θ = 0° φ = 10°	Ta = 0°C	-	16.2	-	V
		Ta = 25°C	-	15.3	-	
		Ta = 40°C	-	14.7	-	
EL Power Supply Note (4)	VEL	fEL = 400HZ	-	100	-	Vrms
	I _{EL}	VEL = 100Vrms fEL = 400HZ	-	-	100	mArms

Note (1) Applied to DB0~DB7, \overline{CS} , E, RW, RS.

Note (2) Internal clock

Note (3) Recommended LC driving voltage may fluctuate about +/-0.5V by each module.

Note (4) Recommended EL Inverter : NEL - D32 - 48. Maker : NEC

7. OPTICAL DATA

Ta=25°C VDD=5.0V VEE=-13.0V VDD-V0=15.3V

ITEM	SYMBOL	CONDITION	MIN.	TYP.	MAX.	UNIT	NOTE
Viewing Area	φ2 - φ1	K=1.4	-	40	-	deg.	1
Contrast Ratio	K	φ = 10° θ = 0°	-	3.0	-	-	1
Response Time	tr(rise)	φ = 10° θ = 0°	-	250	400	ms	1
	tf(fall)	φ = 10° θ = 0°	-	300	450	ms	1
EL Brightness	BEL	φ = 10° θ = 0°	-	10.0	-	cd / m ²	1

NOTE (1) See general specifications for definition of optical characteristics.

8.DIMENSIONAL OUTLINE

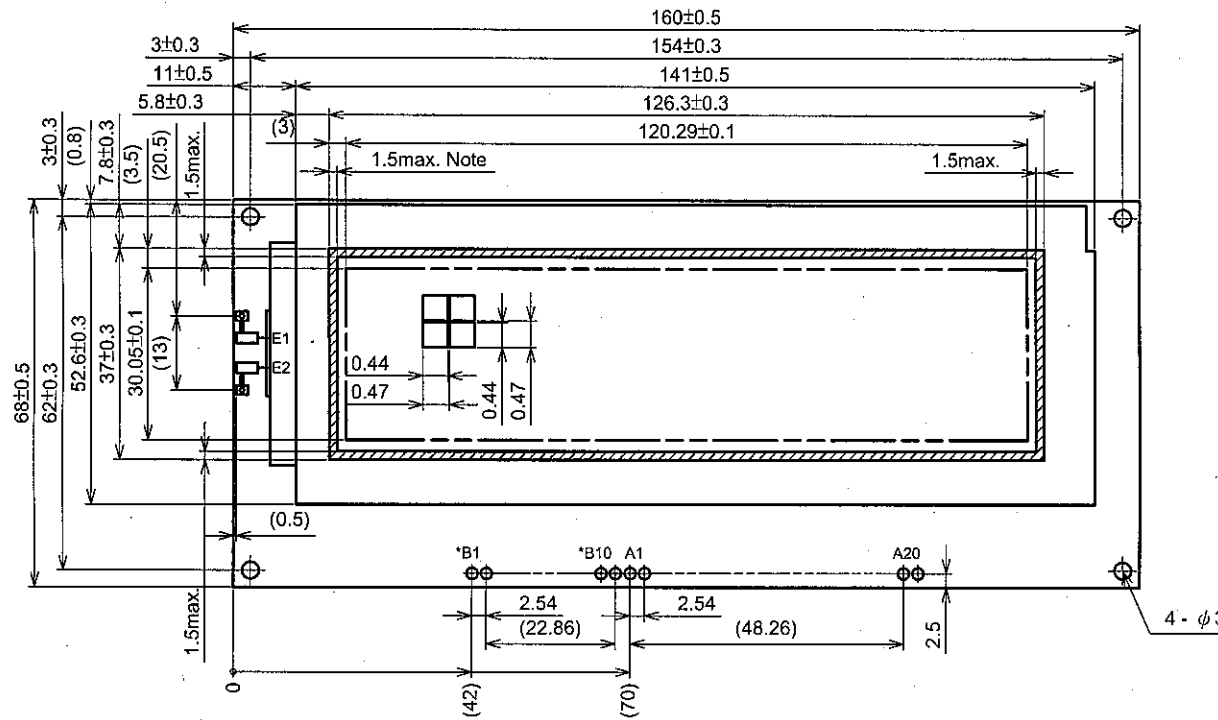

Viewing Direction

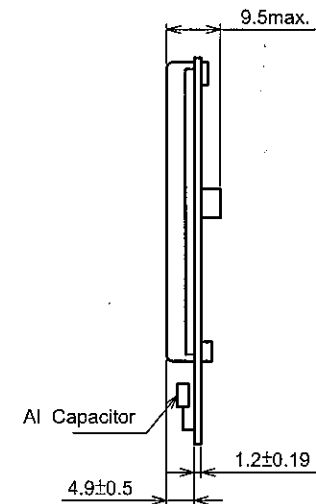

Note: EL sealing area
 *B1 ~ B10 pads should not be used. Do not connect any signals to these pads.
 Use pin no A1 ~ A20 for interface.

Note (1) Detail drawing of matrix pattern

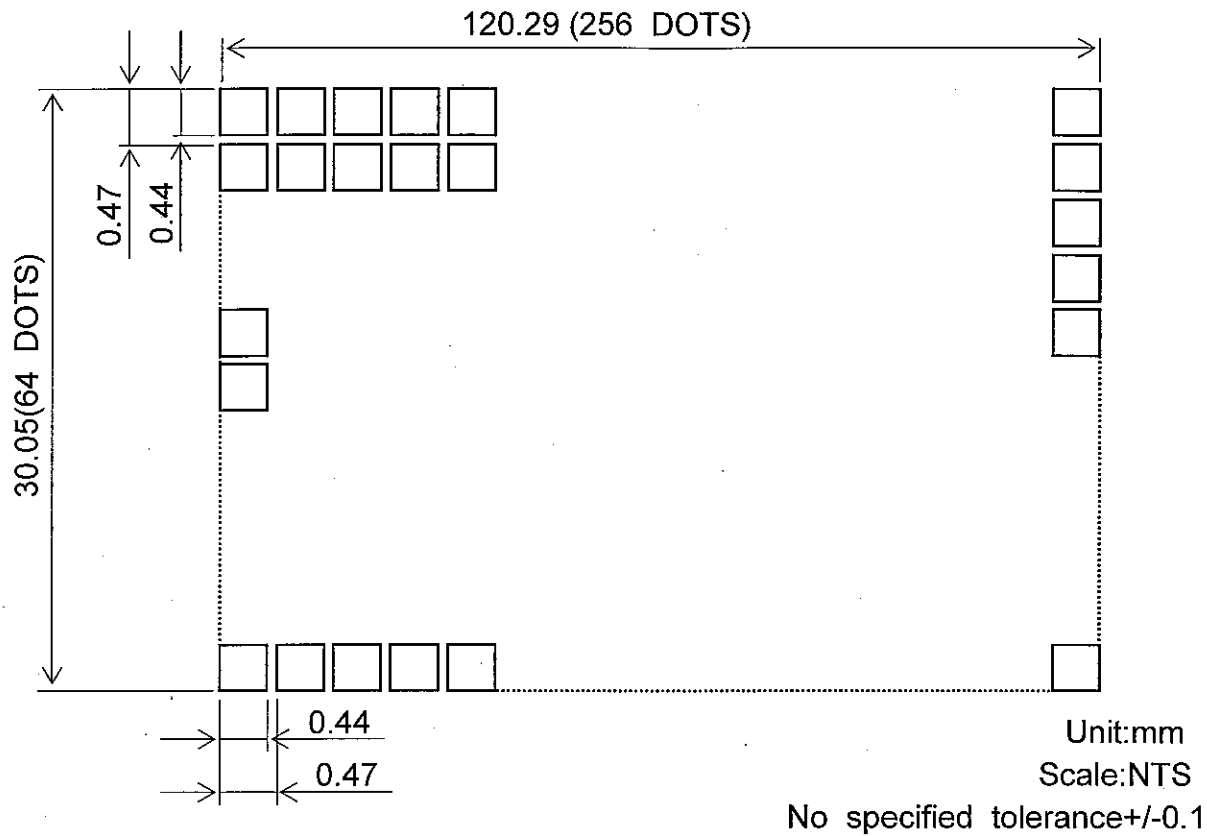

Note (2) Internal pin connection

PIN No.	SYMBOL	FUNCTION
A1	VSS	Ground
A2	VDD	Power Supply For Logic
A3	V0	Power Supply For LCD Drive
A4	RS	Register Select
A5	R/W	Read/Write
A6	E	Enable
A7~14	DB0~DB7	Data Bus
A15	$\overline{\text{CS}}$	Chip Select
A16	$\overline{\text{RES}}$	Reset
A17	VEE	Power Supply For LCD
A18~20	NC	No Connection
E1	VEL	EL Driving Voltage
E2	VEL	EL Driving Voltage

9.BLOCK DIAGRAM

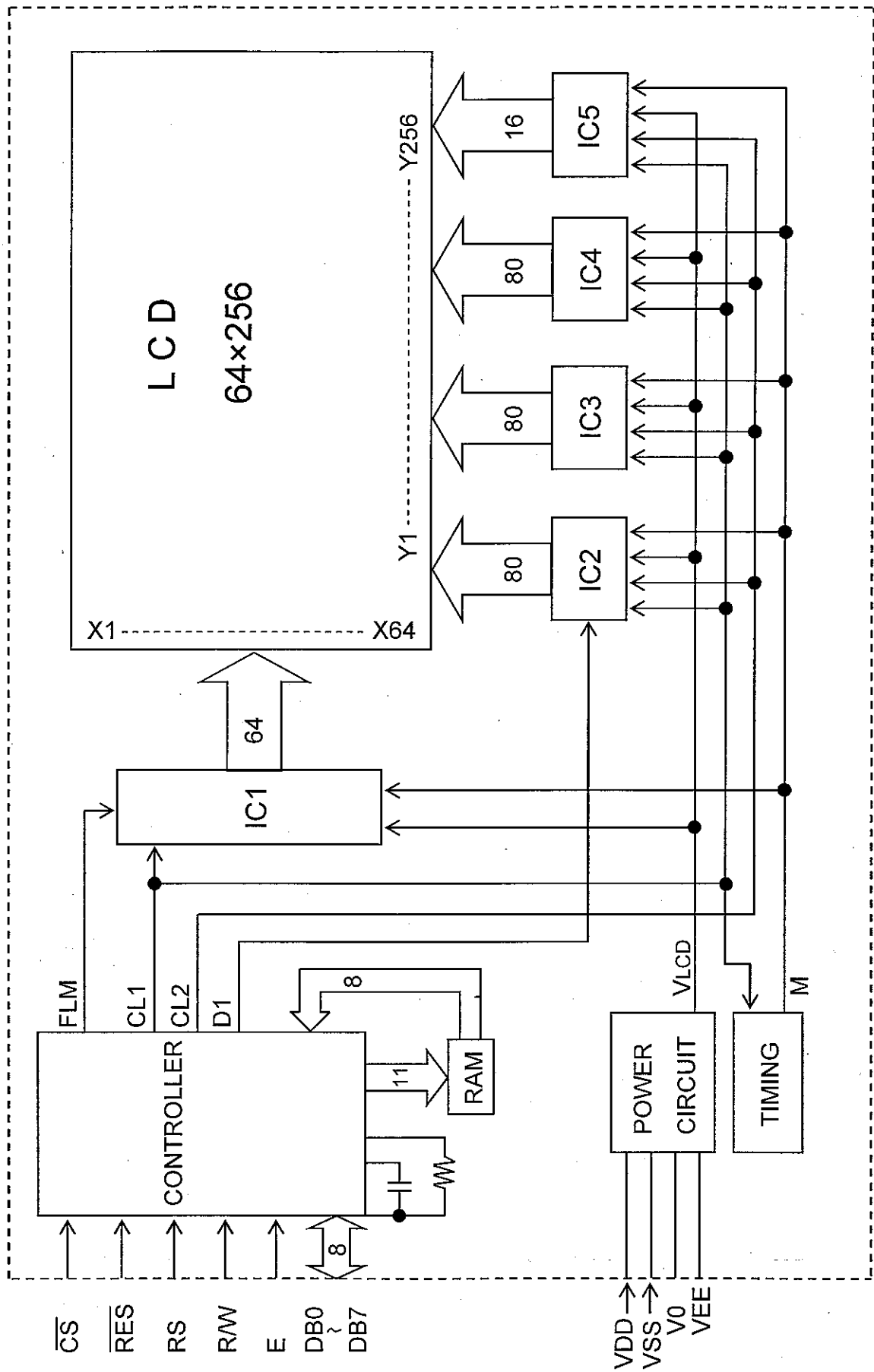

10. TIMING CHARACTERISTICS

- Bus read / write operation 1

Read cycle

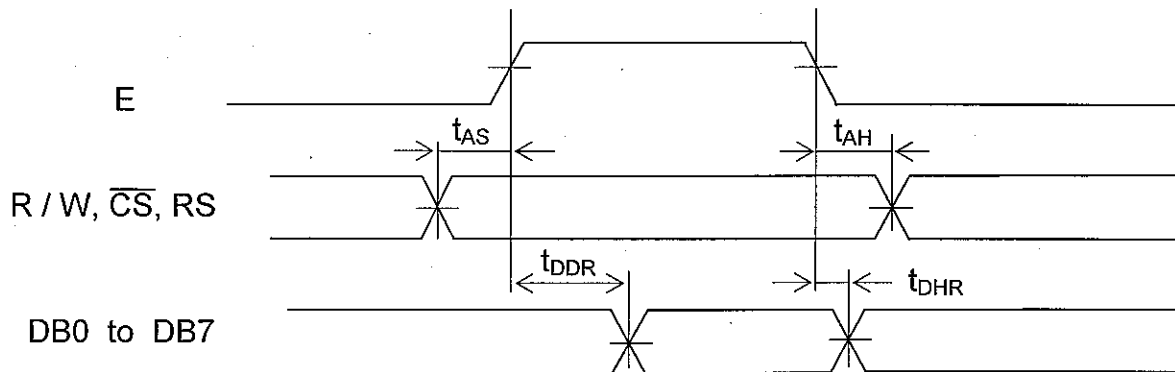

Write cycle

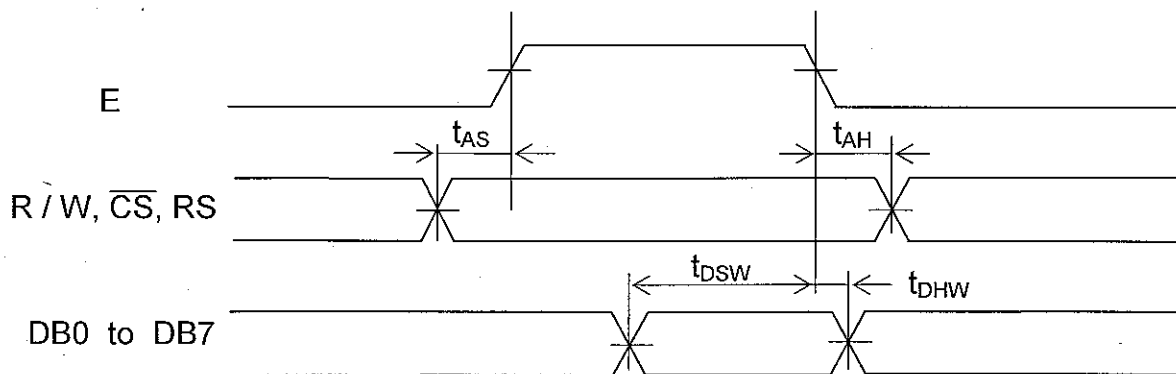

$T_a = 0$ to $+50^\circ\text{C}$, $V_{DD} = 5\text{V} \pm 5\%$, $GND = 0\text{V}$

Parameter	Symbol	Conditions	Ratings			Unit
			min	typ	max	
Address setup time	t_{AS}		90			ns
Address hold time	t_{AH}		10			ns
Data delay time (read)	t_{DDR}	$C_L = 50 \text{ pF}$			140	ns
Data hold time (read)	t_{DHR}		10			ns
Data setup time (write)	t_{DSW}		220			ns
Data hold time (write)	t_{DHW}		20			ns

11. POWER SUPPLY FOR LCD MODULE

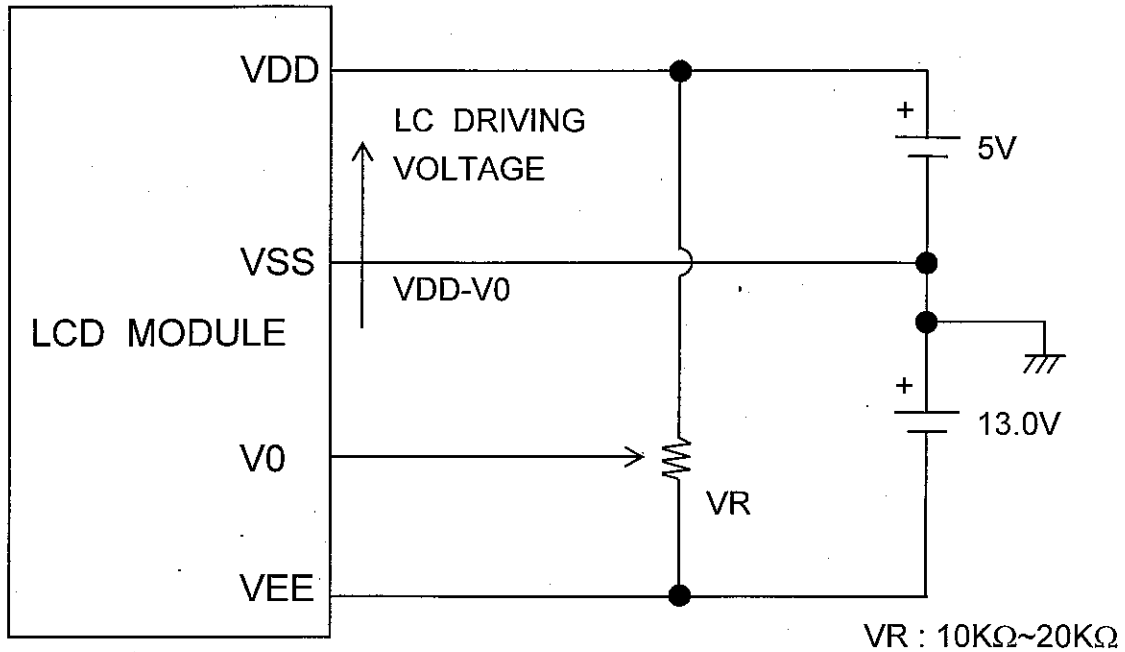

12. POWER AND INTERFACE TIMING SEQUENCE

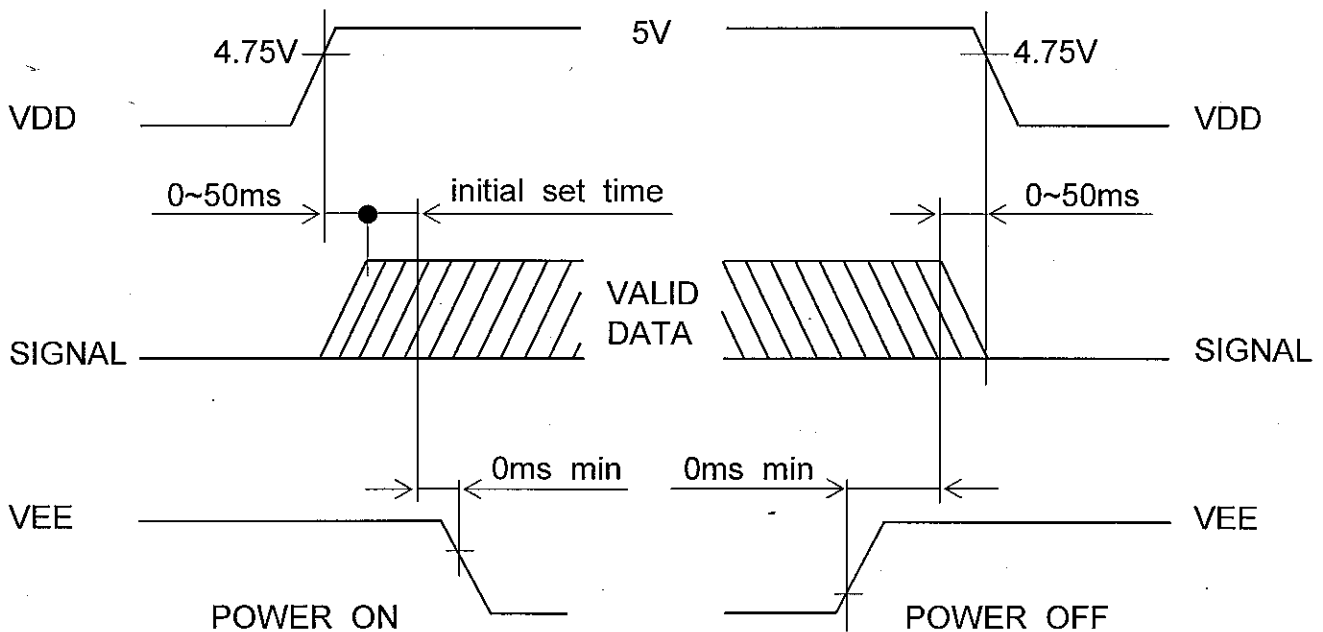

Note : Initial set time – the time is initial instructions set time of controller LC7981.

(Initial instructions : (1) Mode control.

(2) Set character pitch.

(3) Set number of characters.

(4) Set number of time division.