

mass integrated

global part distribution • product lifecycle partner
excess inventory management • value-ad service provider



Data sheet provided by Mass Integrated

massintegrated.com • displayalliance.com

Please call +1.978.465.6190
Email: sales@massintegrated.com



ISO 9001: 2008

Mass Integrated complies with all DMCA takedown notices. Please send a formal DMCA Takedown Notice to Mass Integrated Systems, Inc. • 18 Henry Graf Jr. Road, Unit 1 • Newburyport, MA 01950.



Product Description: T260XW02 TFT-LCD PANEL with RoHS Guarantee

AUO Model Name: T260XW02 VS

Customer Part No/Project Name:

Customer Signature	Date	AUO	Date
		Approved By: PM Director/ Frank Hsu Frank Hsu. 11/11	
		Reviewed By: RD Director/ Hong Hong Jye Hong Hong Jye 11/10 2008 Reviewed By: Project Leader/ Polo Shen Polo Shen 11/3, 2008	
		Prepared By: PM/ Alvin Chung Alvin Chung 11/3, 2008	



Document Version: 0.0

Date: 2008/10/31

Product Specifications

**26.0" WXGA Color TFT-LCD Module
Model Name: T260XW02 VS**

**() Preliminary Specifications
(*) Final Specifications**



Contents

No	ITEM
	COVER
	CONTENTS
	RECORD OF REVISIONS
1	GENERAL DESCRIPTION
2	ABSOLUTION MAXIMUM RATINGS
3	ELECTRICAL SPECIFICATIONS
3-1	ELECTRICAL CHARACTERISTICS
3-2	INTERFACE CONNECTIONS
3-3	SIGNAL TIMING SPECIFICATIONS
3-4	SIGNAL TIMING WAVEFORMS
3-5	COLOR INPUT DATA REFERENCE
3-6	POWER SEQUENCE for LCD
3-7	POWER SEQUENCE for INVERTER
4	OPTICAL SPECIFICATIONS
5	MECHANICAL CHARACTERISTICS
5-1	FRONT VIEW
5-2	REAR VIEW
6	RELIABILITY
7	INTERNATIONAL STANDARDS
7-1	SAFETY
7-2	EMC
7-3	GREEN
8	PACKING
9	PRECAUTIONS



Record of Revision

Version	Date	No	Old Description	New Description	Remark
0.0	2008/10/31				First release



1. General Description

This specification applies to the 26.0 inch Color TFT-LCD Module T260XW02 VS. This LCD module has a TFT active matrix type liquid crystal panel 1366x768 pixels, and diagonal size of 26.0 inch. This module supports 1366x768 XGA-WIDE mode (Non-interlace).

Each pixel is divided into Red, Green and Blue sub-pixels or dots which are arranged in vertical stripes. Gray scale or the brightness of the sub-pixel color is determined with a 8-bit gray scale signal for each dot.

The T260XW02 VS has been designed to apply the 8-bit 1 channel LVDS interface method. It is intended to support displays where high brightness, wide viewing angle, high color saturation, and high color depth are very important. The T260XW02 VS model is RoHS verified which can be distinguished on panel label.

* General Information

Items	Specification	Unit	Note
Active Screen Size	26.0	inches	
Display Area	575.769 (H) x 323.712(V)	mm	
Outline Dimension	626.0 (H) x 373.0 (V) x 46.4(D)	mm	
Driver Element	a-Si TFT active matrix		
Display Colors	16.7M	Colors	
Number of Pixels	1366 x 768	Pixel	
Pixel Pitch	0.4215	mm	
Pixel Arrangement	RGB vertical stripe		
Display Mode	Normally Black		
Surface Treatment	AG, Haze=11%, 3H		



2. Absolute Maximum Ratings

The following are maximum values which, if exceeded, may cause faulty operation or damage to the unit.

Item	Symbol	Min	Max	Unit	Conditions
Logic/LCD Drive Voltage	V_{CC}	-0.3	13.2	[Volt]	Note 1
Input Voltage of Signal	V_{in}	-0.3	3.6	[Volt]	Note 1
BLU Input Voltage	VDDDB	-0.3	27.0	[Volt]	Note 1
BLU Brightness Control Voltage	VDIM	-0.3	6.0	[Volt]	Note 1
Operating Temperature	TOP	0	+50	[°C]	Note 2
Operating Humidity	HOP	10	90	[%RH]	Note 2
Storage Temperature	TST	-20	+60	[°C]	Note 2
Storage Humidity	HST	10	90	[%RH]	Note 2
Panel Surface Temperature	PST		65	[°C]	Note 3

Note 1: Duration = 1 sec

Note 2: Maximum Wet-Bulb should be 39°C and No condensation.

The relative humidity must not exceed 90% non-condensing at temperatures of 40°C or less. At temperatures greater than 40°C, the wet bulb temperature must not exceed 39°C.

Note 3: Surface temperature is measured at 50°C Dry condition

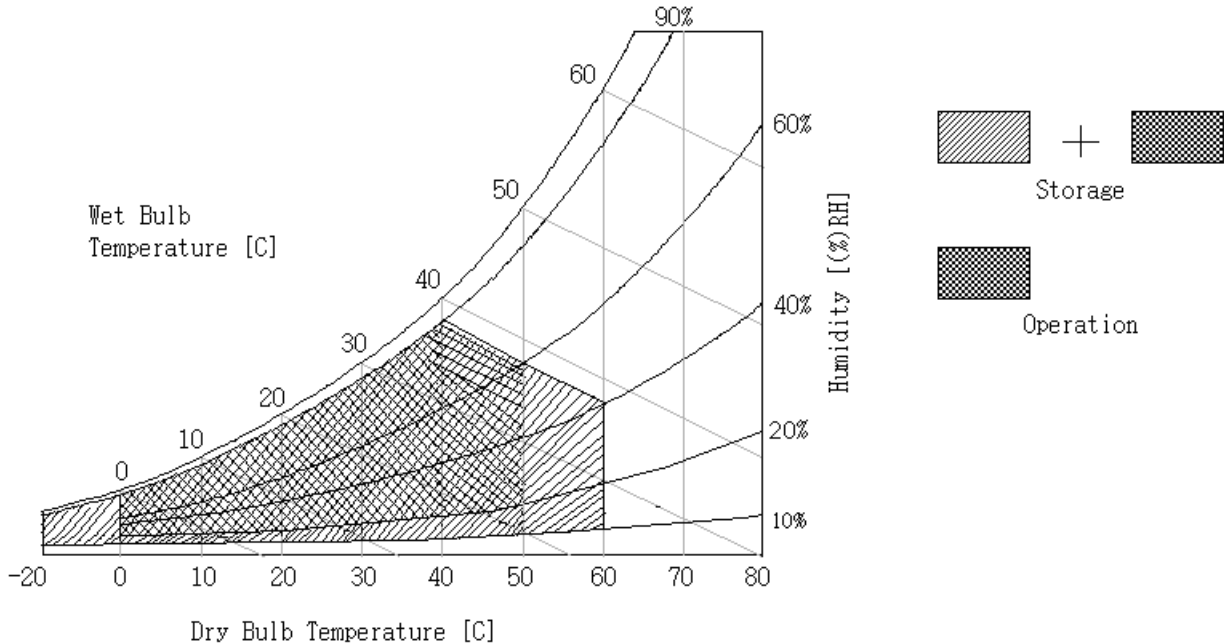

3. Electrical Specification

The T260XW02 VS requires two power inputs. One is employed to power the LCD electronics and to drive the TFT array and liquid crystal. The second input power for the BLU is to power inverter.

3-1 Electrical Characteristics

Parameter	Symbol	Values			Unit	Notes	
		Min	Typ	Max			
LCD:							
Power Supply Input Voltage	Vcc	10.8	12	13.2	Vdc	1	
Power Supply Input Current	Icc	-	0.35	0.43	A	2	
Power Consumption	Pc	-	4.2	5.16	Watt	2	
Inrush Current	I _{RUSH}	-	-	3.0	A _{peak}	3	
LVDS Interface	Differential Input High Threshold Voltage	VTH			+100	mV	4
	Differential Input Low Threshold Voltage	VTL	-100			mV	4
	Common Input Voltage	VCIM	1.10	1.25	1.40	V	4
CMOS Interface	Input High Threshold Voltage	VIH (High)	2.4		3.3	Vdc	
	Input Low Threshold Voltage	VIL (Low)	0		0.7	Vdc	
Life Time		50,000	60,000		Hours	6,7	

Note :

1. The ripple voltage should be controlled under 10% of V_{CC}
2. V_{CC}=12.0V, $f_v = 60\text{Hz}$, $f_{\text{CLK}}=81.5\text{Mhz}$, 25°C, Test Pattern : White Pattern
3. Measurement condition :

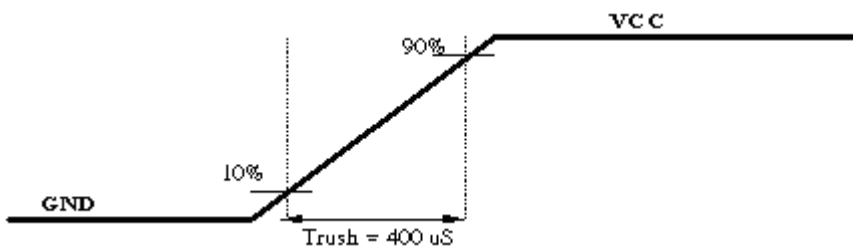

4. $V_{CIM} = 1.2V$

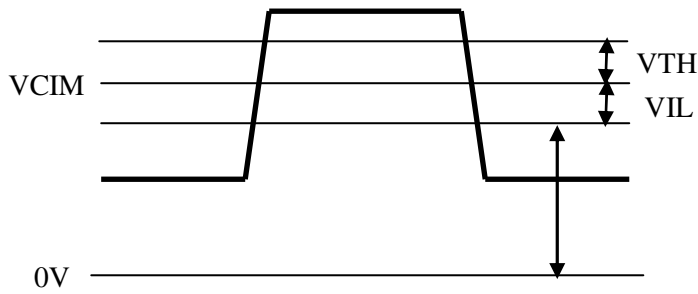

5. The performance of the Lamp in LCD panel, for example life time or brightness, is extremely influenced by the characteristics of LIPS board. All the parameters should be carefully designed as not to produce too much leakage current from high-voltage output. While you design or order the LIPS board, please make sure unwanted lighting caused by the mismatch of the lamp and the LIPS board (no lighting, flicker, etc) never occurs. After confirmation, the LCD panel should be operated in the same condition as installed in your instrument.
6. The relative humidity must not exceed 80% non-condensing at temperatures of 40°C or less. At temperatures greater than 40°C, the wet bulb temperature must not exceed 39°C. When operate at low temperatures, the brightness of CCFL will drop and the life time of CCFL will be reduced.
7. Specified values are for a single lamp only which is aligned horizontally. The lifetime is defined as the time which luminance of the lamp is 50% compared to its original value.
[Operating condition: Continuous operating at $T_a = 25 \pm 2^\circ C$]



3-2 Interface Connections

LCD connector (CN1): P-TWO 196161-30041-3 (FFC connector)

Pin No	Symbol	Description	Default
1	AGING	No Connect (AUO Aging Only)	
2	SLC	EEPROM Serial Clock	
3	SDA	EEPROM Serial Data	
4	GND	Ground	
5	R_0 -	LVDS Channel, Signal 0 -	
6	R_0+	LVDS Channel, Signal 0+	
7	GND	Ground	
8	R_1 -	LVDS Channel, Signal 1 -	
9	R_1+	LVDS Channel, Signal 1+	
10	GND	Ground	
11	R_2 -	LVDS Channel, Signal 2 -	
12	R_2+	LVDS Channel, Signal 2+	
13	GND	Ground	
14	R_CLK -	LVDS Channel, Signal Clock -	
15	R_CLK+	LVDS Channel, Signal Clock+	
16	GND	Ground	
17	R_3 -	LVDS Channel, Signal 3 -	
18	R_3+	LVDS Channel, Signal 3+	
19	GND	Ground	
20	NC	No Connect (AUO Internal Use Only)	
21	LVDS_SEL	Open/High(3.3V) for NS; Low(Gnd) for JEIDA	Default: NS
22	WP	High(3.3V) for Writable, Low(GND) for Protection	Default: Protection
23	GND	Ground	
24	GND	Ground	
25	GND	Ground	
26	VDD	Operating Voltage Supply, +12V DC Regulated	
27	VDD	Operating Voltage Supply, +12V DC Regulated	
28	VDD	Operating Voltage Supply, +12V DC Regulated	
29	VDD	Operating Voltage Supply, +12V DC Regulated	
30	VDD	Operating Voltage Supply, +12V DC Regulated	

Note:

1. All GND (ground) pins should be connected together and should also be connected to the LCD's metal frame.
2. All Vcc (power input) pins should be connected together.



LVDS Option = L (GND) → JEIDA Format

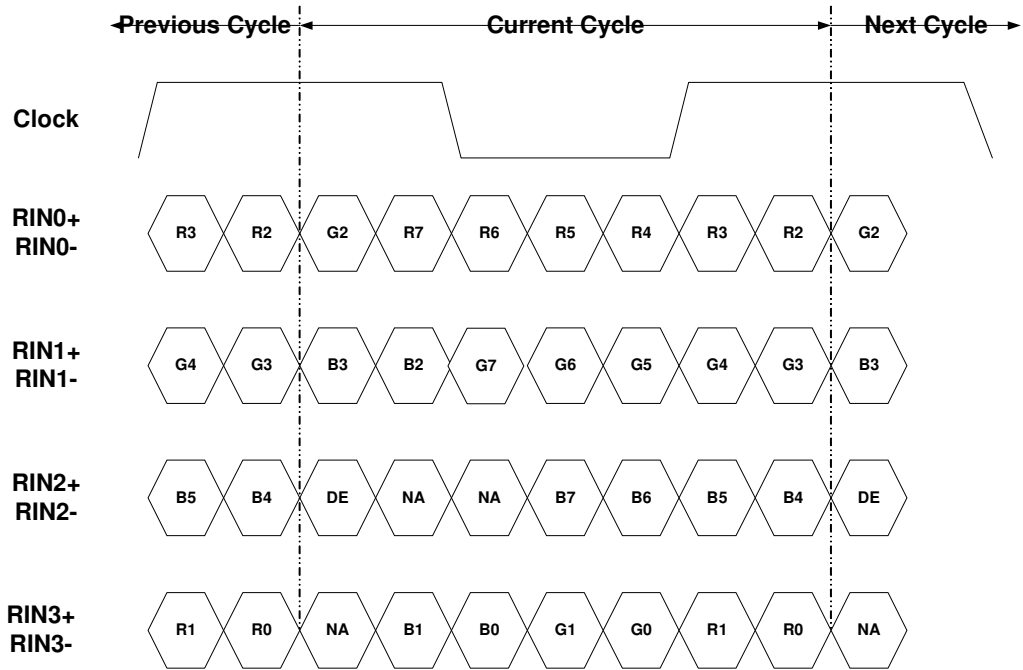

LVDS Option = H (3.3V) or OPEN → NS Format

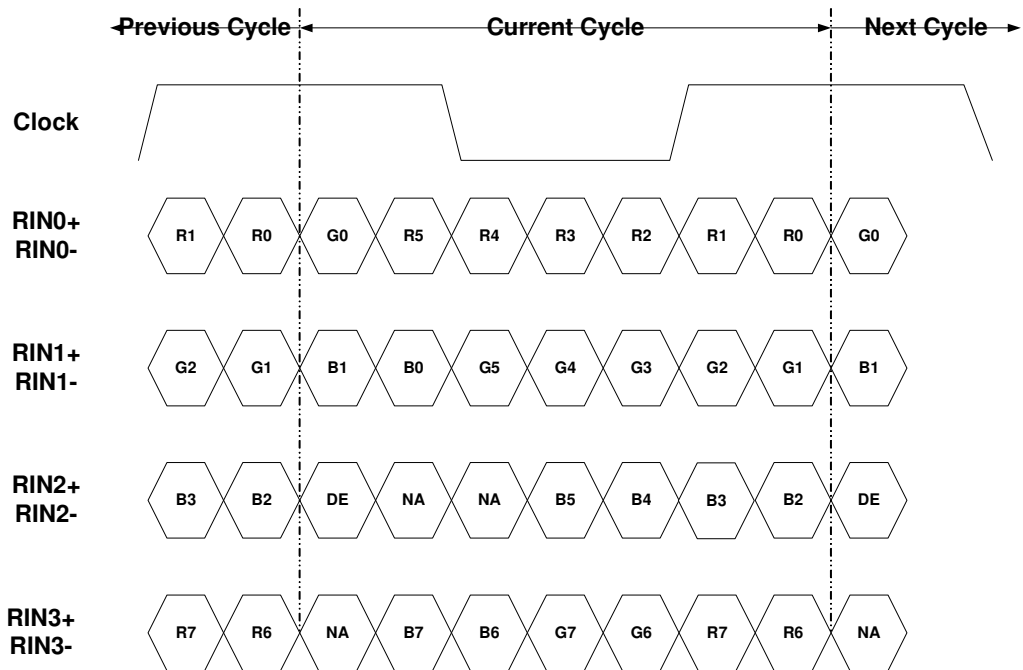



3-3 Signal Timing Specifications

This is the signal timing required at the input of the User connector. All of the interface signal timing should be satisfied with the following specifications for its proper operation.

* Timing Table

DE only Mode
Vertical Frequency

Signal	Item	Symbol	Min	Type	Max	Unit
Vertical Section	Period	Tv	776	810	1015	Th
	Active	Tdisp (v)	768			Th
	Blanking	Tblk (v)	8	42	247	Th
Horizontal Section	Period	Th	1414	1648	2000	Tclk
	Active	Tdisp (h)	1366			Tclk
	Blanking	Tblk (h)	48	282	634	Tclk
LVDS Clock	Frequency	1/Tclk	50	80	86	MHz
Vertical Frequency	Frequency	Freq	47	60	63	Hz
Horizontal Frequency	Frequency	Freq	43	48	53	KHz

Notes:

- 1) Display position is specific by the rise of DE signal only.
Horizontal display position is specified by the rising edge of 1st DCLK after the rise of 1st DE, is displayed on the left edge of the screen.
Vertical display position is specified by the rise of DE after a "Low" level period equivalent to eight times of horizontal period. The 1st data corresponding to one horizontal line after the rise the of 1st DE is displayed at the top line of screen.
- 2) If a period of DE "High" is less than 1366 DCLK or less than 768 lines, the rest of the screen displays black.
- 3) The display position does not fit to the screen if a period of DE "High" and the effective data period do not synchronize with each other.



3-4 Signal Timing Waveforms

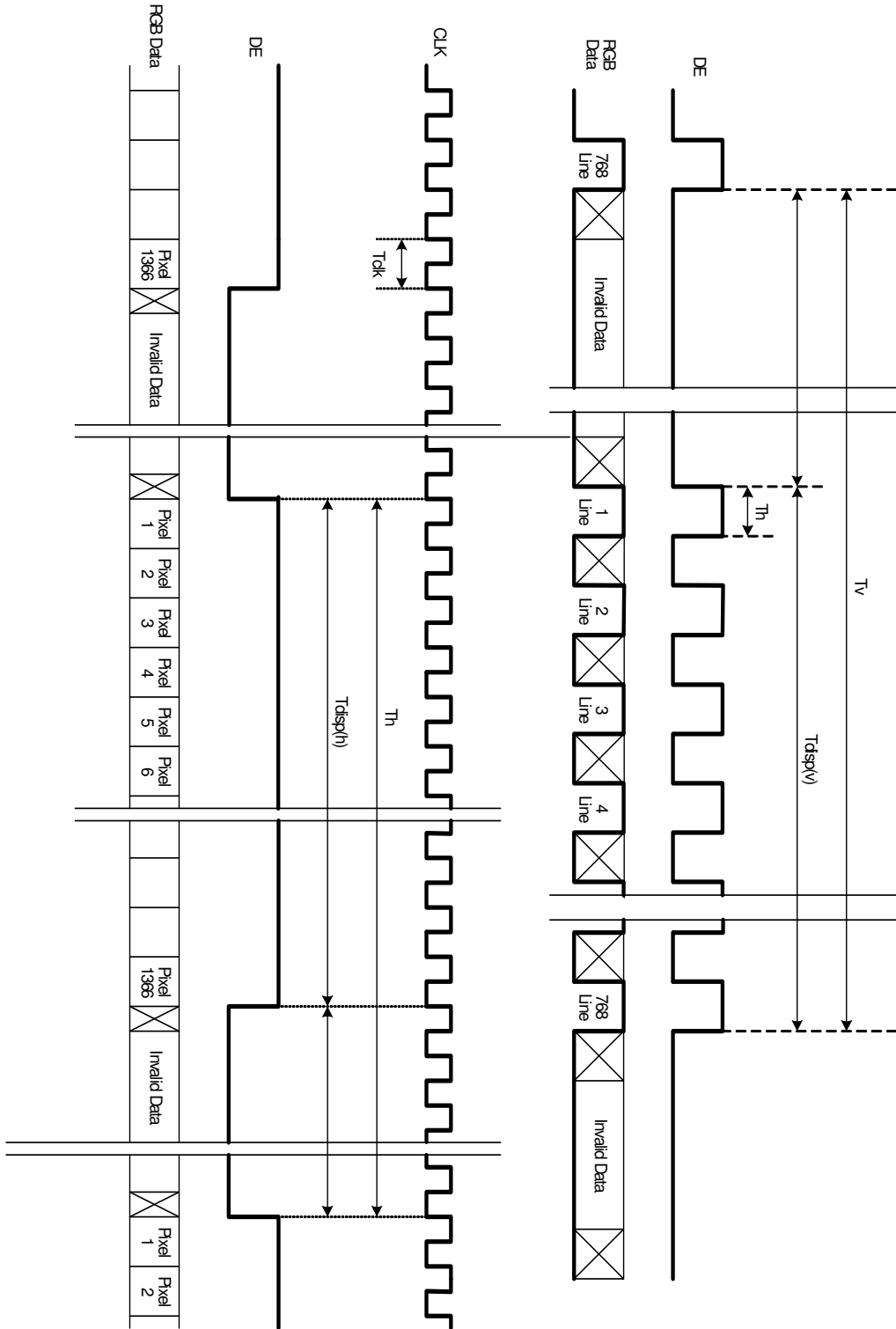



3-5 Color Input Data Reference

The brightness of each primary color (red, green and blue) is based on the 8 bit gray scale data input for the color; the higher the binary input, the brighter the color. The table below provides a reference for color versus data input.

COLOR DATA REFERENCE

Color		Input Color Data																							
		RED								GREEN								BLUE							
		MSB				LSB				MSB				LSB				MSB				LSB			
		R7	R6	R5	R4	R3	R2	R1	R0	G7	G6	G5	G4	G3	G2	G1	G0	B7	B6	B5	B4	B3	B2	B1	B0
Basic Color	Black	0	0	0	0	0	0	0	0	0	0	0	0	0	0	0	0	0	0	0	0	0	0	0	0
	Red(255)	1	1	1	1	1	1	1	1	0	0	0	0	0	0	0	0	0	0	0	0	0	0	0	0
	Green(255)	0	0	0	0	0	0	0	0	1	1	1	1	1	1	1	1	0	0	0	0	0	0	0	0
	Blue(255)	0	0	0	0	0	0	0	0	0	0	0	0	0	0	0	0	1	1	1	1	1	1	1	1
	Cyan	0	0	0	0	0	0	0	0	1	1	1	1	1	1	1	1	1	1	1	1	1	1	1	1
	Magenta	1	1	1	1	1	1	1	1	0	0	0	0	0	0	0	0	1	1	1	1	1	1	1	1
	Yellow	1	1	1	1	1	1	1	1	1	1	1	1	1	1	1	1	0	0	0	0	0	0	0	0
	White	1	1	1	1	1	1	1	1	1	1	1	1	1	1	1	1	1	1	1	1	1	1	1	1
RED	RED(000)	0	0	0	0	0	0	0	0	0	0	0	0	0	0	0	0	0	0	0	0	0	0	0	0
	RED(001)	0	0	0	0	0	0	0	1	0	0	0	0	0	0	0	0	0	0	0	0	0	0	0	0

	RED(254)	1	1	1	1	1	1	1	0	0	0	0	0	0	0	0	0	0	0	0	0	0	0	0	0
	RED(255)	1	1	1	1	1	1	1	1	0	0	0	0	0	0	0	0	0	0	0	0	0	0	0	0
GREEN	GREEN(000)	0	0	0	0	0	0	0	0	0	0	0	0	0	0	0	0	0	0	0	0	0	0	0	0
	GREEN(001)	0	0	0	0	0	0	0	0	0	0	0	0	0	0	0	1	0	0	0	0	0	0	0	0

	GREEN(254)	0	0	0	0	0	0	0	0	1	1	1	1	1	1	1	0	0	0	0	0	0	0	0	0
	GREEN(255)	0	0	0	0	0	0	0	0	1	1	1	1	1	1	1	1	0	0	0	0	0	0	0	0
BLUE	BLUE(000)	0	0	0	0	0	0	0	0	0	0	0	0	0	0	0	0	0	0	0	0	0	0	0	0
	BLUE(001)	0	0	0	0	0	0	0	0	0	0	0	0	0	0	0	0	0	0	0	0	0	0	0	1

	BLUE(254)	0	0	0	0	0	0	0	0	0	0	0	0	0	0	0	0	1	1	1	1	1	1	1	0
	BLUE(255)	0	0	0	0	0	0	0	0	0	0	0	0	0	0	0	0	1	1	1	1	1	1	1	1

3-6 Power Sequence for LCD

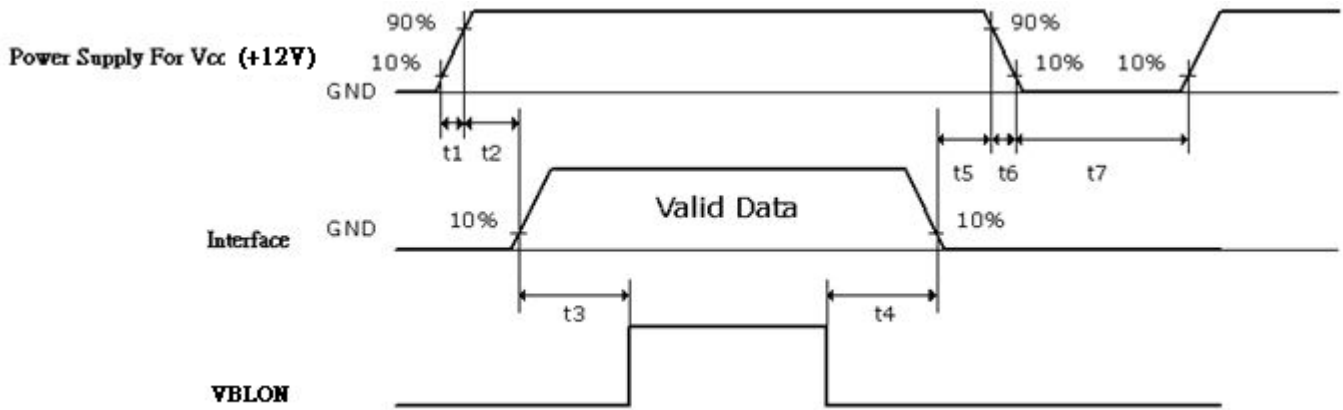

Parameter	Values			Units
	Min.	Typ.	Max.	
t1	0.4	-	30	ms
t2	0.1	-	50	ms
t3	200	-	-	ms
t4	10	-	-	ms
t5	0.1	-	50	ms
t6	-	-	300	ms
t7	500	-	-	ms

Note:

The timing controller will not be damaged in case of TV set AC input power suddenly shut down.

Once power reset, it should follow power sequence as spec. definition.

- (1) Apply the lamp voltage within the LCD operation range. When the back-light turns on before the LCD operation or the LCD turns off before the back-light turns off, the display may momentarily become abnormal screen.



3-7 Backlight Power Specification for LCD Module

3.7.1 Electrical specification

Description		Min	Typ	Max	Unit	Condition/Note		
1	Operating Voltage	Vo	1152	1280	1408	Vrms	1. Dimming range is set 100% 2. Base on lamp specification, for each lamp need to be applied at least minimum operating voltage to ensure each lamp can be normally worked!	
2	Operating Current	Io	11	11.5	12	mArms	1. Dimming range is set 100% 2. Base on lamp specification, for each lamp need to be applied at least minimum operating current to ensure each lamp can be normally worked!	
3	BL Total Power Dissipation	PBL	61.5	65	68.5	Watt	1. Dimming range is set 100%. 2. In order to get typical light out, the backlight need to be applied typical power. 3. Input power of JIG BD is about <u>65 W (typ)</u> by AUO measure!	
4	Striking Voltage	At 0°C	Vstrike	2150	2450	-	Vrms	1. Base on lamp specification, to ensure each lamp can be normally ignited, need to apply at least minimum striking voltage to each lamp
		At 25°C		2250	2550	-		
5	Striking Time	Ts	1000	-	1500	msec	1. To ensure each lamp can be normally ignited, each lamp need to be applied at least minimum striking voltage during minimum striking time.	
6	Operating Frequency	fo	-	63	-	KHz	1. Operating frequency is set by customer. 2. Need to double confirm display quality.(*)	
7	PWM Operating Frequency	F_PWM	140	180	240	Hz	1. PWM frequency is set by customer. 2. Need to double confirm display quality.(*)	
8	PWM Dimming Duty Ratio	D_PWM	20	-	100	%	Note 1. Dimming range Note 2. Note 3. Duty ratio definition.	
9	Lamp Type	U type						
10	Number of Lamps	4			pcs			

(Ta=25±5°C , Turn on for 45minutes)

(*) The operating frequency of lamp may produce interference with horizontal frequency from display, and may cause line noise on the display. In order to avoid interference, the operating frequency should be separated from horizontal frequency.



Note 1:
Dimming range



PWM Dimming : include Internal and External PWM Dimming

Note 2:
When PWM dimming ratio is operated less than recommend value, feedback signal and all protection functions should be confirmed for LIPS design. Picture performance and quality should also be confirmed by customers.

Note 3:
Duty ratio definition.

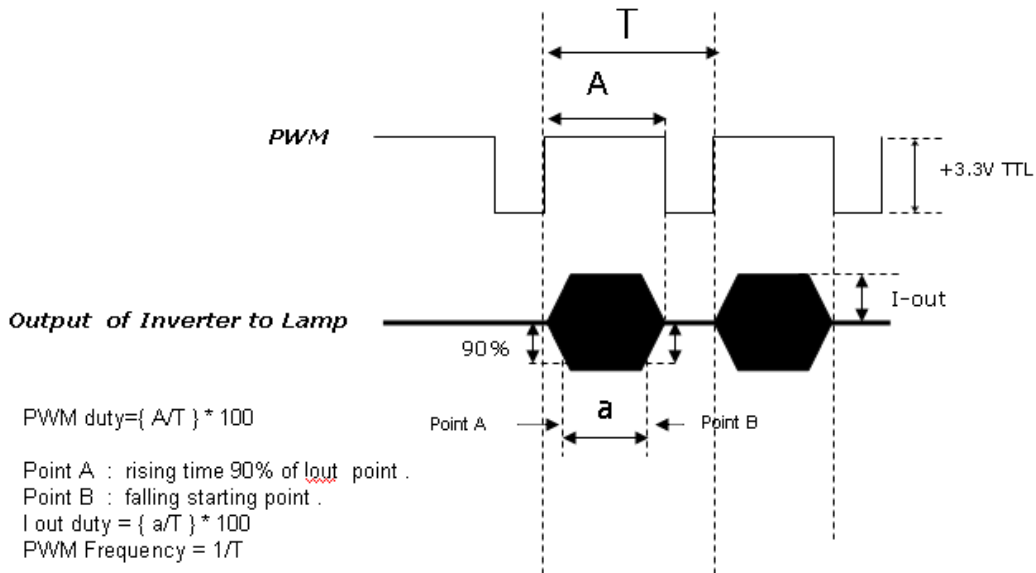

2. Lamp specification

	Description	Min	Typ	Max	Unit	Note	
1	Lamp voltage	V_{lamp}	1152	1280	1408	Vrms	At $I_{lamp}=11.5mA$
2	Lamp current	I_{lamp}	-	11.5	-	mArms	
3	Lamp frequency	f_{lamp}	40	-	80	kHz	
4	Striking voltage	At 25°C	-	-	2150	Vrms	
		At 0°C	-	-	2250	Vrms	
5	Delayed discharge time	T_{delay}	-	-	1000	msec	
6	Life time	50K	-	-	-	hr	
7	Unsymmetrical ratio	-	-	10%	-	Note 1.	
8	Crest factor (C.F)	$\sqrt{2} - 10\%$	$\sqrt{2}$	$\sqrt{2} + 10\%$	-		

The above characteristics are measured under the conditions:
Ambient temperature: 25±2°C, Relative Humidity: 65±20%RH.

Note 1:

Please light on the lamp with symmetrical voltage and current waveform (unsymmetrical ratio is less than 10%, crest factor within $\sqrt{2} \pm 10\%$). The inverter output waveform should be better similar to the ideal sine wave.

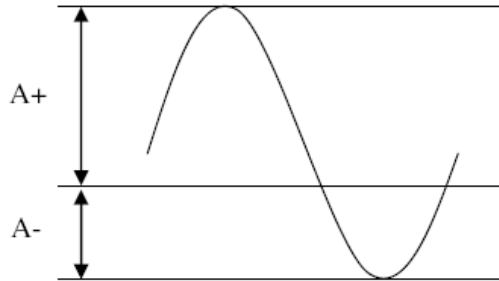

$$\text{Unsymmetrical ratio} = |(A+) - (A-)| / \text{Arms} * 100\%$$

$$\text{Crest factor} = (A+) / \text{Arms} \text{ or } (A-) / \text{Arms}$$

A+ : Plus of peak value

A- : Minus of peak value

Arms : Root mean square value



3.7.2 Input Interface for LIPS board (Socket Type) - CN1: EL7H001ZZ2 (Manufactured by JAE)

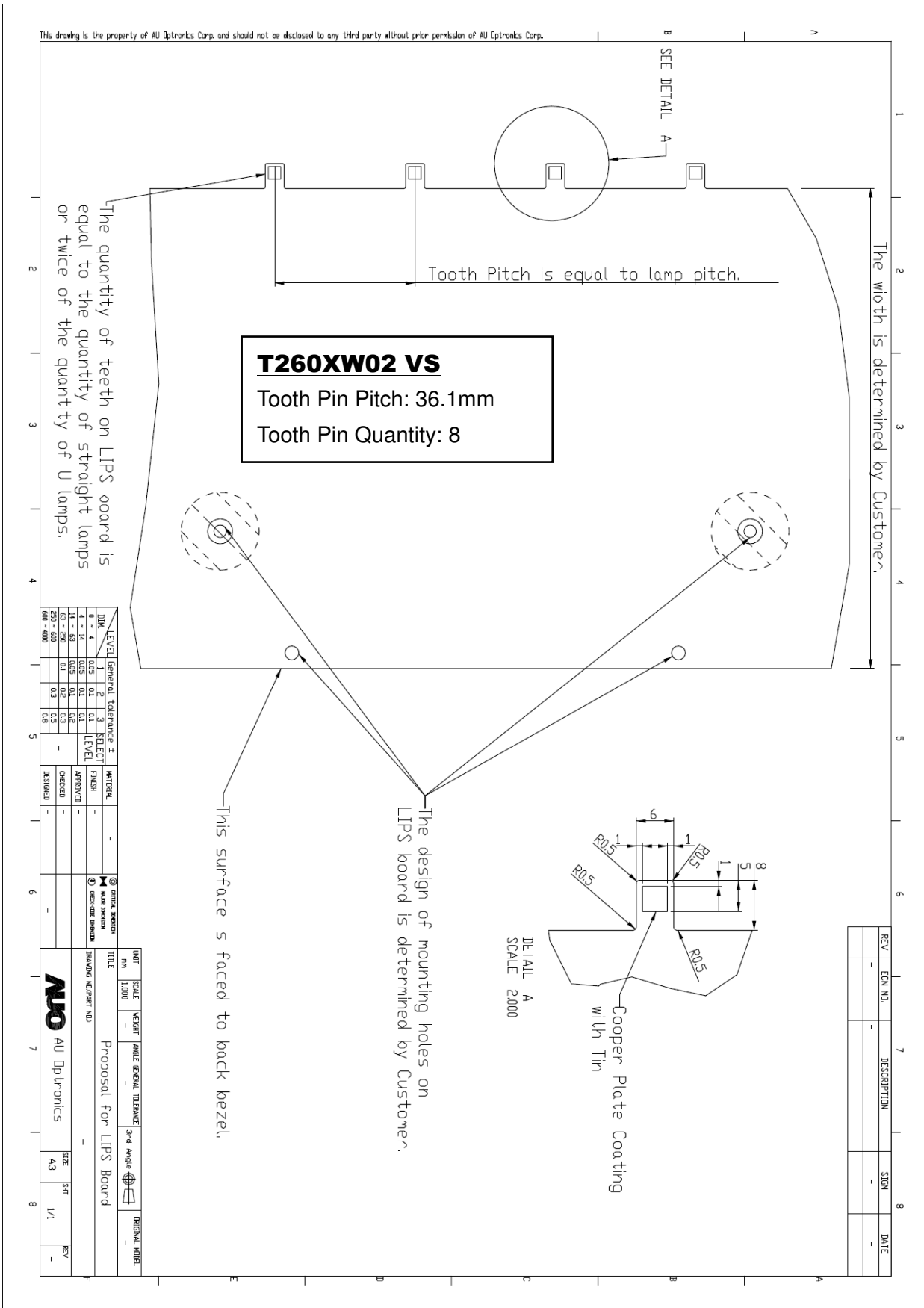

4. Optical Specification

Optical characteristics are determined after the unit has been 'ON' and stable for approximately 45 minutes in a dark environment at 25°C. The values specified are at an approximate distance 50cm from the LCD surface at a viewing angle of Φ and θ equal to 0°. Signal generator used for measurement is "Chroma 2913" and signal setting follows the typical value shown in page 13 with vertical frequency range A (fv=60Hz). Meanwhile, dimmer is 3.3(V) for its maximum setting.

Fig.1 1 presents additional information concerning the measurement equipment and method.

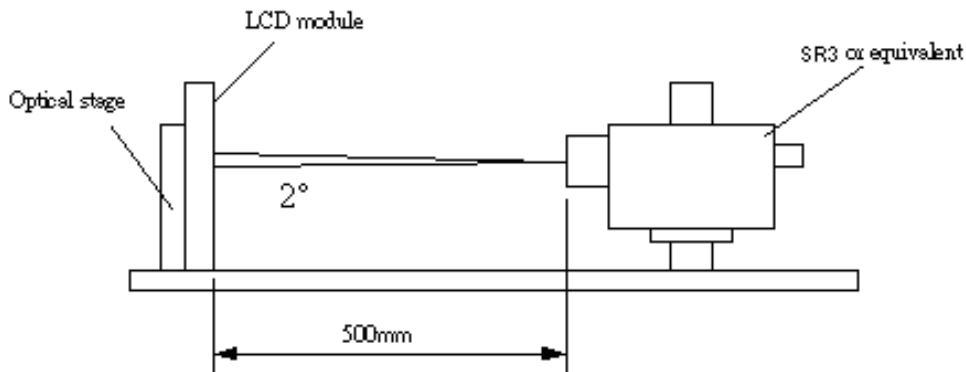

Parameter	Symbol	Values			Units	Notes
		Min.	Typ.	Max.		
Contrast Ratio	CR	2400	3000			1
Surface Luminance, white	LWH	360	450		cd/m ²	2
Luminance Variation	δ_{WHITE} 9 p			1.3		3
Response Time (G to G)	T _y		6.5		ms	4
Color Gamut	NTSC		72		%	
Color Coordinates						
	RED	R _x	Typ.-0.03	0.64	Typ.+0.03	
		R _y		0.33		
	GREEN	G _x		0.28		
		G _y		0.59		
	BLUE	B _x		0.15		
		B _y		0.05		
	WHITE	W _x		0.28		
		W _y		0.29		
Viewing Angle						
	x axis, right($\phi=0^\circ$)	θ_r		89		5
	x axis, left($\phi=180^\circ$)	θ_l		89	Degree	
	y axis, up($\phi=90^\circ$)	θ_u		89	Degree	
	y axis, down ($\phi=0^\circ$)	θ_d		89	Degree	

Note:

1. Contrast Ratio (CR) is defined mathematically as:

$$\text{Contrast Ratio} = \frac{\text{Surface Luminance of } L_{\text{on5}}}{\text{Surface Luminance of } L_{\text{off5}}}$$

2. Surface luminance is luminance value at point 1 across the LCD surface 50cm from the surface with all pixels displaying white. From more information see FIG 2. When $V_{\text{DDB}} = 24\text{V}$, $I_{\text{DDB}} = 1.67\text{A}$. $L_{\text{WH}} = L_{\text{on1}}$

Where L_{on1} is the luminance with all pixels displaying white at center 5 location.

3. The variation in surface luminance, δ_{WHITE} is defined (center of Screen) as:

$$\delta_{\text{WHITE(9P)}} = \frac{\text{Maximum}(L_{\text{on1}}, L_{\text{on2}}, \dots, L_{\text{on9}})}{\text{Minimum}(L_{\text{on1}}, L_{\text{on2}}, \dots, L_{\text{on9}})}$$

4. Response time T_{γ} is the average time required for display transition by switching the input signal for five luminance ratio (0%,25%,50%,75%,100% brightness matrix) and is based on $f_v = 60\text{Hz}$ to optimize.

	0%	25%	50%	75%	100%
0%		t:0%-25%	t:0%-50%	t:0%-75%	t:0%-100%
25%	t:25%-0%		t:25%-50%	t:25%-75%	t:25%-100%
50%	t:50%-0%	t:50%-25%		t:50%-75%	t:50%-100%
75%	t:75%-0%	t:75%-25%	t:75%-50%		t:50%-100%
100%	t:100%-0%	t:100%-25%	t:100%-50%	t:100%-75%	

5. Viewing angle is the angle at which the contrast ratio is greater than 10. The angles are determined for the horizontal or x axis and the vertical or y axis with respect to the z axis which is normal to the LCD surface. For more information see FIG4.

FIG. 2 Luminance

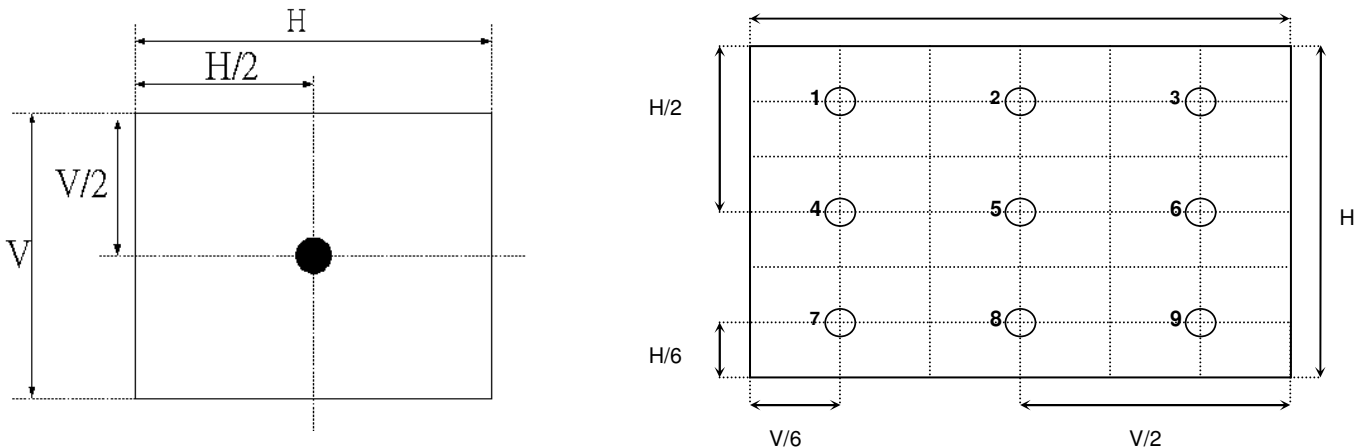

FIG.3 Response Time

The response time is defined as the following figure and shall be measured by switching the input signal for “any level of gray(bright) “ and “any level of gray(dark)”.

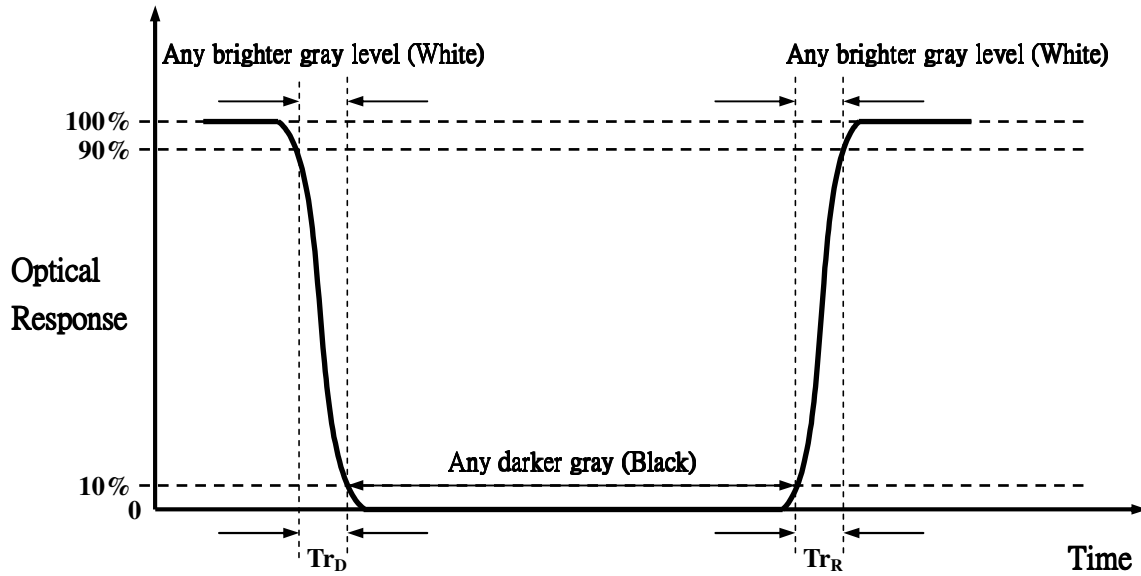
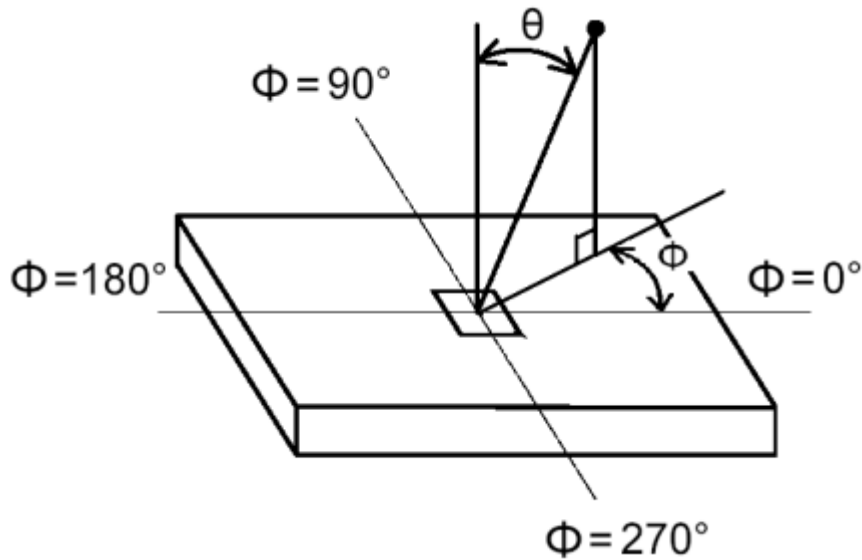

FIG.4 Viewing angle





5. Mechanical Characteristics

The contents provide general mechanical characteristics for the model T260XW02 VS. In addition the figures in the next page are detailed mechanical drawing of the LCD.

Outline Dimension	Horizontal	626.0mm
	Vertical	373.0mm
	Depth	46.4mm(w/ socket cover) 40.0mm(light box+emboss)
Bezel Area	Horizontal	580.8mm±0.5mm
	Vertical	328.8mm±0.5mm
Active Display Area	Horizontal	575.769mm
	Vertical	323.712mm
Weight	3720g (Typ.)	
Surface Treatment	AG, Haze=11%, 3H	



Reliability

Environment test condition

	Test Items	Q'ty	Conditions
1	High Temperature Storage	3	60°C 300 hrs
2	Low Temperature Storage	3	-20°C, 300 hrs
3	High Temperature Operation	3	50°C, 300 hrs
4	Low Temperature Operation	3	-5°C, 300 hrs
5	Vibration (non-operation)	3	(10 ~ 300Hz/1.5G/11min SR, XYZ 30min/axis) Vibration level : 1.5G RMS, Bandwidth : 10-300Hz Duration: X, Y, Z 30min,
6	Shock (non-operation)	3	Shock level: 50G Waveform: have sine wave, 11ms Direction: ±X,±Y, ±Z One time each direction
7	Vibration (With carton)	3	Random wave (1.5 Grms 10~200Hz) 30mins / Per each X.Y.Z axes
8	Drop (With carton)	3	Height: 457mm 1 corner, 3 edges, 6 surfaces (ASTMD4169-I)



6. International Standard

7-1 Safety



- (1) UL1950 Third Edition, Underwriters Laboratories, Inc. Jan. 28, 1995
Standard for Safety of Information Technology Equipment Including electrical Business Equipment.
- (2) CAN/CSA C22.2 No. 950-95 Third Edition, Canadian Standards Association, Jan. 28, 1995
Standard for Safety of Information Technology Equipment Including Electrical Business Equipment.
- (3) EN60950: 1992+A2: 1993+A2: 1993+C3: 1995+A4: 1997+A11: 1997
IEC 950: 1991+A1: 1992+A2: 1993+C3: 1995+A4:1996
European Committee for Electro technical Standardization (CENELEC)
EUROPEAN STANDARD for Safety of Information Technology Equipment Including Electrical Business Equipment.
- (4) EN60065

7-2 EMC

- a) ANSI C63.4 “Methods of Measurement of Radio-Noise Emissions from Low-Voltage Electrical and Electrical Equipment in the Range of 9kHz to 40GHz. “American National standards Institute(ANSI), 1992.
- b) C.I.S.P.R “Limits and Methods of Measurement of Radio Interface Characteristics of Information Technology Equipment.” International Special committee on Radio Interference.
- c) EN 55022 “Limits and Methods of Measurement of Radio Interface Characteristics of Information Technology Equipment.” European Committee for Electro technical Standardization. (CENELEC), 1998.

7-3 Green

Green Mark Description:

- a) For Pb Free products, AUO will add  for identification.
- b) For RoHS compatible products, AUO will add  for identification.

Note.

The Green Mark will be present only when the green documents have been ready by AUO Internal Green Team. (The definition of green design follows the AUO green design checklist.)



8. Packing

Label sample

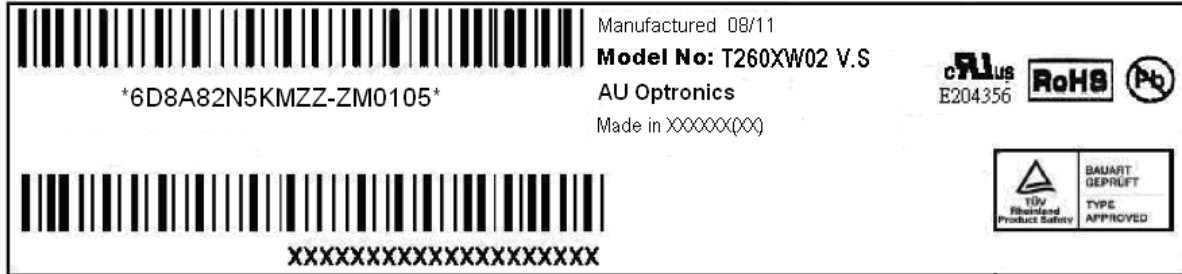

6D8A82N5KMZZ-ZM0105

6D8A82N5KMZZ: Panel serial number

ZM0: AUO internal code

Manufactured 08/11: 2008 week 11

Carton Label

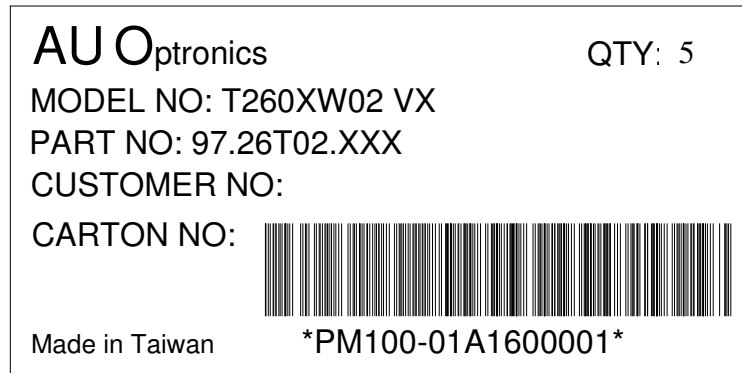

Carton Size 722(L) mm*350(W) mm*469(H) mm

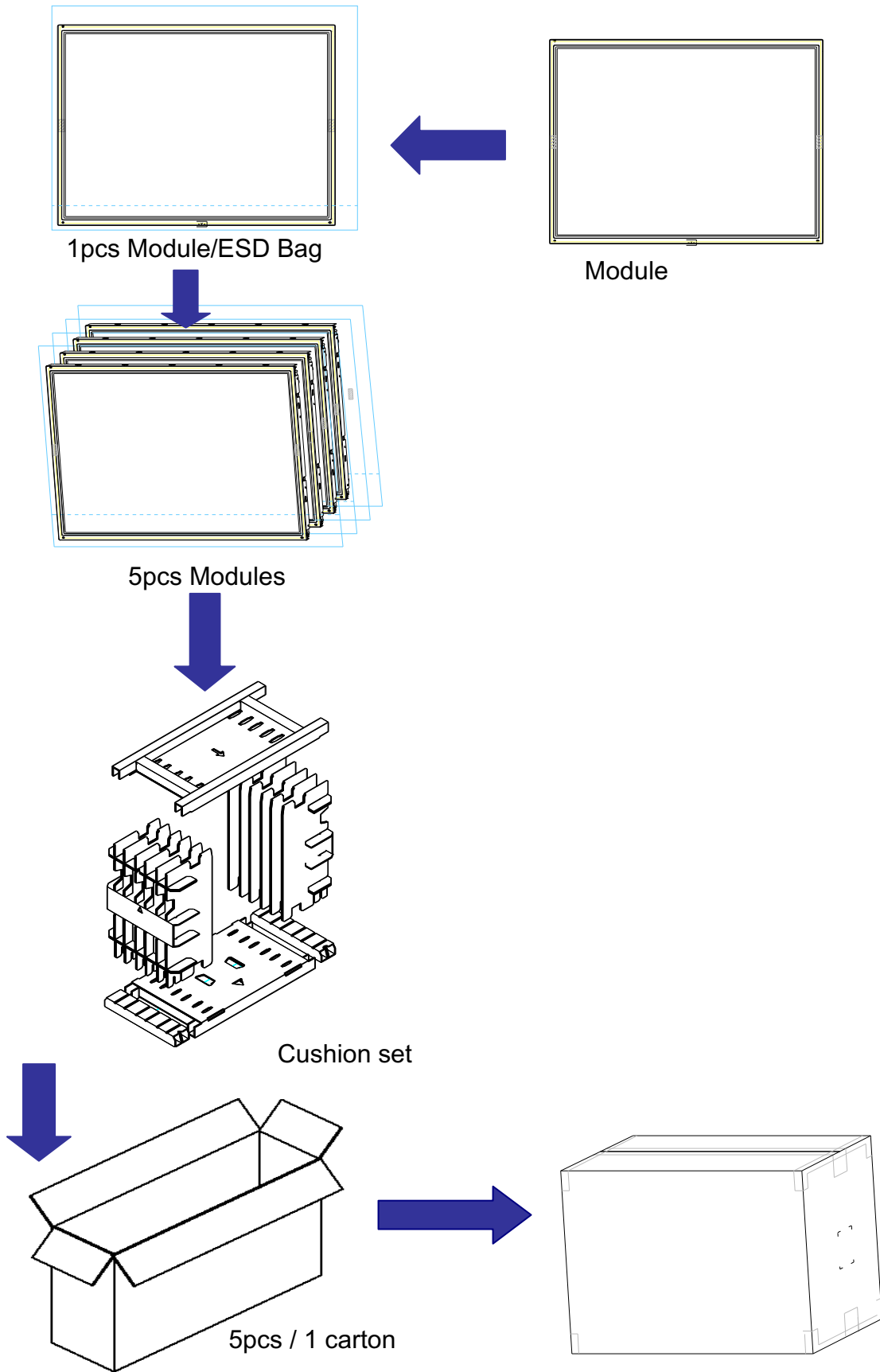



Pallet and Shipment information

	Item	Specification			Packing Remark
		Qty.	Dimension	Weight (kg)	
1	Packing BOX	5pcs/box	722(L)mm*350(W)mm*469(H)mm	25	
2	Pallet	1	1060(L)mm*740(W)mm*138(H)mm	13	
3	Boxes per Pallet	6 boxes/pallet			
4	Panels per Pallet	30pcs/pallet			
	Pallet after packing		1060(L)mm*740(W)mm*1076(H)mm	163	

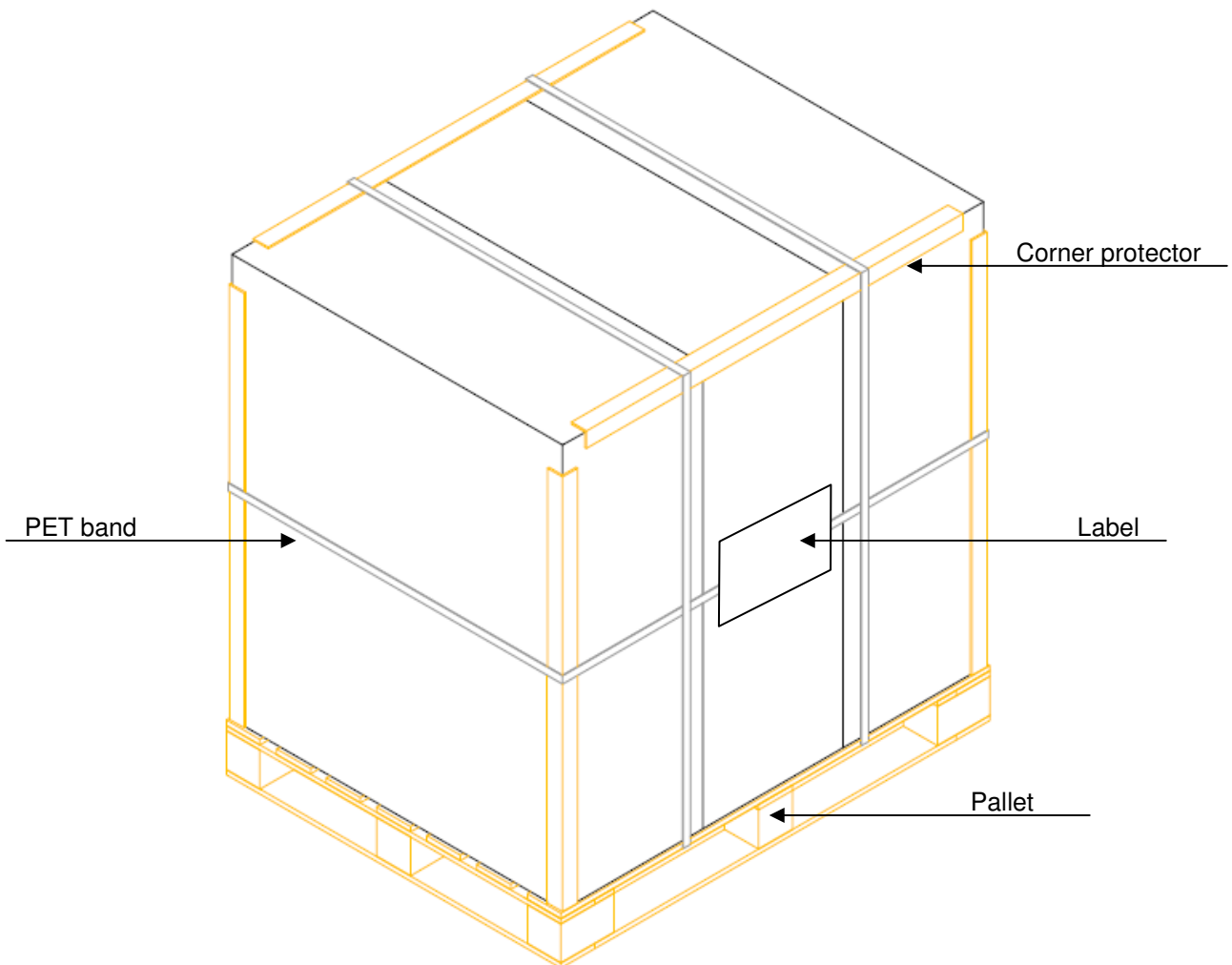



9. PRECAUTIONS

Please pay attention to the followings when you use this TFT LCD module.

9-1 MOUNTING PRECAUTIONS

- (1) You must mount a module using holes arranged in four corners or four sides.
- (2) You should consider the mounting structure so that uneven force (ex. Twisted stress) is not applied to module. And the case on which a module is mounted should have sufficient strength so that external force is not transmitted directly to the module.
- (3) Please attach the surface transparent protective plate to the surface in order to protect the polarizer. Transparent protective plate should have sufficient strength in order to resist external force.
- (4) You should adopt radiation structure to satisfy the temperature specification.
- (5) Acetic acid type and chlorine type materials for the cover case are not desirable because the former generates corrosive gas of attacking the polarizer at high temperature and the latter causes circuit break by electro-chemical reaction.
- (6) Do not touch, push or rub the exposed polarizers with glass, tweezers or anything harder than HB pencil lead. And please do not rub with dust clothes with chemical treatment. Do not touch the surface of polarizer for bare hand or greasy cloth. (Some cosmetics are detrimental to the polarizer.)
- (7) When the surface becomes dusty, please wipe gently with absorbent cotton or other soft materials like chamois soaks with petroleum benzene. Normal-hexane is recommended for cleaning the adhesives used to attach front/ rear polarizers. Do not use acetone, toluene and alcohol because they cause chemical damage to the polarizer.
- (8) Wipe off saliva or water drops as soon as possible. Their long time contact with polarizer causes deformations and color fading.
- (9) Do not open the case because inside circuits do not have sufficient strength.

9-2 OPERATING PRECAUTIONS

- (1) The device listed in the product specification sheets was designed and manufactured for TV application
- (2) The spike noise causes the mis-operation of circuits. It should be lower than following voltage: $V=\pm 200\text{mV}$ (Over and under shoot voltage)
- (3) Response time depends on the temperature. (In lower temperature, it becomes longer.)
- (4) Brightness depends on the temperature. (In lower temperature, it becomes lower.) And in lower temperature, response time (required time that brightness is stable after turned on) becomes longer.
- (5) Be careful for condensation at sudden temperature change. Condensation makes damage to polarizer or electrical contacted parts. And after fading condensation, smear or spot will occur.
- (6) When fixed patterns are displayed for a long time, remnant image is likely to occur.
- (7) Module has high frequency circuits. Sufficient suppression to the electromagnetic interference shall be done by system manufacturers. Grounding and shielding methods may



be important to minimize the interface.

9-3 ELECTROSTATIC DISCHARGE CONTROL

Since a module is composed of electronic circuits, it is not strong to electrostatic discharge. Make certain that treatment persons are connected to ground through wrist band etc. And don't touch interface pin directly.

9-4 PRECAUTIONS FOR STRONG LIGHT EXPOSURE

Strong light exposure causes degradation of polarizer and color filter.

9-5 STORAGE

When storing modules as spares for a long time, the following precautions are necessary.

- (1) Store them in a dark place. Do not expose the module to sunlight or fluorescent light. Keep the temperature between 5°C and 35°C at normal humidity.
- (2) The polarizer surface should not come in contact with any other object. It is recommended that they be stored in the container in which they were shipped.

9-6 HANDLING PRECAUTIONS FOR PROTECTION FILM

- (1) The protection film is attached to the bezel with a small masking tape. When the protection film is peeled off, static electricity is generated between the film and polarizer. This should be peeled off slowly and carefully by people who are electrically grounded and with well ion-blown equipment or in such a condition, etc.
- (2) When the module with protection film attached is stored for a long time, sometimes there remains a very small amount of glue still on the Bezel after the protection film is peeled off.
- (3) You can remove the glue easily. When the glue remains on the Bezel or its vestige is recognized, please wipe them off with absorbent cotton waste or other soft material like chamois soaked with normal-hexane.