

mass integrated

global part distribution • product lifecycle partner
excess inventory management • value-ad service provider



Data sheet provided by Mass Integrated

massintegrated.com • displayalliance.com

Please call +1.978.465.6190
Email: sales@massintegrated.com



ISO 9001: 2008

Mass Integrated complies with all DMCA takedown notices. Please send a formal DMCA Takedown Notice to Mass Integrated Systems, Inc. • 18 Henry Graf Jr. Road, Unit 1 • Newburyport, MA 01950.

MODEL NO. : TM022GBH17ISSUED DATE: 2009-7-23VERSION : Ver 1.0

- Preliminary Specification
 Final Product Specification

Customer : _____

Approved by	Notes

SHANGHAI TIANMA Confirmed :

Prepared by	Checked by	Approved by

This technical specification is subjected to change without notice

The information contained herein is the exclusive property of SHANGHAI TIANMA MICRO-ELECTRONICS Corporation, and shall not be distributed, reproduced, or disclosed in whole or in part without prior written permission of SHANGHAI TIANMA MICRO-ELECTRONICS Corporation.



Table of Contents

Coversheet.....	1
Table of Contents.....	2
Record of Revision.....	3
1 General Specifications	4
2 Input/Output Terminals	5
3 Absolute Maximum Ratings	6
4 Electrical Characteristics.....	7
5 Timing Chart.....	9
6 Optical Characteristics	15
7 Environmental / Reliability Tests.....	19
8 Mechanical Drawing.....	20
9 Packing Drawing	21
10 Precautions for Use of LCD Modules.....	22



1 General Specifications

	Feature	Spec
Display Spec.	Size	2.2 inch
	Resolution	176(RGB) x 220
	Interface	CPU 8 bits/16bits
	Color Depth	262K/65k
	Technology Type	a-Si
	Pixel Pitch (mm)	0.18X0.18
	Pixel Configuration	R.G.B. Vertical Stripe
	Display Mode	TM with Normally White
	Surface Treatment(Up Polarizer)	Clear Type(3H)
	Viewing Direction	6 o'clock
	Gray Scale Inversion Direction	12 o'clock
Mechanical Characteristics	LCM (W x H x D) (mm)	41.70x56.16x3.60
	Active Area(mm)	34.85x43.56
	With /Without TSP	With TSP
	Weight (g)	TBD
	LED Numbers	3 LEDs
Electronic	Driver IC	HX8340B

Note 1: Viewing direction for best image quality is different from TFT definition, there is a 180 degree shift.

Note 2: Requirements on Environmental Protection: RoHS

Note 3: LCM weight tolerance : +/- 5%



2 Input/Output Terminals

2.1 TFT LCD Panel

No	Symbol	I/O	Description	Comment
1	DB15	I	Data Bus	
2	DB14	I	Data Bus	
3	DB13	I	Data Bus	
4	DB12	I	Data Bus	
5	DB11	I	Data Bus	
6	DB10	I	Data Bus	
7	DB9	I	Data Bus	
8	DB8	I	Data Bus	
9	GND	P	Ground	
10	DB7	I	Data Bus	
11	DB6	I	Data Bus	
12	DB5	I	Data Bus	
13	DB4	I	Data Bus	
14	DB3	I	Data Bus	
15	DB2	I	Data Bus	
16	DB1	I	Data Bus	
17	DB0	I	Data Bus	
18	IOVCC	P	Power Supply	
19	VCI/VCC	P	Power Supply	
20	/RD	I	Read signal Read:rising edge(/WR='1')	
21	/WR	I	Write signal Write:rising edge(/RD='1')	
22	RS	I	Register select low: Index high:Data	
23	/CS	I	Chip selection Active low	
24	/RESET	I	Reset signal Active low	
25	IM0	I	Mode select low :16bit high:8bit	
26	GND	P	Ground	
27	LED_A	P	Led Power	
28	LED_K1	P	Led Power	
29	LED_K2	P	Led Power	
30	LED_K3	P	Led Power	
31	Y+	O	Touch Panel signal: Top	
32	Y-	O	Touch Panel signal: Down	
33	X+	O	Touch Panel signal: Right	
34	X-	O	Touch Panel signal: Left	
35	NC	—		
36	NC	—		

Note 1: I/O definition: I-----Input O---Output P----Power(Ground) NC---No connection



3 Absolute Maximum Ratings

3.1 Driving TFT LCD Panel

Ta = 25°C

Item	Symbol	Min.	Max.	Unit	Remark
Logic Power Supply	IOVCC	-0.3	3.6	V	
Analog Power Supply	IOVCC/VCCI	-0.3	3.6	V	
Logic Input Voltage	DB0~DB15,RS,WR,CS,RD,RESET,IM0	-0.3	IOVCC +0.5	V	
Back Light Forward Current	I _{LED}	--	25	mA	For each LED
Operating Temperature	T _{OPR}	-20	70	°C	
Storage Temperature	T _{STG}	-30	80	°C	



4 Electrical Characteristics

4.1 Driving TFT LCD Panel

GND=0V, Ta=25°C

Item	Symbol	Min.	Typ.	Max.	Unit	Remark
Logic Power Supply	IOVCC	2.5	2.8	3.3	V	
Analog Power Supply	VCC/VCCI	2.5	2.8	3.3	V	
Input Signal Voltage	Low Level	V _{IL}	GND	--	0.3xIOVCC	DB0~DB15,RS,WR,CS, RD,RESET,IM0
	High Level	V _{IH}	0.7xIOVCC	--	IOVCC	
(Panel+ LSI) Power Consumption	Black Mode	--	--	--	mA	
	8 color Mode	--	--	--	mA	
	Sleeping Mode	--	--	--	uA	

4.2 Driving Backlight

Ta=25°C

Item	Symbol	Min.	Typ.	Max.	Unit	Remark
Forward Current	I _F	--	20	--	mA	3 LEDs
Forward Voltage	V _F	--	3.2	--	V	
Backlight Power Consumption	W _{BL}	--	192	--	mW	

Note1: Figure below shows the connection of backlight LED.

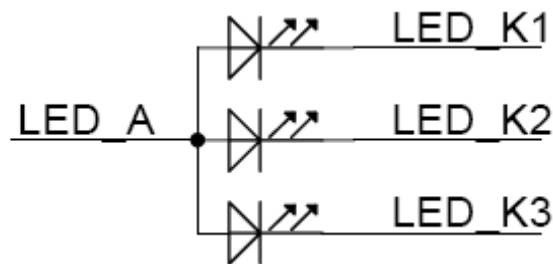

Note 2: One LED : I_F =20mA, V_F =3.2V

Note 3: The life of LED : 20,000 hours



4.3 Block Diagram

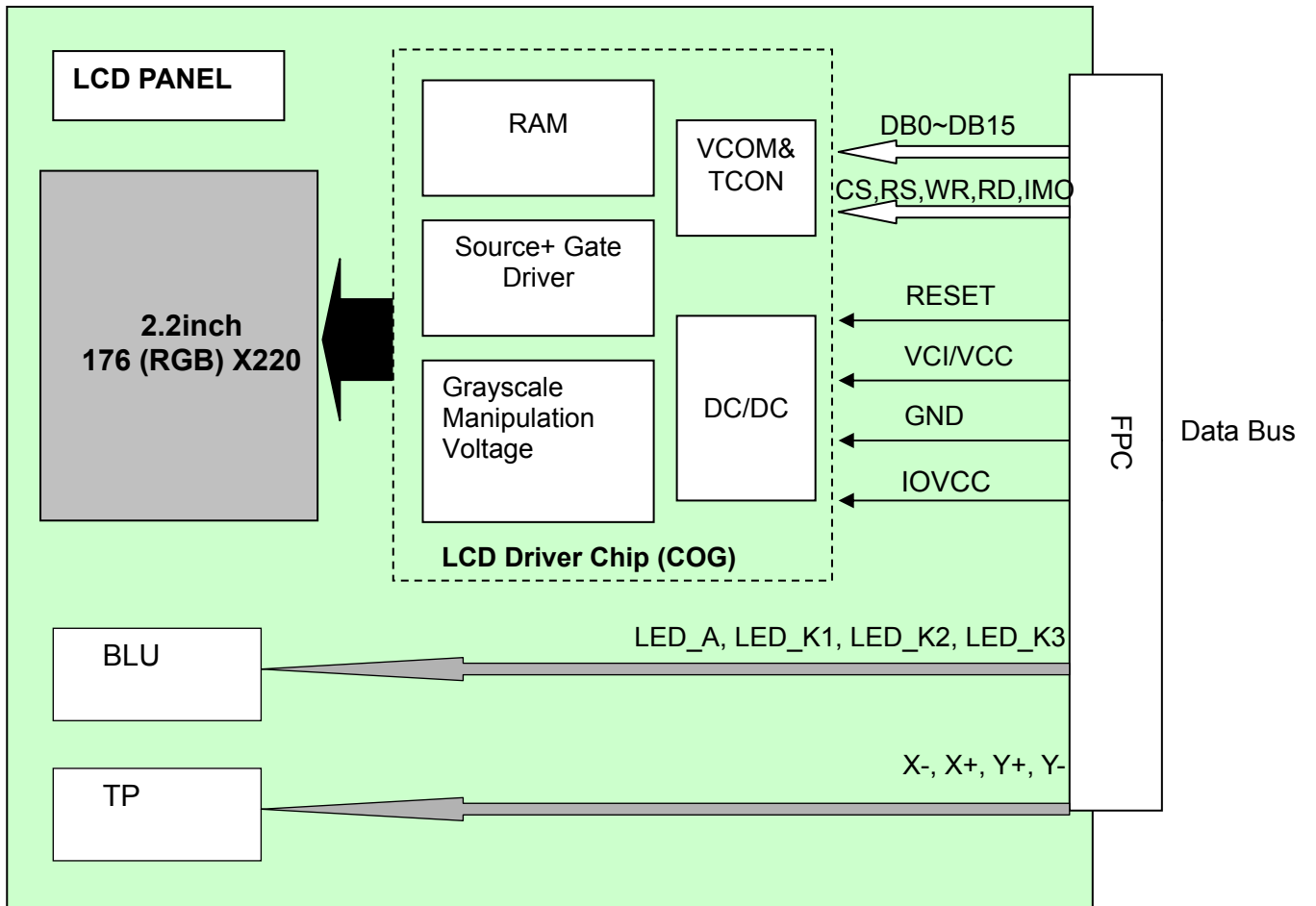



5 Timing Chart

5.1 Timing Parameter

Signal	Item	Symbol	Unit	Min	Max	Remark
RS	Address setup time	t_{AS}	ns	0	—	
	Address hold time	t_{AH}	ns	10	—	
/CS	Chip select "H" pulse width	t_{CHW}		0	—	
	Chip select setup time	t_{AS}	ns	15	—	
	Chip select wait time	t_{CSF}	ns	10	—	
	Chip select hold time	t_{CSH}	ns	10	—	
/RD(ID)	Read cycle(ID)	t_{RC}	ns	160	—	When read ID data
	Control pulse "H" duration(ID)	t_{RDH}	ns	90	—	
	Control pulse "L" duration(ID)	t_{RDL}	ns	45	—	
/RD(FM)	Read cycle(FM)	t_{RCFM}	ns	450	—	When read from frame memory
	Control pulse "H" duration(FM)	t_{RDHFM}	ns	90	—	
	Control pulse "L" duration(FM)	t_{RDLFM}	ns	355	—	
DB15~DB0	Data setup time	t_{DST}	ns	10	—	
	Data hold time	t_{DHT}	ns	10	—	
	Read access time(ID)	t_{RAT}	ns	—	40	
	Read access time(FM)	t_{RATFM}	ns	—	340	
	Output disable time	t_{ODH}	ns	20	80	
/WR	Write cycle	t_{WC}	ns	66	—	
	Control pulse "H" duration	t_{WRH}	ns	15	—	
	Control pulse "L" duration	t_{WRL}	ns	15	—	

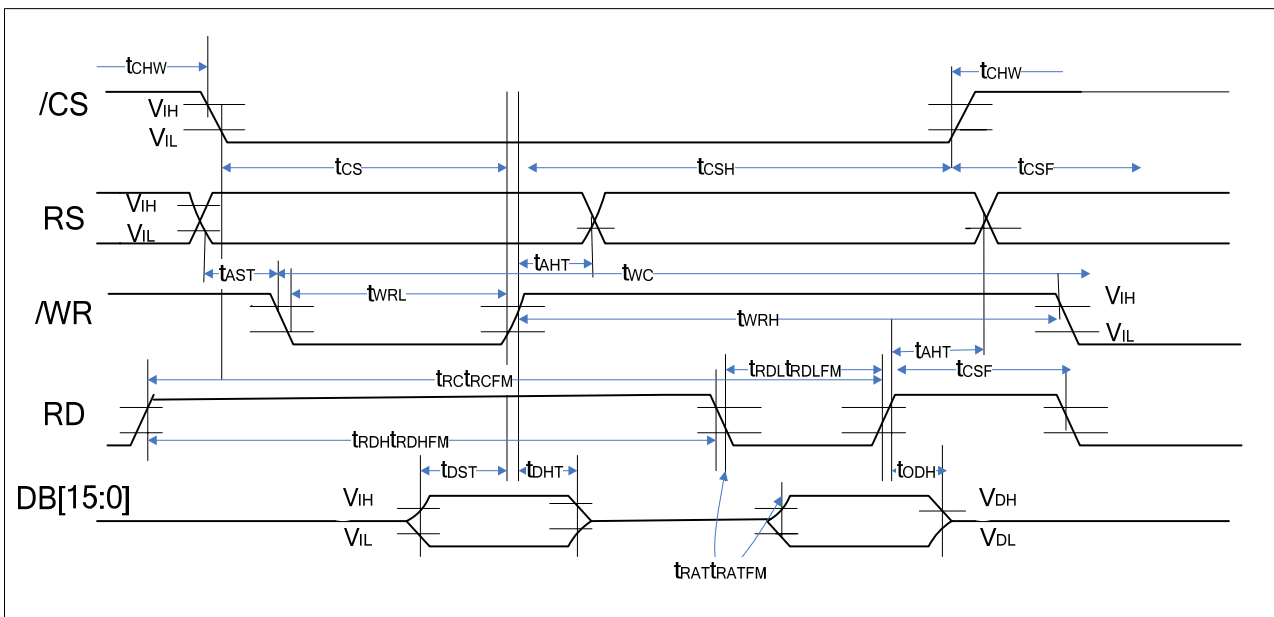

The information contained herein is the exclusive property of SHANGHAI TIANMA MICRO-ELECTRONICS Corporation, and shall not be distributed, reproduced, or disclosed in whole or in part without prior written permission of SHANGHAI TIANMA MICRO-ELECTRONICS Corporation.



Reset timing

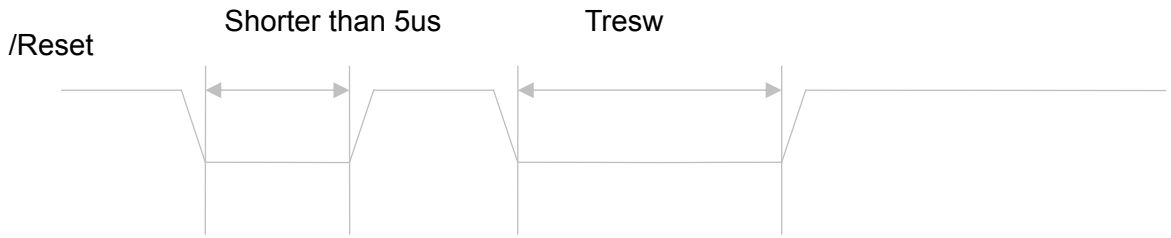

Note1: Tresw(at least 10us)

5.2 Register Write/Read Timing

5.2.1 Register Write Timing

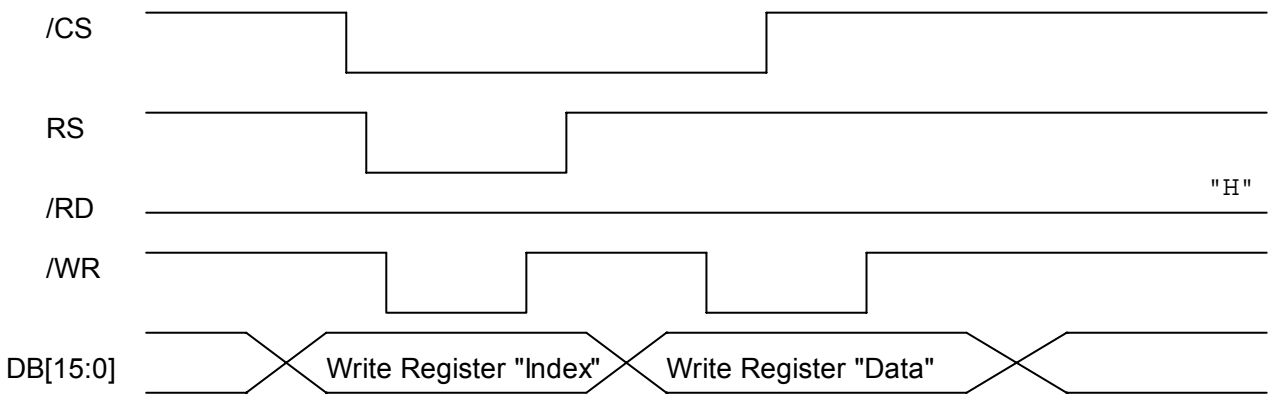

Figure 5.2.1 16-bit System Bus Interface Timing(Register Write Timing)

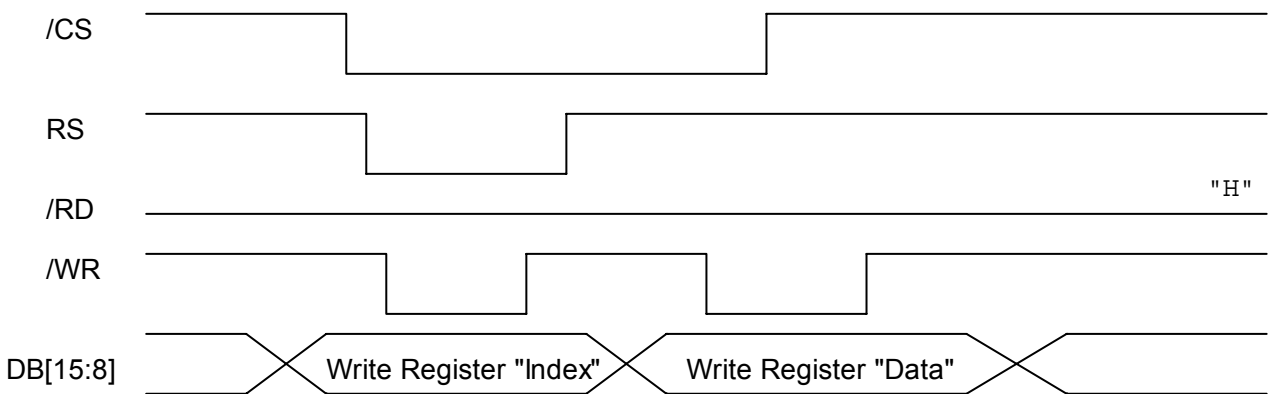

Figure 5.2.2 8-bit System Bus Interface Timing(Register Write Timing)



5.3 GRAM Write Timing

5.3.1 GRAM Write Timing

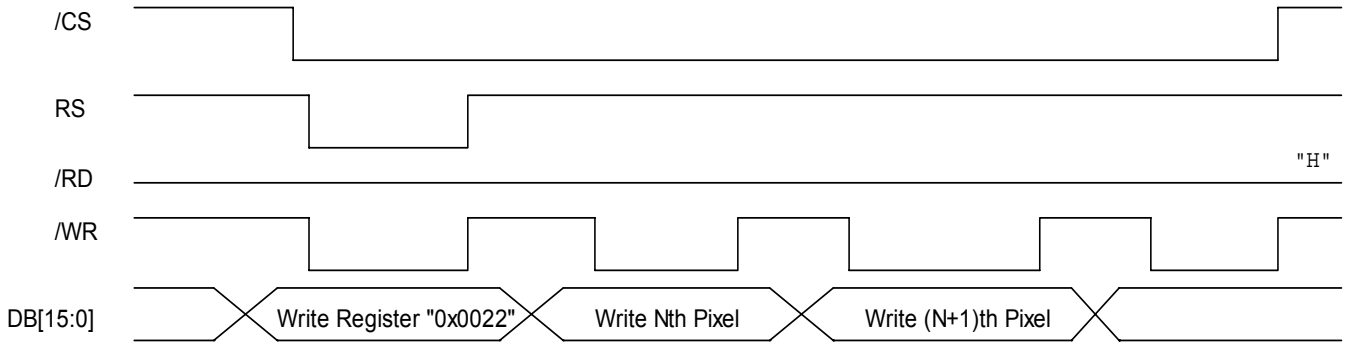

Figure 5.3.1 16-bit Write data for RGB 5-6-5-bits input(GRAM Write Timing)

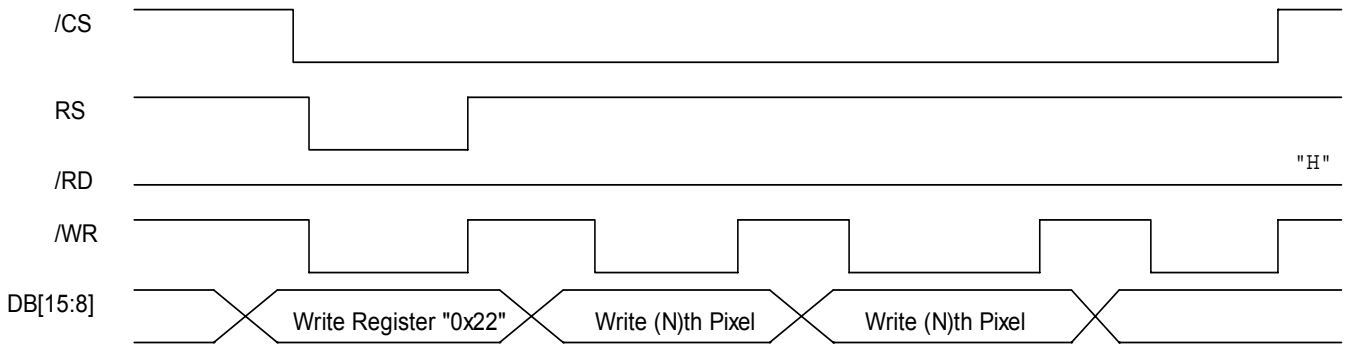

Figure 5.3.2 8-bit Write data for RGB 5-6-5-bits input(GRAM Write Timing)



Display mode

Register	DB15	DB14	DB13	DB12	DB11	DB10	DB9	DB8	DB7	DB6	DB5	DB4	DB3	DB2	DB1	DB0	Command
Command	X	X	X	X	X	X	X	X	0	0	1	0	0	0	1	0	22H
17H	DB15	DB14	DB13	DB12	DB11	DB10	DB9	DB8	DB7	DB6	DB5	DB4	DB3	DB2	DB1	DB0	Color
03h	X	X	X	X	R3	R2	R1	R0	G3	G2	G1	G0	B3	B2	B1	B0	4K-Color
05h	R4	R3	R2	R1	R0	G5	G4	G3	G2	G1	G0	B4	B3	B2	B1	B0	65K-Color
06h	R5	R4	R3	R2	R1	R0	X	X	G5	G4	G3	G2	G1	G0	X	X	262K-Color
	B5	B4	B3	B2	B1	B0	X	X	R5	R4	R3	R2	R1	R0	X	X	
	G5	G4	G3	G2	G1	G0	X	X	B5	B4	B3	B2	B1	B0	X	X	

16-bit Bus GRAM mode select

Register	DB15	DB14	DB13	DB12	DB11	DB10	DB9	DB8	DB7	DB6	DB5	DB4	DB3	DB2	DB1	DB0	Command
Command	X	X	X	X	X	X	X	X	0	0	1	0	0	0	1	0	22H
17H	DB15	DB14	DB13	DB12	DB11	DB10	DB9	DB8	DB7	DB6	DB5	DB4	DB3	DB2	DB1	DB0	Color
03h	R3	R2	R1	R0	G3	G2	G1	G0	X	X	X	X	X	X	X	X	4K-Color
	B3	B2	B1	B0	R3	R2	R1	R0									
	G3	G2	G1	G0	B3	B2	B1	B0									
05h	R4	R3	R2	R1	R0	G5	G4	G3	X	X	X	X	X	X	X	X	65K-Color
	G2	G1	G0	B4	B3	B2	B1	B0									
06h	R5	R4	R3	R2	R1	R0	X	X	X	X	X	X	X	X	X	X	262K-Color
	B5	B4	B3	B2	B1	B0	X	X	X	X	X	X	X	X	X	X	
	G5	G4	G3	G2	G1	G0	X	X	X	X	X	X	X	X	X	X	

8-bit Bus GRAM mode select

The information contained herein is the exclusive property of SHANGHAI TIANMA MICRO-ELECTRONICS Corporation, and shall not be distributed, reproduced, or disclosed in whole or in part without prior written permission of SHANGHAI TIANMA MICRO-ELECTRONICS Corporation.



5.4 Power On/Off Sequence

5.4.1 Power on Sequence

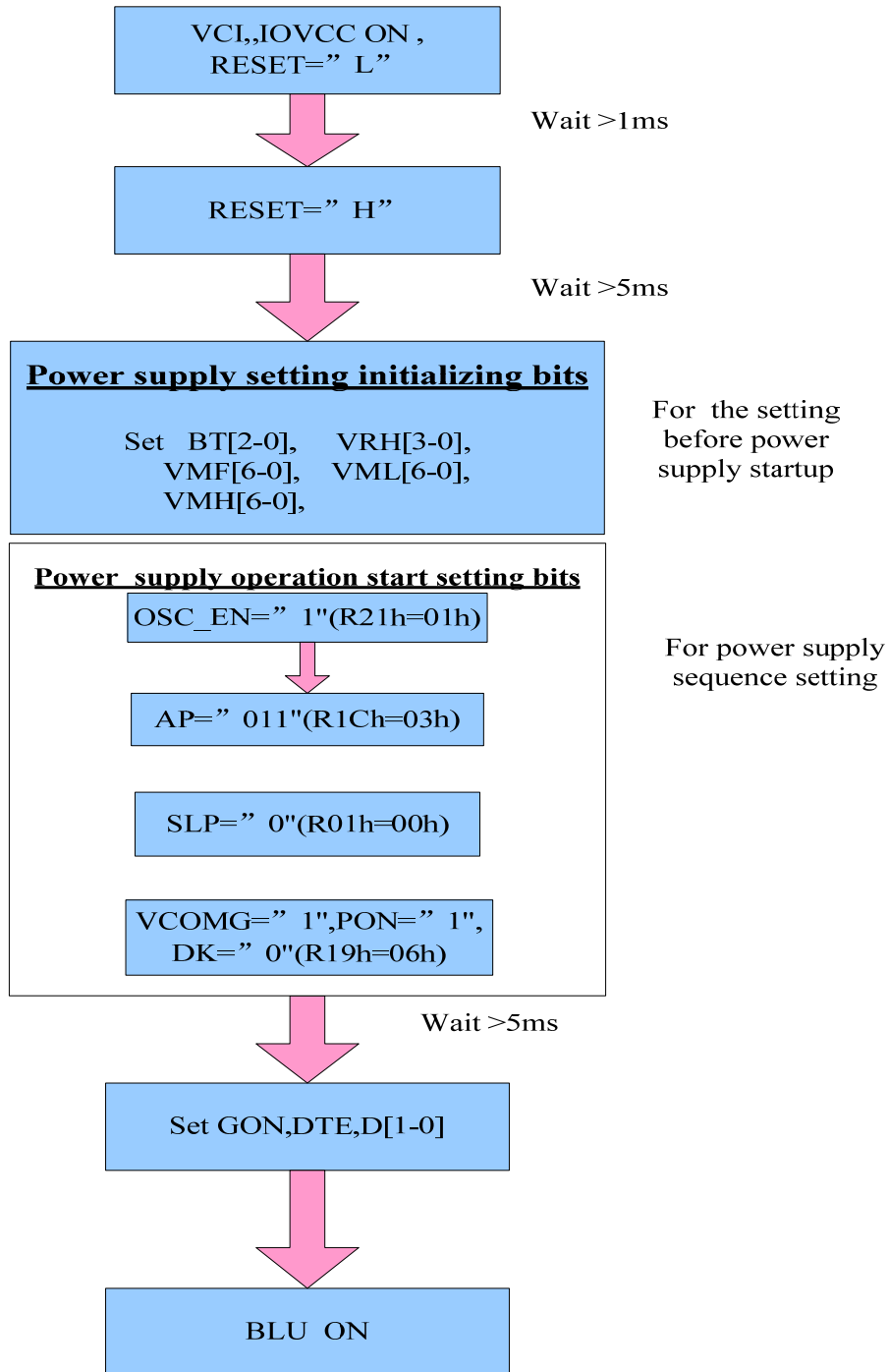



5.4.2 Power off Sequence

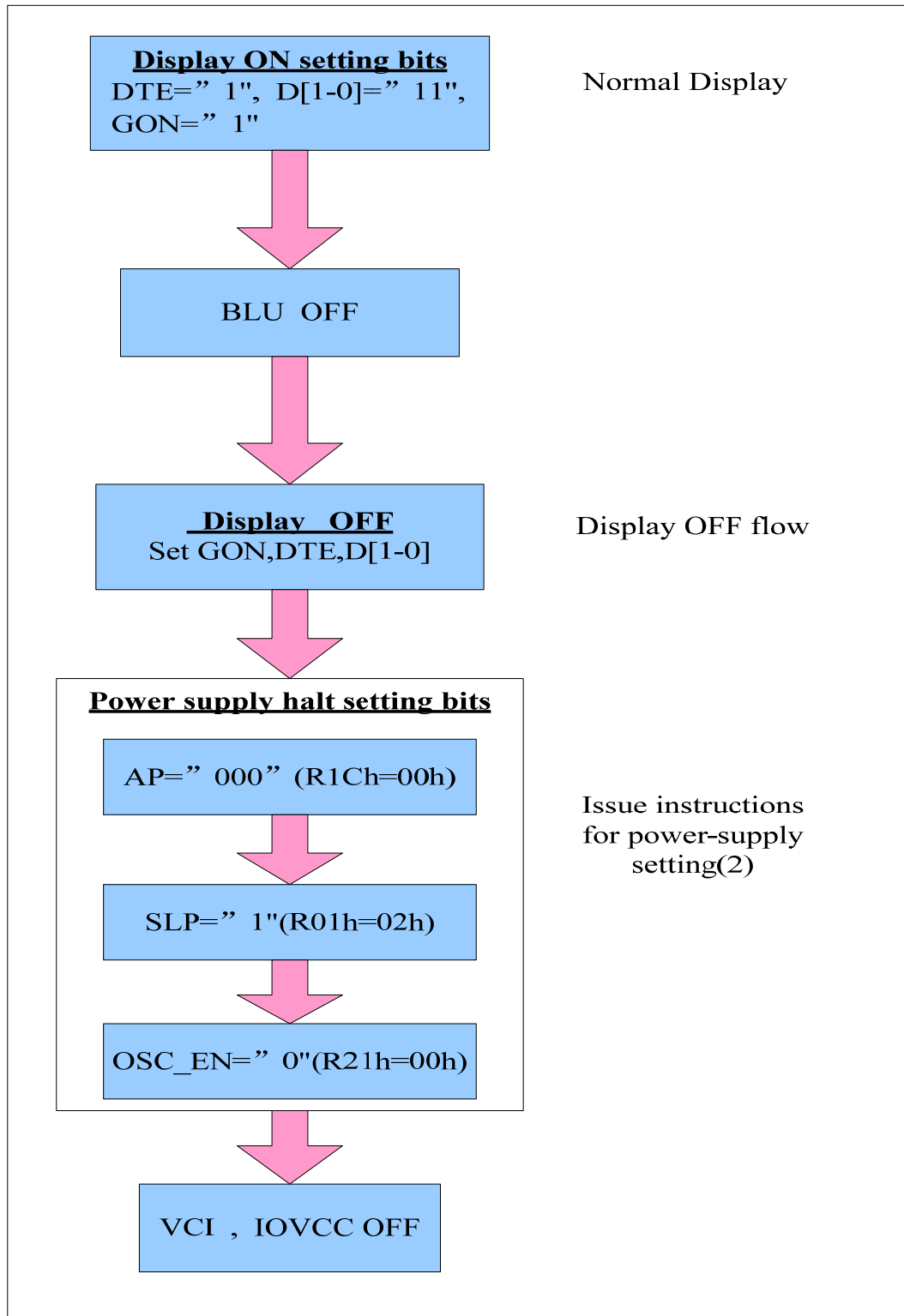



6 Optical Characteristics

6.1 Optical Specification

Ta=25°C

Item	Symbol	Condition	Min.	Typ.	Max.	Unit	Remark
View Angles	θT	$CR \cong 10$	45	50	-	Degree	Note 2
	θB		15	20	-		
	θL		40	45	-		
	θR		40	45	-		
Contrast Ratio	CR	$\theta=0^\circ$	250	350	-		Note1 Note3
Response Time	T_{ON}	25°C	-	20	30	ms	Note1 Note4
	T_{OFF}						
Chromaticity	White	x	Backlight is on	0.287	0.292	0.297	Note5, Note1
		y		0.307	0.312	0.317	
	Red	x		0.582	0.587	0.592	
		y		0.332	0.337	0.342	
	Green	x		0.320	0.325	0.330	
		y		0.549	0.564	0.569	
	Blue	x		0.142	0.147	0.152	
		y		0.081	0.086	0.091	
Uniformity	U		-	80	-	%	Note1 Note6
NTSC			-	50	-	%	Note 5
Luminance	L		200	250	-	cd/m ²	Note1 Note7

Test Conditions:

1. $V_F = 3.2V$, $I_F = 20mA$ (Backlight current for each LED), the ambient temperature is 25°C.
2. The test systems refer to Note 1 and Note 2.



Note 1: Definition of optical measurement system.

The optical characteristics should be measured in dark room. After 5 minutes operation, the optical properties are measured at the center point of the LCD screen. All input terminals LCD panel must be ground when measuring the center area of the panel.

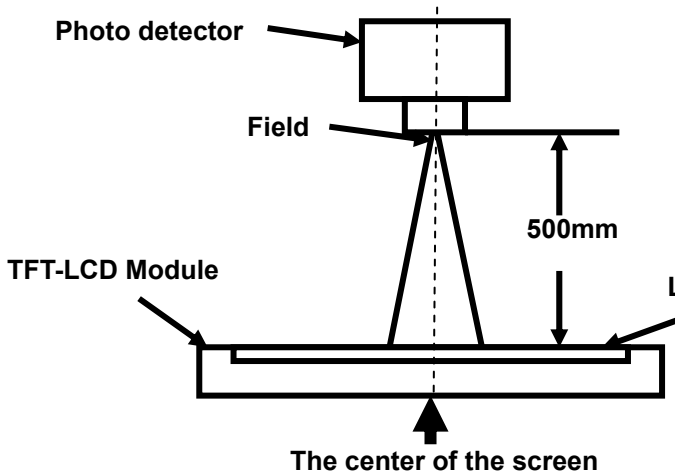

Item	Photo detector	Field
Contrast Ratio	SR-3A	1°
Luminance		
Chromaticity		
Lum Uniformity		
Response Time	BM-7A	2°

Note 2: Definition of viewing angle range and measurement system.

viewing angle is measured at the center point of the LCD by CONOSCOPE(ergo-80).

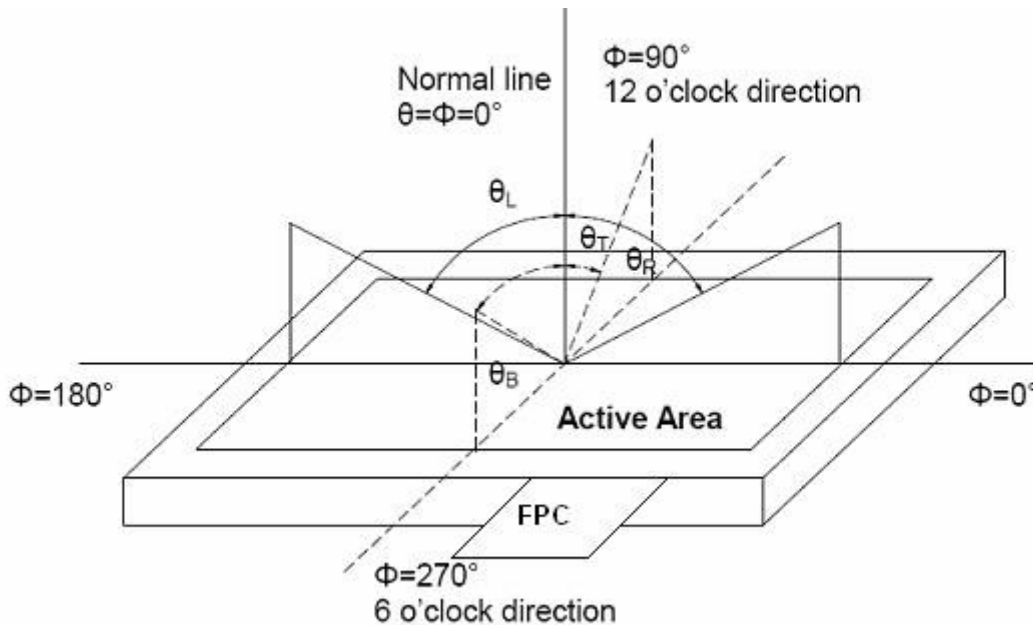

Fig. 1 Definition of viewing angle



Note 3: Definition of contrast ratio

$$\text{Contrast ratio (CR)} = \frac{\text{Luminance measured when LCD is on the "White" state}}{\text{Luminance measured when LCD is on the "Black" state}}$$

“White state “:The state is that the LCD should be driven by V_{white} .

“Black state”: The state is that the LCD should be driven by V_{black} .

V_{white} : To be determined V_{black} : To be determined.

Note 4: Definition of Response time

The response time is defined as the LCD optical switching time interval between “White” state and “Black” state. Rise time (T_{ON}) is the time between photo detector output intensity changed from 90% to 10%. And fall time (T_{OFF}) is the time between photo detector output intensity changed from 10% to 90%.

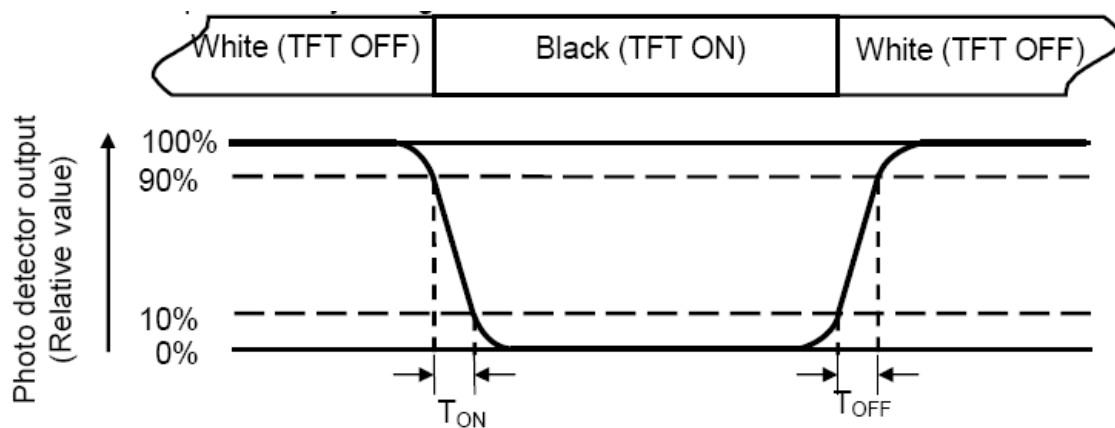

Note 5: Definition of color chromaticity (CIE1931)

Color coordinates measured at center point of LCD.



Note 6: Definition of Luminance Uniformity

Active area is divided into 9 measuring areas (Refer Fig. 2). Every measuring point is placed at the center of each measuring area.

$$\text{Luminance Uniformity}(U) = L_{\min} / L_{\max}$$

L-----Active area length W----- Active area width

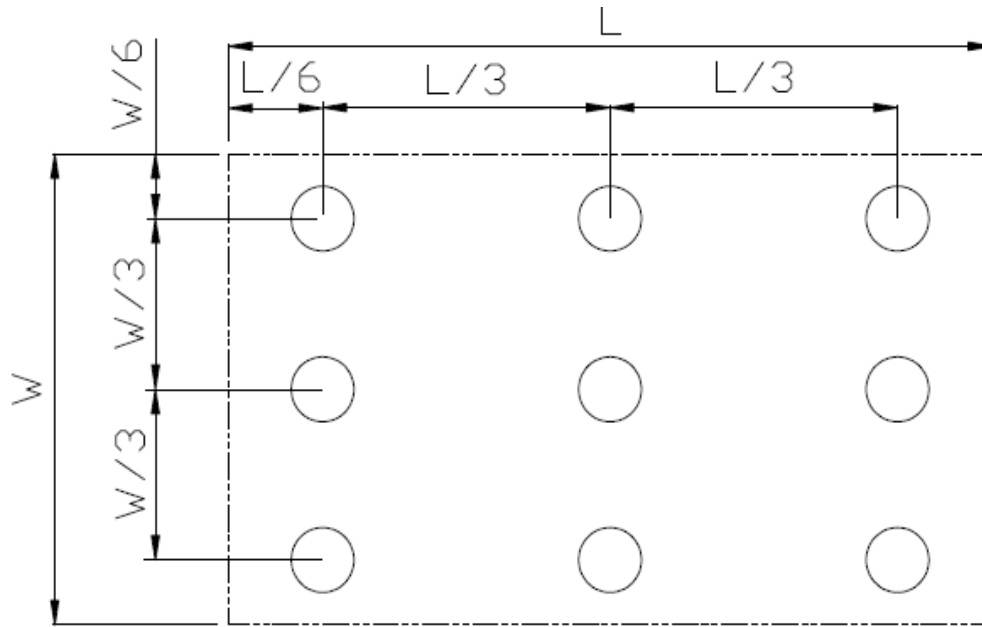

Fig. 2 Definition of uniformity

Lmax: The measured maximum luminance of all measurement position.

Lmin: The measured minimum luminance of all measurement position.

Note 7: Definition of Luminance:

Measure the luminance of white state at center point.



7 Environmental / Reliability Tests

No	Test Item	Condition	Remarks
1	High Temperature Operation	Ts=+60°C, 240hrs	Note1 IEC60068-2-2,GB2423.2—89
2	Low Temperature Operation	Ta=-20°C, 240hrs	IEC60068-2-1 GB2423.1—89
3	High Temperature Storage	Ta=+70°C, 240hrs	IEC60068-2-2, GB2423.2—89
4	Low Temperature Storage	Ta=-30°C, 240hrs	IEC60068-2-1 GB2423.1—89
5	High Temperature & High Humidity Storage	Ta=+60°C, 90% RH 240 hours	Note2 IEC60068-2-3, GB/T2423.3—2006
6	Thermal Shock (Non-operation)	-30°C 30 min~+70°C 30 min, Change time:5min, 20 Cycles	Start with cold temperature, End with high temperature, IEC60068-2-14,GB2423.22—87
7	Electro Static Discharge (Operation)	C=150pF, R=330Ω, 5points/panel Air:±8KV, 5times; Contact:±4KV, 5 times; (Environment: 15°C~35°C, 30%~60%, 86Kpa~106Kpa)	IEC61000-4-2 GB/T17626.2—1998
8	Vibration (Non-operation)	Frequency range:10~55Hz, Stroke:1.5mm Sweep:10Hz~55Hz~10Hz 2 hours for each direction of X.Y.Z. (6 hours for total)(Package condition)	IEC60068-2-6 GB/T2423.10—1995
9	Shock (Non-operation)	60G 6ms, ±X,±Y,±Z 3times, for each direction	IEC60068-2-27 GB/T2423.5—1995
10	Package Drop Test	Height:80 cm, 1 corner, 3 edges, 6 surfaces	IEC60068-2-32 GB/T2423.8—1995

Note1: Ts is the temperature of panel's surface.

Note2: Ta is the ambient temperature of sample.



9 Packing Drawing

TBD



10 Precautions for Use of LCD Modules

10.1 Handling Precautions

- 10.1.1 The display panel is made of glass. Do not subject it to a mechanical shock by dropping it from a high place, etc.
- 10.1.2 If the display panel is damaged and the liquid crystal substance inside it leaks out, be sure not to get any in your mouth, if the substance comes into contact with your skin or clothes, promptly wash it off using soap and water.
- 10.1.3 Do not apply excessive force to the display surface or the adjoining areas since this may cause the color tone to vary.
- 10.1.4 The polarizer covering the display surface of the LCD module is soft and easily scratched. Handle this polarizer carefully.
- 10.1.5 If the display surface is contaminated, breathe on the surface and gently wipe it with a soft dry cloth. If still not completely clear, moisten cloth with one of the following solvents:
 - Isopropyl alcohol
 - Ethyl alcoholSolvents other than those mentioned above may damage the polarizer. Especially, do not use the following:
 - Water
 - Ketone
 - Aromatic solvents
- 10.1.6 Do not attempt to disassemble the LCD Module.
- 10.1.7 If the logic circuit power is off, do not apply the input signals.
- 10.1.8 To prevent destruction of the elements by static electricity, be careful to maintain an optimum work environment.
 - 10.1.8.1 Be sure to ground the body when handling the LCD Modules.
 - 10.1.8.2 Tools required for assembly, such as soldering irons, must be properly ground.
 - 10.1.8.3 To reduce the amount of static electricity generated, do not conduct assembly and other work under dry conditions.
 - 10.1.8.4 The LCD Module is coated with a film to protect the display surface. Be care when peeling off this protective film since static electricity may be generated.

10.2 Storage precautions

- 10.2.1 When storing the LCD modules, avoid exposure to direct sunlight or to the light of fluorescent lamps.
- 10.2.2 The LCD modules should be stored under the storage temperature range. If the LCD modules will be stored for a long time, the recommend condition is:
Temperature : 0°C ~ 40°C Relatively humidity: ≤80%
- 10.2.3 The LCD modules should be stored in the room without acid, alkali and harmful gas.

10.3 Transportation Precautions:

The LCD modules should be no falling and violent shocking during transportation, and also should avoid excessive press, water, damp and sunshine.