

mass integrated

global part distribution • product lifecycle partner
excess inventory management • value-ad service provider



Data sheet provided by Mass Integrated

massintegrated.com • displayalliance.com

Please call +1.978.465.6190
Email: sales@massintegrated.com



ISO 9001: 2008

Mass Integrated complies with all DMCA takedown notices. Please send a formal DMCA Takedown Notice to Mass Integrated Systems, Inc. • 18 Henry Graf Jr. Road, Unit 1 • Newburyport, MA 01950.

HITACHI

KAOHSIUNG HITACHI
ELECTRONICS CO.,LTD
P.O. BOX 26-27
2,13TH EAST ST. K.E.P.Z.
KAOHSIUNG TAIWAN R.O.C.
TEL:(07) 821-5811 (7 LINE)
FAX:(07) 821-5815

FOR MESSRS : _____

DATE :Dec.19,2005

CUSTOMER'S ACCEPTANCE SPECIFICATIONS

TX18D16VM1CAB

C O N T E N T S

No.	ITEM	SHEET No.	PAGE
1	COVER	7B64PS 2701-TX18D16VM1CAB-1	1-1/1
2	RECORD OF REVISION	7B64PS 2702-TX18D16VM1CAB-1	2-1/1
3	GENERAL DATA	7B64PS 2703-TX18D16VM1CAB-1	3-1/1
4	ABSOLUTE MAXIMUM RATINGS	7B64PS 2704-TX18D16VM1CAB-1	4-1/1
5	ELECTRICAL CHARACTERISTICS	7B64PS 2705-TX18D16VM1CAB-1	5-1/1
6	OPTICAL CHARACTERISTICS	7B64PS 2706-TX18D16VM1CAB-1	6-1/1~6-2/2
7	BLOCK DIAGRAM	7B64PS 2707-TX18D16VM1CAB-1	7-1/1
8	INTERFACE PIN CONNECTION	7B64PS 2708-TX18D16VM1CAB-1	8-1/2~2/2
9	INTERFACE TIMING	7B64PS 2709-TX18D16VM1CAB-1	9-1/3~9-3/3
10	DIMENSIONAL OUTLINE	7B64PS 2710-TX18D16VM1CAB-1	10-1/2~2/2
11	DESIGNATION OF LOT MARK	7B64PS 2711-TX18D16VM1CAB-1	11-1/1
12	COSMETIC SPECIFICATIONS	7B64PS 2712-TX18D16VM1CAB-1	12-1/3-3/3
13	PRECAUTIONS	7B64PS 2713-TX18D16VM1CAB-1	13-1/4-4/4

Please return 1 copy with your signature on this page for approval.

When product will be discontinued, customer will be informed by
HITACHI with twelve months prior to discontinuation.

ACCEPTED BY: _____

PROPOSED BY: *Dan Cheng*

KAOHSIUNG HITACHI ELECTRONICS CO.,LTD.	Sh. No.	7B64PS 2701-TX18D16VM1CAB-1	PAGE	1-1/1
---	------------	-----------------------------	------	-------

RECORD OF REVISION

DATE	SHEET No.	SUMMARY

3. GENERAL DATA

The specifications are applied to the following TFT-LCD Module with Back-light unit.

Note : Inverter device for Back-Light is not built in this module.

(1) Part Name	TX18D16VM1CAB	
(2) Effective Display Area	(H)152.4 x (V)91.44	[mm]
(3) Display Dots	(H)(800x3) x (V)480	[dots]
Display Pixels	(H800 x V480)	[Pixels]
(4) Pixel Pitch	(H)0.1905 x (V)0.1905	[mm]
(5) Color Pixel Arrangement	R+G+B Vertical Stripe	
(6) Display Mode	Transmissive Mode, Normally White Mode	
(7) Surface Polarizing Film	Polarizing Film with Antiglare Coating	
(8) Number of Colors	262k	[Colors]
(9) Interface	C-MOS, R.G.Bx6 bit Digital each	
(10) Color Saturation	60%(typ.) for NTSC	
(11) Viewing Direction	12 O'clock.(The direction it's hard to be discolored)	
(12) Backlight	CCFL, 1pc Side-light type(U shaped)	
(13) Dinensions Outline	(H)165.0(typ.) x (V)106.0(typ.)x(t)10.5(max.)	[mm].
(14) Weight	Approximately 170	[g]

4. ABSOLUTE MAXIMUM RATINGS

4.1 ENVIRONMENTAL ABSOLUTE MAXIMUM RATINGS

I T E M	OPERATING		NON-OPERATION		UNIT	NOTE
	MIN.	MAX.	MIN.	MAX.		
Temperature	(-20)	(70)	(-30)	(80)	°C	1) 2) 5)
Humidity	2)		2)		%RH	1)
Vibration	-	4.9(0.5G)	-	19.6(2G)	m/s ²	3)
Shock	-	29.4(3G)	-	490(50G)	m/s ²	4)
Corrosive Gas	Not Acceptable		Not Acceptable			
Illumination at LCD Surface	-	50,000	-	50,000	lx	

Notes 1) "Temperature" and "Humidity" shall be measured on the panel surface.

The ratings apply to every part of this module and shall not be exceeded.

The operating temperature only guarantee the display can be operated; regarding the contrast, response time, illumination and other features related to the quality are judged by Ta=25°C condition.

Generally the illumination will down and LCD response time will becomes slower when the display operated under a lower temperature environment.

2) Ambient temp . Ta ≤ 40°C : 85%RH Max. Without condensation.

Ta > 40°C : Absolute humidity must be lower than the humidity of 85%RH at 40°C. Without condensation.

3) Frequency of the vibration shall be between 20 Hz and 50 Hz. (except resonance point)

4) Pulse width of the shock shall be 10 ms.

5) In Non-operation condition (Ta > 70°C) the TFT-LCD module should be put within 48 hrs. In Non-operation condition (Ta < -20°C) the TFT-LCD module should be put within 48 hrs and without condensation.

4.2 ELECTRICAL ABSOLUTE MAXIMUM RATINGS

(1) TFT-LCD MODULE

V_{SS}=0V

ITEM	SYMBOL	MIN.	MAX.	UNIT	NOTE
Power Supply Voltage for Logic	VDD	0	4.0	V	
Input Signal Voltage for logic	VI	-0.3	VDD+0.3	V	1)
Electrostatic Durability	VESD0	± 100		V	2),3)
	VESD1	± 8		kV	2),4)

Notes 1) The specification is applied to pixel data signal, timing signal and clock signal.

2) Discharge circuit to be connected : 200 pF-250 Ω, Environmental : 25°C-70% RH

3) The specification is applied to I/F connector pins.

4) The specification is applied to the surface of both a metal bezel and a LCD panel.

(2) BACK-LIGHT UNIT

GND=0V

ITEM	SYMBOL	MIN.	MAX.	UNIT	NOTE
Lamp Current	IL	-	7.0	mArms	1)
Lamp Voltage	VL	-	2000	Vrms	2)

Notes 1) To be measured at GND terminal side

2) The specification is applied at connector pins for back-light units.

5. ELECTRICAL CHARACTERISTICS

5.1 TFT-LCD DISPLAY MODULE

Ta=25°C , VSS=0V

Item	Symbol	Min.	Typ.	Max.	Unit	Note
Power Supply Voltage	VDD	3.0	3.3	3.6	V	
Input Voltage for Logic Circuits	Hi	VIH	2.0	-	VDD	1)
	Lo	VIL	VSS	-	0.8	V
Power Supply Current	IDD	-	250	350	mA	2),3)
Vsync Frequency	fV	-	60	75	Hz	
Hsync Frequency	fH	-	31.6	39.2	kHz	
DCLK Frequency	fCLK	-	33.3	40	MHz	

Notes 1) The specification is applied to pixel data signal , timing signal and clock signal.

2) fV=60Hz , fCLK=33.3MHz , VDD=3.3V ,DC Current.

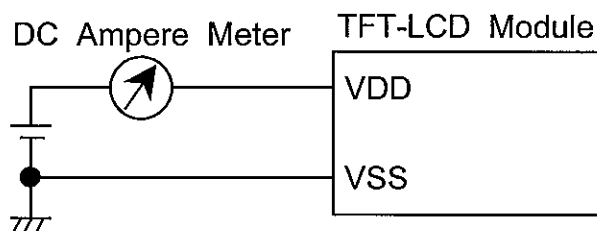

Typical value is measured when displaying Black raster.

Maximum is measured when displaying Vertical-stripe pattern of 2 pixel pitch.

3) Current capacity for VDD power source should be larger than 1A.

This TFT-LCD Module has a fuse (0.4A).

5.2 BACK-LIGHT UNIT

Ta=25°C

Item	Symbol	Min.	Typ.	Max.	Unit	Note
Lamp Current	IL	2.0	-	4.0	mArms	1),3)
Lamp Voltage	VL	-	1000	-	Vrms	
Frequency	fL	50	-	70	kHz	2)
Starting Lamp Voltage	VS	1400	-	2000	Vrms	Ta=25°C
		1600	-	2000		Ta= 0°C

Notes 1) Larger IL causes the shorter life of a CCFL.

2) Frequency of power supply for a CCFL may cause interference with Hsync frequency and causes beat or flicker on the display.

Therefore , lamp frequency shall be as different as possible from Hsync frequency in order to avoid the interference.

3) To be measured at GND terminal side

4) Starting Lamp Voltage should be kept 1 sec at least.

5) The inverter should be built-in a safety circuit which detects over current , over voltage and distorted wave form of lamp current.

6. OPTICAL CHARACTERISTICS

The following items are measured on the conditions that this unit operation (TFT-LCD and the Back-light) and measuring systems are stable. It takes about 15 minutes.

The ambient light excluding the Back-light unit is nothing.

- Measuring equipment: TOPCON BM-7, Prichard 1908A, or equivalent
- Measuring point : Active area center

Ta=25°C VDD=3.3V, fV=60Hz, IL=4.0mA

ITEM		SYMBOL	CONDITIONS	MIN.	TYP.	MAX.	UNIT	NOTE
Contrast Ratio		CR	$\theta = 0^\circ$ 1)	100	200	-		2)
Response Time	RISE	ton		-	20	40	ms	3)
	FALL	toff		-	10	20	ms	3)
Brightness (White)		Bwh		-	(600)	-	cd/m ²	
Brightness Uniformity		Buni		70	-	-	%	4)
Color Position on CIE	Red	x		-	(0.62)	-	-	
		y		-	(0.34)	-		
	Green	x		-	(0.29)	-		
		y		-	(0.60)	-		
	Blue	x		-	(0.14)	-		
		y	-	(0.07)	-			
	White	x	-	(0.30)	-			
		y	-	(0.31)	-			
Viewing Angle (CR ≥ 10)	x - x'	θx	$\theta = 0^\circ$	50	-	-	deg.	1)
		$\theta x'$	$\theta = 180^\circ$	50	-	-		
	Y - y'	θy	$\theta = 90^\circ$	50	-	-		
		$\theta y'$	$\theta = 270^\circ$	50	-	-		

Note 1) Definition of Viewing Angle

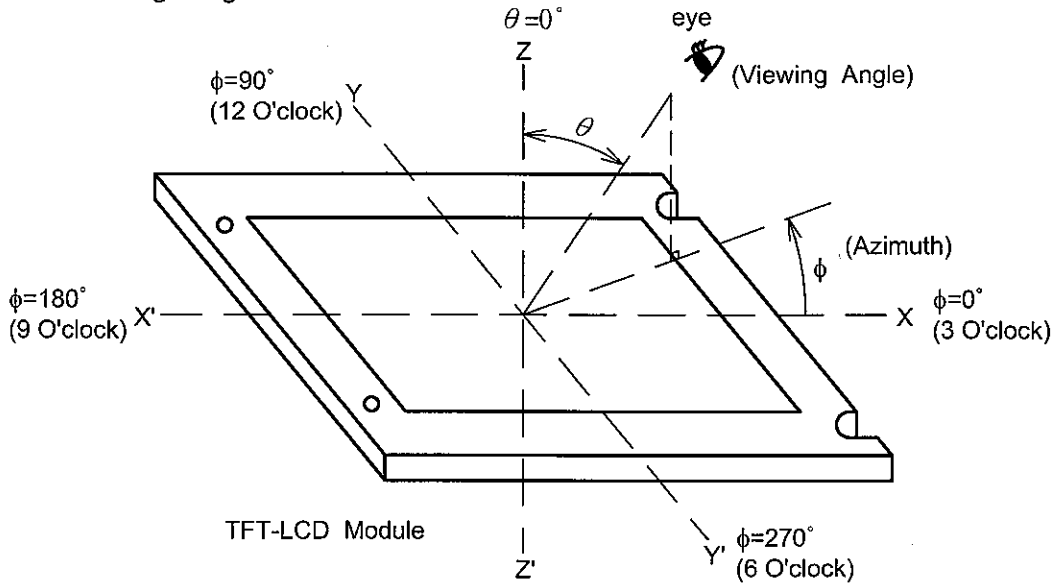

2) Definition of Contrast Ratio(CR) :

$$CR = \frac{\text{Luminance at displaying WHITE}}{\text{Luminance at displaying BLACK}}$$

3) Definition of Response Time

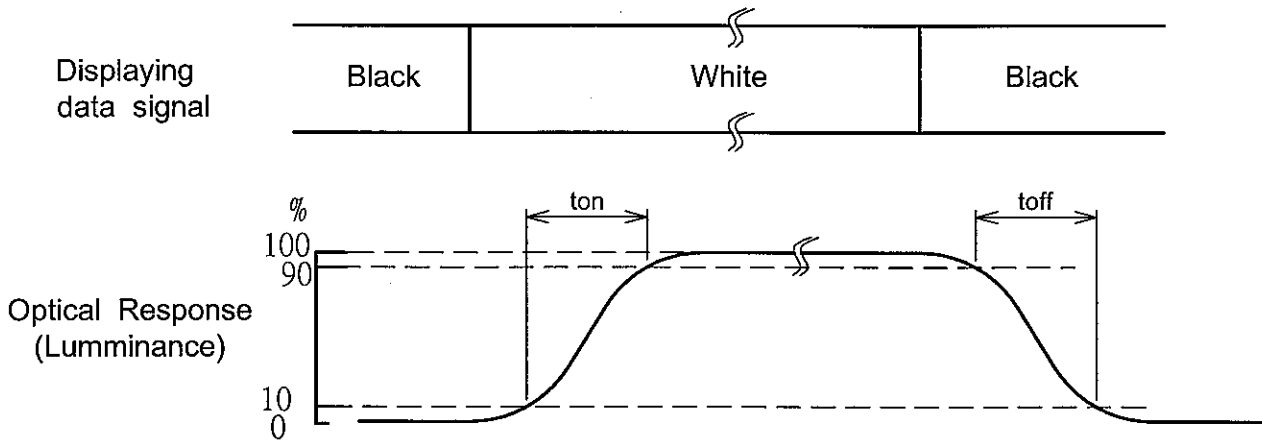

4) Definition of Brightness Uniformity

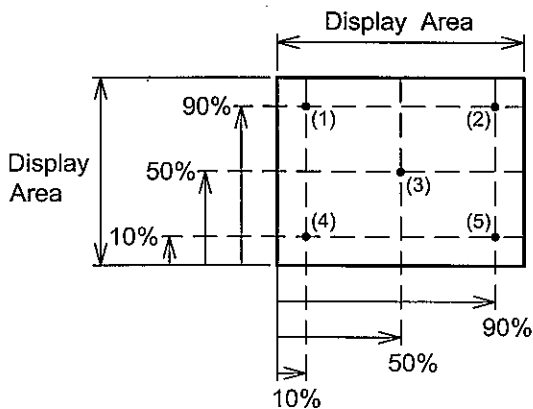

The brightness uniformity (Buni) is defined as the following equation.

$$Buni = \frac{B_{min}}{B_{max}} \times 100$$

where, B_{max} = Maximum brightness among 5 measuring points
 B_{min} = Minimum brightness among 5 measuring points

• : measuring point

7.BLOCK DIAGRAM

7.1 TFT-LCD MODULE

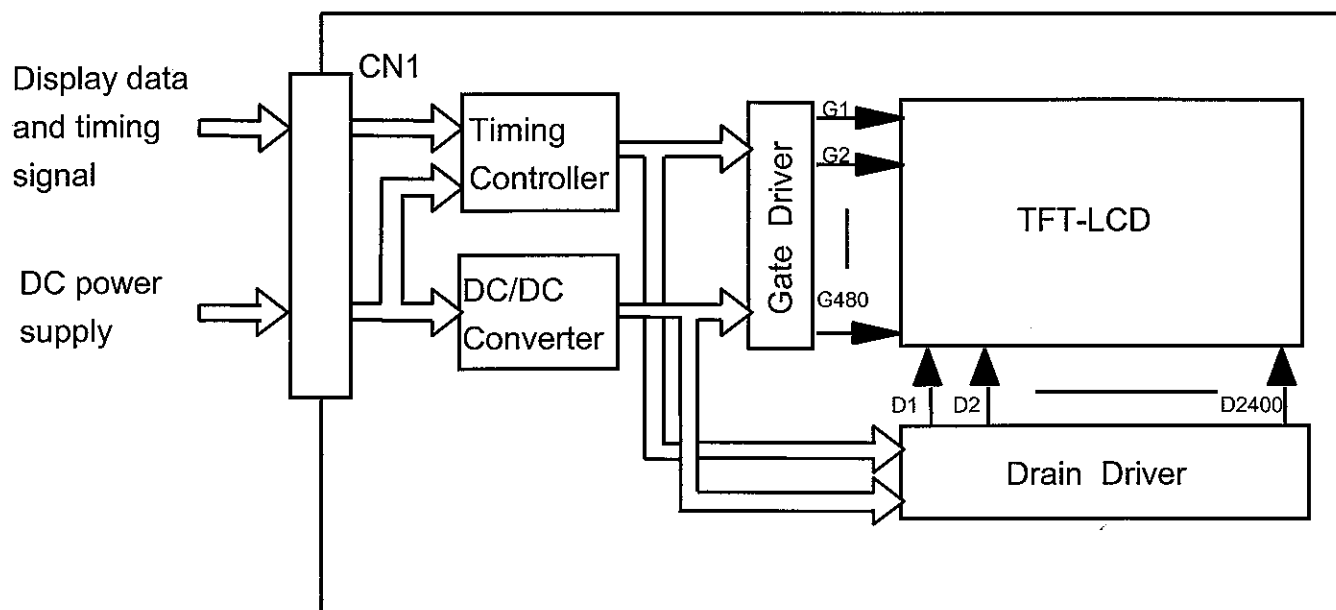

7.2 BACK-LIGHT UNIT

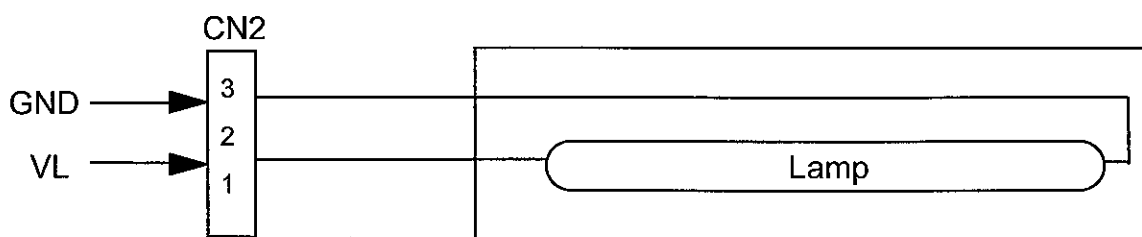

Color of wires from CCFL to CN2

3 (GND) : White

1 (VL) : Pink

8. INTERFACE PIN CONNECTION

8.1 TFT-LCD MODULE

CN1 《JAE ; FA5B040HF1R3000》

Pin No.	Symbol	Description	Note
1	VDD	Power Supply (typ.+3.3V)	1)
2	VDD		
3	VDD		
4	VDD		
5	NC	Non-Connect	4)
6	DTMG	Display Timing	
7	VSS	GND (0V)	2)
8	NC	Non-Connect	4)
9	VSS	GND (0V)	2)
10	(IC)		3)
11	VSS	GND (0V)	2)
12	B5	Blue Data	
13	B4		
14	B3		
15	VSS	GND (0V)	2)
16	B2	Blue Data	
17	B1		
18	B0		
19	VSS	GND (0V)	2)
20	G5	Green Data	
21	G4		
22	G3		
23	VSS	GND (0V)	2)
24	G2	Green Data	
25	G1		
26	G0		
27	VSS	GND (0V)	2)
28	R5	Red Data	
29	R4		
30	R3		
31	VSS	GND (0V)	2)
32	R2	Red Data	
33	R1		
34	R0		
35	(IC)		3)
36	VSS	GND (0V)	2)
37	VSS		
38	DCLK	Dot Clock	
39	VSS	GND (0V)	2)
40	VSS		

Notes 1) All VDD pins shall be connected to +3.3V(Typ.).

2) All VSS pins shall be grounded. Metal bezel is internally connected to VSS.

3) Keep open electrically. HITACHI test use only.

4) Unconnected to the module

8.2 BACK-LIGHT UNIT

CN2 《JST ; BHR-03VS-1》

Pin No.	Symbol	Description	Note
1	VL	Power Supply	
2	NC	Non-Connect	
3	GND	GND (0V)	

8.3 RELATIONSHIP BETWEEN DISPLAYED COLOR AND INPUT DATA

color		Red Data						Green Data						Blue Data					
		R5	R4	R3	R2	R1	R0	G5	G4	G3	G2	G1	G0	B5	B4	B3	B2	B1	B0
		MSB			LSB			MSB			LSB			MSB			LSB		
Basic Color	Black	0	0	0	0	0	0	0	0	0	0	0	0	0	0	0	0	0	0
	Red(0)	1	1	1	1	1	1	0	0	0	0	0	0	0	0	0	0	0	0
	Green(0)	0	0	0	0	0	0	1	1	1	1	1	1	0	0	0	0	0	0
	Blue(0)	0	0	0	0	0	0	0	0	0	0	0	0	1	1	1	1	1	1
	Cyan	0	0	0	0	0	0	1	1	1	1	1	1	1	1	1	1	1	1
	Magenta	1	1	1	1	1	1	0	0	0	0	0	0	1	1	1	1	1	1
	Yellow	1	1	1	1	1	1	1	1	1	1	1	1	0	0	0	0	0	0
	White	1	1	1	1	1	1	1	1	1	1	1	1	1	1	1	1	1	1
Red	Black	0	0	0	0	0	0	0	0	0	0	0	0	0	0	0	0	0	0
	Red(62)	0	0	0	0	0	1	0	0	0	0	0	0	0	0	0	0	0	0
	Red(61)	0	0	0	0	1	0	0	0	0	0	0	0	0	0	0	0	0	0
	:	:	:	:	:	:	:	:	:	:	:	:	:	:	:	:	:	:	:
	:	:	:	:	:	:	:	:	:	:	:	:	:	:	:	:	:	:	:
	Red(2)	1	1	1	1	0	1	0	0	0	0	0	0	0	0	0	0	0	0
	Red(1)	1	1	1	1	1	0	0	0	0	0	0	0	0	0	0	0	0	0
	Red(0)	1	1	1	1	1	1	0	0	0	0	0	0	0	0	0	0	0	0
Green	Black	0	0	0	0	0	0	0	0	0	0	0	0	0	0	0	0	0	0
	Green(62)	0	0	0	0	0	0	0	0	0	0	0	1	0	0	0	0	0	0
	Green(61)	0	0	0	0	0	0	0	0	0	0	1	0	0	0	0	0	0	0
	:	:	:	:	:	:	:	:	:	:	:	:	:	:	:	:	:	:	:
	:	:	:	:	:	:	:	:	:	:	:	:	:	:	:	:	:	:	:
	Green(2)	0	0	0	0	0	0	1	1	1	1	0	1	0	0	0	0	0	0
	Green(1)	0	0	0	0	0	0	1	1	1	1	1	0	0	0	0	0	0	0
	Green(0)	0	0	0	0	0	0	1	1	1	1	1	1	0	0	0	0	0	0
Blue	Black	0	0	0	0	0	0	0	0	0	0	0	0	0	0	0	0	0	0
	Blue(62)	0	0	0	0	0	0	0	0	0	0	0	0	0	0	0	0	0	1
	Blue(61)	0	0	0	0	0	0	0	0	0	0	0	0	0	0	0	0	1	0
	:	:	:	:	:	:	:	:	:	:	:	:	:	:	:	:	:	:	:
	:	:	:	:	:	:	:	:	:	:	:	:	:	:	:	:	:	:	:
	Blue(2)	0	0	0	0	0	0	0	0	0	0	0	0	1	1	1	1	0	1
	Blue(1)	0	0	0	0	0	0	0	0	0	0	0	0	1	1	1	1	1	0
	Blue(0)	0	0	0	0	0	0	0	0	0	0	0	0	1	1	1	1	1	1

Notes 1) Definition of gray scale :

Color(n)···Number in parenthesis indicates gray scale level.

Higher n corresponds to darker level.

2) Data : 1 : High, 0 : Low

9. INTERFACE TIMING

9.1 TIMING CHART

(Data : Latched at Fall edge of DCLK)

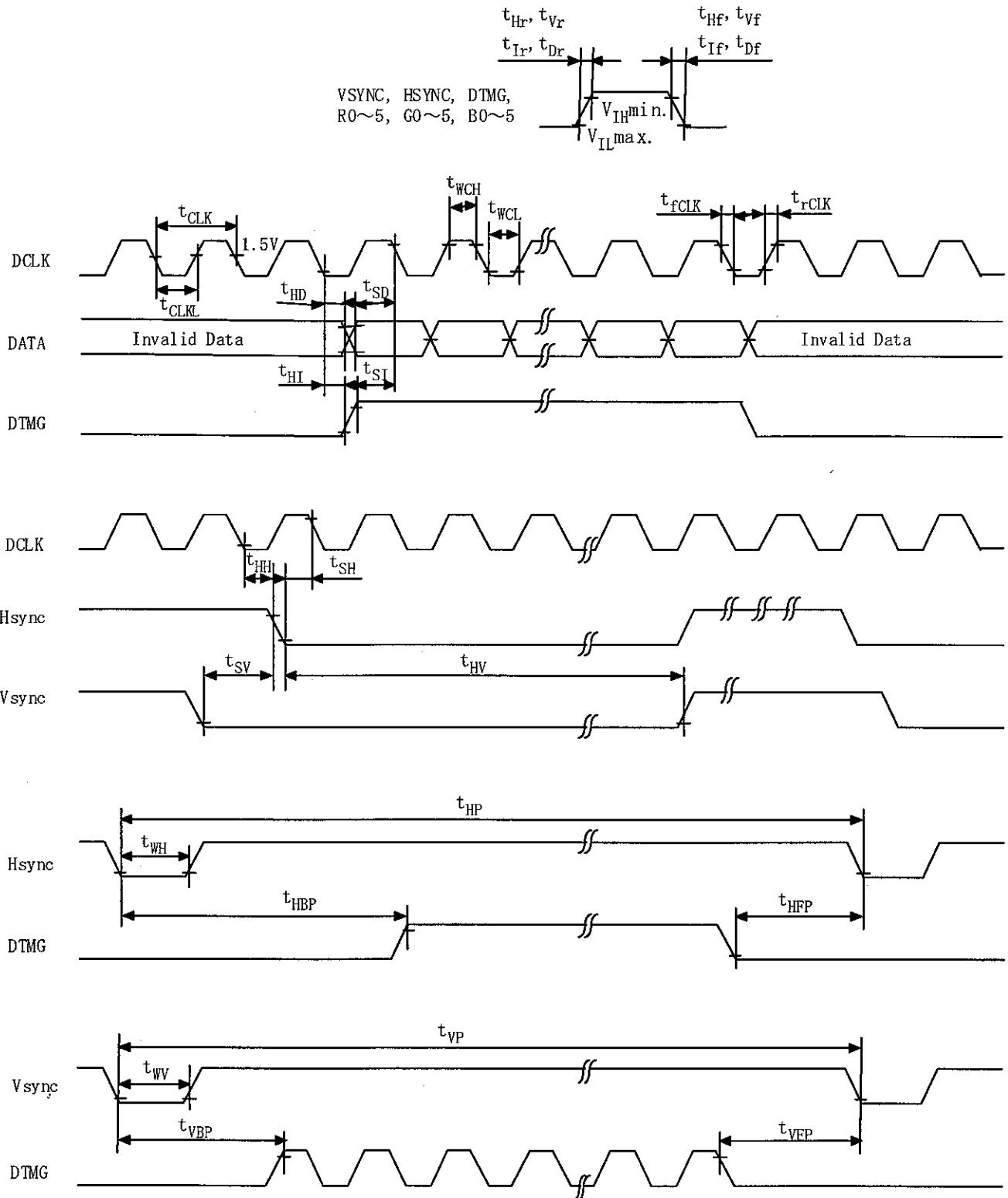

*The DTMG signal for this module is defined as above-mentioned timings for Vsync and Hsync.

This module synchronizes with only DTMG and don't require inputting Vsync and Hsync signals.

During Blanking priod , DTMG should be "Low" level

9.2 INTERFACE TIMING SPECIFICATIONS

	Item	Symbol	Min.	Typ.	Max.	Unit	Note	
DCLK	Period	t _{CLK}	25	30	33	ns		
	Width-Low	t _{WCL}	12	-	-			
	Width-Hi	t _{WCH}	12	-	-			
	Rise time	t _{rCLK}	-	-	25			
	Fall time	t _{fCLK}	-	-	25			
	Duty	D	0.45	0.5	0.55	-		D= t _{CLKL} / t _{CLK}
Hsync	Set up time	t _{SH}	5	-	-	ns	for DCLK	
	Hold time	t _{HH}	10	-	-			
	Period	t _{HP}	944	1056	1088	t _{CLK}		
	Width-Active	t _{WH}	4	128	-	ns		
	Rise/Fall time	t _{r,t_f}	-	-	30			
Vsync	Set up time	t _{SV}	0	-	-	t _{CLK}	for Hsync	
	Hold time	t _{HV}	2	-	-			
	Period	t _{VP}	515	525	610	t _{HP}		
	Width-Active	t _{WV}	1	2	-	ns		
	Rise/Fall time	t _{r,t_f}	-	-	50			
DTMG	Set up time	t _{SI}	5	-	-	ns	for DCLK	
	Hold time	t _{HI}	10	-	-			
	Rise/Fall time	t _{r,t_f}	-	-	30	ns		
	Horizontal Back porch	t _{HBP}	7	216	-			t _{CLK}
	Horizontal Front porch	t _{HFP}	-	40	-			
	Vertical Back porch	t _{VBP}	4	34	-	t _{HP}		
	Vertical Front porch	t _{VFP}	-	11	-			
Data	Set up time	t _{SD}	5	-	-	ns		for DCLK
	Hold time	t _{HD}	10	-	-			
	Rise/Fall time	t _{Dr,t_{Df}}	-	-	25	ns		

9.3 TIMING BETWEEN INTERFACE SIGNAL AND POWER SUPPLY

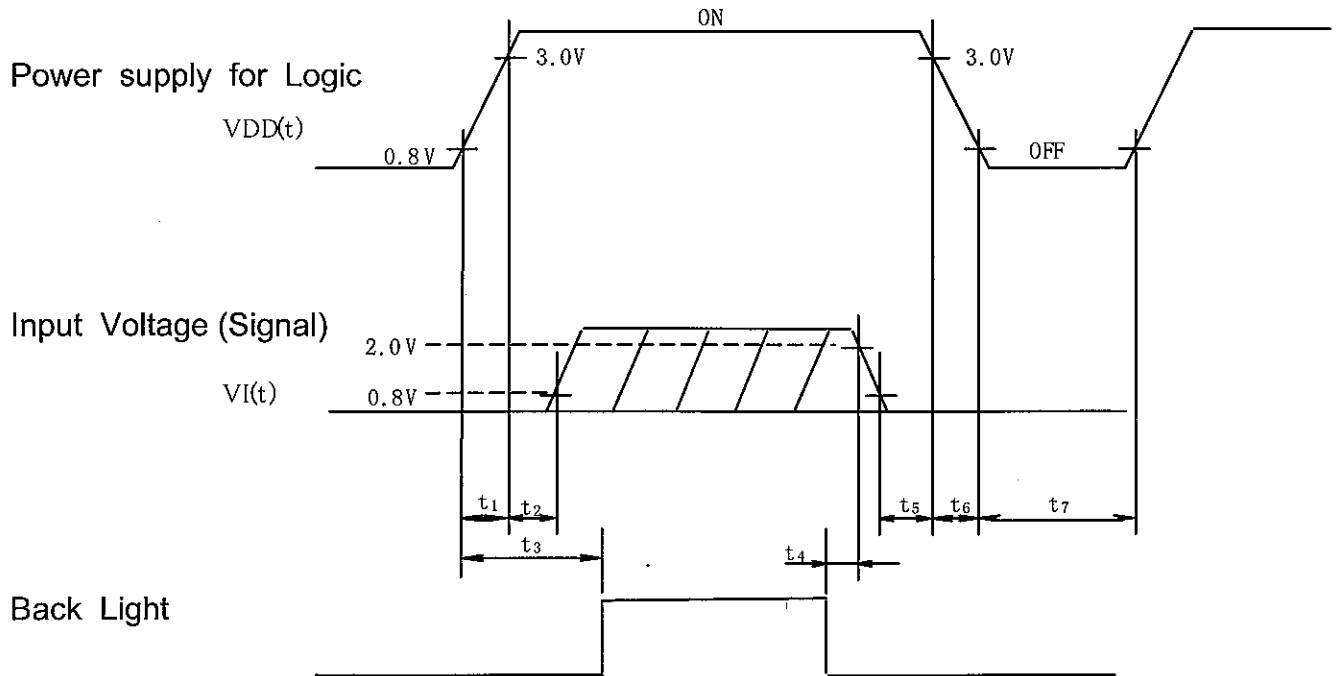

POWER ON

$$t_1 \leq 15\text{ms}$$

$$0\text{ms} < t_2 \leq 45\text{ms}$$

$$0.1\text{s} \leq t_3$$

POWER OFF

$$5\text{ms} \leq t_4$$

$$0\text{ms} \leq t_5 \leq 45\text{ms}$$

$$0\text{ms} \leq t_6 \leq 20\text{ms}$$

$$0.4\text{s} \leq t_7$$

Note 1) Set $0\text{V} \leq VI(t) \leq VDD(t)$.

Here, $VI(t)$, $VDD(t)$ indicate the transitional state of VI , VDD when power supply is turned ON or OFF.

2) Do not keep interface signal high-impedance when power on.

10. DIMENSIONAL OUTLINE

10.1 SURFACE SIDE

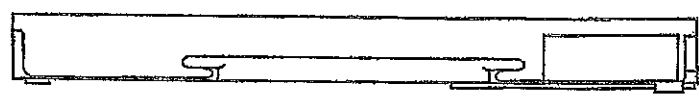
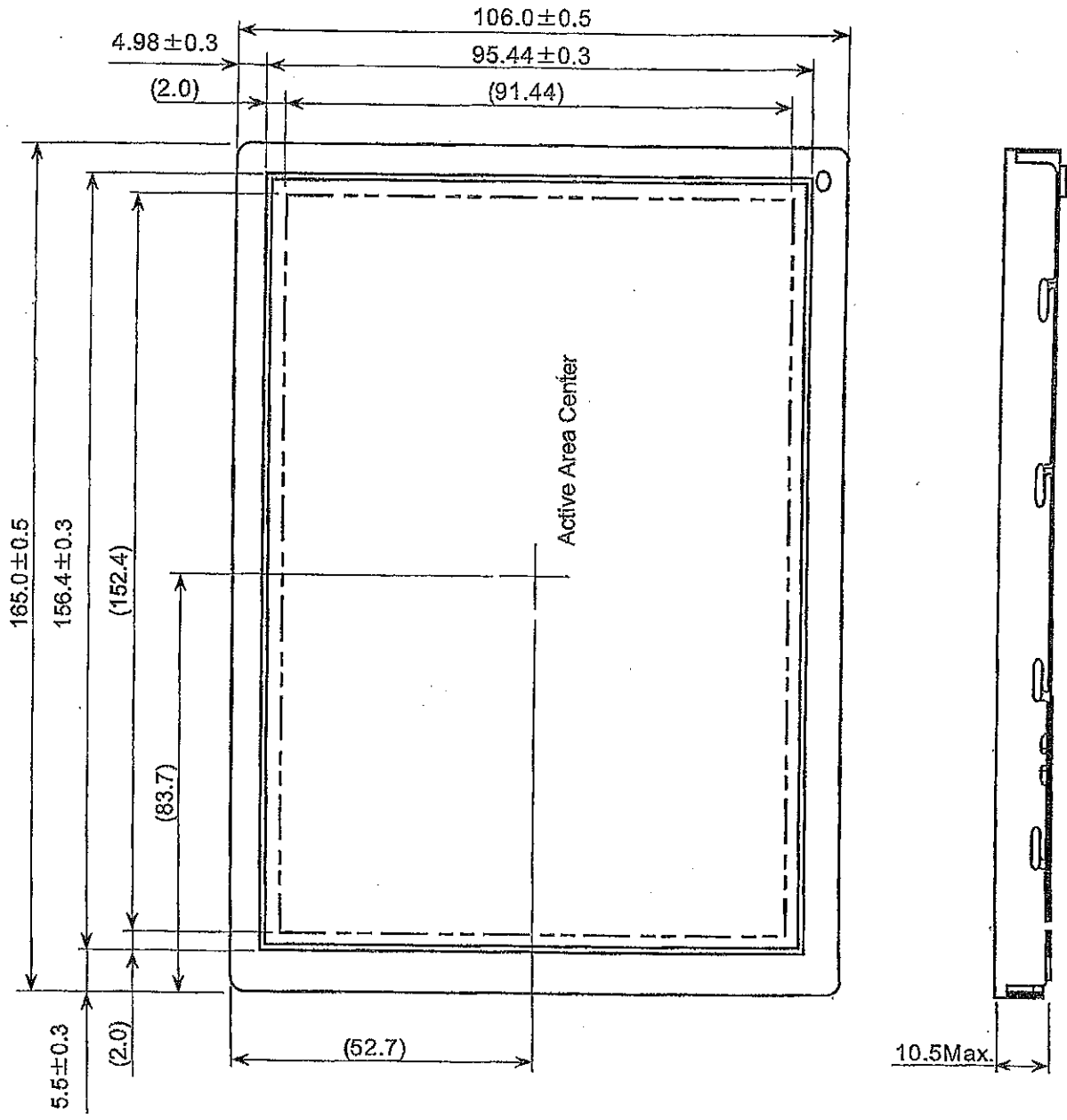

Unit : mm

10.2 BACK SIDE

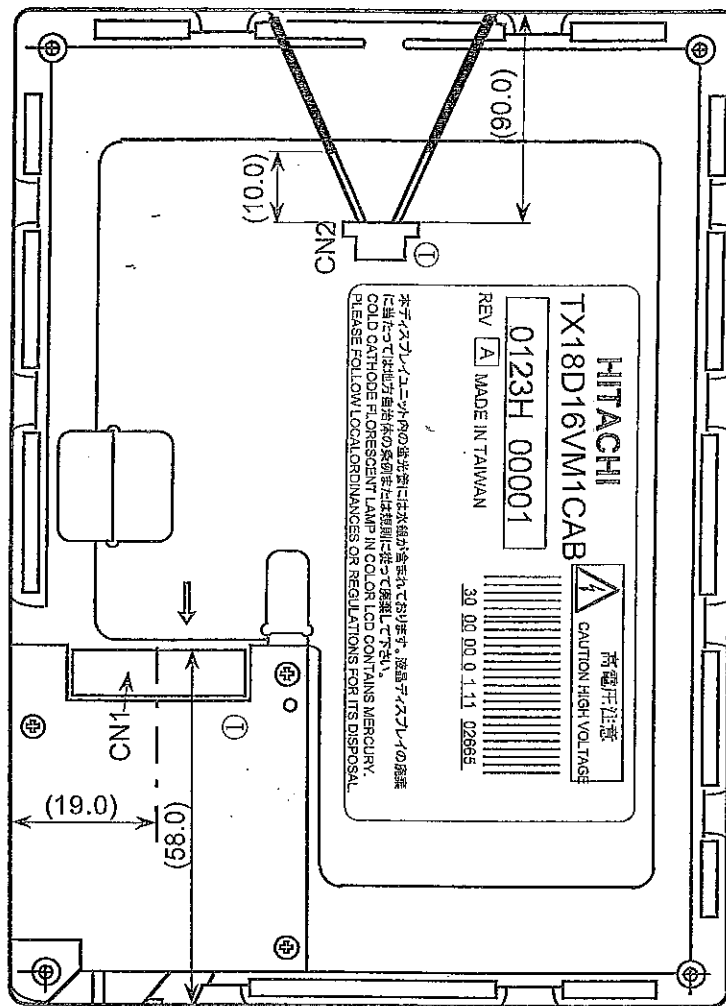

Unit : mm

- Note 1) CN1 : FA5B040HF 1R3000(JAE)
 2) CN2 : BHR-03VS-1(JST)

11. DESIGNATION OF LOT MARK

11.1 LOT MARK

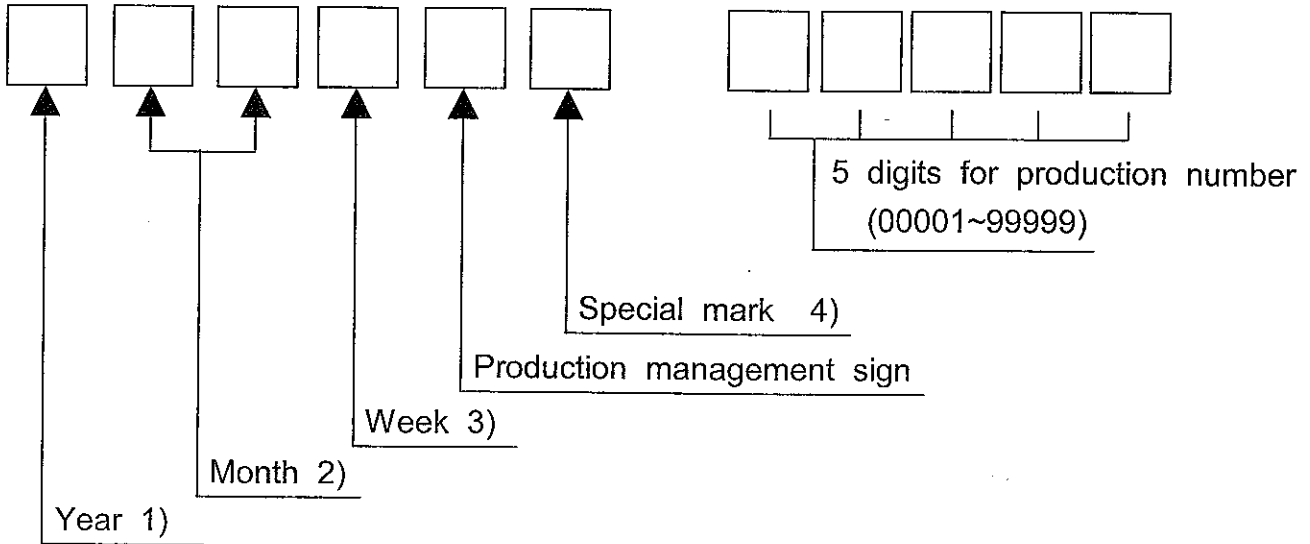

Notes

1)

Year	Mark
2005	5
2006	6
2007	7
2008	8
2009	9

2)

Month	Mark	Month	Mark
1	01	7	07
2	02	8	08
3	03	9	09
4	04	10	10
5	05	11	11
6	06	12	12

3)

Week (Days)	Mark
1~7	1
8~14	2
15~21	3
22~28	4
29~31	5

4) The special mark may be added by manufacturing accordingly to production number.

11.2 REVISION(REV.) CONTROL

REV. column is controlled by the manufacturing. A-Z except I and O is to be written on this column

11.3 LOCATION OF LOT MARK

Lot mark is printed on a label. The label is on rear side of module as shown in the drawing at Section 10.

The style of character may be changed without notice.

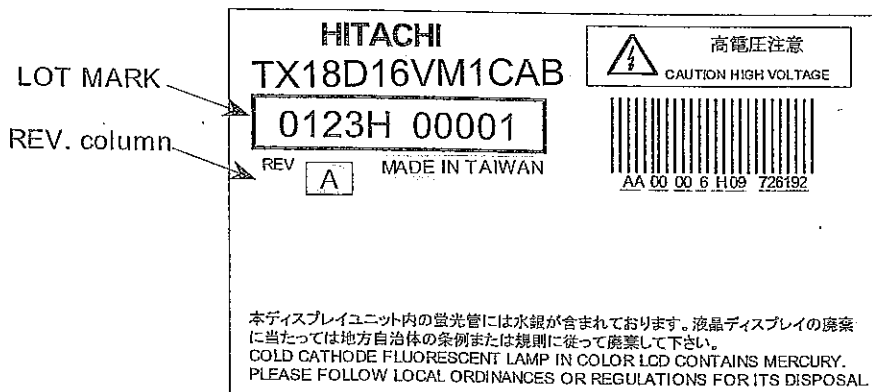

12. COSMETIC SPECIFICATIONS

12.1 CONDITION FOR COSMETIC INSPECTION

(1) Viewing zone

a) The figure shows the correspondence between eyes (of inspector) and TFT-LCD module.

$\theta \leq 45^\circ$: when non-operating inspection

$\theta \leq 5^\circ$: when operating inspection

b) Inspection should be executed only from front side and only A-zone.

Cosmetic of B-zone and C-zone are ignored.
(refer to 9.2 Definition of zone)

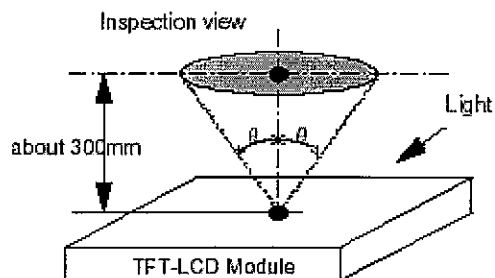

(2) Environmental

a) Temperature : 25°C

The appearance inspection at Back-light on is done at 25°C on a TFT-LCD panel.

b) Ambient light : More than 2000 [lx] and non-directive.

c) Back-light : when non-operating inspection , Back-light should be off.

(3) Operating inspection

Operating inspection should be done with 8 color mode (without gray scale).

12.2 DEFINITION OF ZONE

A-zone : Display area (pixel area)

B-zone : Area between A-zone and C-zone

C-zone : Metallic bezel area (include I/F connector)

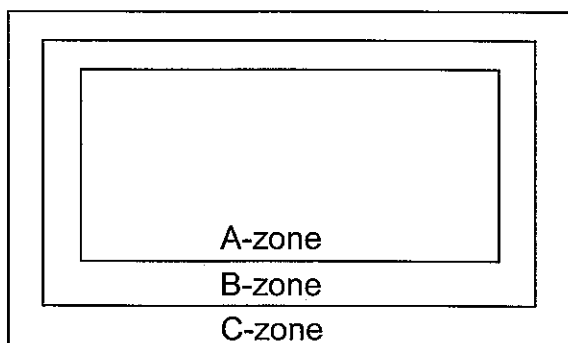

12.3 COSMETIC SPECIFICATIONS

When displaying conditions are not stable (ex. at turn on or off), the following specifications are not applied.

No	ITEM			Max. acceptable number	Unit	Note
				A-zone		
1	Dot defect	Sparkle mode	1-dot	4	pcs	1),2),4)
			2-dots	1	Units	1),2),5)
			3-dots	0		
			4-dots	0		
			Density	2		
			Total	5	pcs	1),2)
		Black mode	1-dot	5	pcs	1),3),4)
			2-dots	2	Units	1),3),5)
			3-dots	0		
			4-dots	0		
	Density		3	pcs/φ20mm	1),3),6)	
	Total	5	pcs	1),3)		
	Total			10	pcs	1)
	2	Line defect			Serious one is not allowed	
3	Uneven brightness					
4	Stains, Foreign Materials Line shape W : width (mm) L : length (mm)	W ≤ 0.02	L : Ignore	Ignore	pcs	7)
		W ≤ 0.03	L ≤ 2.0	10		
			L > 2.0	0		
		W ≤ 0.06	L ≤ 1.0	10		
			L > 1.0	0		
W > 0.06	-	(See dot shape)				
5	Stains, Foreign Materials Dot shape D : ave. dia (mm)	D ≤ 0.22		Ignore	pcs	7)
		D ≤ 0.33		5		
		D > 0.33		0		
6	Scratch on polarizer Line shape W : width (mm) L : length (mm)	W ≤ 0.01	L : Ignore	Ignore	pcs	8)
		W ≤ 0.02	L ≤ 40	10		
			L > 40	0		
		W ≤ 0.04	L ≤ 20	10		
			L > 20	0		
7	Scratch on polarizer Dot shape D : ave. dia (mm)	D ≤ 0.2		Ignore	pcs	8)
		D ≤ 0.4		10		
		D > 0.4		0		

No	ITEM		Max. acceptable number	Unit	Note
			A-zone		
8	Bubbles, peeling In polarizer [D:ave.dia(mm)]	$D \leq 0.3$	Ignore	pcs	8)
		$D \leq 0.5$	10		
		$D \leq 1.0$	5		
		$D > 1.0$	0		
9	Wrinkles on polarizer		Serious one is not allowed	-	-

Note 1) Dot defect : defect area > 1/2 dot

2) Sparkle mode : brightness of dot is more than 30% at black raster. (visible to eye)

3) Black mode : brightness of dot is less than 70% at white raster. (visible to eye)

4) 1 dot : defect dot is isolated, not attached to other defect dot.

5) N dots : N defect dots are consecutive. (N means the number of defects dots)

6) Density : number of defect dots inside 20mm ϕ .

7) Those stains which can be wiped out easily are not defects.

8) Polarizer area inside of B-zone is not applied.

13. PRECAUTION

1. Please pay attention to the followings when you use this TFT-LCD Module with Back-light unit.

2. LIFT SUPPORT APPLICATIONS : Hitachi's products are not authorized for use in LIFT UPPOINT SYSTEMS.

13.1 PRECAUTION TO HANDLING AND MOUNTING

- (1) You should consider the mounting structure so that uneven force (ex. twisted stress) is not applied to the module.
- (2) To improve the strength of module against the mechanical shock the space between the module and the case should be less than 1.0mm.
- (3) Protection material in front of LCD's screen surface is recommended to protect a polarizer, LCD-glass and metal bezel. Please be note that the protection material should not touch them directly.
- (4) Acetic acid type and choline type materials for the cover case are not desirable because the former generate corrosive gas of attacking the polarizer at high temperature and the latter causes circuit break by electro-chemical reaction.
- (5) Do not touch, push or rub the exposed polarizers with glass, tweezers or anything harder than HB pencil lead. And please do not rub by dustclothes with chemical treatment. Do not touch the surface of polarizer with bare hand or greasy close. (Some cosmetics are detrimental to the polarizer.)
- (6) When the surface becomes dusty, please wipe gently with absorbent cotton or other soft materials chamois soaked Normal-Hexane. Normal-Hexane is recommended for cleaning the adhesives used to attach front/rear polarizers. Do not use acetone, toluene and alcohol because they cause chemical damage to the polarizer.
- (7) Wipe off saliva or water drops as soon as possible. Their long time contact with polarizer causes deformations and color fading.
- (8) The module should never be opened or modified. It may cause not to operate properly.
- (9) Metallic bezel of a module should not be handled with bare hand or dirty gloves. Otherwise, color of a metallic frame may become dirty during its storage. It is recommended to use clean soft gloves and clean finger stalls when a module is handled at incoming inspection process and production (assembly) process.
- (10) When you adopt a metallic shield board on backside of TFT-LCD Module, it should not be too close to TFT-LCD Module.
- (11) Do not pull or do not fold the CCFL cable.

13.2 PRECAUTION TO OPERATION

- (1) You should adopt radiation structure to satisfy the temperature specification.
- (2) Optical response time, luminance and chromaticity depend on the temperature of a TFT-LCD module. (At lower temperature it becomes longer.)
- (3) Response time and saturation time of CCFL luminance become longer at lower temperature operation.
- (4) Sudden temperature change may cause dew on and/or in the a module.
Dew males damage to a polarizer and/or electrical contacting portion.
Dew causes fading of displayed quality.
- (5) Fixed patterns displayed on a module for a long time may cause after-image.
It will be recovered soon.
- (6) Please connect the Back-light connector to the inverter circuit directly.
The long cable between CCFL and the inverter may cause the brightness drop of CCFL and may cause the rise of starting lamp voltage(Vs).
- (7) The module should not be connected or removed while a main system works.
- (8) Inserting or pulling I/F connectors causes any truble when power supply and signal datas are on-state. I/F connectors should be inserted and pulled after power supply and signal datas are turned off.

13.3 ELECTROSTATIC DISCHARGE CONTROL

- (1) Since a module consists of a TFT cell and electronic circuits with CMOS-ICs, which are very weak to electrostatic discharge, persons who are handling a module should be grounded through adequate methods such as a list band.
I/F connector pins should not be touched directly with bare hands.
- (2) Protection film for a polarizer on a module should be slowly peeled off so that the electrostatic charge can be minimized.

13.4 PRECAUTION TO STRONG LIGHT EXPOSURE

A module should not be exposed under strong light. Otherwise, characteristics of a polarizer and color filter in a module may be degraded.

13.5 PRECAUTION TO STORAGE

When TFT-LCD Modules are stored for long time, following precautions should be taken care of:

- (1) Modules should be stored in a dark place. It is prohibited to apply sunlight or fluorescent light during storage. Modules should be stored at 0 to 35°C at normal humidity (60%RH or less).
- (2) The surface of polarizers should not come in contact with any other object. It is recommended that modules should be stored in the HITACHI's shipping box.

13.6 PRECAUTION TO HANDLE PROTECTIVE FILM

- (1) When the protective film is peeled off, static electricity is generated between the film and the polarizer. This film should be peeled off slowly and carefully by people who are electrically grounded and with well ion-blown equipment or in such a condition, etc.
- (2) The protective film is attached to the polarizer with a small amount of glue. If some stress is applied to rub the protective film against the polarizer during the time you peel off the film, the glue is apt to remain more on the polarizer. So please carefully peel off the protective film without rubbing it against the polarizer.
- (3) When the module with protective film attached is stored for long time, sometimes there remains a very small amount of glue, still on the polarizer after the protective film is peeled off. Please refrain from storing the module at the module at the high temperature and high humidity for glue is apt to remain in these condition.
- (4) The glue may be taken for the modules failure, but you can remove the glue easily. When the glue remains on the polarizer surface or its vestige is recognized, please wipe them off with absorbent cotton waste or other soft material like chamois soaked with Norm-Hexane.

13.7 SAFETY

- (1) If module is broken, be careful to handle not to injure.
(TFT-LCD and Lamp are made of glass.)
Please wash hands sufficiently when you touch the liquid crystal coming out from broken LCDs.
- (2) As Back-light unit has high voltage circuit internal, do not open the case and do not insert foreign materials in the case.
- (3) The CCFL inverter should be designed to include the function of output shutdown in case the output overcurrent happen due to any backlight trouble.
The shutdown function should be assured to work in abnormal condition at the actual systems.

13.8 ENVIROMENTAL PROTECTION

- (1) This TFT-LCD Module include Cold Cathode Fluorescent Lamp (CCFL). CCFL contains a small amount of mercury. Please follow local ordinance or regulations for disposal.
- (2) Flexible circuits board, printed circuits board and solder used in a module contain small amount of lead (Pb). Please follow local ordinance or regulations for its disposal.

10.9 USE RESTRICTIONS AND LIMTATIONS

- (1) This product is not authorized for use in life support devices or systems, military applications or other applications which pose a significant risk of personal injury.
- (2) In no event shall HITACHI, Ltd. , be liable for any incidental, indirect or consequential damages in connection with the installation or use of this product, even if informed of the possibility thereof in advance. These limitations apply to all causes of action in the aggregate, including without limitation breach of contract, breach of warranty, negligence, strict liability, misrepresentation and other torts.

13.10 OTHERS

- (1) Electrical components which may not affect electrical performance are subjective to change without notice because of their availability.