

mass integrated

global part distribution • product lifecycle partner
excess inventory management • value-ad service provider



Data sheet provided by Mass Integrated

massintegrated.com • displayalliance.com

Please call +1.978.465.6190
Email: sales@massintegrated.com



ISO 9001: 2008

Mass Integrated complies with all DMCA takedown notices. Please send a formal DMCA Takedown Notice to Mass Integrated Systems, Inc. • 18 Henry Graf Jr. Road, Unit 1 • Newburyport, MA 01950.

HITACHI

KAOHSIUNG HITACHI ELECTRONICS CO., LTD.

DATE: May. 15th 2009

CUSTOMER'S ACCEPTANCE SPECIFICATIONS

TX26D12VM0AAA

Contents

No.	ITEM	SHEET No.	PAGE
1	COVER	7B64PS 2701-TX26D12VM0AAA-1	1-1/1
2	RECORD OF REVISION	7B64PS 2702-TX26D12VM0AAA-1	2-1/1
3	GENERAL DATA	7B64PS 2703-TX26D12VM0AAA-1	3-1/1
4	ABSOLUTE MAXIMUM RATINGS	7B64PS 2704-TX26D12VM0AAA-1	4-1/1
5	ELECTRICAL CHARACTERISTICS	7B64PS 2705-TX26D12VM0AAA-1	5-1/2~2/2
6	OPTICAL CHARACTERISTICS	7B64PS 2706-TX26D12VM0AAA-1	6-1/2~2/2
7	BLOCK DIAGRAM	7B64PS 2707-TX26D12VM0AAA-1	7-1/1
8	RELIABILITY TESTS	7B64PS 2708-TX26D12VM0AAA-1	8-1/1
9	LCD INTERFACE	7B64PS 2709-TX26D12VM0AAA-1	9-1/11~11/11
10	OUTLINE DIMENSIONS	7B63PS 2710-TX26D12VM0AAA-1	10-1/2~2/2
11	APPEARANCE STANDARD	7B64PS 2711-TX26D12VM0AAA-1	11-1/3~3/3
12	PRECAUTIONS	7B64PS 2712-TX26D12VM0AAA-1	12-1/2~2/2
13	DESIGNATION OF LOT MARK	7B64PS 2713-TX26D12VM0AAA-1	13-1/1

ACCEPTED BY: _____

PROPOSED BY: 

2. RECORD OF REVISION

DATE	SHEET No.	SUMMARY

3. GENERAL DATA

3.1 DISPLAY FEATURES

This module is a 10.4" SVGA of 4:3 format amorphous silicon TFT. The pixel format is vertical stripe and sub pixels are arranged as R(red), G(green), B(blue) sequentially. This display is RoHS compliant, and COG (chip on glass) technology and LED backlight are applied on this display.

Part Name	TX26D12VM0AAA
Module Dimensions	243.0(W) mm x 185.1(H) mm x 11.0max (D) mm
LCD Active Area	211.2(W) mm x 158.4(H) mm
Dot Pitch	0.088(W) mm x 3(R, G, B)(W) x 0.264(H) mm
Resolution	800 x 3(RGB)(W) x 600(H) dots
Color Pixel Arrangement	R, G, B Vertical stripe
LCD Type	Transmissive Color TFT; Normally Black
Display Type	Active Matrix
Number of Colors	16777k Colors(8-bit RGB)
Backlight	8 LEDs parallel x 3 serial (24 LEDs in total)
Weight	(560) g (typ.)
Interface	1ch-LVDS/Receiver ; 20 pins
Power Supply Voltage	3.3V for LCD; 12V for Backlight
Power Consumption	1.221 W for LCD (SVGA) ;7.68W for backlight
Viewing Direction	Super Wide Version (Horizontal and Vertical: 170°, CR ≥ 10)

4. ABSOLUTE MAXIMUM RATINGS

Item	Symbol	Min.	Max.	Unit	Remarks	
Supply Voltage	VDD	0	4.0	V	-	
Input Voltage of Logic	VI	-0.3	VDD+0.3	V	Note 1	
Operating Temperature	Top	-20	70	°C	Note 2	
Storage Temperature	Tst	-30	80	°C	Note 2	
LED Unit	Forward Current	IF	-	120	mA	Note 3
	Reverse Voltage	VR	-	3.65	V	

Note 1: It shall be applied to pixel data signal and clock signal.

Note 2: The maximum rating is defined as above based on the temperature on the panel surface, which might be different from ambient temperature after assembling the panel into the application. Moreover, some temperature-related phenomenon as below needed to be noticed:

- Background color, contrast and response time would be different in temperatures other than 25°C.
- Operating under high temperature will shorten LED lifetime.

Note 3: Fig. 4.1 shows the maximum rating of LED forward current against temperature. The backlight unit in this display has been set to 80 mA per LED. This is within the range when operating the display between -20~70°C.

For the dimming function, reducing the LED backlight voltage 12V to the expected brightness is recommended. Alternatively, using PWM signal with 10KHz and 3.3V amplitude to dim by adjusting the duty ratio.

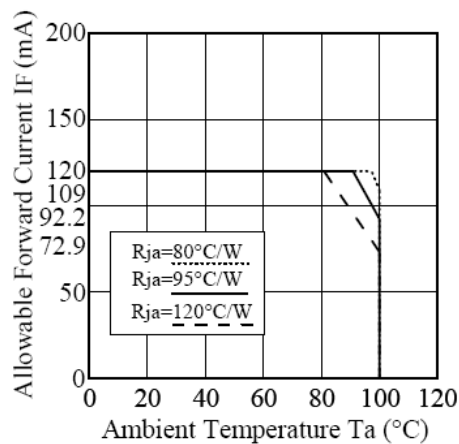

Fig. 4.1

5. ELECTRICAL CHARACTERISTICS

5.1 LCD CHARACTERISTICS

$T_a = 25\text{ }^\circ\text{C}$, $V_{SS} = 0\text{V}$

Item	Symbol	Condition	Min.	Typ.	Max.	Unit	Remarks
Power Supply Voltage	VDD	-	3.0	3.3	3.6	V	-
Differential Input Voltage for LVDS Receiver Threshold	VI	"H" level	-	-	+100	mV	Note 1
		"L" level	-100	-	-		
DPS,FRC,AMODE Signal Input Voltage	VI	"H" level	0.7VDD	-	VDD	V	CMOS LEVEL
		"L" level	0	-	0.3VDD		
Power Supply Current	IDD	VDD-VSS =3.3V	-	370	550	mA	Note 2,3
Vsync Frequency	f_v	-	-	60	75	Hz	Note 4,5
Hsync Frequency	f_H	-	-	37.7	50.6	KHz	Note 4
DCLK Frequency	f_{CLK}	-	-	40	43	MHz	Note 4

Notes 1 : $V_{CM} = V_{DD} / 2V$

V_{CM} is common mode voltage of LVDS transmitter / receiver. The input terminal of LVDS transmitter is terminated with 100Ω .

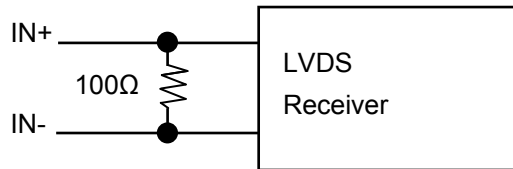

Notes 2 : $f_v = 60\text{Hz}$, $f_{CLK} = 40\text{MHz}$, $V_{DD} = 3.3\text{V}$, DC Current.

Typical value is measured when displaying vertical 256 gray scale. Maximum is measured when displaying Vertical-stripe.

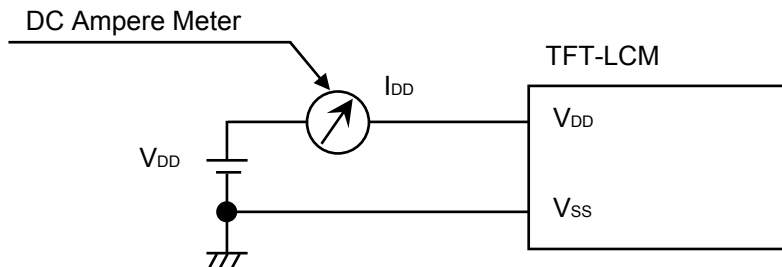

Notes 3 : As this module contains 0.8A fuse, prepare current source that is enough for cutting current fuse when a trouble happens. (larger than 2.0A)

Notes 4 : For LVDS Transmitter Input

Notes 5 : Vertical Frequency is encouraged to be used by 60Hz. The flicker level changes by the gap of the vertical frequency.

5.2 BACKLIGHT CHARACTERISTICS

Item	Symbol	Condition	Min.	Typ.	Max.	Unit	Remarks
LED Input Voltage	VLED	-	11.7	12.0	12.3	V	Note1
LED Forward Current (Dim Control)	ILED	0V; 0% duty	-	(660)	-	mA	Note 2
		3.3VDC; 100% duty	-	(30)	-		
LED lifetime	-	640 mA	-	70K	-	hrs	Note 3

Note 1: As Fig. 5.1 shown, LED current is constant, 640 mA, controlled by the LED driver when applying 12V VLED.

Note 2: Dimming function can be obtained by applying DC voltage or PWM signal from the display interface CN1. The recommended PWM signal is 1K ~ 10K Hz with 3.3V amplitude.

Note 3: The estimated lifetime is specified as the time to reduce 50% brightness by applying 640 mA at 25°C.

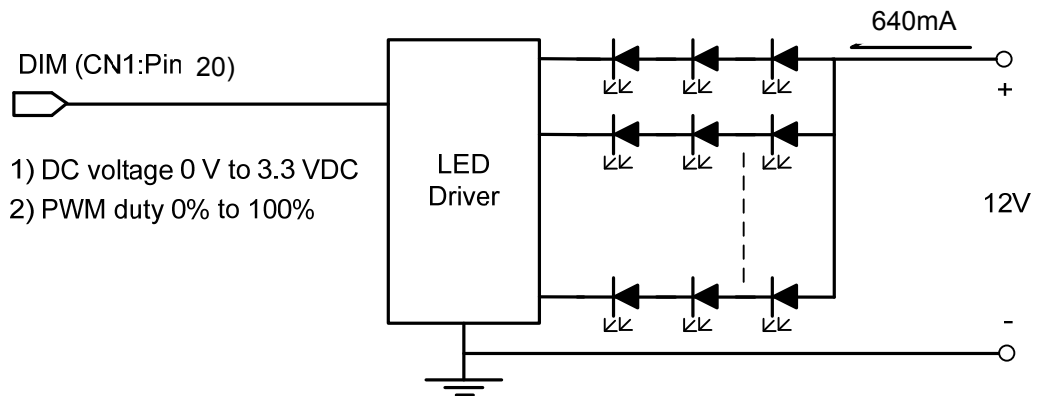

Fig. 5.1

6. OPTICAL CHARACTERISTICS

The optical characteristics are measured based on the conditions as below:

- Supplying the signals and voltages defined in the section of electrical characteristics.
- The backlight unit needs to be turned on for 30 minutes.
- The ambient temperature is 25°C.
- In the dark room around 500~1000 lx, the equipment has been set for the measurements as shown in Fig 6.1.

$$T_a = 25^\circ\text{C}, f_v = 60\text{Hz}, V_{DD} = 3.3\text{V}$$

Item	Symbol	Condition	Min.	Typ.	Max.	Unit	Remarks
Brightness of White	-	$\phi = 0^\circ, \theta = 0^\circ,$ ILED= 640 mA	350	450	-	cd/m ²	Note 1
Brightness Uniformity	-		75	-	-	%	Note 2
Contrast Ratio	CR		500	800	-	-	Note 3
Response Time	Rise + Fall	$\phi = 0^\circ, \theta = 0^\circ$	-	25	65	ms	Note 4
NTSC Ratio	-	$\phi = 0^\circ, \theta = 0^\circ$	-	60	-	%	-
Viewing Angle	θ_x	$\phi = 0^\circ, CR \geq 10$	-	85	-	Degree	Note 5
	$\theta_{x'}$	$\phi = 180^\circ, CR \geq 10$	-	85	-		
	θ_y	$\phi = 90^\circ, CR \geq 10$	-	85	-		
	$\theta_{y'}$	$\phi = 270^\circ, CR \geq 10$	-	85	-		
Color Chromaticity	Red	X	(0.57)	(0.61)	(0.67)	-	Note 6
		Y	(0.27)	(0.36)	(0.37)		
	Green	X	(0.25)	(0.37)	(0.35)		
		Y	(0.54)	(0.59)	(0.64)		
	Blue	X	(0.09)	(0.15)	(0.19)		
		Y	(0.05)	(0.10)	(0.15)		
	White	X	(0.30)	(0.35)	(0.40)		
		Y	(0.32)	(0.37)	(0.42)		

Note 1: The brightness is measured from 9 point of the panel, P1~P9 in Fig. 6.2, for the average value.

Note 2: The brightness uniformity is calculated by the equation as below:

$$\text{Brightness uniformity} = \frac{\text{Min. Brightness}}{\text{Max. Brightness}} \times 100\%$$

, which is based on the brightness values of the 9 points measured by BM-5 as shown in Fig. 6.2.

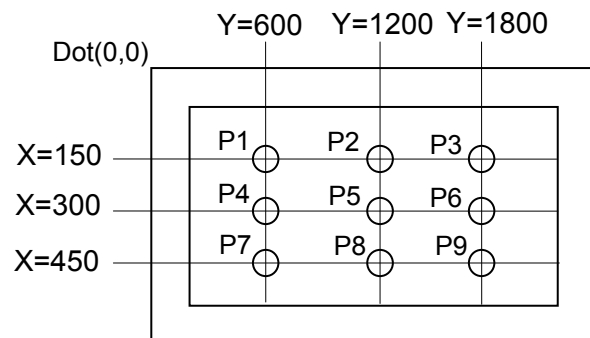
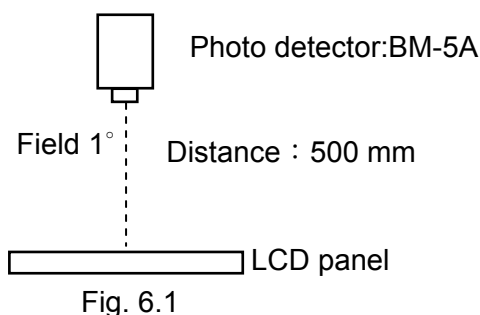

Note 3: The Contrast ratio is measured from the center point of the panel, P5, and defined as the following equation:

$$CR = \frac{\text{Brightness of White}}{\text{Brightness of Black}} \times 100\%$$

Note 4: The definition of response time is shown in Fig. 6.3. The rising time is the period from 10% brightness to 90% brightness when the data is from white to black. Oppositely, Falling time is the period from 90% brightness rising to 10% brightness.

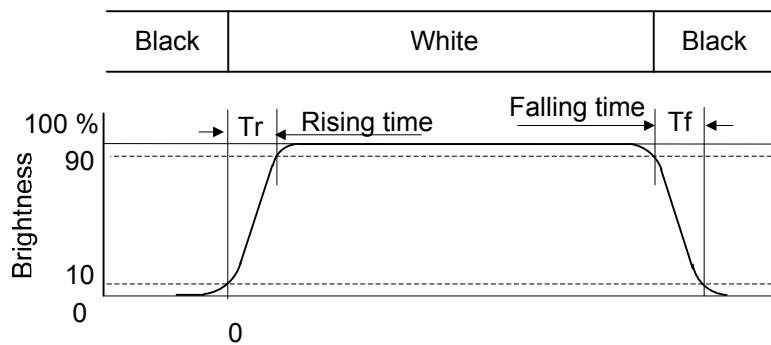

Fig . 6.3

Note 5: The definition of viewing angle is shown in Fig. 6.4. Angle ϕ is used to represent viewing directions, for instance, $\phi = 270^\circ$ means 6 o'clock, and $\phi = 0^\circ$ means 3 o'clock. Moreover, angle θ is used to represent viewing angles from axis Z toward plane XY.

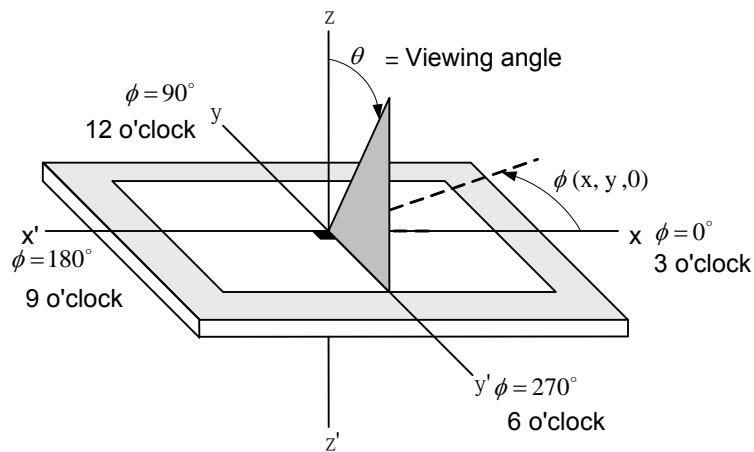
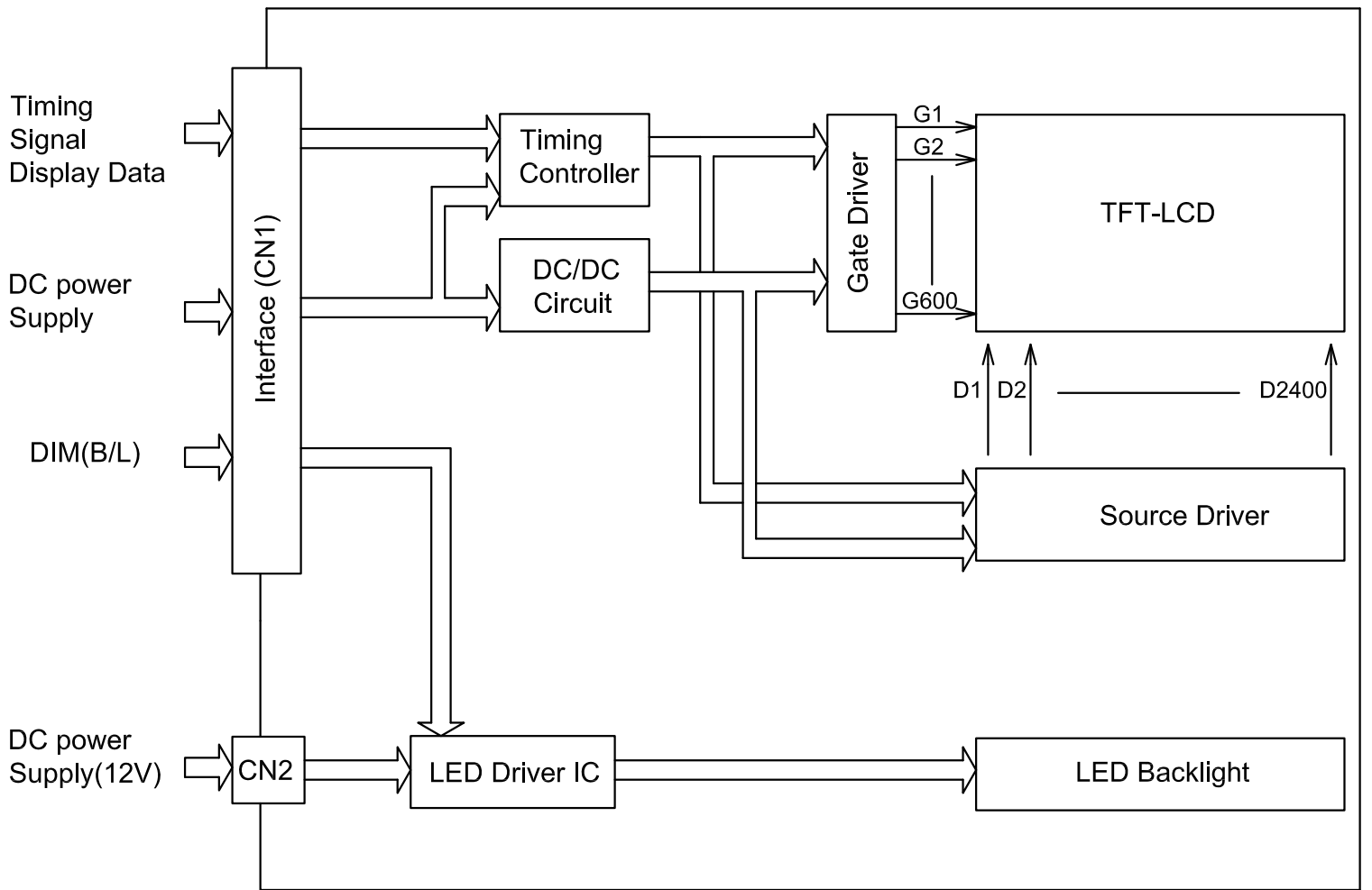

Fig. 6.4

Note 6: The color chromaticity is measured from the center point of the panel, P5, as shown in Fig. 6.2.

7 BLOCK DIAGRAM



8. RELIABILITY TESTS

Test Item	Condition	
High Temperature	1) Operating 2) 70 °C	240 hrs
Low Temperature	1) Operating 2) -20 °C	240 hrs
High Temperature	1) Storage 2) 80 °C	240 hrs
Low Temperature	1) Storage 2) -30 °C	240 hrs
Heat Cycle	1) Operating 2) -20 °C ~70 °C 3) 3hrs~1hr~3hrs	240 hrs
Thermal Shock	1) Non-Operating 2) -35 °C ↔ 85 °C 3) 0.5 hr ↔ 0.5 hr	240 hrs
High Temperature & Humidity	1) Operating 2) 40 °C & 85%RH 3) Without condensation 4) Note 3	240 hrs
Vibration	1) Non-Operating 2) 20~200 Hz 3) 2G 4) X, Y, and Z directions	1 hr for each direction
Mechanical Shock	1) Non-Operating 2) 10 ms 3) 50G 4) ±X, ±Y and ±Z directions	Once for each direction
ESD	1) Operating 2) Tip: 200 pF, 250 Ω 3) Air discharge for glass: ± 8KV 4) Contact discharge for metal frame: ± 8KV 5) Contact discharge for LCD interface: ± 100V	1) Glass: 9 points 2) Metal frame: 8 points 3) Connector: all pins

Note 1: Display functionalities are inspected under the conditions defined in the specification after the reliability tests.

Note 2: The display is not guaranteed for use in corrosive gas environments.

Note 3: Under the condition of high temperature & humidity, if the temperature is higher than 40°C, the humidity needs to be reduced as Fig. 7.1 shown.

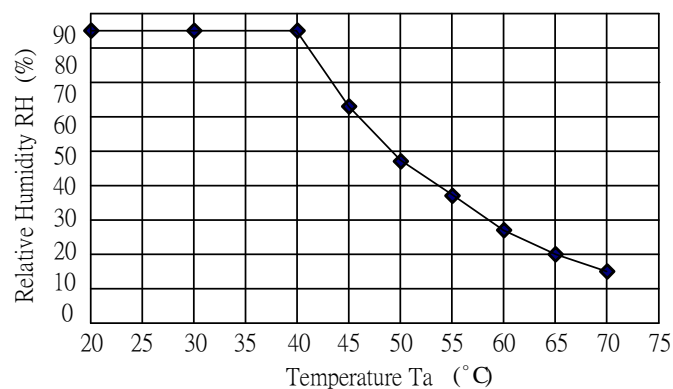

Fig. 7.1

9. LCD INTERFACE

9.1 INTERFACE PIN CONNECTIONS

The display interface connector is FI-SEB20P-HF13E made by JAE and more details of the connector are shown in the section of outline dimension.

Pin assignment of LCD interface is as below:

Pin No.	Symbol	Description	Note
1	VDD	Power Supply for Logic	1)
2	VDD		
3	DPS	Scan Direction Control (High : Reverse , Low : STD)	3)
4	VSS	Ground (0V)	2)
5	IN0-	Pixel Data	
6	IN0+		
7	VSS	Ground (0V)	2)
8	IN1-	Pixel Data	
9	IN1+		
10	VSS	Ground (0V)	2)
11	IN2-	Pixel Data	
12	IN2+		
13	VSS	Ground (0V)	2)
14	CLK IN-	Clock	
15	CLK IN+		
16	FRC	High : 8bit , Low : 6bit	
17	IN3-	Pixel Data	
18	IN3+		
19	AMODE	LVDS Format Setting (Refer to P9-2/11)	
20	DIM	Normal Brightness:0V or 0% PWM Duty Brightness Control:0V to 3.3VDC or 0% to 100% PWM Duty.	

Note 1) All VDD pins should be connected to +3.3V.

Note 2) All VSS pins should be connected to GND(0V),Metal bezel is connected internally to VSS.

Note3) Vertical Display Inode and Horizontal Display mode control



The backlight interface connector is SM08B-SRSS-TB made by JST, and pin assignment of backlight is as below:

Pin No.	Signal	Level	Function
1~3	V _{LED+}	-	Power Supply for LED(12V)
4~5	NC	-	No Connection
6~8	V _{LED-}	-	GND

9.2 LVDS INTERFACE

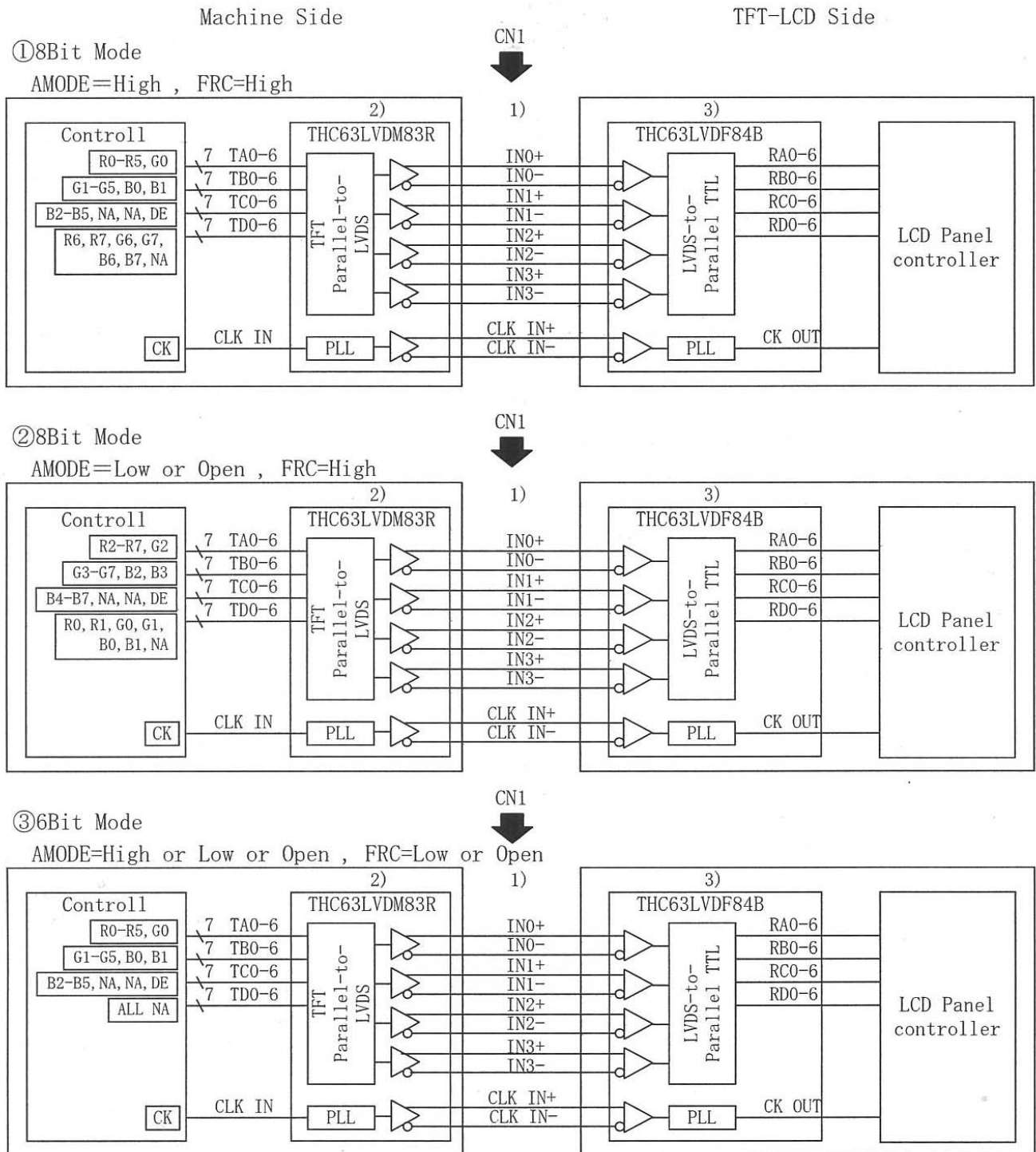

Note 1) LVDS cable impedance should be 100 ohms per signal line when each 2-lines(+,-) is used in differential mode.

Note 2) Transmitter Made by Thine : THC63LVDM83R equivalent.
 Transmitter is not contained in Module.

Note 3) Receiver : with built-in TCON IC.

9.3 DATA MAPPING

1) 8 Bit Mode

Note : Assignment in the Mode A(THC63LVDM83R)

Transmitter		AMODE	
Pin No.	Data	=High	=Low
51	TA0	R0 (LSB)	R2
52	TA1	R1	R3
54	TA2	R2	R4
55	TA3	R3	R5
56	TA4	R4	R6
3	TA5	R5	R7 (MSB)
4	TA6	G0 (LSB)	G2
6	TB0	G1	G3
7	TB1	G2	G4
11	TB2	G3	G5
12	TB3	G4	G6
14	TB4	G5	G7 (MSB)
15	TB5	B0 (LSB)	B2
19	TB6	B1	B3
20	TC0	B2	B4
22	TC1	B3	B5
23	TC2	B4	B6
24	TC3	B5	B7 (MSB)
27	TC4	(NA)	(NA)
28	TC5	(NA)	(NA)
30	TC6	DE	DE
50	TD0	R6	R0 (LSB)
2	TD1	R7 (MSB)	R1
8	TD2	G6	G0 (LSB)
10	TD3	G7 (MSB)	G1
16	TD4	B6	B0 (LSB)
18	TD5	B7 (MSB)	B1
25	TD6	(NA)	(NA)

<AMODE=High>

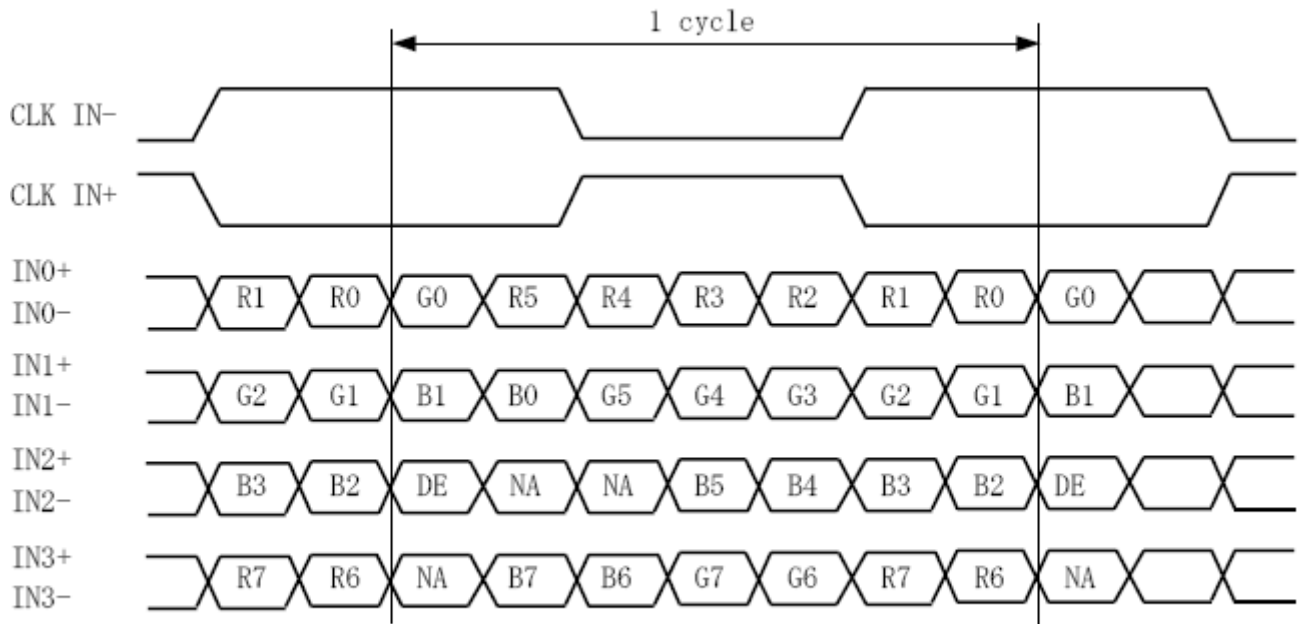

DE:Display Enable
NA:Not Available

<AMODE=Loe or Open>

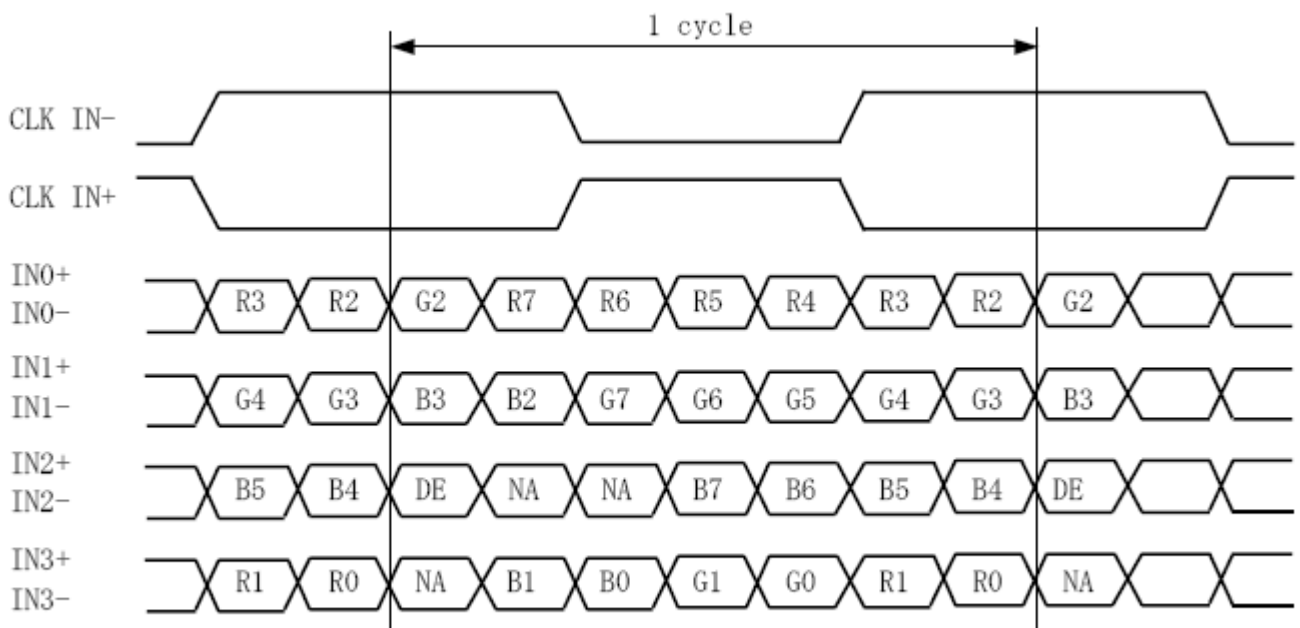

DE:Display Enable
NA:Not Available

2) 6 Bit Mode

Note : Assignment in the Mode A(THC63LVDM83R)

Transmitter		AMODE	
Pin No.	Data	=High	=Low or Open
51	TA0	R0 (LSB)	R0 (LSB)
52	TA1	R1	R1
54	TA2	R2	R2
55	TA3	R3	R3
56	TA4	R4	R4
3	TA5	R5 (MSB)	R5 (MSB)
4	TA6	G0 (LSB)	G0 (LSB)
6	TB0	G1	G1
7	TB1	G2	G2
11	TB2	G3	G3
12	TB3	G4	G4
14	TB4	G5 (MSB)	G5 (MSB)
15	TB5	B0 (LSB)	B0 (LSB)
19	TB6	B1	B1
20	TC0	B2	B2
22	TC1	B3	B3
23	TC2	B4	B4
24	TC3	B5 (MSB)	B5 (MSB)
27	TC4	(NA)	(NA)
28	TC5	(NA)	(NA)
30	TC6	DE	DE
50	TD0	GND	GND
2	TD1	GND	GND
8	TD2	GND	GND
10	TD3	GND	GND
16	TD4	GND	GND
18	TD5	GND	GND
25	TD6	(NA)	(NA)

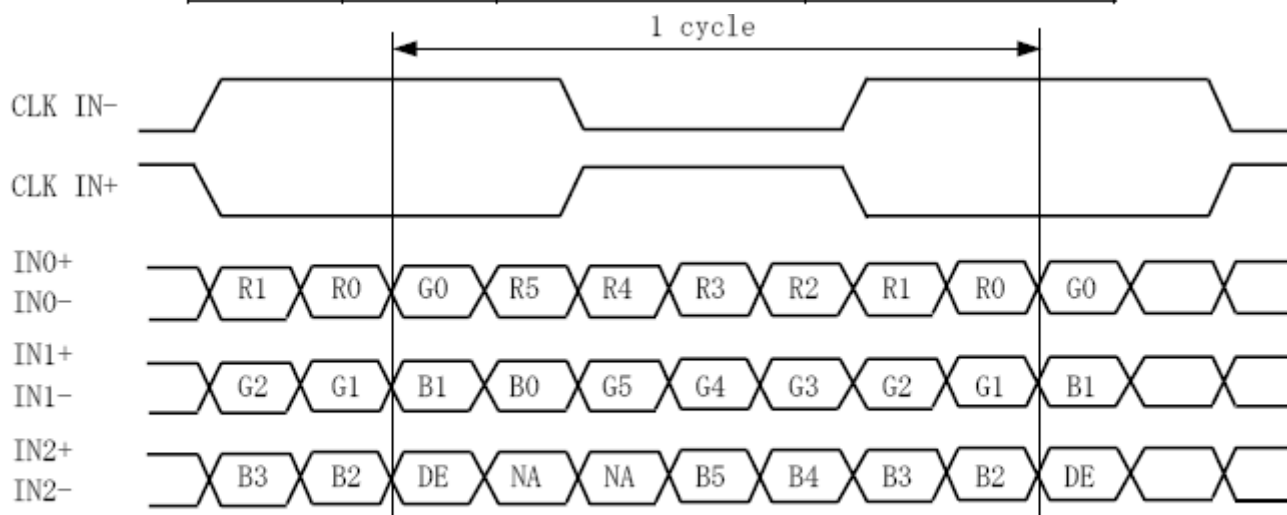

DE:Display Enable

NA:Not Available

* Connection circuit of IN3-, IN3+ for 6 bit mode

① Connect TD0~TD5 to GND

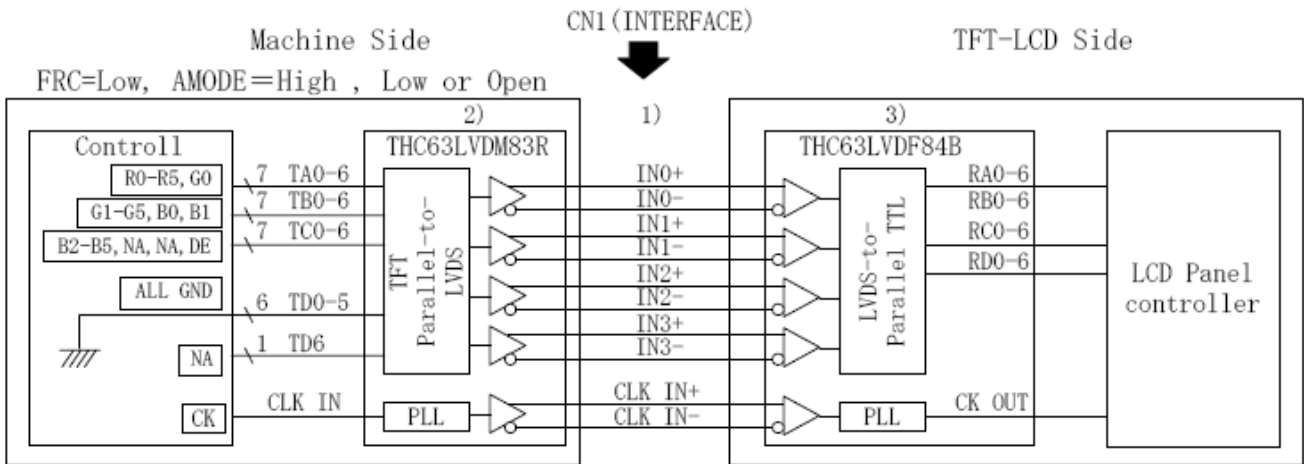

② Connect IN3+ by 3.3V resistor 820Ω and connect IN3- to GND by resistor 470Ω as below circuit. Never turn on LCD when IN3+ and IN3- are Open.

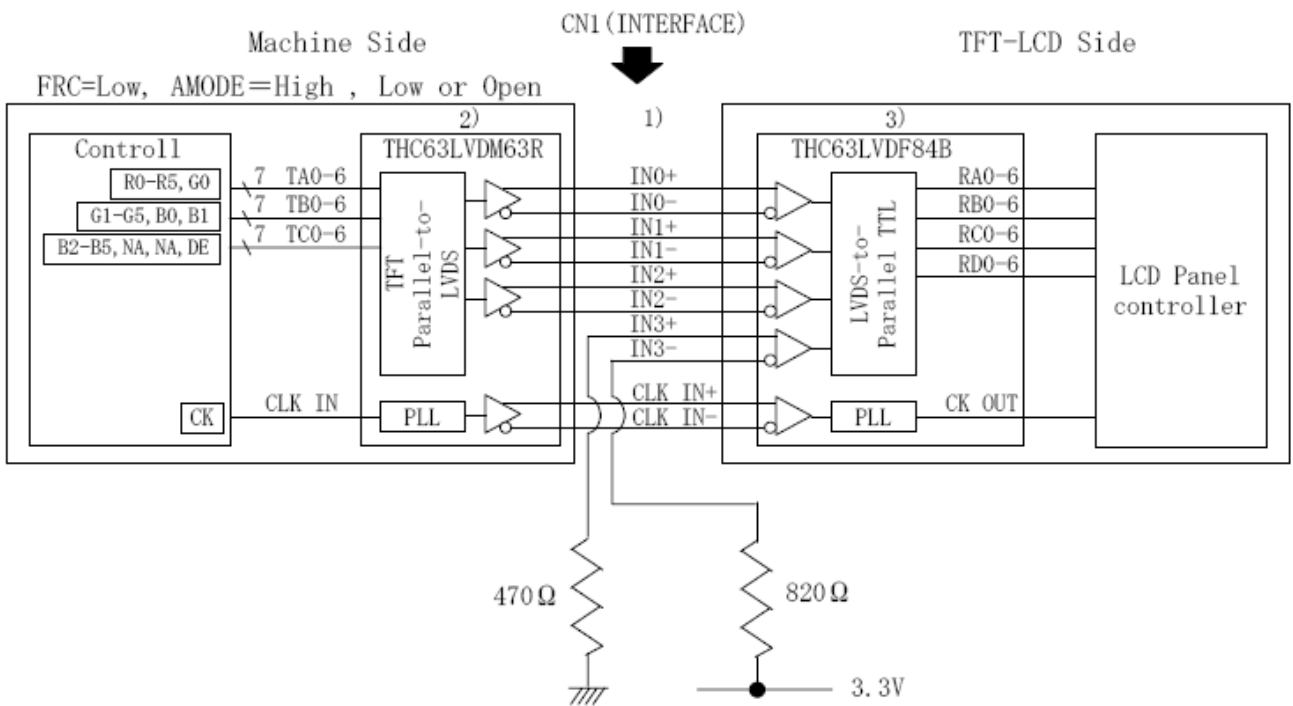

Note 1 : The impedance between differential signal pair should be 100 ohms.

Note 2 : Transmitter is not contained in module.

The recommended transmitter is Thine TH63LVDM83R or equivalent.

Note 3 : The built in receiver is Thine TH63LVDF84B.

9.4 DATA INPUT for DISPLAY COLOR(8BIT MODE)

Input color		Red Data								Green Data								Blue Data							
		R7	R6	R5	R4	R3	R2	R1	R0	G7	G6	G5	G4	G3	G2	G1	G0	B7	B6	B5	B4	B3	B2	B1	B0
		MSB				LSB				MSB				LSB				MSB				LSB			
Basic Color	Black	0	0	0	0	0	0	0	0	0	0	0	0	0	0	0	0	0	0	0	0	0	0	0	0
	Red(255)	1	1	1	1	1	1	1	1	0	0	0	0	0	0	0	0	0	0	0	0	0	0	0	
	Green(255)	0	0	0	0	0	0	0	0	1	1	1	1	1	1	1	0	0	0	0	0	0	0	0	
	Blue(255)	0	0	0	0	0	0	0	0	0	0	0	0	0	0	0	1	1	1	1	1	1	1	1	
	Cyan	0	0	0	0	0	0	0	0	1	1	1	1	1	1	1	1	1	1	1	1	1	1	1	
	Magenta	1	1	1	1	1	1	1	1	0	0	0	0	0	0	0	1	1	1	1	1	1	1	1	
	Yellow	1	1	1	1	1	1	1	1	1	1	1	1	1	1	1	0	0	0	0	0	0	0	0	
	White	1	1	1	1	1	1	1	1	1	1	1	1	1	1	1	1	1	1	1	1	1	1	1	
Red	Black	0	0	0	0	0	0	0	0	0	0	0	0	0	0	0	0	0	0	0	0	0	0	0	
	Red(1)	0	0	0	0	0	0	0	1	0	0	0	0	0	0	0	0	0	0	0	0	0	0	0	
	Red(2)	0	0	0	0	0	0	1	0	0	0	0	0	0	0	0	0	0	0	0	0	0	0	0	
	:	:	:	:	:	:	:	:	:	:	:	:	:	:	:	:	:	:	:	:	:	:	:	:	
	:	:	:	:	:	:	:	:	:	:	:	:	:	:	:	:	:	:	:	:	:	:	:	:	
	Red(253)	1	1	1	1	1	1	0	1	0	0	0	0	0	0	0	0	0	0	0	0	0	0	0	
	Red(254)	1	1	1	1	1	1	1	0	0	0	0	0	0	0	0	0	0	0	0	0	0	0	0	
	Red(255)	1	1	1	1	1	1	1	1	0	0	0	0	0	0	0	0	0	0	0	0	0	0	0	
Green	Black	0	0	0	0	0	0	0	0	0	0	0	0	0	0	0	0	0	0	0	0	0	0	0	
	Green(1)	0	0	0	0	0	0	0	0	0	0	0	0	0	0	1	0	0	0	0	0	0	0	0	
	Green(2)	0	0	0	0	0	0	0	0	0	0	0	0	0	1	0	0	0	0	0	0	0	0	0	
	:	:	:	:	:	:	:	:	:	:	:	:	:	:	:	:	:	:	:	:	:	:	:	:	
	:	:	:	:	:	:	:	:	:	:	:	:	:	:	:	:	:	:	:	:	:	:	:	:	
	Green(253)	0	0	0	0	0	0	0	0	1	1	1	1	1	1	0	1	0	0	0	0	0	0	0	
	Green(254)	0	0	0	0	0	0	0	0	1	1	1	1	1	1	0	0	0	0	0	0	0	0	0	
	Green(255)	0	0	0	0	0	0	0	0	1	1	1	1	1	1	1	0	0	0	0	0	0	0	0	
Blue	Black	0	0	0	0	0	0	0	0	0	0	0	0	0	0	0	0	0	0	0	0	0	0	0	
	Blue(1)	0	0	0	0	0	0	0	0	0	0	0	0	0	0	0	0	0	0	0	0	0	0	1	
	Blue(2)	0	0	0	0	0	0	0	0	0	0	0	0	0	0	0	0	0	0	0	0	0	1	0	
	:	:	:	:	:	:	:	:	:	:	:	:	:	:	:	:	:	:	:	:	:	:	:	:	
	:	:	:	:	:	:	:	:	:	:	:	:	:	:	:	:	:	:	:	:	:	:	:	:	
	Blue(253)	0	0	0	0	0	0	0	0	0	0	0	0	0	0	0	1	1	1	1	1	1	0	1	
	Blue(254)	0	0	0	0	0	0	0	0	0	0	0	0	0	0	0	1	1	1	1	1	1	1	0	
	Blue(255)	0	0	0	0	0	0	0	0	0	0	0	0	0	0	0	1	1	1	1	1	1	1	1	

Note 1) Definition of gray scale : Color(n) Number in parenthesis indicates gray scale level. Larger number corresponds to brighter level.

Note 2) Data Signal : 1 : High, 0 : Low

(6BIT MODE)

Input		Red Data						Green Data						Blue Data					
		R5	R4	R3	R2	R1	R0	G5	G4	G3	G2	G1	G0	B5	B4	B3	B2	B1	B0
color		MSB			LSB			MSB			LSB			MSB			LSB		
Basic Color	Black	0	0	0	0	0	0	0	0	0	0	0	0	0	0	0	0	0	0
	Red(63)	1	1	1	1	1	1	0	0	0	0	0	0	0	0	0	0	0	0
	Green(63)	0	0	0	0	0	0	1	1	1	1	1	1	0	0	0	0	0	0
	Blue(63)	0	0	0	0	0	0	0	0	0	0	0	0	1	1	1	1	1	1
	Cyan	0	0	0	0	0	0	1	1	1	1	1	1	1	1	1	1	1	1
	Magenta	1	1	1	1	1	1	0	0	0	0	0	0	1	1	1	1	1	1
	Yellow	1	1	1	1	1	1	1	1	1	1	1	1	0	0	0	0	0	0
	White	1	1	1	1	1	1	1	1	1	1	1	1	1	1	1	1	1	1
Red	Black	0	0	0	0	0	0	0	0	0	0	0	0	0	0	0	0	0	0
	Red(1)	0	0	0	0	0	1	0	0	0	0	0	0	0	0	0	0	0	0
	Red(2)	0	0	0	0	1	0	0	0	0	0	0	0	0	0	0	0	0	0
	:	:	:	:	:	:	:	:	:	:	:	:	:	:	:	:	:	:	:
	:	:	:	:	:	:	:	:	:	:	:	:	:	:	:	:	:	:	:
	Red(61)	1	1	1	1	0	1	0	0	0	0	0	0	0	0	0	0	0	0
	Red(62)	1	1	1	1	1	0	0	0	0	0	0	0	0	0	0	0	0	0
	Red(63)	1	1	1	1	1	1	0	0	0	0	0	0	0	0	0	0	0	0
Green	Black	0	0	0	0	0	0	0	0	0	0	0	0	0	0	0	0	0	0
	Green(1)	0	0	0	0	0	0	0	0	0	0	0	1	0	0	0	0	0	0
	Green(2)	0	0	0	0	0	0	0	0	0	0	1	0	0	0	0	0	0	0
	:	:	:	:	:	:	:	:	:	:	:	:	:	:	:	:	:	:	:
	:	:	:	:	:	:	:	:	:	:	:	:	:	:	:	:	:	:	:
	Green(61)	0	0	0	0	0	0	1	1	1	1	0	1	0	0	0	0	0	0
	Green(62)	0	0	0	0	0	0	1	1	1	1	1	0	0	0	0	0	0	0
	Green(63)	0	0	0	0	0	0	1	1	1	1	1	1	0	0	0	0	0	0
Blue	Black	0	0	0	0	0	0	0	0	0	0	0	0	0	0	0	0	0	0
	Blue(1)	0	0	0	0	0	0	0	0	0	0	0	0	0	0	0	0	0	1
	Blue(2)	0	0	0	0	0	0	0	0	0	0	0	0	0	0	0	0	1	0
	:	:	:	:	:	:	:	:	:	:	:	:	:	:	:	:	:	:	:
	:	:	:	:	:	:	:	:	:	:	:	:	:	:	:	:	:	:	:
	Blue(61)	0	0	0	0	0	0	0	0	0	0	0	0	1	1	1	1	0	1
	Blue(62)	0	0	0	0	0	0	0	0	0	0	0	0	1	1	1	1	1	0
	Blue(63)	0	0	0	0	0	0	0	0	0	0	0	0	1	1	1	1	1	1

Note 1) Definition of gray scale : Color(n) Number in parenthesis indicates gray scale level. Larger number corresponds to brighter level.

Note 2) Data Signal : 1 : High, 0 : Low

9.5 INTERFACE TIMING

(1) LVDS Receiver Timing

(Interface of TFT module)

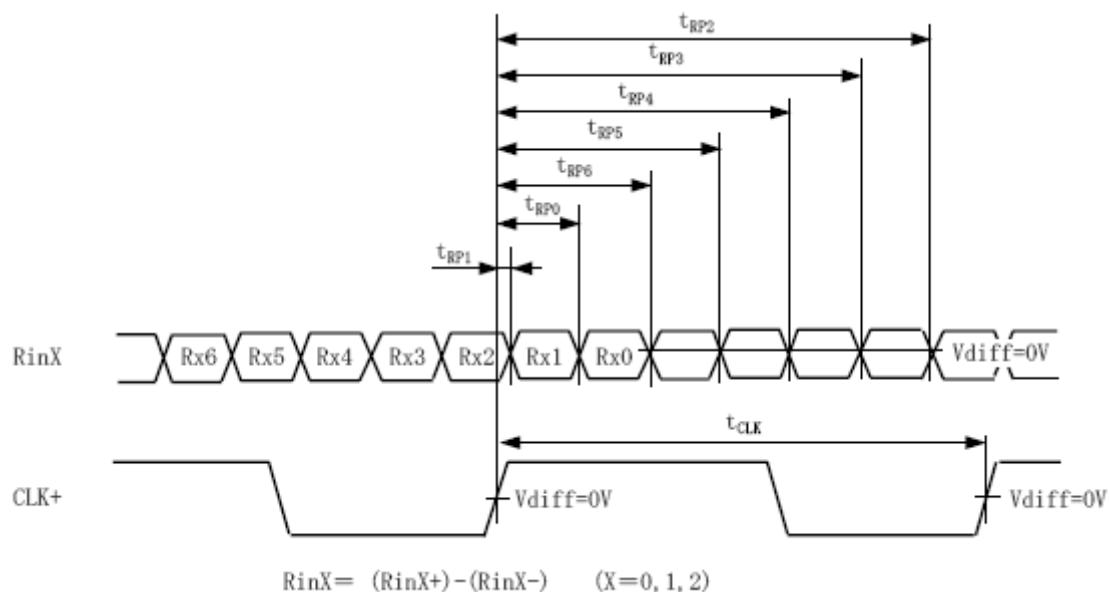

Item	Symbol	Min.	Typ.	Max.	Unit	Note
DCLK	FREQUENCY	$1/t_{CLK}$	35	40	45	MHz
RinX (X=0,1,2)	0 data position	t_{RP0}	$1/7 * t_{CLK} - 0.49$	$1/7 * t_{CLK}$	$1/7 * t_{CLK} + 0.49$	ns
	1st data position	t_{RP1}	-0.49	0	+0.49	
	2nd data position	t_{RP2}	$6/7 * t_{CLK} - 0.49$	$6/7 * t_{CLK}$	$6/7 * t_{CLK} + 0.49$	
	3rd data position	t_{RP3}	$5/7 * t_{CLK} - 0.49$	$5/7 * t_{CLK}$	$5/7 * t_{CLK} + 0.49$	
	4th data position	t_{RP4}	$4/7 * t_{CLK} - 0.49$	$4/7 * t_{CLK}$	$4/7 * t_{CLK} + 0.49$	
	5th data position	t_{RP5}	$3/7 * t_{CLK} - 0.49$	$3/7 * t_{CLK}$	$3/7 * t_{CLK} + 0.49$	
	6th data position	t_{RP6}	$2/7 * t_{CLK} - 0.49$	$2/7 * t_{CLK}$	$2/7 * t_{CLK} + 0.49$	

(2) Timing converter timing

(Input timing for transmitter)

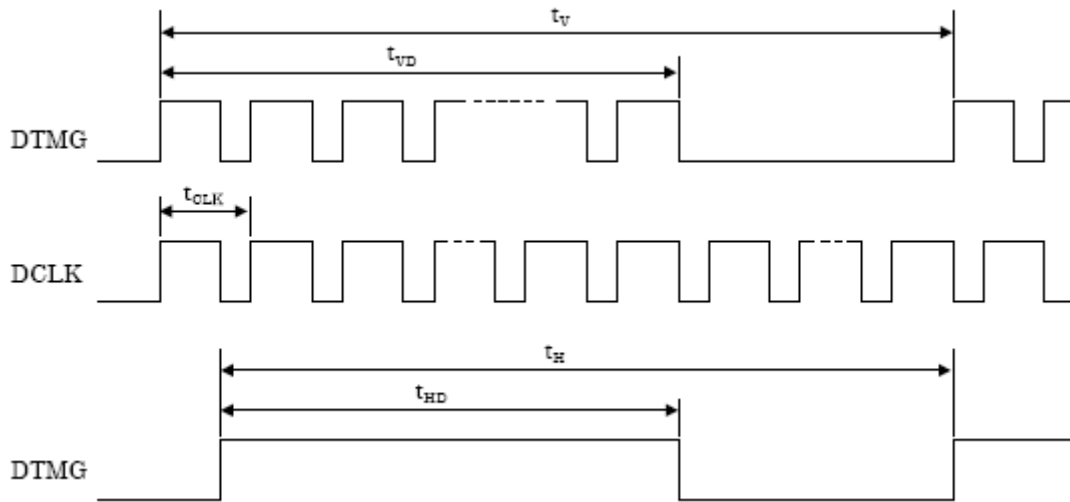

The timings except mentioned above are referred to the specifications of your transmitter.

Item		Symbol	Min.	Typ.	Max.	Unit
DCLK	Cycle time	t_{CLK}	22.2	25.0	28.5	ns
DTMG	Horizontal Cycle	t_H	850	1060	1600	t_{CLK}
	Horizontal Valid Data width	t_{HD}	800	800	800	
	Vertical Cycle	t_V	603	628	1000	t_H
	Vertical Valid Data width	t_{VD}	600	600	600	

Note 1: It counts by a typical value of line cycle time.

(3) TIMING BETWEEN INTERFACE SIGNAL AND POWER SUPPLY

Power Supply, Input Signal and Backlight Voltage ON/OFF/REENTRY should comply with the following sequence.

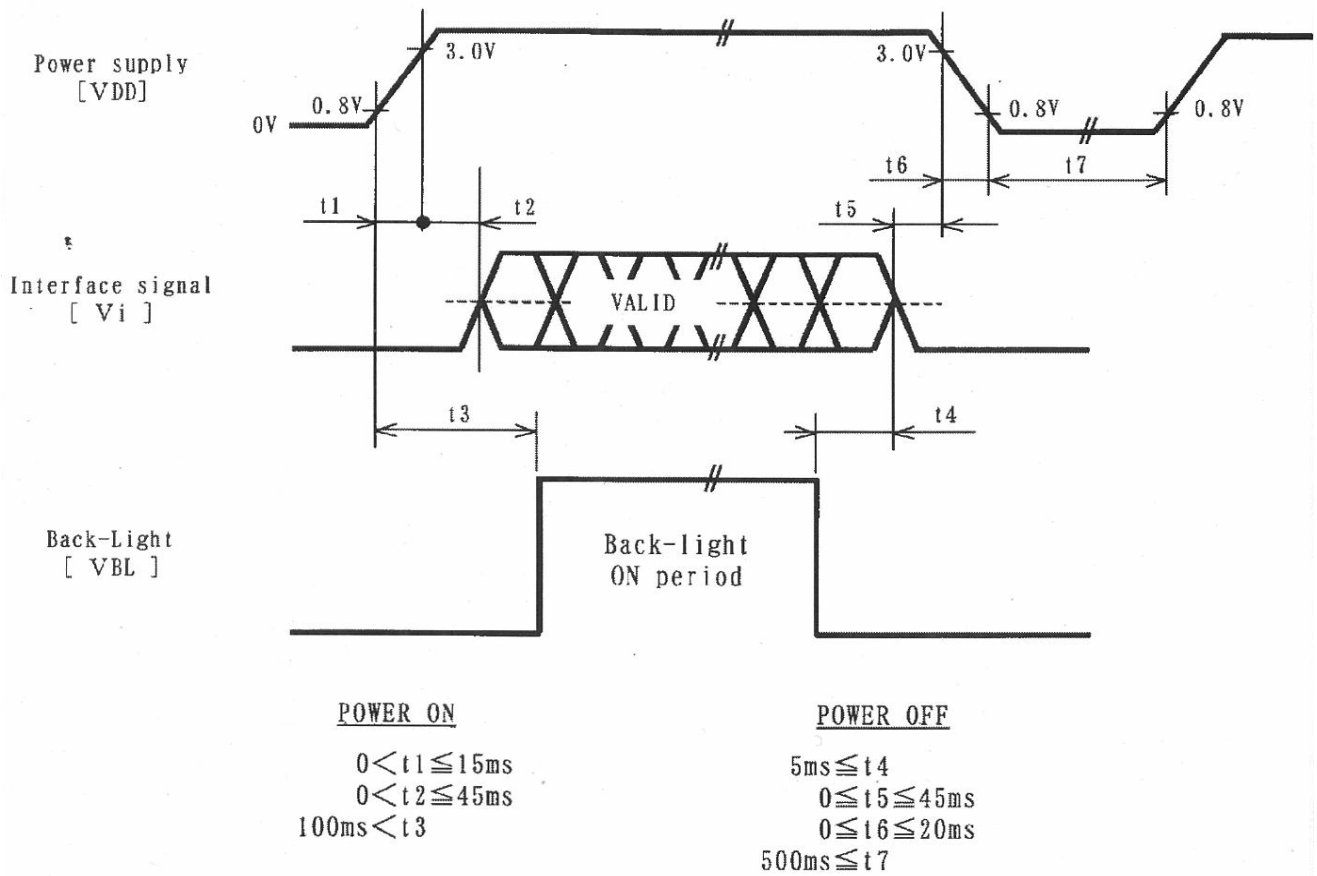

Note 1: In order to prevent electronic parts from destruction caused by latch-up, please input signal after Power Supply Voltage ON. In addition, please turn off signals before power supply voltage OFF.

Note 2: In order to prevent from function error due to residual charge, please reenter power supply voltage after time stipulated with t7.

Note 3: Please turn on Backlight after signals fix and turn off before signals down, otherwise noise appears in the display. The noise cause no problem with display performance in case of timing sequence comply with the spec.

10. OUTLINE DIMENSIONS

10.1 SURFACE SIDE

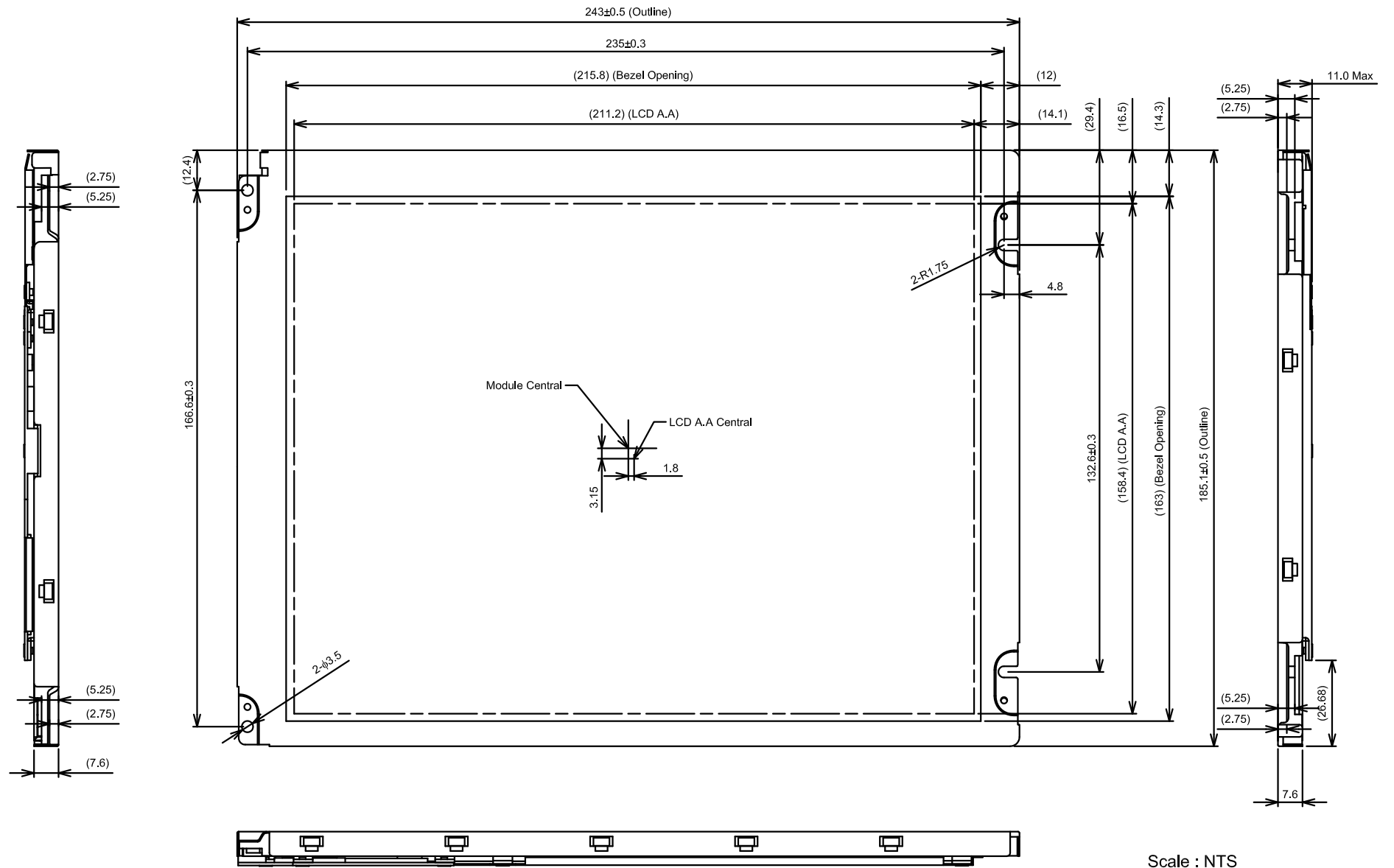

Scale : NTS
Unit : mm

10.2 BACK SIDE

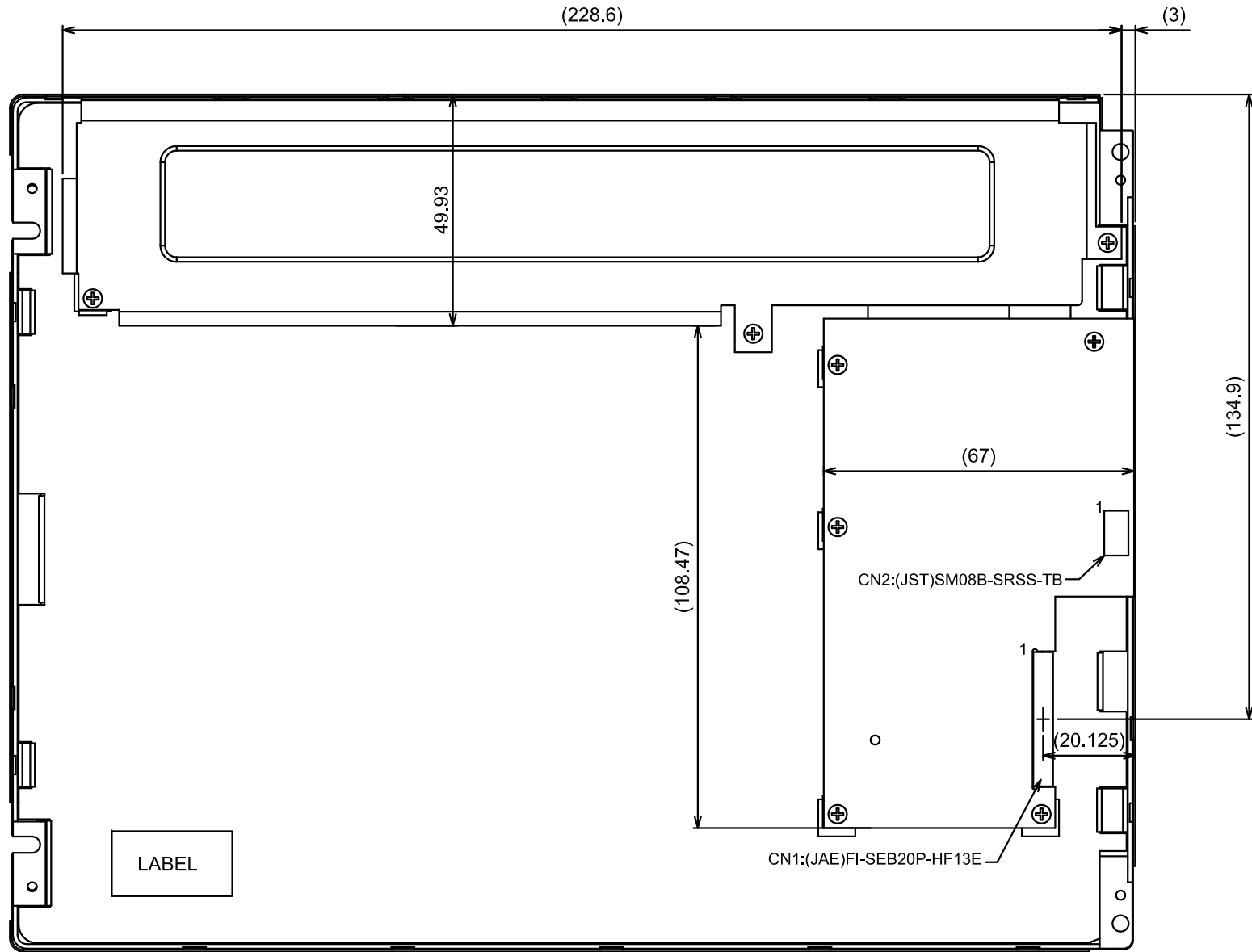

Scale : NTS
Unit : mm

11. APPEARANCE STANDARD

The appearance inspection is performed in a dark room around 1200 lx based on the conditions as below:

- The distance between inspector's eyes and display is 30 cm.
- The viewing zone is defined with angle θ shown in Fig. 11.1 The inspection should be performed within 45° when display is shut down. The inspection should be performed within 5° when display is power on.

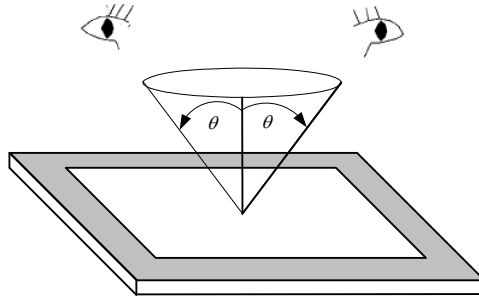

Fig. 11.1

11.1 THE DEFINITION OF LCD ZONE

LCD panel is divided into 3 areas as shown in Fig.11.2 for appearance specification in next section. A zone is the LCD active area (dot area); B zone is the area, which extended 1 mm out from LCD active area; C zone is the area between B zone and metal frame.

In terms of housing design, B zone is the recommended window area customers' housing should be located in.

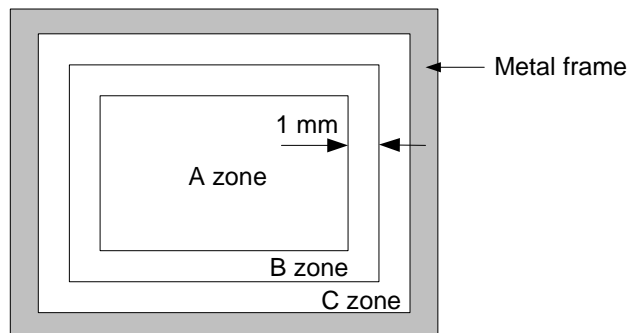

Fig. 11.2

11.2 LCD APPEARANCE SPECIFICATION

The specification as below is defined as the amount of unexpected phenomenon or material in different zones of LCD panel. The definitions of length, width and average diameter using in the table are shown in Fig. 11.3 and Fig. 11.4.

Item	Criteria				Applied zone
	Length (mm)	Width (mm)	Maximum number	Minimum space	
Scratches	Ignored	$W \leq 0.02$	Ignored	-	A,B
	$L \leq 40$	$0.02 < W \leq 0.04$	10	-	
	$L \leq 20$	$W \leq 0.04$	10	-	
	Distinguished one is acceptable (To be judged by HITACHI standard)				
Dent	Same as above				A
Wrinkles in polarizer	Same as above				A
Bubbles on polarizer	Average diameter (mm)		Maximum number		A
	$D \leq 0.3$		Ignored		
	$0.3 < D \leq 0.5$		10		
	$0.5 < D \leq 1.0$		5		
1) Stains 2) Foreign Materials 3) Dark Spot	Filamentous (Line shape)				A,B
	Length (mm)	Width (mm)	Maximum number		
	L : Ignored	$W \leq 0.06$	Ignored		
	$L \leq 1.0$	$0.06 < W$	Ignored		
	$1.0 < L$		(See Dot shape)		
	Round (Dot shape)				A,B
	Average diameter (mm)	Maximum number	Minimum Space		
	$D \leq 0.45$	Ignored	-		
	$0.45 < D \leq 0.7$	5	-		
	$0.7 < D$	none	-		
Those wiped out easily are acceptable					
Color Tone	To be judged by HITACHI STANDARD				A
Color Uniformity	Same as above				A
Dot-Defect (Note 1)		Type	Maximum number		A
	Bright dot-defect	1 dot	4		
		2 dot	2		
		In total	6		
	Dark dot-defect	1 dot	5		
		2 dot	2		
		In total	5		
	In total		11		

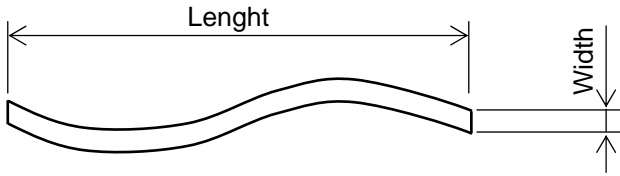
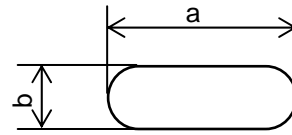

Fig 11.3



$$\text{Average diameter} = \frac{a+b}{2}$$

Fig 11.4

Note 1: The definitions of dot defect are as below:

- The defect area of the dot must be bigger than half of a dot.
- For bright dot-defect, showing black pattern, the dot's brightness must be over 30% brighter than others.
- For dark dot-defect, showing white pattern, the dot's brightness must be under 70% darker than others.
- The definition of 1-dot-defect is the defect-dot, which is isolated and no adjacent defect-dot.
- The definition of adjacent dot is shown as Fig. 11.5.
- The Density of dot defect is defined in the area within diameter $\phi = 20\text{mm}$.

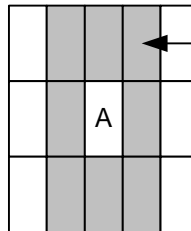

The dots colored gray are adjacent to defect-dot A.

Fig 11.5

12. PRECAUTIONS

12.1 PRECAUTIONS of ESD

- 1) Before handling the display, please ensure your body has been connected to ground to avoid any damages by ESD. Also, do not touch display's interface directly when assembling.
- 1) Please remove the protection film very slowly before turning on the display to avoid generating ESD.

12.2 PRECAUTIONS of HANDLING

- 1) In order to keep the appearance of display in good condition, please do not rub any surfaces of the displays by sharp tools harder than 3H, especially touch panel, metal frame and polarizer.
- 2) Please do not pile the displays in order to avoid any scars leaving on the display. In order to avoid any injuries, please pay more attention for the edges of glasses and metal frame, and wear finger cots to protect yourself and the display before working on it.
- 2) Touching the display area or the terminal pins with bare hand is prohibited. This is because it will stain the display area and cause poor insulation between terminal pins, and might affect display's electrical characteristics furthermore.
- 3) Do not use any harmful chemicals such as acetone, toluene, and isopropyl alcohol to clean display's surfaces.
- 4) Please use soft cloth or absorbent cotton with ethanol to clean the display by gently wiping. Moreover, when wiping the display, please wipe it by horizontal or vertical direction instead of circling to prevent leaving scars on the display's surface, especially polarizer.
- 5) Please wipe any unknown liquids immediately such as saliva, water or dew on the display to avoid color fading or any permanently damages.
- 6) Maximum pressure to the surface of the display must be less than 1.96×10^4 Pa. If the area of adding pressure is less than 1 cm^2 , the maximum pressure must be less than 1.96N.

12.3 PRECAUTIONS OF OPERATING

- 1) Please input signals and voltages to the displays according to the values defined in the section of electrical characteristics to obtain the best performance. Any voltages over than absolute maximum rating will cause permanent damages to this display. Also, any timing of the signals out of this specification would cause unexpected performance.
- 2) When the display is operating at significant low temperature, the response time will be slower than it at 25°C . In high temperature, the color will be slightly dark and blue compared to original pattern. However, these are temperature-related phenomenon of LCD and it will not cause permanent damages to the display when used within the operating temperature.
- 3) The use of screen saver or sleep mode is recommended when static images are likely for long periods of time. This is to avoid the possibility of image sticking.
- 4) Spike noise can cause malfunction of the circuit. The recommended limitation of spike noise is no bigger than $\pm 100 \text{ mV}$.

KAOHSIUNG HITACHI ELECTRONICS CO., LTD.	SHEET NO.	7B64PS 2712-TX26D12VM0AAA-1	PAGE	12-1/2
--	--------------	-----------------------------	------	--------

12.4 PRECAUTIONS of STORAGE

If the displays are going to be stored for years, please be aware the following notices.

- 1) Please store the displays in a dark room to avoid any damages from sunlight and other sources of UV light.
- 2) The recommended long term storage temperature is between 10 C° ~35 C° and 55%~75% humidity to avoid causing bubbles between polarizer and LCD glasses, and polarizer peeling from LCD glasses.
- 3) It would be better to keep the displays in the container, which is shipped from Hitachi, and do not unpack it.
- 4) Please do not stick any labels on the display surface for a long time, especially on the polarizer.

13. DESIGNATION of LOT MARK

1) The lot mark is showing in Fig.13.1. First 4 digits are used to represent production lot, T represented made in Taiwan, and the last 6 digits are the serial number.

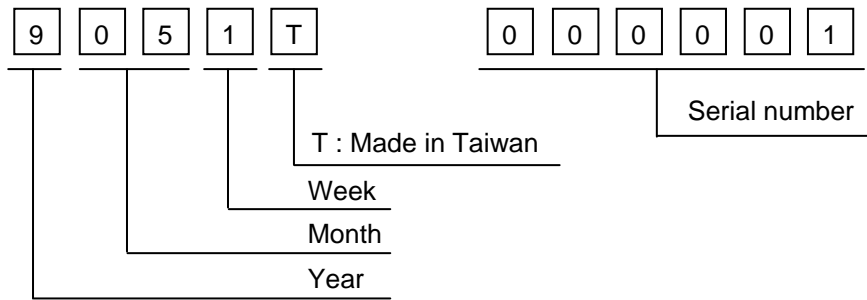

2) The tables as below are showing what the first 4 digits of lot mark are shorted for.

Year	Mark
2008	8
2009	9
2010	0
2011	1
2012	2

Month	Mark	Month	Mark
1	01	7	07
2	02	8	08
3	03	9	09
4	04	10	10
5	05	11	11
6	06	12	12

Week (Days)	Mark
1~7	1
8~14	2
15~21	3
22~28	4
29~31	5

3) Except letters I and O, revision number will be shown on lot mark and following letters A to Z.

4) The location of the lot mark is on the back of the display shown in Fig. 13.1.

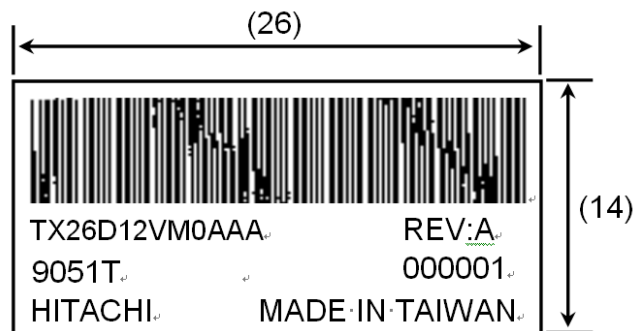

Fig 13.1