



# SPECIFICATIONS FOR LCD MODULE

CUSTOMER	STD
MODEL	WM-F2432VP-6FLWa VER. 01
CUSTOMER APPROVED	

APPROVED BY	CHECKED BY	ORGANIZED BY
 <p>LCM 產品部 2009/4/10 黃建民</p>	 <p>LCM 產品部 2009/4/10 鍾永山</p>	 <p>LCM 產品部 2009/4/10 王以武</p>

APPROVAL FOR SPECIFICATIONS ONLY

APPROVAL FOR SPECIFICATIONS AND SAMPLE

10 , Jianguo Rd., Tanzih Township, Taichung County 427, TAIWAN R.O.C.

TEL:886-4-25318899,FAX:886-4-25310868

## History of Version

Version	Contents	Date	Note
a1	NEW VERSION	9.Apr.2009	SPEC

<b>Contents</b>	<b>Page</b>
<b>(1) Electronic Units</b> .....	<b>4</b>
1.1 Absolute Maximum Ratings.....	4
1.2 Electrical Characteristics.....	4
1.3 Interface Pin Function .....	5
1.4 Power Supply for LCD Module.....	7
1.5 Block Diagram with Display RAM Address.....	8
1.6 Timing Characteristic.....	11
1.7 Power ON/OFF SEQUENCE .....	12
<b>(2) Electro-optical Units</b> .....	<b>13</b>
2.1 Electro-optical Characteristics.....	13
2.2 Optical Definitions .....	14
<b>(3) Mechanical Units</b> .....	<b>14</b>
3.1 Mechanical Diagram .....	14
3.2 Back-light Specification .....	15
3.3 Packing Method .....	16
<b>(4) Quality Units</b> .....	<b>17</b>
4.1 Specification of Quality Assurance .....	17
4.2 Standard Specification for Reliability .....	19
4.3 Precautions in Use of LCM .....	20
<b>(5) Substance Management Units</b> .....	<b>20</b>
5.1 Product Substances Management Documentation .....	20

## (1) Electronic Units

### 1.1 Absolute Maximum Ratings

ITEM	SYMBOL	MIN	TYP	MAX	UNIT
Operating Temperature	TOP	-20	-	+70	
Storage Temperature	TST	-30	-	+80	
Supply Voltage for Analog	VCI-VSS	-0.3	-	+4.6	V
Supply Voltage for Digital	VDD-VSS	-0.3	-	+4.6	V
Static Electricity	Be sure that you are grounded when handling LCM.				

### 1.2 Electrical Characteristics

(Ta=25 )

ITEM	SYMBOL	CONDITION	MIN.	TYP.	MAX.	UNIT
Supply Voltage for Analog	VCI	-	2.65	2.75	2.85	V
Supply Voltage for Digital	VDD	-	1.7	1.8	1.9	V
Input Signal High Voltage	VIH	-	0.7VDD	-	VDD	V
Input Signal Low Voltage	VIL	-	0	-	0.3VDD	V
Output Signal High Voltage	VOH	-	0.8VDD	-	VDD	V
Output Signal Low Voltage	VOL	-	0	-	0.2VDD	V
Supply Current for Analog	*ICI	-	-	-	8.5	mA
Supply Current for Digital	*IDD	-	-	-	0.14	mA
Used IC	NT39116					

\*ICI Measurement condition is for all pixels on

\*IDD Measurement condition is for all pixels on

### 1.3 Interface Pin Function

#### CN1:

NO	SYMBOL	I / O	FUNCTION
1	D0	I/O	Data Bus.
2	D1	I/O	Data Bus.
3	D2	I/O	Data Bus.
4	D3	I/O	Data Bus.
5	D4	I/O	Data Bus.
6	D5	I/O	Data Bus.
7	D6	I/O	Data Bus.
8	D7	I/O	Data Bus.
9	D8	I/O	Data Bus.
10	D9	I/O	Data Bus.
11	D10	I/O	Data Bus.
12	D11	I/O	Data Bus.
13	D12	I/O	Data Bus.
14	D13	I/O	Data Bus.
15	D14	I/O	Data Bus.
16	D15	I/O	Data Bus.
17	D16	I/O	Data Bus.
18	D17	I/O	Data Bus.
19	RES	I	Reset pad.
20	CSX	I	Chip Select
21	WRX	I	Write enable in 8080-parallel interface.
22	RDX	I	Read enable in 8080-parallel interface
23	D/CX	I	Display data / Command selection pin in parallel interface
24	TE	O	Tearing effect output pin to synchronize MCU to frame writing. activated by S/W command
25	GND	P	Ground
26	VCI	P	Power supply for analog system
27	VDD	P	Power supply for I/O system
28	IM0	I	MCU Parallel interface bus and Serial interface select
29	IM1	I	MCU Parallel interface bus and Serial interface select
30	IM2	I	MCU Parallel interface bus and Serial interface select
31	P68	I	8080 /6800 MCU Interface mode select
32	SPI4W	I	4-line or 3-line Serial interface select
33	LED+	P	Anode for LED backlighting

34	LED1-	P	Cathode NO.1 for LED backlighting
35	LED2-	P	Cathode NO.2 for LED backlighting

## 1.4 Power Supply for LCD Module

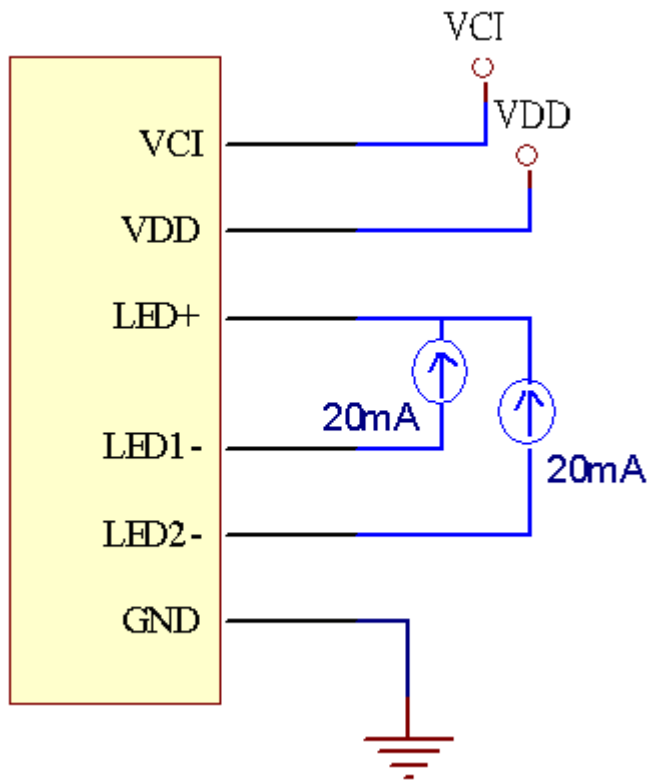

Note: 1. The panel : VCI=2.75V, VDD=1.8V.

## 1.5 Block Diagram with Display RAM Address

### 1.5-1. Block Diagram

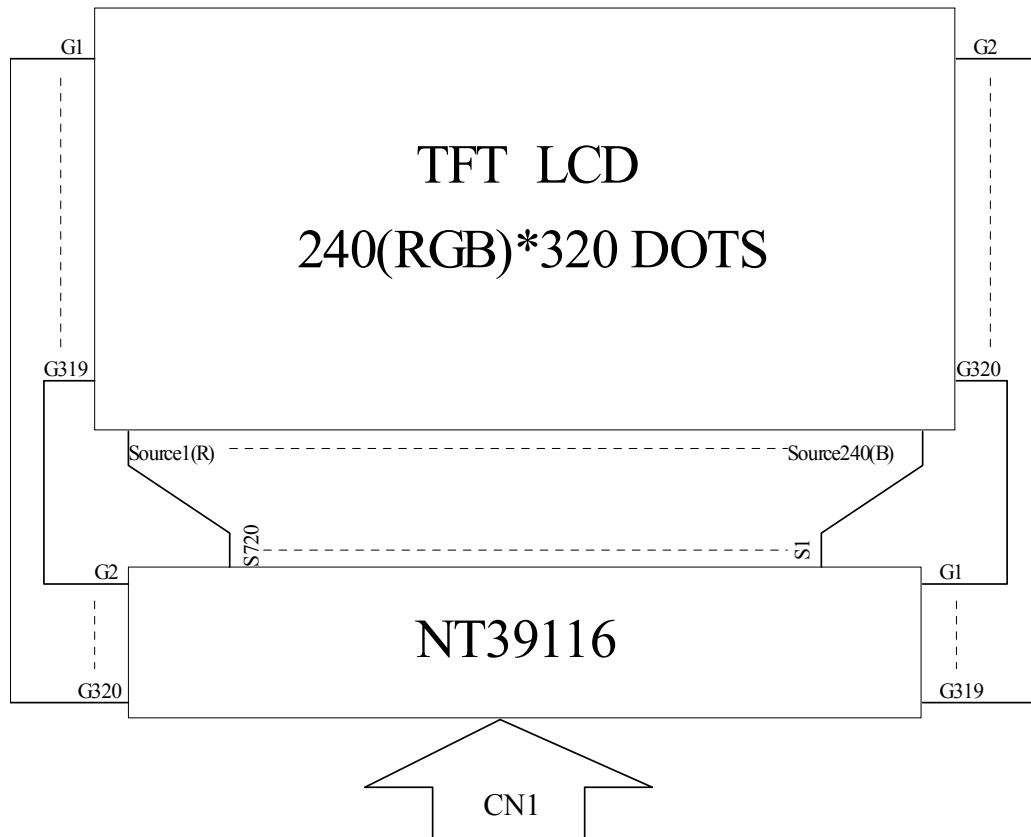

### 1.5-2. Display Data RAM:

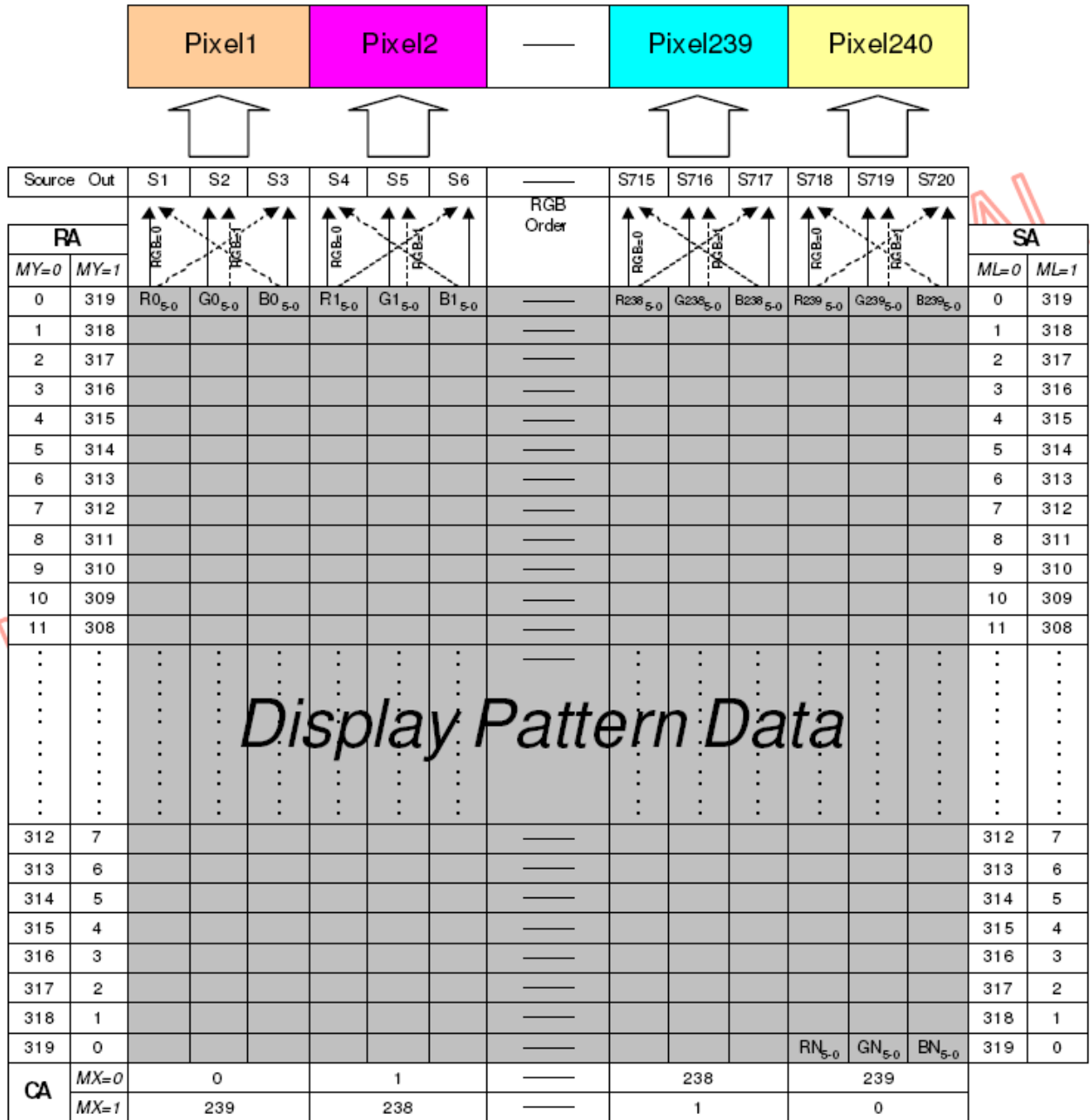

### 1.5-3. Initialization Table:

NO	Document Number	Attachment file
1	MF2432VP-IN1-101	

Double-Click the "Attachment Icon" above for opening attachment file.

## 1.6 Timing Characteristic

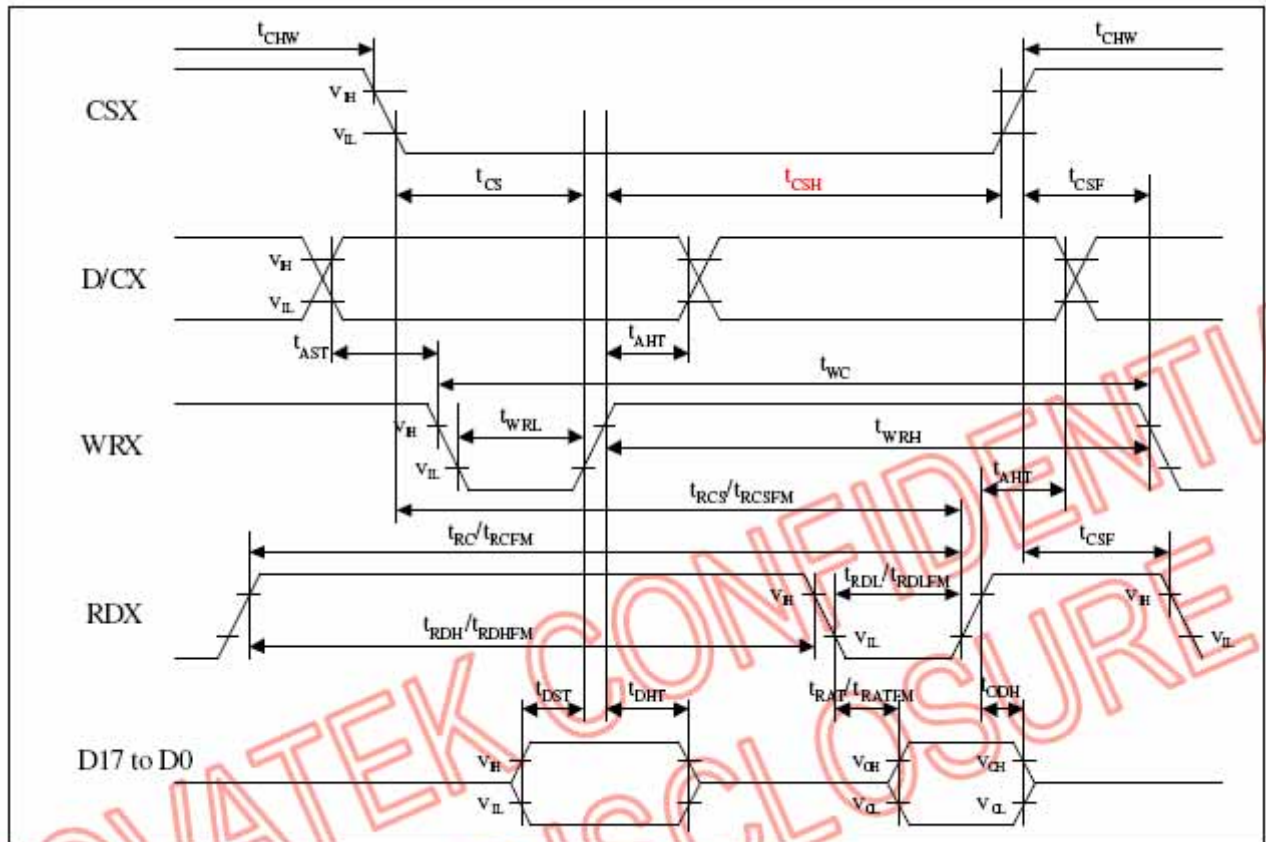

Fig. 7.7.1 Parallel Interface characteristics (80-series MPU)

Signal	Symbol	Parameter	MIN	MAX	Unit	Description
D/CX	$t_{AST}$	Address setup time	0		ns	-
	$t_{AHT}$	Address hold time (Write/Read)	10		ns	
CSX	$t_{CHW}$	Chip select "H" pulse width	0		ns	-(3-transfer for one pixel)
	$t_{CS}$	Chip select setup time (Write)	15		ns	
	$t_{RCS}$	Chip select setup time (Read ID)	45		ns	
	$t_{RCSFM}$	Chip select setup time (Read FM)	355		ns	
	$t_{CSF}$	Chip select wait time (Write/Read)	10		ns	
	$t_{CSH}$	Chip select hold time	10		ns	
WRX	$t_{WC}$	Write cycle	65		ns	
	$t_{WRH}$	Control pulse "H" duration	15		ns	
	$t_{WRL}$	Control pulse "L" duration	15		ns	
RDX (ID)	$t_{RC}$	Read cycle (ID)	160		ns	When read ID data
	$t_{RDH}$	Control pulse "H" duration (ID)	90		ns	
	$t_{RDH}$	Control pulse "L" duration (ID)	45		ns	
RDX (FM)	$t_{RCFM}$	Read cycle (FM)	450		ns	When read from frame memory
	$t_{RDHEM}$	Control pulse "H" duration (FM)	90		ns	
	$t_{RDLEFM}$	Control pulse "L" duration (FM)	355		ns	
D[17:0]	$t_{DST}$	Data setup time	10		ns	For maximum $C_L=30pF$ For minimum $C_L=8pF$
	$t_{DHT}$	Data hold time	10		ns	
	$t_{RAT}$	Read access time (ID)		40	ns	
	$t_{RATFM}$	Read access time (FM)		340	ns	
	$t_{ODH}$	Output disable time	20	80	ns	

Note 1:  $V_{DD1}=1.65$  to  $3.3V$ ,  $V_{DD}=2.5$  to  $3.3V$ ,  $AGND=CGND=VGS=DGND=0V$ ,  $T_a=-30$  to  $70$  °C (to  $+85$  °C no damage)

## 1.7 Power ON/OFF SEQUENCE

### 1.7.1 Power ON Sequence

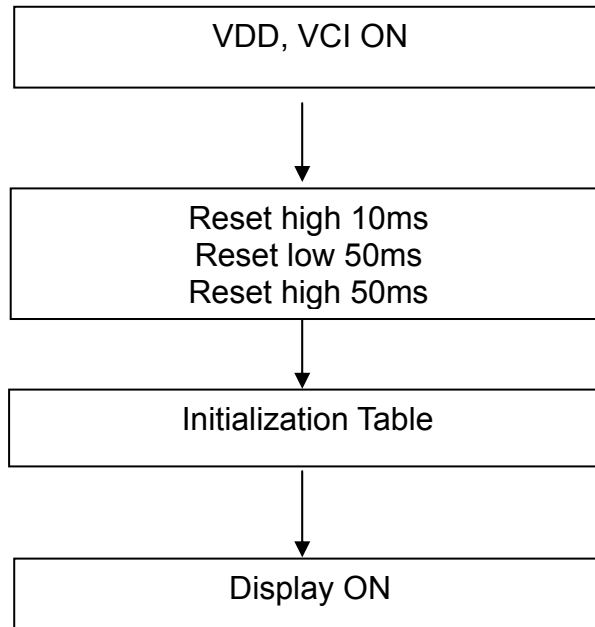

### 1.7.2 Power OFF Sequence

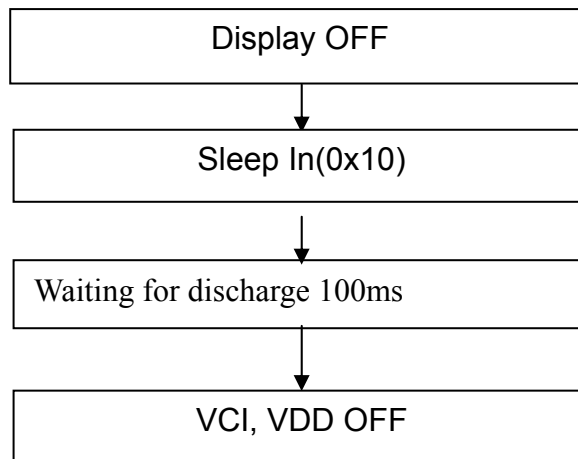

## (2) Electro-optical Units

### 2.1 Electro-optical Characteristics

ITEM	SYMBOL	CONDITION	MIN.	TYP.	MAX.	UNIT
View Angle	$\psi = 90^\circ$ (12H)	CR $\geq$ 10	40	50	-	deg.
	$\psi = 270^\circ$ (6H)		40	50	-	deg.
	$\psi = 180^\circ$ (9H)		55	60	-	deg.
	$\psi = 0^\circ$ (3H)		15	20	-	deg.
Contrast Ratio	CR	Ta=25	200	-	-	-
Response Time	Tr	Ta=25	-	6	-	ms
	Td		-	18	-	ms
Color Coordinate	Rx	Ta=25	0.54	0.60	0.66	-
	Ry		0.27	0.33	0.39	
	Gx		0.25	0.31	0.37	
	Gy		0.5	0.56	0.62	
	Bx		0.08	0.14	0.20	
	By		0.05	0.11	0.17	
	Wx		0.25	0.31	0.37	
	Wy		0.26	0.32	0.38	
LCD Type	TFT , ( POSITIVE / Transmissive )					
Viewing Direction	6:00					

Notes : All the optical data should be measured when the display's driven under the TYP. condition.

## 2.2 Optical Definitions

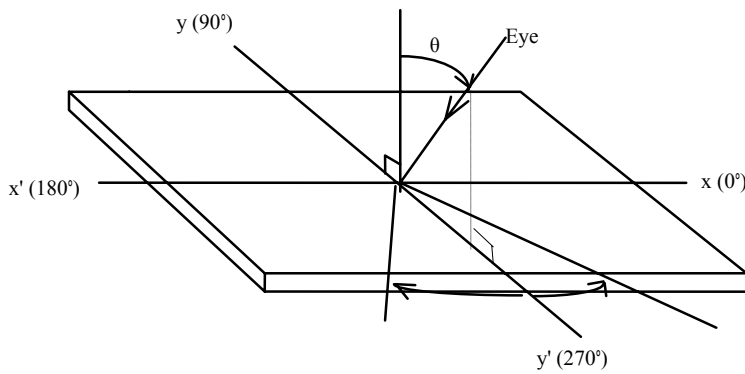
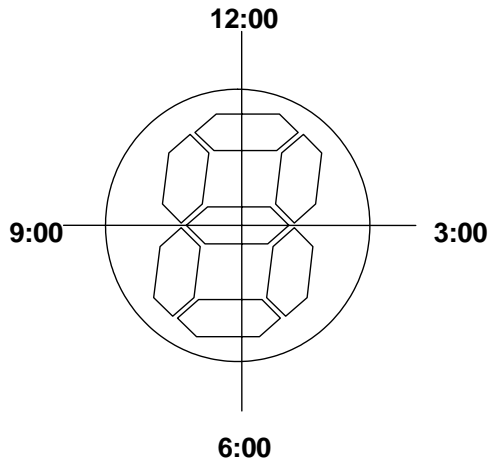

View Angle

### (3) Mechanical Units

#### 3.1 Mechanical Diagram

NO	Document Number	Attachment file
1	MF2432VP-AS1-101	

Double-Click the "Attachment Icon" above for opening attachment file.

## 3.2 Back-light Specification

### LED Backlight Styles:

The LED chips are distributed over the whole light area of the illumination unit, which gives the most uniform light.

### 3.2-1. Data About LED Backlight

PARAMETER	SYMBOL	MIN.	TYP.	MAX.	UNIT	TEST CONDITION	NOTE
Backlight Type	LED / WHITE						-
Supply Current	I <sub>LED</sub>	-	36	-	mA	V <sub>LED</sub> ≤ 3.5V	-
Reverse Voltage (Single chip)	V <sub>R</sub>	-	-	3.5	V	-	-
Luminous Intensity	I <sub>V</sub>	200	-	-	cd/m <sup>2</sup>	I <sub>LED</sub> = 36mA	-
Luminous Intensity Ratio	-	-	-	30	%	-	-

NOTE : 1. Average Luminous Intensity of P1 – P9

2. Luminous Intensity Ratio = (MAX-MIN)/ MAX.

### 3.2-2. Internal Circuit Diagram

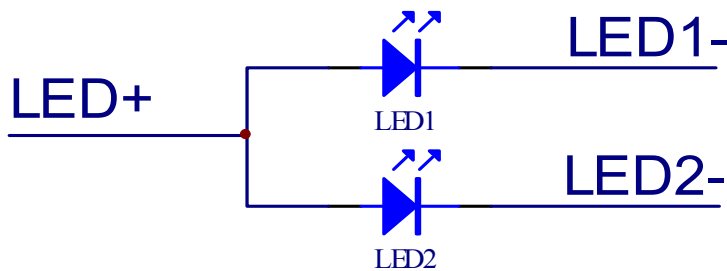

### 3.2-3. MEASURED METHOD (X\*Y: Light Area)

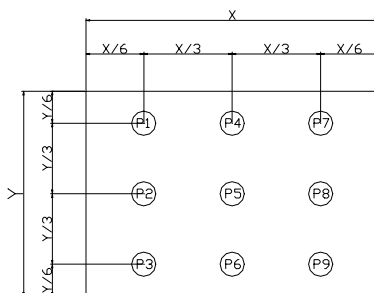

(Effective spatial Distribution)

Hole Diameter  $\phi$ 3mm; 1 to 9 per Position Measured Luminous Intensity Ratio

### 3.3 Packing Method

---

NO	Document Number	Attachment file
1	MF2432VP-M1-01	

Double-Click the "Attachment Icon" above for opening attachment file.

## (4) Quality Units

### 4.1 Specification of Quality Assurance

---

#### 4.1-1.Purpose

This standard for Quality Assurance should affirm the quality of LCD module products to supply to purchaser by WINTEK CORPORATION (Supplier).

#### 4.1-2.Standard for Quality Test

a. Inspection :

Before delivering, the supplier should take the following tests, and affirm the quality of product.

b. Electro-Optical Characteristics:

According to the individual specification to test the product.

c. Test of Appearance Characteristics:

According to the individual specification to test the product.

d. Test of Reliability Characteristics:

According to the definition of reliability on the specification for testing products.

e. Delivery Test:

Before delivering, the supplier should take the delivery test.

(i) Test method: According to **ANSI/ASQC Z1.4-2003.General Inspection Level take a single time.**

(ii) The defects classify of AQL as following:

Major defect: AQL=0.65

Minor defect: AQL=2.5

Total defects: AQL=2.5

#### 4.1-3.Nonconforming Analysis & Deal With Manners

a. Nonconforming analysis:

(i) Purchaser should supply the detail data of non-conforming sample and the non-suitable state.

(ii) After accepting the detail data from purchaser, the analysis of nonconforming should be finished in two weeks.

(iii) If supplier can not finish analysis on time, must announce purchaser before two weeks.

b. Disposition of nonconforming:

(i) If find any product defect of supplier during assembly time, supplier must change the good product for every defect after recognition.

(ii) Both supplier and customer should analyze the reason and discuss the disposition of nonconforming when the reason of nonconforming is not sure.

#### 4.1-4. Agreement items

Both sides should discuss together when the following problems happen.

- a. There is any problem of standard of quality assurance, and both sides think that it must be modified.
- b. There is any argument item which does not record in the standard of quality assurance.
- c. Any other special problem.

#### 4.1-5. Standard of The Product Appearance Test

a. Manner of appearance test:

- (i) The test must be under 20W x 2 or 40W fluorescent light, and the distance of view must be at 30 cm.
- (ii) When display on use front-light test, while display off use back-light test.
- (iii) The test direction is base on about around 45° of vertical line.

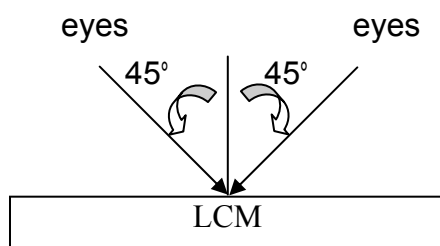

(iv) Definition of area:

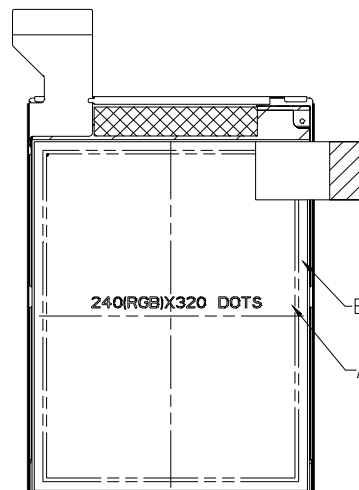

A Area : Viewing area.

B Area : Out of viewing area (Outside viewing area)

Any defect at area B could be ignored. If customer has particular requirement, this requirement should be clearly defined in inspection specification. If inspection specification has defined other criteria, the final judgement should follow the inspection specification .

b. Basic principle:

- (i) It will accord to the AQL when the standard can not be described.
- (ii) The sample of the lowest acceptable quality level must be discussed by both supplier and customer when any dispute happened.
- (iii) Must add new item on time when it is necessary.

c. Standard of inspection:( Unit: mm)

#### 4.1-6. Inspection specification

NO	Document Number	Attachment file
1	M1L070012	

Double-Click the "Attachment Icon" above for opening attachment file.

#### 4.2 Standard Specification for Reliability

NO	Document Number	Attachment file
1	M3ET090003	

Double-Click the "Attachment Icon" above for opening attachment file.

## 4.3 Precautions in Use of LCM

### 4.3-1 Handling of LCM

- Don't give external shock.
- Don't apply excessive force on the surface.
- Liquid in LCD is hazardous substance. Must not lick and swallow. when the liquid is attach to your hand, skin, cloth etc. Wash it out thoroughly and immediately.
- Don't operate it above the absolute maximum rating.
- Don't disassemble the LCM.

### 4.3-2 Storage

- Store in an ambient temperature of 5 to 45 , and in a relative humidity of 40% to 60%. Don't expose to sunlight or fluorescent light.
- Storage in a clean environment, free from dust, active gas, and solvent.
- Store in anti-static electricity container.
- Store without any physical load.

### 4.3-3 Soldering

- Use the Sn-Ag-Cu (96.5, 3.0, 0.5) solder
- Iron : Temperature 300 and less than 5-6 sec during soldering.
- Rewiring : no more than 3 times.

### 4.3-4 Assembly

- The front polarizer is covered with a protective foil which should be removed before use.

## (5) Substance Management Units

### 5.1 Product Substances Management Documentation

NO	Document Number	Attachment file
1	Environment management standard(EMS-P-017-01)	

Double-Click the "Attachment Icon" above for opening attachment file.